

# Crosby®



**2016**  
METRIC



CROSBY® McKISSICK® LEBUS® NATIONAL® CROSBYIP® CROSBY CLAMP-CO®

With Product Warning & Application Information



# Table of Contents

<b>GLOSSARY</b> (Important terms and definitions) .....	2
<b>QUALITY CONTINUUM</b> (What it takes to be Crosby or Equal, Product Bulletins) .....	11
<b>WIRE ROPE END TERMINATIONS</b> (Clips, Sockets, Swage Fittings, Wirelock®) .....	31
<b>SHACKLES</b> (Anchor, Chain, Bolt-Type, Screw Pin, Round Pin, Wide Body) .....	73
<b>SLING SAVER FITTINGS</b> (Shackles, Hooks & Accessories specifically for Web & Round Slings) .....	95
<b>HOOKS &amp; SWIVELS</b> (Hooks, Latches, Swivels) .....	109
<b>RIGGING ACCESSORIES</b> (Thimbles, Links, Rings, Eyebolts, Turnbuckles) .....	155
<b>CHAIN &amp; ACCESSORIES</b> (Chain, Grade 80 and 100 Fittings, Alloy Fittings, Loadbinders) .....	217
<b>SHEAVES</b> (McKissick and Western) .....	277
<b>MCKISSICK BLOCKS</b> (Construction Blocks, Crane Blocks, Overhaul Balls, Snatch Blocks, Oilfield Blocks) .....	305
<b>WESTERN AND MARINE BLOCKS</b> (Wood Blocks, Steel Blocks, Snatch Blocks, Construction Blocks) .....	393
<b>CROSBYIP PLATE CLAMPS / CLAMP CO CLAMPS</b> (Vertical, Horizontal, Beam, Drum and Special Lifting Clamps) .....	409
<b>CROSBY TRAWLEX® AND ACCESSORIES</b> .....	437
<b>CROSBY KUPLEX® SYSTEMS</b> .....	447
<b>SPECIAL PRODUCTS</b> (Special Engineered Product Forms) .....	471
<b>RIGGING INFORMATION</b> (Basic sling angle information, Inspection and Replacement Guidelines per ASME B30.9) .....	491
<b>ALPHABETICAL INDEX</b> .....	501
<b>NUMERICAL INDEX</b> .....	504



## CORPORATE OFFICE

2801 Dawson Rd., Tulsa, OK 74110 • P: 918.834.4611 • F: 918.832.0940  
www.thecrosbygroup.com

## United States Facilities

### Crosby-Tulsa

2857 Dawson Rd.  
Tulsa, OK 74110-5042

### Crosby-Longview

900 Fisher Rd.  
Longview, TX 75604-4709

### Crosby-Little Rock

2511 W. Main Street  
Jacksonville, AR 72076-4213

### Crosby-Dallas

2101 Exchange Dr.  
Arlington, TX 76011-7823

## Canada Facility

### Crosby-Brampton

145 Heart Lake Rd.  
Brampton, Ontario,  
Canada L6W 3K3  
P: (905) 451-9261  
F: (877) 260-5106



Scan this QR code with  
your smart device to  
view our corporate video.



## Europe Facilities

### Crosby-Heist-op-den-Berg

Industriepark Zone b N°26  
2220 Heist-op-den-Berg  
P: (+32) (0)15 75 71 25  
F: (+32) (0)15 75 37 64

### Crosby-Cergy

21, rue du Petit Albi  
Parc d'Affaires Silic  
95800 Cergy - St. Christophe  
P: (+33) (0)1 34 201 180  
F: (+33) (0)1 34 201 188

### Crosby-Ede

Celsiusstraat 51  
P.O. Box 518  
6710 BM Ede  
P: (+31) (0)318 690 999  
F: (+31) (0)318 690 933

### Crosby-West Midlands

Station Street  
Cradley Heath  
West Midlands B64 6AJ  
P: (+44) (0)1226 290 516  
F: (+44) (0)1226 240 118



# General Information



## GENERAL CAUTIONS AND WARNINGS

All products manufactured by The Crosby Group LLC, are sold with the express understanding that the purchaser is thoroughly familiar with the safe and proper use and application of the product.

Responsibility for the use and application of the products rests with the user. The Crosby Group disseminates products warnings and end user application information through various channels. In addition, Crosby provides formal product training seminars and our engineering personnel are readily available to answer your technical questions. For more information read the Crosby General Catalog, refer to Crosby's web-site at [www.thecrosbygroup.com](http://www.thecrosbygroup.com), or contact your Crosby distributor or Crosby direct at 918-834-4611.

Failure of the product can occur due to misapplication, abuse, or improper maintenance. Product failure could allow the load to become out of control, resulting in possible property damage, personal injury or death.

There are numerous government and industry standards that cover products made by Crosby. This catalog makes no attempt to reference all of them. We do reference the standards that are most frequently asked about.

Ratings shown in Crosby Group literature are applicable only to new or in "as new" condition products.

Load Limit ratings indicate the greatest force or load a product can carry under usual environmental conditions. Shock loading and extraordinary conditions must be taken into account when selecting products for use in a system.

In general, the products displayed in Crosby Group literature are used as parts of a system being employed to accomplish a task. Therefore, we can only recommend within the Working Load Limits, or other stated limitations, the use of products for this purpose.

The Working Load Limit, or Design Factor, or Efficiency Rating of each Crosby product may be affected by wear, misuse, overloading, corrosion, deformation, intentional alteration, and other use conditions. Regular inspection must be conducted to determine whether use can be continued at the catalog assigned WLL, a reduced WLL, or whether the product must be withdrawn from service.

Crosby Group products generally are intended for tension or pull. Side loading must be avoided, as it exerts additional force or loading which the product is not designed to accommodate.

Welding Crosby load support parts or products can be hazardous. Knowledge of materials, heat treatment, and welding procedures are necessary for proper welding. Crosby Group should be consulted for information.

The assigned Ultimate Load Rating of Crosby Group products for the reeving of wire, manila, or synthetic rope is based upon design; the catalog ultimate strength for the rope parts, when totaled, may exceed the assigned Ultimate Load Rating.

The Working Load Limit of a sling must not exceed the lowest Working Load Limit of the components in the system.

The recommended Proof Load on all items in this catalog is 2 times the Working Load Limit unless otherwise shown.

Products that Crosby intends for swaging are identified in this catalog. For proper swaging machine training, operations and die selection, refer to specific product section in this manual. To develop other product for swaging requires knowledge of materials, heat treatment, product design, die design and performance of the final product.

Use only new genuine Crosby parts as replacements when servicing or repairing Crosby products.

Crosby products are to be considered as sparking, unless otherwise noted.

Product Label Replacement - In accordance with ANSI535.4-1991, "Product Safety Labels" should be periodically inspected and cleaned. "Product Safety Labels" should be replaced when they are no longer legible. Current Crosby warning and application labels, for applicable products, are available from The Crosby Group LLC.

Two decimal and fractional dimensions shown in catalog are intended as nominal dimensions only. If three decimal dimensions are shown, contact Crosby for tolerance information.

*Specific warning and application instructions are included in this catalog. The instructions can be found at the end of each product section. The symbol shown to the right can be found on the page for products that have application instructions included in this catalog. The page numbers that the specific product information can be found are shown in the box for easy reference.*



## LOW TEMPERATURE SERVICE

Crosby forged and cast steel products can be used in general service conditions down to temperatures of -40° F (-40° C). McKissick blocks can be used in general service conditions down to temperatures of -4° F (-20° C). At temperatures from 0° F to -40° F (-18° C to -40° C), good rigging practice requires special attention in the following areas.

1. Lifting should be performed at a steady rate. Shock loading should be avoided.
2. Equipment containing bearings should have increased inspection and maintenance schedule, and may require special lubrication.
3. All lifting equipment should be given a thorough visual inspection before each lift.
4. Remove nicks, gouges, or cracks by grinding (5% maximum material removal).
5. Do not use fittings that have been welded or modified after leaving the factory.
6. If determined to be necessary by the user, lifting equipment should undergo periodic inspection by dye penetrant or magnetic particle surface inspection.

For operation at temperatures below -40° F (-40° C), consider "Cold Tuff" products or contact Crosby Engineering.

## ELEVATED TEMPERATURE SERVICE

Crosby forged and cast steel products can be used in general service conditions up to temperatures of 400° F (204° C). The following should be considered when operating up to temperatures of 400° F (204° C).

1. Products that contain non-ferrous materials, and lubricants, plastics, etc. may be adversely affected by high temperatures, and typically should not exceed 200° F (93° C).
2. Galvanized, plated or painted fittings may suffer some or total degradation of the surface finish.
3. Extended exposure to elevated temperatures can cause severe surface scaling and significant permanent reduction of properties.
4. Repeated heating and cooling to room temperatures can result in temper embrittlement.

For other operating temperatures or products, contact Crosby Engineering.



## DEFINITIONS

**STATIC LOAD** - The load resulting from a constant applied force or load.

**WORKING LOAD LIMIT** - The maximum mass or force which the product is authorized to support in general service when the pull is applied in-line, unless noted otherwise, with respect to the centerline of the product. This term is used interchangeably with the following terms: WLL, Rated Load Value, Resultant Working Load.

**WORKING LOAD** - The maximum mass or force which the product is authorized to support in a particular service.

**PROOF LOAD** - The average force applied in the performance of a proof test; the average force to which a product may be subjected before deformation occurs.

**PROOF TEST** - A test applied to a product solely to determine injurious material or manufacturing defects.

**ULTIMATE LOAD** - The average load or force at which the product fails or no longer supports the load. Interchangeable with Ultimate Strength.

**SHOCK LOAD** - A force that results from the rapid application of a force (such as impacting or jerking) or rapid movement of a static load. A shock load significantly adds to the static load.

**DESIGN FACTOR** - An industry term denoting a product's theoretical reserve capability; usually computed by dividing the catalog ultimate load by the Working Load Limit. Generally expressed as a ratio, e.g., 5 to 1.

**COMMERCIAL SURFACE QUALITY** - The surface condition of the products shown in this catalog. The surface condition associated with the normal methods of production of raw material and machined surfaces. More refined surface qualities are considered as special.

**FATIGUE RATED** - Tested to a minimum standard of 20,000 cycles at 1.5 times the Working Load Limit. Will meet the requirements of the Euronorm standards for fatigue.

**ADJUSTED WORKING LOAD LIMIT** - The reduced maximum mass or force which the product is authorized to support for specific non-standard loading applications.

**Ton (T)** - North American unit of measure, equals 2,000 pounds. Also referred to as a short ton. Abbreviated by capital T.

**Tonne (t)** - Metric unit of measure, equals 1,000 kg. Abbreviated by lower case t.

## LIMITED WARRANTY

Purchaser and Crosby expressly agree that Crosby's warranty with respect to sale of its products is LIMITED solely to Crosby's choice of repair, replacement or refund of the purchase price of any product or part thereof determined by Crosby to be defective within the first 12 months following the transfer of title of the product from Crosby to the purchaser. Purchaser and Crosby expressly agree that upon termination of the aforementioned 12 month period, the purchased product carries no warranty whatsoever. Purchaser and Crosby expressly agree that the remedies provided in this section are the purchaser's exclusive remedies in connection with the purchase or use of the product. Purchaser and Crosby expressly agree that in no event shall Crosby be liable for any incidental or consequential damages in connection with the purchase or use of the product.

ALL OTHER WARRANTIES, INCLUDING EXPRESS WARRANTIES AND THE IMPLIED WARRANTIES OF MERCHANTABILITY AND FITNESS FOR A PARTICULAR PURPOSE ARE HEREBY DISCLAIMED. PURCHASER HEREBY WAIVES ALL OTHER WARRANTIES, RIGHTS AND REMEDIES ARISING BY LAW OR OTHERWISE INCLUDING, BUT NOT LIMITED TO, EXPRESS WARRANTIES, THE IMPLIED WARRANTY OF MERCHANTABILITY, ANY IMPLIED WARRANTIES ARISING FROM COURSE OF PERFORMANCE, COURSE OF DEALING OR USAGE OF TRADE, AND IMPLIED WARRANTY OF FITNESS FOR A PARTICULAR PURPOSE. ADDITIONALLY, CROSBY HEREBY DISCLAIMS ANY OF ITS OBLIGATIONS OR LIABILITIES ARISING FROM STATUTE, WARRANTY, CONTRACT, TORT OR NEGLIGENCE.

Complete Agreement: This Warranty between purchaser and Crosby is complete. All prior or contemporaneous discussions, representations and/or understanding are merged into this Warranty. All prior or contemporaneous agreements between the parties are superseded by this Warranty.

Choice of Law: Any dispute about the interpretation of this Warranty shall be governed by the laws of the State of Oklahoma.

Resolution of Disputes: Purchaser and Crosby expressly agree that any dispute arising out of the purchase, use or operation of the purchased product shall, upon written notice to the other party, be resolved through binding arbitration. The arbitration shall be governed by the then existing rules of the American Arbitration Association. The location of any arbitration shall be Tulsa, Oklahoma. The substantive laws of the State of Oklahoma shall govern the arbitration to the extent they are not in conflict with the then existing rules of the American Arbitration Association. In no event shall Crosby be liable for incidental or consequential damages as part of the arbitration award. The award, decision, or filing rendered by the arbitration shall be final, and judgment may be entered upon it in accordance with the applicable law in any court having appropriate jurisdiction.











# Explanation of Symbols



C - Carbon, A - Alloy, B - Bronze, SS - Stainless Steel, S or SC - Self Colored, Painted or Oiled, G - Coated for corrosion protection; may include Hot Dip galvanizing, electrolytic depositing, dimetcoated, impact galvanizing, spraying, etc.

All ratings given in tons refer to short tons of 2,000 lbs. Ratings given in metric tons equal 2,204 lbs., and are mentioned as “tonnes” (t) or “metric tons”.

Hot Dip galvanized Crosby products meet or exceed ASME 153 requirements.

SYMBOL	EXPLANATION OF SYMBOLS
	<p><b>QUIC-CHECK®</b> is a patented concept developed by Crosby's Research and Development Department which represents Crosby's ongoing commitment to Quality. <b>QUIC-CHECK®</b> incorporates the strategic placement of marking indicators on traditional rigging products to indicate reference points designed to enhance the safe and proper use of Crosby products.</p>
	<p><b>Load Rated®</b> is a registered Crosby trademark that identifies products that have the Working Load Limit indicated or affixed to it.</p>
	<p><b>Fatigue Rated®</b> is a registered Crosby trademark that identifies products that have proven to provide improved fatigue life (fatigue resistance) in actual use.</p>
	<p><b>Quenched and Tempered®</b> is a registered Crosby trademark identifying product that is heat treated utilizing Crosby's perfected quench and tempering methods.</p>
	<p><b>MAXTOUGH®</b> is a registered Crosby trademark identifying products that are statistically verified to meet or exceed impact values of 31 ft-lbs. at -4° F (42 Joules at -20° C) based on a high level of confidence. The confidence level is an index of certainty. MAXTOUGH is another Value-Added benefit of The Crosby Group.</p>
	<p><b>Type Approved</b> is a symbol that identifies products that have been Type Approved by various third party organization Meeting a standard can be declared as a result of “<b>TYPE APPROVAL</b>” by a third party organization. Type Approval requires:</p> <ol style="list-style-type: none"> <li>(1) A <b>TYPE APPROVAL CERTIFICATE</b> that verifies that the product design complies with the referenced standard(s) and,</li> <li>(2) A <b>(MSA) MANUFACTURING SURVEY</b> that verifies that the manufacturing location has been verified as capable of making the product.</li> <li>(3) A <b>PRODUCT CERTIFICATE</b> must be made available that verifies that the product shipped meets the requirements of the <b>TYPE APPROVAL</b> and <b>MSA</b>. This product certificate must reference a serial number or P.I.C. and is issued for each product produced.</li> </ol>
	<p>Products containing this logo are <b>RFID Equipped</b> and are designed to be used with the Crosby <b>QUIC-CHECK®</b> Inspection and Identification System (U.S. Patent 7,825,770).</p>
	<p><b>Crosby Certpro®</b> is a web-based system that Crosby or an Authorized Distributor can create a certified product certificate for genuine Crosby products. Product performance is key to lifting applications and proper certification of critical lifting products is often required. Certpro supports the following basic certifications:</p> <ol style="list-style-type: none"> <li>(1) Standard C of C: Self declaration that the product is in conformance with the specifications and provisions set forth in Crosby literature current at the time of manufacture.</li> <li>(2) Material Certificates: Available for non-block products as a complement to standard C of C as well as other certifications, PIC is required.</li> <li>(3) Data Books: Available for selected products to support third party certification and other special testing requirements.</li> </ol>
	<p><b>Crosby Verification Pro®</b> is a web based system available on the Crosby website that allows customers to confirm that the certificate you hold in your hand matches the product information in the Crosby database. Verification Pro provides a second layer of confidence that the product supplied with the certificate is indeed a genuine Crosby product.</p>









The Crosby Group reserves the right to change product design, materials, and specifications without incurring obligations. Reference to standards or specifications in Crosby literature is only intended to show a general compliance and must not be interpreted as meeting all terms of a contract or purchase order.



# Type Approved Products

Several Crosby products have been Type approved by various third party organizations. Meeting a standard can be declared as a result of "TYPE APPROVAL" by a third party organization. Type approval requires:

1. A **TYPE APPROVAL CERTIFICATE** that verifies that the product design complies with the referenced standard(s), and
2. A **(MSA) MANUFACTURING SURVEY** that verifies that the manufacturing location has been verified as capable of making the product, and
3. A **PRODUCT CERTIFICATE** must be made available that verifies that the product shipped meets the requirements of the TYPE APPROVAL and MSA. This product certificate must reference a serial number or P.I.C. and is issued for each product produced.













ABS / DNV LOCATOR	MANUFACTURING SURVEY (MSA)	TYPE APPROVAL CERTIFICATE	PRODUCT CERTIFICATE
<p align="center"><b>ABS HOOKS</b>  <b>TA# 6HS168754A</b>                      Certificate Included with Standard 319, 320 and 322 hooks on pages 110 - 116.</p>			
<p align="center"><b>ABS SHACKLES</b>  <b>TA# 6HS168754B</b>                      Certificate Included with Standard 209, 210, 2130, 2140 and 2150 Shackles on pages 77 - 82.</p>			
<p align="center"><b>ABS M-491 BLOCKS</b>  <b>TA# 15VC1318082</b>                      Certificate is available with all Standard M-491 blocks shown on page 371.</p>			

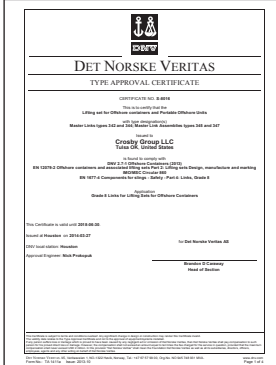



ABS / DNV LOCATOR	MANUFACTURING SURVEY (MSA)	TYPE APPROVAL CERTIFICATE	PRODUCT CERTIFICATE
<p><b>DNV CT SHACKLES TA# S-8378</b></p> <p>Certificate is available with 2130CT and 2140CT shackles shown on page 88.</p>			
<p><b>DNV CT MASTER LINKS TA# S-8355</b></p> <p>Certificate is available with A-342CT and A-345CT links shown on page 160-161.</p>			
<p><b>DNV SOCKETS 517 M-Line Type TA# S-5558</b></p> <p>DNV Sockets are special order sockets that must have the certificate requested upon order.</p>			
<p><b>DNV CT SIDE PULL HOIST RINGS TA# D-4121</b></p> <p>DNV Side Pull Hoist Rings are special order hoist rings that must have the certificate requested upon order.</p>			

**CROSBY® QUALITY CONTINUUM**

<p><b>ABS / DNV LOCATOR</b></p>	<p><b>MANUFACTURING SURVEY (MSA)</b></p>	<p><b>TYPE APPROVAL CERTIFICATE</b></p>	<p><b>PRODUCT CERTIFICATE</b></p>
<p><b>DNV OC MASTER LINKS TA# S-0001V</b></p> <p>Certificate is available with all standard A-344 and A-347 links shown on pages 162 - 163.</p>			
<p><b>DNV OC MASTER LINKS TA# S-8016</b></p> <p>Certificate is available with all standard A-342 and A-345 sizes 1 1/4" through 2" links shown on pages 160 - 161.</p>			
<p><b>DNV OC SHACKLES TA# S-8357</b></p> <p>Certificate is available for standard 2t through 25t 209 and 2130 shackles shown on pages 77 - 79.</p>			
<p><b>DNV 2160 SHACKLES TA# D-4310</b></p> <p>Certificate and full test data book provided with standard 2160 shackles 18t through 1550t on pages 84 - 85.</p>			

The Crosby Group reserves the right to change product design, materials, and specifications without incurring obligations. Reference to standards or specifications in Crosby literature is only intended to show a general compliance and must not be interpreted as meeting all terms of a contract or purchase order.





In a world where things are not always what they seem... **how can you ensure genuine Crosby products are being used on the job site?**

A Simple Three Step Process Helps to Ensure You are Always Supplied Genuine Crosby Product.

**STEP 1** Purchase your Crosby product only through authorized Crosby distributors. Crosby's large network of authorized distributors are poised to provide you the many value added services available from Crosby.

**STEP 2** When purchasing Crosby products, always require an authentic Certificate of Conformance (including the item's (PIC) Product Identification Code) generated from Crosby's "On-Line" certificate retrieval system; available 24/7 only from your local authorized Crosby dealer. CertPro® certificates provide you the assurance that you are receiving authentic Crosby products. A variety of certificate types are available through CertPro®. Examples include: Certificates of Conformance, Material Certificates and Type Approval Certificates.



**STEP 3** If there are any questions about the authenticity of your Crosby CertPro® certificates, they can be verified through CrosbyVerificationPro®, our new "On-Line" certificate system. Through Crosby VerificationPro®, YOU can verify the certificate's authenticity by simply entering information from the supplied certificate (the certificate number, the stock number, the Product Identification Code (PIC) and the name of the authorized Crosby dealer) onto the user friendly screen, located at our website shown below.

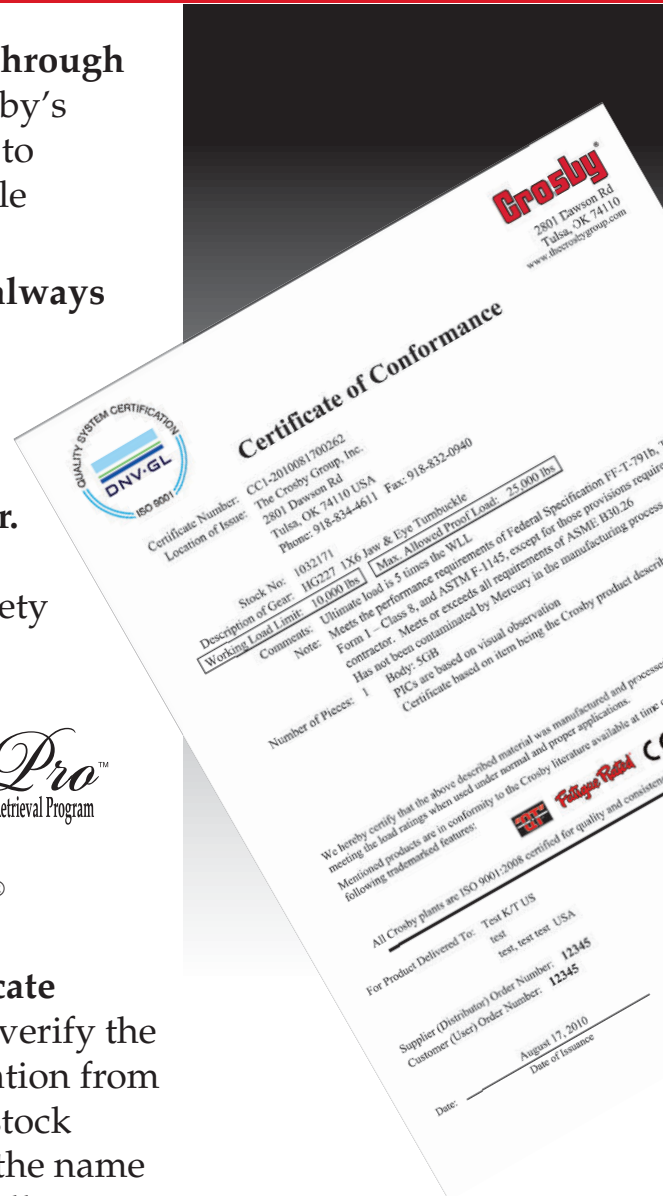

*The Market Leader Yesterday, Today and Tomorrow*



# QUIC-CHECK V4™ Inspection and Identification System

www.thecrosbygroup.com



## AN EXPERT INSPECTION SYSTEM BUILT BY EXPERTS IN THE INDUSTRY

The New Crosby QUIC-CHECK® Version 4 Inspection and Identification System

**Crosby QUIC-CHECK® V4 is a better “user friendly” way to do inspections.**

The Crosby QUIC-CHECK® V4 Inspection and Identification System has been designed to provide a more accurate and efficient system for inspecting slings and various RFID equipped products. This is accomplished by combining an electronic proprietary inspection software program developed by Crosby with RFID (Radio Frequency Identification) technology. In addition to collecting and recording the inspection information, Crosby QUIC-CHECK® V4 can also provide a quick view of historical information on previous inspections from any referenced product.

### The Process is Simple, Efficient, and Accurate

1. Create the product or sling in QUIC-CHECK® V4 using your smart phone or the web browser on your PC.
2. Scan the product's RFID tag to associate it with the product created in Step 1. (This information is automatically sent to a secure cloud database, where it's immediately available on all your devices.)
3. Utilizing your smart phone or tablet, conduct the inspection of the item and any others that might be due. Your results are pushed immediately to the cloud database.
4. Use the web browser on your PC to create your inspection report.

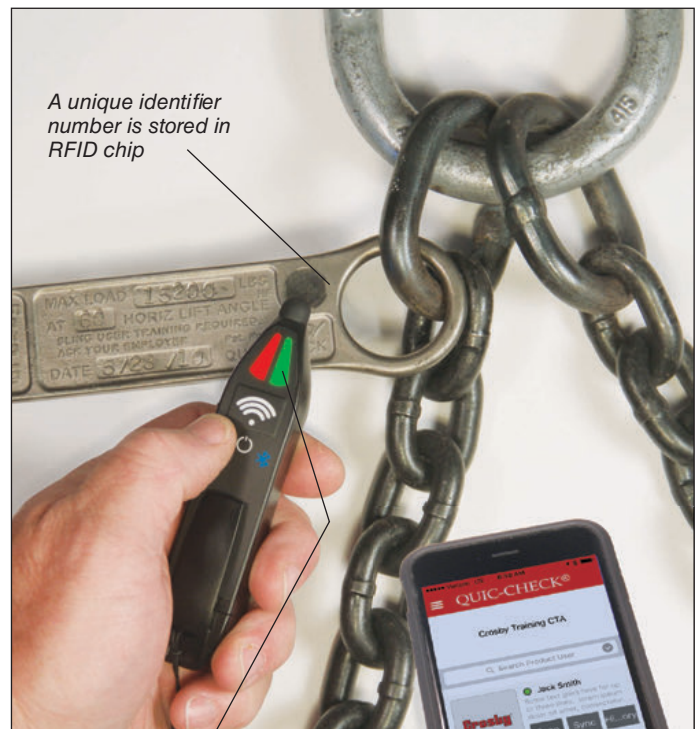

*A unique identifier number is stored in RFID chip*

*Scan tag to match product information with unique identifier number*

*Inspection and ID information is sent to cloud via secure network connections*



# IT TOOK LIFTING INDUSTRY KNOW-HOW TO CREATE A “WORLD CLASS” INSPECTION AND ID SYSTEM

## Crosby QUIC-CHECK® V4 and ASME B30.9

ASME B30.9 requires every sling to be inspected, at a minimum, once a year. The spec also requires the user to have a written inspection report on file for the most recent inspection. Using conventional inspection methods, the complete process from inspection to the final printed report can be very labor intensive, sometimes taking days or even weeks. Using Crosby QUIC-CHECK® V4, the time can be dramatically reduced by eliminating manual pen and paper data entry. The inspector easily records the condition of the product in accordance with the ASME specification in a dramatically shorter time.

In addition to providing you a faster, more accurate way of doing inspections, Crosby QUIC-CHECK® V4 provides two major advantages over conventional inspection methods:

- The system provides a more streamlined approach to inspection while reducing the total time associated with the current process.
- It allows for a reduction in the manpower required when performing the inspection, while also providing quicker inspection reports with a higher level of security and accuracy.

## Utilizing innovation to provide a streamlined and automated approach to the inspection process.

- QUIC-CHECK® V4 is a complete rewrite of the previous application and utilizes “state of the art” programming interfaces and tools. (You’ll be amazed at the speed!)
- Using your smart phone, QUIC-CHECK® V4 supports both iOS™ and Android™ phone/tablets as your mobile device; there is no expensive, proprietary handheld unit required.

- RFID tag scans are accomplished with a small Bluetooth scanner that connects wirelessly to your mobile device.
- Your data is uploaded immediately to our secure cloud server, where it is available on any of your other devices. (If no connectivity is available, the data is stored temporarily on your device until connectivity is established).

## The Crosby QUIC-CHECK® V4 Inspection and ID System Benefits

- Reduces total inspection process time up to 65%.
- Reduces cost of overall inspection process.
- Enhanced data accuracy
  - Eliminates errors inherent in current process.
  - No more handwritten inspection reports.
  - No more manual typing of inspection reports.
- Provides inspection reports quicker, with a higher level of accuracy.
- Ability to keep electronic records of slings produced/inspected.
  - Use your mobile device’s camera to record any anomalies noted during the inspection.
- Ability to quickly reference support materials designed to facilitate the inspection process.
- Maintains an electronic file for each sling and various Crosby hardware supplied to an end user - from sling inception through the last day it is in service.

## RFID-Equipped Crosby® Products

Many standard Crosby® products come from the factory equipped with RFID chips that you can program and utilize in your inspection efforts.



Crosby® Eliminator™



Crosby® Red-Pin® Shackles



Crosby® Hoist Rings



McKissick® Blocks



CrosbyIP® Lifting Clamps



Crosby Clamp-Co® Lifting Clamps





**HR1000MCT "Cold TUFF" Hoist Ring..... 179**

Choose the new metric HR1000MCT for versatile and dependable material handling in extreme conditions such as subsea and other saltwater environments. Like our standard heavy lift hoist rings, the forged bail provides greater durability in potentially abusive environments.



**Crosby SL150 Slide-Loc Lifting Point..... 187**

The new Crosby SL-150 Slide-Loc lifting point is an innovative alternative to eye bolts. At the center of the new design is a patent pending locking mechanism, making the lifting point well suited for quick attachment to the load surface, and a bail that swivels 360 degrees to assist with proper alignment of sling...all without the need for tools.



**Crosby IPU10A Automatic Vertical Clamp ..... 413**

Features of the new IPU10A "automatic closing" models allow the user to properly attach the clamp to the top edge of steel in hard to reach applications, eliminating the need for ladders or other potentially unsafe devices.







#### **THE QUALITY CONTINUUM**

A symbol identifying six segments of Crosby's business that when viewed as one, differentiates Crosby in the market place.

The six qualities are:

*Customer Service*  
*Research & Development*  
*Engineering*  
*Manufacturing*  
*Complete Product Line*  
*Risk Management*

#### **CROSBY COMMUNICATION SYSTEM**

##### **PURPOSE**

The Crosby Communication System has been developed to convey the positive aspects, or Value Added features of the Quality Continuum to the marketplace.

##### **RESOURCES**

The resources of the Crosby Communication System which are utilized to implement the program include:

*Trained Crosby Personnel*  
*Video Training Program*  
*Modular Training Presentations*  
*Crosby Literature*  
*Product Bulletins*  
*Warnings and Application Information*

The individual Product Bulletins, which address and identify many of the key elements that differentiate Crosby in the marketplace, are included in this section for your information.

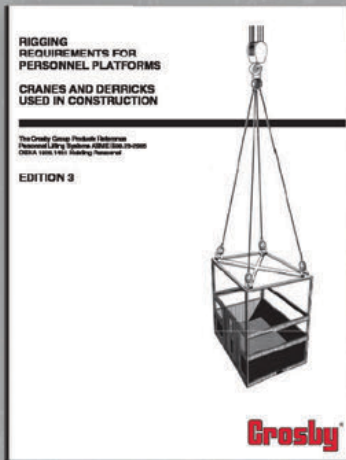

### Personnel Platform

This brochure translates the rigging requirements established by OSHA concerning lifting personnel into various types of components that could be used to comply with the intent of the regulation.

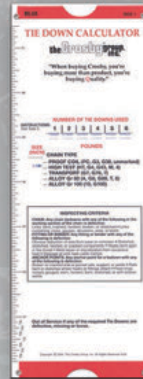

### Tie Down Calculator

This chart contains detail on various tie down related areas such as determining how many tie downs are required depending on what type of systems are used, determining the minimum number of tie downs that you must have to remain in service, and detailed inspection criteria. The information in the chart is adapted from the CVSA Cargo Securement Tie Down Guidelines, November 2003.

**Contact Your Local Authorized Crosby Distributor or Our Customer Service Department for more information.**



### General Catalog on Flash Drive

The same comprehensive information as our General Catalog. Only a mouse click away.

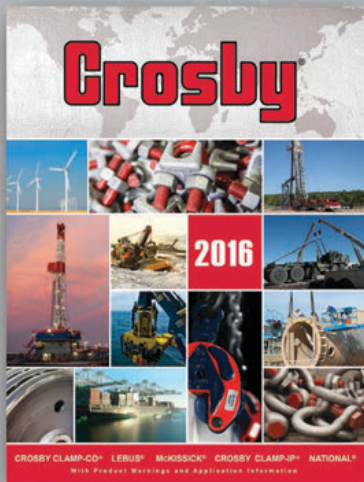

### General Catalog

Our most comprehensive piece of literature. The Crosby general catalog contains detailed engineering specifications, definitions, illustrations, and drawings, as well as application instruction and warning information on selected items to assist in selecting the proper equipment for the job.

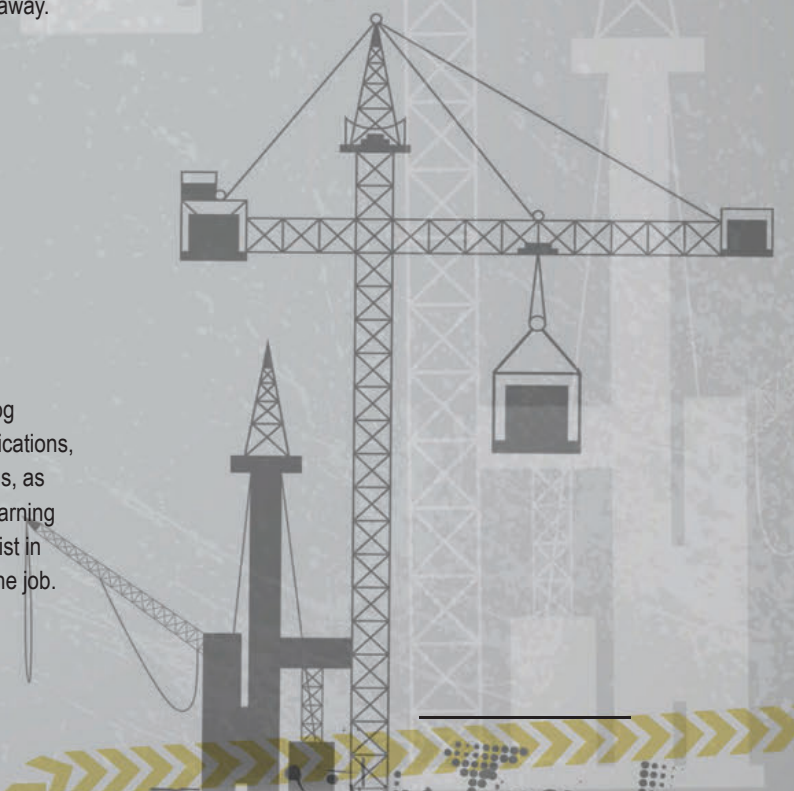





## Crosby Website Features...

### ONLINE CATALOG

Check out the latest in Multi Language catalogs:

- English
- Portuguese
- Spanish
- Russian
- German
- Chinese
- Italian
- Korean
- French

### PRODUCT INFORMATION

Our online catalog also features information on...

- New Products
- Product
  - Drawings
  - Authenticity
  - Warnings
- MSDS Sheets

### TRAINING INFORMATION

We offer Training for our products.

- Seminar Schedule
- Request on-site Training
- Order training material
- Rigging aptitude test

### SALES REP LOCATOR

Find knowledgeable sales representatives near you.

### BUSINESS PARTNER CENTRAL

Log on to our specialized distributor services.

## Crosby Training Seminars

Distributor sponsored seminars are scheduled throughout the world, or can be held on-site at your location.



### CROSBY LITERATURE

Your best training material and selling tools. These product specific brochures contain important information on rigging requirements, product application and warning instructions plus engineering specifications, definitions, illustrations, photos and drawings.



### CROSBY REFERENCE MATERIAL

**Tie Down Calculator** - contains details on various tie downs required for your type of system. Detailed inspection criteria adapted from the CVSA Cargo Securement Tie Down Guidelines.

**National Die Guide** - assists you in selecting the proper die to meet your swaging needs. The chart shows the correct stock number to use when ordering dies.

**Lifting Guide** - pocket size, laminated folding card with information on rigging, inspection, capacities and design factor. Each card is packed with information on sling angle, load distribution and hardware.



### CROSBY TRAINING WORKBOOKS

Crosby Seminar Workbooks provide an excellent source for product and application information, with many references to applicable standards. These workbooks are the same books used in our training seminars.



Scan this QR code with your smart device to view the full list of our training materials.



The Market Leader: Yesterday Today and Tomorrow



When you read on a contract the statement **"Crosby or Equal,"** you owe it to yourself and the personnel that will be using the product to understand that there is no equal to Crosby. The following information has been designed to help you determine the many "Value Added" features of Crosby products that are the foundation for the performance characteristics and technical support required from a quality manufacturer. You will see from the following information that **"When buying Crosby, you're buying more than product, you're buying Quality."**

### Engineering Excellence

The majority of Crosby's products are "Heat Treated". The "Heat Treatment" allows the product to deform if overloading occurs, giving warning before ultimate failure. An "As-Forged," or non-heat treated product, will break with little or no warning. This is called a "Catastrophic Failure," and is a result of brittleness or lack of toughness in the non-heat treated product as compared to the "Heat Treated" product.

### Quality Control

The majority of the steel purchased by Crosby is isolated from production until approved by our metallurgical lab. Each product is individually "PIC Coded" (Product Identification Code) to allow traceability to its respective date of production and material certification.

### Durability

Competitors' products cannot be substituted in place of Crosby's just because they look alike. Crosby products are manufactured with the highest design factors in the industry. Crosby's products are better able to withstand abusive field conditions because of the improved impact and fatigue characteristics designed into each item of our line. Crosby recognizes the importance of all four of these essential properties in its products: *Working Load Limit, Ductility, Fatigue and Toughness.*

### Recognized Dependability

Crosby is considered the standard of the industry, both nationally and internationally. This can be drawn from the fact that most contracts involving rigging products, in the U.S. and around the world, read "Crosby Only" or "Crosby or Equal."

### Industry Education

Crosby has always been concerned that our users are knowledgeable with the installation, use, inspection, and maintenance of our products. Crosby offers a formal product instruction and warning program which includes such "Value Added" features as instruction sheets attached to individual items, comprehensive literature, and a video training program. A Technical Support Team is also ready to answer any questions in regard to our products or services. This instruction can be provided through training seminars and on-site engineering applications. These services provide important benefits, such as accident prevention which results in lower costs of doing business for our customers.

### Customer Service

The phrase Customer Service at Crosby means more than just having the product available when you need it. Customer Service also means having a full time, knowledgeable District Sales Representative available to serve you. It also means having a well trained and fully equipped Customer Service Department, a broad product line offering, 3200 Authorized Crosby distributors worldwide, and a Technical Support Team second to none. Finally, Customer Service means having a management team dedicated to ensure the previously mentioned services run smoothly so that your needs are met.

IF YOU NEED MORE INFORMATION ABOUT THESE VALUE ADDED BENEFITS, PLEASE CONSULT YOUR SAFETY AND RIGGING DEPARTMENT, YOUR LOCAL CROSBY DISTRIBUTOR, OR A CROSBY REPRESENTATIVE BEFORE MAKING YOUR DECISION!

**Remember: "When buying Crosby, you're buying more than product, you're buying Quality."**

Crosby's Quality Continuum is a Symbol Identifying Six Segments of Our Business that, when Viewed as One, Differentiates Us in the Marketplace.

THE QUALITY CONTINUUM	THE VALUE ADDED FEATURES
<p><b>1 MANUFACTURING</b></p> <p>Manufacturing is the process of turning a raw material into a finished product. When it comes to manufacturing, The Crosby Group has extensive and unique capabilities that equip it with the tools needed to provide the quality and type of fittings and blocks needed by our customers. Modern facilities and up-to-date processes support the manufacturing of our products within Crosby, by Crosby employees. Our Product Identification Code traces the manufacturing process from raw material to production, helping to insure that the proper controls are maintained.</p>	<ul style="list-style-type: none"> <li>• Modern facilities and state-of-the-art processes that support the manufacture of our products.</li> <li>• Extensive and unique capabilities that equip us with the tools needed to provide the quality and type of fittings and blocks needed by you, the customer.</li> <li>• Traceability of each product through the manufacturing process (from raw material to production) with our Product Identification Code (P.I.C.) System which helps to insure that the proper controls are maintained.</li> </ul>
<p><b>2 RISK MANAGEMENT</b></p> <p>Risk management is the practice of controlling or managing the factors of uncertain hazards. To Crosby, risk management requires that the risks of doing business must be reduced by concrete steps that have an impact throughout the business, from the manufacturer to user. Training and formal Product Warnings are major tools that Crosby has made available to support this effort.</p>	<ul style="list-style-type: none"> <li>• Comprehensive product literature.</li> <li>• Formal product instruction and warning program available to all users of Crosby products.</li> <li>• Many products are individually bagged or tagged with product warning and proper application information.</li> <li>• Training videos are available on several subjects.</li> <li>• Crosby Product Training Seminars are available to users.</li> </ul>
<p><b>3 RESEARCH AND DEVELOPMENT</b></p> <p>Research and Development is the ongoing effort to realize the potential of improved products resulting from scholarly and scientific investigation. At Crosby, our research and development is focused by our staff who draw upon the state-of-the-art facilities available in our centralized laboratory in Tulsa, OK.</p>	<ul style="list-style-type: none"> <li>• Development of manufacturing processes for improved product performance.</li> <li>• Enhanced material toughness and properties through the selection of raw material and proper metallurgical processing.</li> <li>• Support of the effort to provide more efficient product design utilizing less raw material and common design.</li> </ul>
<p><b>4 COMPLETE PRODUCT LINE</b></p> <p>Crosby is a worldwide company that is the premier source of blocks and fittings for the lifting and material handling industries. As a single source, Crosby offers a full line of products that is the broadest selection available to the lifting and materials handling industries.</p>	<ul style="list-style-type: none"> <li>• Scaffold pulleys to the largest lifting tackle in the world.</li> <li>• Forged Wire Rope Clips from 1/8" to 3".</li> <li>• Shackles from 1/3 ton to 1200 tons.</li> <li>• A variety of hooks from 1/3 ton to 300 tons.</li> <li>• A complete assortment of links, rings, forged swivels and thrust bearing swivels.</li> <li>• Product available in both carbon steel and alloy steel.</li> <li>• Roll Forged sheaves to "Cold Tuff" sleeves and other swaging products</li> <li>• Custom designed products to meet your specific needs.</li> </ul>
<p><b>5 CUSTOMER SERVICE</b></p> <p>"Customer Service is what the customer says it is." Crosby takes this definition seriously. We recognize that customer service begins with availability of product, order placement and tracking, and accurate information. But at Crosby we KNOW that Customer Service is more than just having the product available when you need it. It is the company-wide effort required to drive the organization to discover and meet our customers' expectations.</p>	<ul style="list-style-type: none"> <li>• Full time, knowledgeable District Sales Representatives.</li> <li>• A well trained and fully equipped Customer Service Department which can address standard products.</li> <li>• An Engineered Products Group that coordinates customers' special needs from design through manufacturing and application.</li> <li>• A Technical Support Team ready to explain our products and service.</li> <li>• A Management Team dedicated to the principle that "Customer Service is what the customer says it is."</li> </ul>
<p><b>6 ENGINEERING</b></p> <p>Engineering is the application of scientific principles to practical ends in the design, construction and use of equipment and systems. Crosby engineers its products to perform. The application of finite element analysis is but one example of the engineering expertise available at Crosby that has resulted in Crosby being considered the standard of the industry, nationally and internationally.</p>	<ul style="list-style-type: none"> <li>• Proper selected material and heat treatment process that allows for superior strength and impact and fatigue performance.</li> <li>• Active participants in professional societies and committees including ASTM, CVSA, API, ASME/ANSI.</li> <li>• Extensive expertise in computer aided design (CAD), Finite Element Analysis, Non-destructive Testing and Failure Analysis of Products.</li> <li>• ISO 9001 Certified.</li> </ul>

**Remember: "When buying Crosby, you're buying more than product, you're buying Quality."**



## Questions & Answers

**What is the Crosby Quality Continuum?**

The Crosby Quality Continuum is a symbol that identifies six segments of Crosby's business that, when viewed as one, differentiates Crosby from the competition in the marketplace. The six (6) segments are Customer Service, Engineering, Manufacturing, Risk Management, Research and Development and a Complete Product Line.

**What is the Communication System?**

The Crosby Communication System is a systematic effort to convey the positive aspects, or Value Added features of the Quality Continuum to the marketplace.

**What is the Audience for the Crosby Communication System?**

The Crosby Communication System recognizes its audience as including: Crosby employees, Authorized Crosby Distributors, End Users of Crosby, and Institutional buyers or standards setting organizations.

**What are Some of the Resources Available?**

The Crosby Communication System can successfully draw upon the many skilled and knowledgeable people within Crosby, our Video Training Programs, the product bulletins, Crosby product literature, and the product presentations that have been prepared.

**What Type of Training is Available?**

Crosby offers comprehensive product and application seminars around the world that address most Crosby product lines. Customized training sessions are also possible. In addition to product application, the sessions can also address inspection requirements, proper use, applicable standards, and importance of metallurgical properties. The training sessions may also include workshops to improve the learning experience.

**How Can This Help the User of Crosby Products?**

Crosby's users can benefit from the Crosby Communication System by recognizing the impact that Crosby's Value Added features can have on employee skills, employee safety, worker compensation costs, productivity, insurance premiums, and the ability to meet OSHA and other standards.

**How Did These Concepts Develop Through The Years?**

Crosby has always been concerned that our users be knowledgeable about the installation, use, inspection, and maintenance of our products. It was in 1987 that Crosby developed the theme "If it's Crosby, It's Quality" to highlight the Quality built into the full line of products. This evolved into the Quality Continuum concept in 1988 and 1989, when we recognized that: "When buying Crosby, you're buying more than product, you're buying Quality." Then in 1990, the Crosby Communication System was formalized.

## World Standards

### CROSBY ISO 9001

The International Standardization Organization (ISO) brought standardization to the international level in 1987 by defining three levels of quality assurance. These are ISO 9001, ISO 9002, and ISO 9003. ISO 9001 is the most comprehensive level. This level involves design, development, production, and shipping. A total of 20 quality system elements apply to ISO 9001. ISO 9001 requires that all procedures, work instructions, processes and related activities be documented.

Certification to ISO 9001 requires a "third party" audit of all facilities prior to attainment and ongoing auditing every six months.

Certification to ISO 9001 is a solid foundation on which to build and clear evidence that the organization "does what it says." Attainment of ISO 9001 forms the basis for meeting other world standards and provides customers with documented proof of the organization's ability to consistently provide product quality and performance.

Adherence to ISO 9001 is rapidly becoming a major element of purchasing contracts throughout the world.

### THE COMPETITION

**Ask:** Do they meet ISO 9001 standards?

**Ask:** Are they an ISO 9001 certified company?

**Ask:** If not, do they plan to, and do they have an implementation schedule?

**Ask:** If not, how will they support the future needs of international companies and the Department of Defense?

**Ask:** What other "world standards" of performance do they meet?



Crosby is proud to have all of our facilities, Worldwide, awarded certification for our Quality Assurance Program according to ISO 9001 by DET NORSKE VERITAS (DNV). The criteria outlined by ISO 9001 have been adopted by the company and its employees over the years at Crosby through our ongoing quality programs. Quality has been built into our products and corporate philosophy from the beginning.

"This internationally accredited certification is a true measurement of Crosby's Quality leadership, and its commitment and leadership in Quality."

Crosby made the commitment and investment needed to attain ISO 9001 certification for one reason, to support the future needs of our distributors and end users worldwide.



### AMERICAN PETROLEUM INSTITUTE (API)

The American Petroleum Institute provides third party certification for products used in the oilfield and other petroleum related activities. They provide quality assurance certification under the API-Q1 program. Manufacturers who meet their criteria qualify to manufacture under the API-Q1 program and to utilize the API monogram. API also provides design and manufacturing criteria, for API-8C. All oilfield blocks should meet API-8C criteria.

### THE COMPETITION

**Ask:** Are they certified to API-Q1?

**Ask:** Do they have capability to meet API-8C when required?



McKissick is certified under API-Q1 to manufacture blocks and sheaves for use in the oilfield. All oilfield blocks are designed and manufactured to API-8C requirements.



Licensed Under API Spec 8C-0021

### OTHER WORLD STANDARDS

American Bureau of Shipping (A.B.S.)  
 Lloyds Register of Shipping (Lloyd's)  
 DET NORSKE VERITAS (DNV)  
 Association of Belgian Industry for Safety and Health (AIB-VINÇOTTE), (AV), (VGS)  
 Control Organization of German Industry for Safety and Health (DIN)  
 Netherland Labor Inspection (AI)  
 Nuclear Regulatory Commission (NRC)  
 Defense Contract Administration Services Management Area (DCAS)  
 Registro Italiano Navale (RINA)

### THE COMPETITION

**Ask:** What world standards are they familiar with?

**Ask:** Can they demonstrate the ability to meet these standards when needed?

**Ask:** Do they have quality systems and product performance needed to document adherence to these standards?



Crosby has demonstrated capability in various countries and with many products. Crosby actively participates in standards-setting committees in both the United States and Europe. Crosby has frequently certified shackles, sheaves, blocks, and hooks to various world standards when required.

**Remember: "When buying Crosby, you're buying more than product, you're buying Quality."**



## Third Party Certification

Third Party certification by product provides one or more of the following services:

- **Inspection • Certification Service • Testing Service •**

This Certification can be confirmed to their standards, the customer's standards, or the manufacturer's own standards. Crosby, if requested at time of order, will work with you to certify any of our products to any third party organization.

### ISO 9001 CERTIFICATION PROVIDES YOU:

- **THIRD PARTY CERTIFICATION** that the Crosby Group meets the rigorous requirements of ISO 9001.
- **THIRD PARTY PROOF** that Crosby's Quality Assurance System is ongoing through a comprehensive audit program.
- **THIRD PARTY PROOF** that Crosby meets the high standards of design, manufacture and service now demanded by world markets.
- **MANUFACTURING ACCOUNTABILITY. ISO 9001** certification assures you that at Crosby, **"WE DO WHAT WE SAY WE DO"** at all of our manufacturing facilities. This, coupled with Crosby's comprehensive traceability system (P.I.C.) and our Material Verification Program provides total accountability.
- **AUDIT SAVINGS** – Sourcing from Crosby enables you the opportunity to reduce your time and cost associated with your audits or third party audits. This is due to the fact that, by being ISO 9001 certified, Crosby is regularly audited by a third party.
- **WORLD COMPETITIVENESS** – Sourcing from Crosby will allow you to participate and be competitive in more markets throughout the world. Many major end users who operate on a worldwide level have already begun to require their suppliers be ISO 9000 certified or offer products that are produced by an ISO 9001 certified source.
- **A LONG TERM PARTNER** - Crosby's ability to meet ISO 9001 standards and to maintain third party certification makes it clear that the Crosby Group is a long term partner you can depend on to provide the needed product at required performance levels. The ISO 9001 certification forms a solid foundation from which we deliver all of the value added features represented by our Quality Continuum.
- **SUPPORT** – Crosby will support committed distributors in their efforts to define and accomplish what is needed for them to attain ISO 9002 certification.



McKissick Products, Tulsa, OK  
 Lebus Manufacturing, Longview, TX  
 National Swage, Jacksonville, AR  
 Crosby Canada, Brampton, Ontario  
 N.V. Crosby Europe, Putte, Belgium



## Identification

### PRODUCT IDENTIFICATION

The most effective method of assuring that the product you are purchasing is as reliable as possible is to purchase components supplied by companies of known reputation who maintain consistent and adequate quality. The company should clearly mark its components and finished products with the company name or logo, the component size or working load limit, and a code that is actively used by the manufacturer to control material and processes.

### THE COMPETITION

- Ask:** Do they have a traceability system?
- Ask:** If yes, is their traceability system also utilized for cast fittings, swage fittings and all load-bearing components?



Crosby forges the Product Identification Code (PIC), each item's size or Working Load Limit (or a cross-reference code to working load limit) and "Crosby" or its logo into each product.

**Load Rated**

### MATERIAL TRACEABILITY

A forged-in identification code should be used to record the material grade and origin. This record should trace the material to the heat lot of material of steel as rolled at the supplying mill. Verification checks of all materials purchased for forging must be done to insure that the steel supplied meets the specifications required. This verification should be traceable by a forged-in product identification code. In summary, the source and verification of material actually used in each forging must be able to be determined through appropriate documentation.

### THE COMPETITION

- Ask:** Do they have a permanently marked code in each product that traces material back to a verified certification?
- Ask:** Do they test each heat of steel with their own testing facilities?



Crosby uses the Product Identification Code (PIC) to maintain material control from the steel mill, to receipt at our plant, to verification, and throughout the manufacturing process. Crosby can provide certified material analysis for each production lot, traceable by the Product Identification Code (PIC). Crosby, through its own laboratory, verifies the analysis of each heat of steel. Crosby purchases only special bar forging quality steel with specific cleanliness requirements and guaranteed hardenability.

### MANUFACTURING CONTROL

The permanent identification code should be used to maintain a record of which manufacturing facility produced the product as well as the approximate production dates. All quality records should reference the product identification code so that a history can be maintained. All product performance testing for audit and engineering purposes should also reference the product identification code.

### THE COMPETITION

- Ask:** Do their products have a permanent code that is used to maintain control as product is manufactured?



Crosby uses the Product Identification Code (PIC) to maintain control of its products as they are manufactured.

### PERFORMANCE & APPLICATION DATA

Detailed performance, application, and warning information will assist you in the proper use of products. This information is most effective when provided in supporting brochures and engineering information. An identification marking must be used to reference this information by use of a cross reference between the product code and the literature.

Proper performance data should include each item's working load limit, proof load and design factor. It should also include the item's manufacturing processes, such as heat treatment and galvanizing, and list any specification the product meets or exceeds.

### THE COMPETITION

- Ask:** What performance and application information do they provide?
- Ask:** Are there markings in products to aid in the proper use of the fitting?
- Ask:** Is a comprehensive product warning system provided?
- Ask:** What training support is provided?



Crosby provides a detailed catalog that comprehensively describes each product's performance. The Crosby Product Warning System provides detailed application and warning information on selected products. In addition, training seminars and videos are also available. Selected products incorporate markings forged into the product to aid in the proper use of the fitting.



**Remember: "When buying Crosby, you're buying more than product, you're buying Quality."**



## Identification and Labeling on the Product by Product Groups

	Crosby Logo	Size	Working Load Limit	Rated in Metric Tons (t)	Product Identification Code	Serial Number	QUIC-CHECK® Markings	QUIC-CHECK® RFID Equipped
SHACKLES	X	X	X	X	X		X	25t and larger
SHANK HOOKS	X	Both size and working load limit are identified with a frame size that can be referenced back to our literature.		X	X			
EYE HOOKS	X	X	X	X	X			
OTHER FORGED HOOKS	X	X			X		S-322	
SNATCH BLOCKS	X	X	X	X	X*			4-1/2" and larger
CROSBY CLIPS	X	X			X*			
FIST GRIP CLIPS	X	X			X			
TURNBUCKLES	X	X			X			
LOAD BINDERS	X	X	X		X			
EYE BOLTS	X	X			X			
LINKS	X	X			X		X	
TAPERED SWIVEL BEARINGS	X	X		X	X			
CHAIN COMPONENTS	X	X			X			
SWAGE SOCKETS	X	X			X		X	
SLEEVES & BUTTONS	X	X			X			
380 BLOCK	McKissick	X	X		X	X		X
680 BLOCK	McKissick	X	X		X	X		X
OIL FIELD	McKissick	X	X		X	X		X
750 BRIDGE CRANE BLOCKS	McKissick	X	X	X		X		X
SHACKLES CT & 2160	X	X	X	X	X	X	CT Only	X
SWIVEL HOIST RINGS	X	X	X	Selected Sizes	X			X
ELIMINATOR CHAIN	X	X			X		X	
LIFTING CLAMPS	X	X	X	X		X		X
ANGULAR CONTACT SWIVEL BEARINGS	X	X	X		X			

\* Forged Components

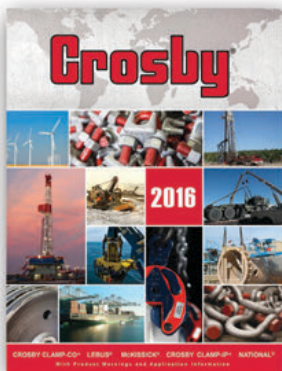

### GENERAL CATALOG

Our most comprehensive piece of literature. The Crosby general catalog contains detailed engineering specifications as well as definitions, illustrations, and drawings to assist in selecting the proper equipment for the job.



For CE-LABEL: Inquire for Full Details and Application Information.



The Market Leader: Yesterday Today and Tomorrow

## Heat Treatment

### HEAT TREATMENT

The heat treatment of steel is an ancient art science that dates back to the Iron Age. When strength and hardness of steel were needed, heat treatment provided the answer. Today the heat treatment of steel has been refined to a sophisticated science. It is now possible to greatly enhance the strength, ductility, and resilience of steel through a properly controlled heat treatment process. The "as forged" fitting results in variability that is detrimental in applications that require toughness. Normalizing, spheroidized annealing, and quench and tempering are heat treat processes. Proper heat treatment eliminates the risk of cooling variation at the forging process. This is true of all steels regardless of material grades.

### THE COMPETITION

**Ask:** Are load bearing fittings heat treated?

**Ask:** If so, what type of heat treat process is used?

Some supply critical fittings in an "as forged" or "as cast" condition.



Crosby has fully qualified heat treat operations at its plants. Utilizing these facilities, Crosby heat treats all fittings that are load bearing components. Crosby minimizes risk by the effective heat treatment of its fittings. Heat treatment is an essential element of Crosby's Risk Management Program. We do not take shortcuts for the sake of cutting cost. For the benefit of reducing cost, a non heat treated product compromises the performance ability of the product. In addition, Crosby's metallurgical laboratory provides the support needed to assure the results.

### QUENCHED AND TEMPERED

Quenching and Tempering of steel has been found to be the heat treatment best suited to fully develop the strength and enhance the grain flow of carbon and alloy forgings. The quenched and tempered product will deform before ultimate failure, thus giving warning. The quenching process is rapid cooling in water or oil, after heating, to form a strong but brittle structure. The tempering process is the reheating of the steel to obtain the desired strength while increasing the ductility and toughness. Quench and tempering provides the consistency of performance needed by all critical applications, especially overhead lifting.

### THE COMPETITION

**Ask:** What products do they quench and temper?

**Ask:** Are their products that are exposed to high stress quenched and tempered?

**Ask:** If not, why are they willing to accept inferior impact and toughness properties of non quenched and tempered products?

Many normalize their forgings, but do not quench and temper.



Crosby fittings which are exposed to high stress applications and designed as load bearing elements are quenched and tempered. The Quench and Tempering process is the most consistent method of assuring that every fitting performs as needed, especially in overhead lifting.



### MATERIAL CONTROL

The proper heat treatment of forged fittings depends on the appropriate selection of materials and use of heat treat procedures. Fine grained, special bar forging quality steel of specific cleanliness requirements and guaranteed hardenability in the appropriate grades must be used. Proper selection of steel is NOT ENOUGH, however. The control and management of these steels, from purchase through the entire manufacturing process, is essential to assure that the proper results are attained in the designated product. This control should utilize a production traceability program.

### THE COMPETITION

**Ask:** Do they have identification code forged into the product that traces material back to verified certification?

**Ask:** Are all heat records maintained by the traceability code?

Most do not provide traceability of material.



Crosby uses the Product Identification Code (P.I.C.) for material control from receipt and verification of steel, and throughout the entire manufacturing process. Crosby can provide certified material analysis for each production lot.

PIC  
Product Identification Code

### ULTIMATE STRENGTH, DUCTILITY, IMPACT & FATIGUE PROPERTIES

The mechanical properties of steel when a load is very rapidly applied is known as its *impact* strength. Forged fittings must be able to have impact strengths that match the requirements of their application, especially in cold temperatures. The ability of a steel to withstand repeated applications of a load is measured by fatigue testing. The proper heat treatment of forgings, which includes quenching and tempering, can develop these properties to their desired level in a consistent and reliable manner. The ability to perform when overloaded is known as *ductility*.

### THE COMPETITION

**Ask:** Are the products designed and manufactured with considerations for strength, fatigue, impact, and ductility?

Some do not utilize materials that have good impact and fatigue properties.



Crosby's product line benefits from the selection of steel and the heat treatment process that allows for superior strength, ductility, impact, and fatigue performance. The product deforms if overloaded, giving warning before ultimate failure. All of these properties are essential if the product is to perform time after time. They are also important to assure that the inspection criteria set forth by ANSI will effectively monitor the ability of the fitting to continue in service.

**Remember: "When buying Crosby, you're buying more than product, you're buying Quality."**



Heat Treatment Process by Product Groups	
PRODUCT	HEAT TREATMENT
SHACKLES	Bows - Quenched and Tempered Pins - Quenched and Tempered
EYE HOOKS	Quenched and Tempered
SHANK HOOKS	Quenched and Tempered
LINKS	Quenched and Tempered
RINGS	Quenched and Tempered
SWIVELS	Quenched and Tempered
TURNBUCKLES	All ends are Quenched and Tempered or Normalized Bodies Normalized
PAD EYES	Quenched and Tempered
EYE BOLTS	Quenched and Tempered
LOAD BINDERS	Quenched and Tempered
SWAGE SOCKETS	Spheroidized Annealed
SWAGE SLEEVES	Cold Tuff. A proprietary heat treat process that maximizes swageability of the sleeve at low temperatures.
SPELTER SOCKETS	Normalized

## MICROSTRUCTURES FOR VARIOUS HEAT TREATMENT PROCESSES

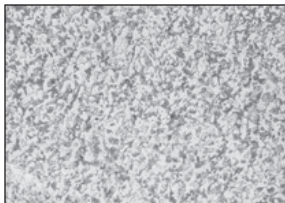

AS FORGED

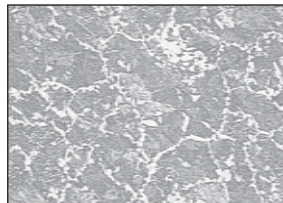

NORMALIZED

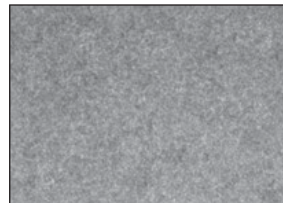

QUENCHED AND TEMPERED

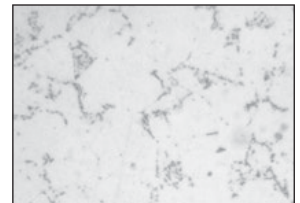

COLD TUFF®



*Remember: "When buying Crosby, you're buying more than product, you're buying Quality."*

The Market Leader: Yesterday Today and Tomorrow

## Material Properties

### PROCESS IS IMPORTANT

The material used in a forged fitting, such as carbon or alloy steel, determines the potential properties. The manufacturing processes determine what the properties will actually be. The material must be special bar forging quality steel and fine grained. The heating of steel to forging temperature must be properly controlled to insure that the steel is not "injured" by overheating. Proper forging equipment and techniques must be employed to assure proper material flow in the dies and tooling. The heat treatment process must be well defined and precisely controlled.

### THE COMPETITION

- Ask:** *What processes do they consider important?*
- Ask:** *How do they select their material?*
- Ask:** *Is the steel fine grained?*
- Ask:** *Are standards established to insure sufficient cleanliness of the steel?*



Crosby's attention to material selection, forging techniques, machining, and heat treatment processes assures the properties required will be attained, thus providing superior performance of the product. Crosby has specific and demanding cleanliness requirements. Crosby provides a video on metallurgy that highlights these facts.

### TENSILE STRENGTH & DUCTILITY

The mechanical properties that are important when lifting a load under normal conditions are tensile strength and ductility. The ability to carry a load increases with the tensile (pulling) strength of the steel. The ability of steel to deform in an overload condition is known as its ductility. Both of these factors enter greatly into determining the working load limit of a forging. Ductility is measured by standard engineering tests of elongation and reduction of area. It is also measured by how much deformation the fitting incurs when overloaded. The tensile strength determines the actual working load, while ductility allows the product to deform significantly when overloaded, thus giving warning before ultimate failure.

### THE COMPETITION

- Ask:** *Do they have an active program to determine tensile and ductility properties?*
- Ask:** *Are testing audits performed continuously on all products?*
- Ask:** *Is the actual deformation of a fitting when overloaded a major consideration for their shackles?*



Crosby has an active program to determine tensile and ductility properties. Testing audits are continuously performed on all products. Crosby's design philosophy considers the deformation of a fitting when loading is a key requirement.

### FATIGUE PROPERTIES

The mechanical properties of steel when a load is repeatedly applied is known as its fatigue strength. Fatigue testing determines the ability of a material to withstand repeated applications of a load. The load by itself may be too small to produce a failure. There are three factors involved when considering fatigue strength. They are: the number of cycles at which a crack initiates, the number of cycles at which the crack starts to grow, and the number of cycles at which the fitting fails. One accepted method of fatigue rating fittings is to test them to 1-1/2 times the working load limit for 20,000 cycles, without failure. This standard test is accepted as indicating indefinite life when used within the working load limit under normal circumstances.

### THE COMPETITION

- Ask:** *Does the material selection process recognize fatigue properties?*
- Ask:** *Do they have an active program to "design in" and test fatigue properties?*
- Ask:** *Is there a program in place to fatigue rate all load bearing products that are used in critical applications?*



Crosby has an active program to determine fatigue properties. Included in this program is the use of finite element design methods to predict possible weak areas, which in turn allows us to design in superior fatigue properties. Crosby specifies material of specific cleanliness and guaranteed hardenability which enhances fatigue. Crosby designs and manufactures its products with fatigue in mind. Crosby has a program in place that will result in all load bearing products used in critical applications being fatigue rated.

### IMPACT PROPERTIES

The mechanical properties of steel when a load is very rapidly applied is known as its impact strength. Impact tests are made by applying a sudden load to a test piece and measuring the energy absorbed when the specimen breaks. The "tougher" the material, the greater the energy required to break the piece. A brittle piece can absorb virtually no energy upon breaking. The Charpy V Notched Impact test is one common method of performing the testing and measurement. Fittings must be able to have impact strengths that match the requirements of their application at all temperatures, even low temperatures commonly found in winter conditions. The difficulty of crack initiation and crack growth under impact is an important consideration.

### THE COMPETITION

- Ask:** *Does the material selection process recognize impact properties?*
- Ask:** *Do they have an active program to perform actual testing of impact properties?*
- Ask:** *Do they recognize the need for good impact properties, i.e., the need for crack initiation and growth to be difficult throughout the normal operating temperature of 0° to 75° F (-20°C + 25°C)?*



Crosby recognizes the importance of impact properties and has an active program to determine impact properties at various temperatures of each material used in the various heat treat conditions. Crosby products are designed to be used in a wide range of temperatures. Crosby specifies material of specific cleanliness and guaranteed hardenability which enhances fatigue and impact properties.

### PERFORMANCE

Performance of a fitting requires a tensile strength that meets working load limits, ductility that allows deformation when overloaded, fatigue properties that support use time after time, and impact properties that provide toughness. All of these properties are essential if the product is to perform time after time in adverse conditions. They are also important to assure that the inspection criteria set forth by ANSI will effectively monitor the ability of the fitting to continue in service.

### THE COMPETITION

- Ask:** *Does the fitting have required tensile strength, ductility, fatigue and impact properties?*
- Ask:** *Are all the material properties met?*



Crosby designs its fittings to include required working load limits and design factors. Equally important are the ductility, fatigue, and impact properties. Crosby provides you with material properties that minimize the risk of failure. No shortcuts in processing are made to save cost while sacrificing any of these performance elements.



Material Properties by Product Groups		
PROPERTY	DESCRIPTION	PRODUCT GROUP*
<b>TENSILE STRENGTH</b>	Crosby can provide typical hardness, tensile, and typical yield strength values.	Hooks, Shackles, Turnbuckles, and Chain Fittings
<b>DUCTILITY</b>	Crosby can provide typical reduction of area and elongation values upon special request.	Hooks, Shackles, Turnbuckles, and Chain Fittings
<b>IMPACT PROPERTIES</b>	Crosby's quenched and tempered products have enhanced impact properties for greater toughness at all temperatures. If requested at the time of order, Crosby can provide Charpy impact properties.	Hooks, Shackles, Turnbuckles, and Chain Fittings
<b>FATIGUE PROPERTIES</b>	Crosby products are being designed to meet specific fatigue performance levels. If requested at the time of order, these fatigue properties can be provided.	Hoist Hooks, Shackles, Eye Bolts, Turnbuckles, Swivel Hoist Rings, Chain Fittings and Snatch Blocks are Fatigue rated to 20,000 cycles at 1-1/2 times the Working Load Limit.
<b>PROOF TESTING</b>	Proof testing and certification are furnished standard with some products. If requested at the time of order, proof testing certification can be provided on most of Crosby's remaining product line, with the exception of products such as swage sockets and sleeves, spelter sockets, thimbles, etc.	All Products
<b>QC 1400 AUDITS</b>	Crosby's QC 1400 program provides reduction of area, elongation values, as well as hardness, tensile, and yield strength values for each production lot of hoist hooks. These factors are traceable by the Product Identification Code (PIC) program.	Hoist Hooks Only
<b>MAG CERTIFICATION, ULTRA SONIC, X-RAY, AND DYE PENETRANT TESTING</b>	If requested at the time of order, different non-destructive testing and certification is available.	All Products
<b>CHEMISTRY ANALYSIS</b>	Each heat of steel is individually verified to confirm chemical analysis prior to manufacturing.	All Products

\* Products listed are those most commonly requested to be provided with specified properties. The material properties may also be available on other products upon request.





# Crosby® *The Market Leader Yesterday, Today and Tomorrow.*

Since 1889 The Crosby Group has been driven to become the single source for accessories used in the lifting and material handling industry. Growing through product development, uncompromising quality and aggressive acquisitions of market leading companies, Crosby moves forward towards this goal. In the future, as in the past, look to Crosby for innovation, education and product leadership.



**1893**  
Crosby's first patent, the Crosby "Red-U-Bolt®" clip is one of the most recognizable products in the material handling industry. The standard by which all others are measured.

## Load Rated

**1958**  
A registered Crosby trademark that identifies products that have the Working Load Limit indicated or affixed to it. An industry first, Crosby pioneered the assignment of capacity to each product, allowing distributors and product users to select the proper components for rigging system.



**1977**  
McKissick's Roll Forged sheave technology, featuring an upset process for the groove, provided the first precision made sheave that eliminated variations inherent in castings.

## COLD TUFF®

**1978**  
Crosby patented a heat treat process that resulted in fittings that swaged easier while maintaining proper wire rope efficiencies. The COLD TUFF® process virtually eliminated cracking of fittings during the swaging process.

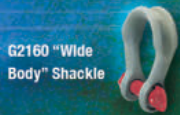

62160 "Wide Body" Shackle

**1981**  
The Original! Crosby introduced a new shackle whose patented features provided increased strength and improved sling life over conventional shackles.



**1991**  
Introduced the Crosby Quality Q. The basis for our industry leading training program. These training programs have provided support to our distributors and helped our product users improve rigging safety and meet industry standards.

## QUIC-CHECK®



**1992**  
QUIC-CHECK® is a patented concept developed by Crosby that incorporates the strategic placement of marking indicators on traditional rigging products. These marks are used to indicate reference points designed to enhance the safe and proper use of Crosby products.



**1995**  
Already the most requested eye hoist hook in the industry, the new 320N incorporated many new features that made it a world class hook, including a fully integrated locking latch.

## Fatigue Rated

**1997**  
Fatigue Rated® is a registered Crosby trademark that identifies products that have proven to provide improved fatigue life (fatigue resistance) in actual use. Products are tested at 1-1/2 times working load limit for 20,000 cycles, representing infinite product life.

## QUIC-PASS®

**1999**  
The next generation in swaging systems, the National QUIC-PASS® System allows the termination to be swaged in two passes, while maintaining currently published efficiency ratings with the use of National S-505 Standard Steel sleeves.

## MAXTOUGH



**2005**  
MAXTOUGH® is a registered Crosby trademark identifying products that are statistically verified to meet or exceed impact values of 31 ft-lbs. at -4°F based on a high confidence level.

**2009**  
The Split-Nut innovation makes crane block hooks easier to service and inspect.

## McKISSICK



**2012**  
Our innovative bolt securement system utilizes a hinged split collar assembly that eliminates the traditional threaded bolt, nut and cotter pin.

## Crosby Easy-Loc



**1925**  
McKissick® developed and patented the first wire line guard that could be opened and allow the reeving of the block without disassembly.



**1973**  
As an industry leader in metallurgy, Crosby perfected the Quench & Tempering® method of heat treatment of steel. The process has been found to be the method best suited to fully develop the strength and enhance the grain flow of carbon and alloy forgings.



**1977**  
Crosby was the first to use a comprehensive Product Identification Code (PIC) to maintain material control from the steel mill through the manufacturing process. All load bearing components contain a PIC.



**1980**  
Crosby introduced a "company wide" 2D computer aided design software that improved the processing of product enhancements and new product development. CAM technology allowed dies to be sunk and tooling developed much more efficiently.

## 2D computer aided design

**1989**  
Crosby set the standard again, when we were the first in our industry to develop an intensive product warning and application system that focused on the proper usage of Crosby products.



**1992**  
Crosby achieved all five manufacturing facilities certified to ISO standards in six months. A testament to our quality standards.



**1994**  
Crosby recognized the growing acceptance of synthetic slings in the lifting industry, and was the first to develop a line of fittings exclusively for use with synthetic slings. From web sling shackles to the High Performance Sling Connector, the line continues to broaden to meet the needs of the industry.

## Sling Saver®

**1996**  
The innovative, patented design of the Crosby TERMINATOR® modernized the wedge and socket product by securing the tail or "dead end" of the wire rope to the wedge, thus eliminates loss or punch out" of the wedge.



**1998**  
Crosby was the first in the industry to provide an interactive CD-rom catalog containing over one hour of video and several comprehensive calculators designed to enhance everyday rigging tasks. This development has been followed by a series of computer tools to assist in selecting and using Crosby products.



**1998**  
Crosby was the first in the industry to implement a full scale web site that provided important product information, including a fully interactive product catalog.

[www.thecrosbygroup.com](http://www.thecrosbygroup.com)

**2007**  
Crosby was the first in the industry to provide product "factory equipped" with RFID chips that, when used in conjunction with available software (i.e., Crosby QUIC-CHECK Inspection and Identification System), provides an innovative, streamlined and automated approach to the hardware inspection process. Patented



**2011**  
2011 marked the addition of creating some of our most popular value added reference guides into mobile apps.

- User's Guide for Lifting
- Block Selection and Application Guide
- Sling Calculator



Crosby's apps are an example of our ongoing commitment to utilize the latest technology in order to provide the information required to ensure the proper application of our products.





Understanding:

---

# The Crosby Group Product Warnings



# Product Warning and Application Information and Their Importance to You.

*“Men who value lives and loads . . . ”* is more than just a slogan to the Crosby Group. It is a constant reminder to us that our products are often in work environments which can be dangerous. It is also a constant reminder that our products must remain of the highest quality and design.

Our products are used as components of a *“Work System”* for lifting, towing, tying down, and hauling. Used properly in such a *“Work System,”* Crosby products have been proven to be among the best designed and safest in our industry. Used improperly, however, a *“Work System”* can be rendered inefficient and unsafe. It is absolutely critical that those who use our products be trained in how to use them correctly. Designing and fabricating rigging properly requires specialized training. If you or your employees lack proper training in approved rigging practices, **DO NOT ATTEMPT TO DESIGN OR FABRICATE ANY RIGGING.**

In addition to providing high quality products, we also provide warning and application instructions for our products. These warnings and instructions are only a portion of our entire customer communication system that we use to disseminate information concerning product warnings and application instructions.

These warnings and application instructions are reviewed and discussed with Distributors and End Users, and revised when appropriate. Our commercial literature discusses Safety issues before presenting any other product information. We provide product safety literature to our Distributor network for sharing with their customers. It would be impossible for any warnings to contain all of the possible misapplication associated with the use of Crosby products. Crosby warnings are intended to identify only those risks which are most common. As a rigging or designer of rigging, it is your explicit responsibility to consider the risk factors prior to putting any rigging device or products into use.

We have also produced the brochure *“Understanding: The Crosby Group Product Warnings”* to further enhance our existing warning and application instructions. We strongly recommend that you read it, use it in your Safety Training Programs, and make it available to the product users such as your customers and those who work in your facilities. If you would like to receive additional copies, please contact your Crosby Group Representative or contact us direct at the address shown in the front of this catalog or telephone us at (1-800-772-1500).

Working together, we can ensure that *“Men who value lives and loads”* will continue to use Crosby products confidently and safely.

***Remember: “When buying Crosby, you’re buying more than product, you’re buying Quality.”***



## CROSBY WARNING ELEMENTS

Let's turn to the basic elements and formats of the Crosby Group warnings. In most Crosby warnings, four basic elements or types of information are provided:

1. A "Signal Word" such as "DANGER", "WARNING", or "CAUTION." This word is meant to attract the attention of the user to the warning statement. The signal word also identifies the degree of potential danger or risk in using the product.
2. A "Hazard Statement" such as "FAILURE TO USE TACKLE BLOCK CORRECTLY MAY CAUSE LOAD TO SLIP OR FALL." This statement is meant to inform or remind the user of factors involved in the task or work environment that can create a hazard.
3. A "Consequence Statement" such as "FAILURE TO FOLLOW APPLICATION INSTRUCTIONS MAY RESULT IN SERIOUS INJURY OR DEATH." This statement is meant to inform or remind the user that failure to avoid the hazard can have harmful consequences.
4. An "Instruction Statement" such as "PREPARE WIRE ROPE TERMINATION ONLY AS INSTRUCTED." This statement is meant to inform or remind the user of the proper steps or procedures for using the product safely and avoiding the hazard.

## SIGNAL WORDS

In Crosby warnings, a "signal word" is used to attract attention of the user to the warning. As indicated below, another purpose of the signal word is to identify the level of risk or hazard involved. Sometimes, the signal word will be accompanied by a "safety alert symbol" such as an exclamation point inside a triangle. As discussed later in this catalog, the signal word will always appear within a box or panel separated from the remainder of the warning by a border and, in some cases, may have a contrasting background color such as red, orange, or yellow. The majority of Crosby warnings use the signal words:



This indicates a situation in which a hazard is imminent and will result in a high probability of serious injury or death.



This indicates a potential hazardous situation which could result in some probability of serious injury or death.



This indicates a potential hazardous situation which could result in minor injury or moderate injury.

Crosby warnings use these signal words for alerting product users to potential hazards which can result in personal injury or death. For hazards involving potential damage to property, Crosby uses other signal words such as "IMPORTANT" or "NOTICE."

# WARNING COLOR CODES

Some Crosby warnings will use a contrasting color within the warning to reinforce the word message and/or to attempt to draw attention of the user to the warning message. When colors are used for these purposes, they will appear as background for the signal word panel.

Three colors are used in the Crosby warning system:

RED	ORANGE	YELLOW
<p>This will appear in some warnings which use the signal word "DANGER," indicating the highest degree of risk. When red is used in the signal word panel, white letters are used for the word "DANGER." If a safety alert symbol is used along with the signal word, such as an exclamation mark inside of a triangle, the triangle will be solid white and the exclamation mark will be red.</p>	<p>This will appear in some warnings which use the signal word "WARNING." When orange is used in the signal word panel, black letters are used for the word "WARNING." If a safety alert symbol is used along with the signal word, such as an exclamation mark inside of a triangle, the triangle will be solid black and the exclamation mark will be orange.</p>	<p>This will appear in some warnings which use the signal word "CAUTION." When yellow is used in the signal word panel, black letters are used for the word "CAUTION." If a safety alert symbol is used along with the signal word, such as an exclamation mark inside of a triangle, the triangle will be solid black and the exclamation mark will be yellow.</p>

# WARNING FORMAT

Crosby warnings on tags, labels, and within application instructions are displayed in a similar format. Warnings are usually set apart from other information by a border, contrasting color, or both. Typically, Crosby warnings are displayed in a "box," set apart by a border, and consisting of two or three "panels within the box." Specifically:

- The signal word (and alert symbol if used) appears in the upper panel of the box.
- The hazard statement, consequence statement, and instruction statement appears in the lower panel of the box.
- In a warning which uses three panels, the third panel will be pictorial which also identifies the hazard or indicates how to avoid the hazard.

Here is an example of the Crosby Warning for Forged Eye Bolts, demonstrating the alert, hazard, consequence and instruction elements:

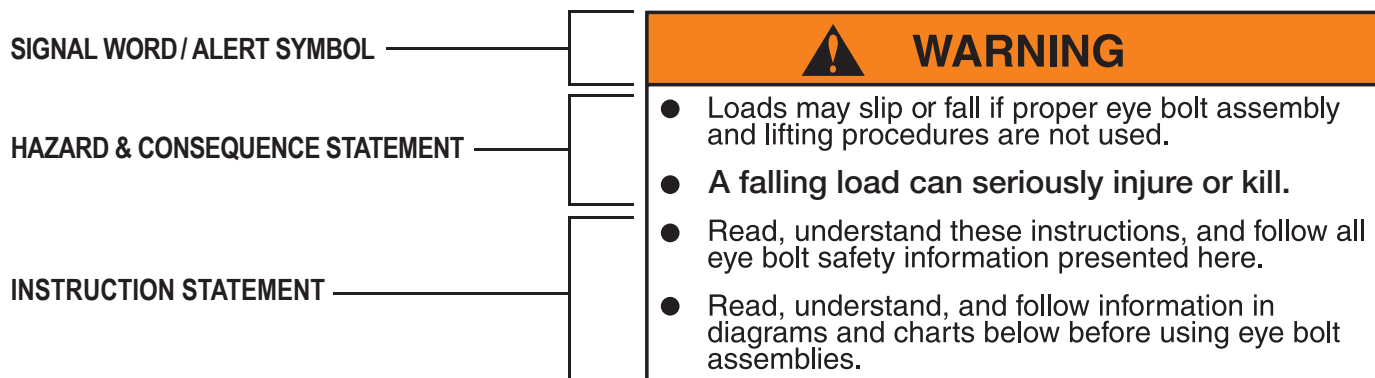





# WIRE ROPE END FITTINGS

With Product Warning and Application Information





**Crosby**

# "There is No Equal"



The Market Leader: Yesterday Today and Tomorrow

## Wire Rope End Fittings

### FORGED FOR CRITICAL APPLICATIONS

The proper performance of forged clips depends on proper manufacturing practices that include good forging techniques and accurate machining. Forged clips provide a greater rope bearing surface and more consistent strength than malleable cast iron clips. Fist Grip clips provide a saddle for both the "live" and the "dead" end. Fewer forged clips are required for each termination than with malleable cast iron clips. Forged clips reduce the possibility of hidden defects that are sometimes present in malleable cast iron clips. Malleable cast iron clips should only be used in non-critical applications. ANSI, OSHA, and ASTM recommend only forged clips for critical applications.

### THE COMPETITION

**Ask:** *Is the clip forged?*  
**Ask:** *Is an adequate cradle provided in the clip base for the wire rope?*

Malleable cast iron clips are sometimes improperly used as replacements for forged clips.

**Crosby**

Crosby provides forged "Red" U-Bolt® Clips and forged Fist Grip clips which meet or exceed Federal Specification Number FF-C-450 and are considered the industry standard.

### FULL LINE

The proper application of forged clips requires that the correct type, size, number, and installation instructions be used (See APPLICATION INFORMATION below for more information). Availability of a full range of sizes of forged U-bolt clips and forged Fist Grip clips are essential for design flexibility.

### THE COMPETITION

**Ask:** *Do they have both Fist Grip and U-bolt clips available?*  
**Ask:** *Do they have a full range of forged wire rope clip sizes?*

No competitor has the full line of forged U-Bolt clips and Fist Grip clips that Crosby has.

**Crosby**

Only Crosby provides forged "Red" U-Bolt® Clips from 3.18mm to 88.9mm\* and forged Fist Grip clips from 4.76mm through 38.1mm.

\* The 88.9mm base is a steel casting.

### IDENTIFICATION

The clip's size, manufacturer's logo, and a traceability code should be clearly embossed in the forging of the clip. These three elements are essential in developing total confidence in the product.

### THE COMPETITION

**Ask:** *Is the manufacturer's name and size of clip clearly marked?*  
**Ask:** *Do they have a traceability system that is actively used in the manufacturing process?*

Most do not have a traceability system.

**Crosby**

Crosby clearly embosses its logo, the size, and the Product Identification Code (PIC) into all Crosby "Red" U-bolt® Clip bases and Fist Grip clips. Crosby's traceability system is actively used throughout the manufacturing of forged clips. The material analysis for each heat of steel, is verified within our own laboratory.

### APPLICATION INFORMATION

Detailed application information will assist you in the proper installation of wire rope clips. This information is most effective when provided at the point of application, as well as in supporting brochures and engineering information. The manufacturer must provide this specific information. Generic information will not provide all the needed application instructions. A formal application and warning system that attracts the attention of the user, clearly informs the user of the factors involved in the task, and informs the user with the proper application procedures as needed.

### THE COMPETITION

**Ask:** *Does each clip have the application and warning information?*

Most competitors do not have application and warnings information with each clip.

**Crosby**

Crosby provides detailed application and warning information for all forged clips. Each clip is individually bagged or tagged with the application and warning information. Testing and evaluation of special applications can be performed upon special request.

**Remember: "When buying Crosby, you're buying more than product, you're buying Quality."**



# Crosby® VALUE ADDED

- **Full Line:** Crosby provides both forged “Red” U-Bolt® Clips and forged Fist Grip Clips.
- **Forged:** Crosby “Red” U-Bolt® Clips have forged bases on all sizes, except 88.9mm (the 88.9mm base is a steel casting). The entire clip is galvanized to resist corrosive and rusting action. Clip sizes 3.18mm through 38.1mm have U-Bolts with rolled threads which enhance the strength of the material and fatigue properties.
- **Forged:** Fist Grip Clips are forged, and the entire clip is galvanized. The double saddle design eliminates the possibility of incorrect installation. Designed as an integral part of the clip, the bolts are opposite one another (see G-429 example below). As result, the nuts can be installed in such a way as to enable the operator to swing the wrench in a full arc for ease of installation.
- **Application Information:** Application and warning information is available for both Crosby “Red” U-Bolt® Clips and Fist Grip Clips. The Crosby Warning System is designed to attract the attention of the user, clearly inform the user of the factors involved in the task, and provide the user with proper application procedures. Each Crosby “Red” U-Bolt® Clip and Fist Grip Clip is either bagged or tagged with appropriate application and warning information, thus ensuring that the information is available at the point of application for each and every clip during installation.
- **Material Analysis:** Crosby can provide certified material (mill) analysis for each production lot, traceable by the Product Identification Code (PIC). Crosby, through its own laboratory, verifies the analysis of each heat of steel.
- **Testing:** Crosby periodically audits the termination efficiencies of the “Red” U-Bolt Clips and Fist Grip Clips. Upon special request, Crosby will determine the efficiencies of clip assemblies when applied to special rope constructions and special applications.



## Forged Wire Rope Clips



**G-450**  
Red-U-Bolt® Clip

Crosby Clips, all sizes except 68-72mm and 85-90mm meet the performance requirements of EN13411:2003. Crosby Clips, all sizes 6 mm and larger, meet the performance requirements of Federal Specification FF-C-450 TYPE 1 CLASS 1, except for those provisions required of the contractor. For additional information, see page 474.

- Each base has a Product Identification Code (PIC) for material traceability, the name CROSBY or CG, and a size forged into it.
- Based on the catalog breaking strength of wire rope, Crosby wire rope clips have an efficiency rating of 80% for 3mm through 22mm sizes, and 90% for sizes 24mm through 90mm.
- Entire Clip is galvanized to resist corrosive and rusting action.
- Sizes 3mm through 62mm and 75mm have forged bases.
- All Clips are individually bagged or tagged with proper application instructions and warning information.
- Clip sizes up through 38mm have rolled threads.
- Meets or exceeds all requirements of ASME B30.26 including identification, ductility, design factor, proof load and temperature requirements. Importantly, these wire rope clips meet other critical performance requirements including fatigue life, impact properties and material traceability, not addressed by ASME B30.26.
- Look for the Red-U-Bolt®, your assurance of Genuine Crosby Clips.



### G-450 Crosby® Clips

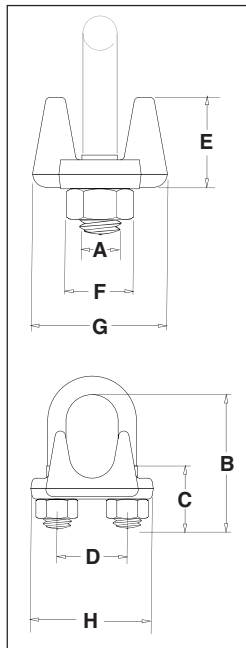

Rope Size		G-450 Stock No.	Std. Package Qty.	Weight Per 100 (kg)	Dimensions (mm)							
(mm)	(in.)				A	B	C	D	E	F	G	H
3-4*	1/8*	1010015	100	2.72	5.60	18.3	11.2	11.9	10.4	9.65	20.6	23.9
5*	3/16*	1010033	100	4.54	6.35	24.6	14.2	15.0	12.7	11.2	23.9	29.5
6-7	1/4	1010051	100	8.62	7.85	26.2	12.7	19.1	16.8	14.2	30.2	36.6
8	5/16	1010079	100	12.7	9.65	35.1	19.1	22.4	18.3	17.5	33.3	42.9
9-10	3/8	1010097	100	21.8	11.2	38.1	19.1	25.4	23.1	19.1	41.4	49.3
11	7/16	1010113	50	35.4	12.7	47.8	25.4	30.2	26.2	22.4	46.0	58.0
12-13	1/2	1010131	50	36.3	12.7	47.8	25.4	30.2	28.7	22.4	48.5	58.0
14-15	9/16	1010159	50	49.4	14.2	57.0	31.8	33.3	31.0	23.9	52.5	63.5
16	5/8	1010177	50	49.9	14.2	60.5	31.8	33.3	34.0	23.9	52.5	63.5
18-20	3/4	1010195	25	64	15.7	70.0	36.6	38.1	35.8	26.9	57.0	72.0
22	7/8	1010211	25	96	19.1	79.0	41.1	44.5	40.4	31.8	62.0	80.5
24-26	1	1010239	10	114	19.1	89.0	46.0	47.8	45.2	31.8	67.0	88.0
28-30	1-1/8	1010257	10	128	19.1	98.5	51.0	51.0	48.5	31.8	71.5	91.0
32-34	1-1/4	1010275	10	199	22.4	108	54.0	59.4	55.5	36.6	79.5	105
36	1-3/8	1010293	10	200	22.4	118	58.5	59.4	58.5	36.6	79.5	106
38	1-1/2	1010319	10	247	22.4	125	60.5	66.5	62.0	36.6	86.5	113
41-42	1-5/8	1010337	Bulk	319	25.4	135	66.5	70.0	67.5	41.4	92.0	121
44-46	1-3/4	1010355	Bulk	424	28.7	146	70.0	77.5	74.5	46.0	97.0	134
48-52	2	1010373	Bulk	590	31.8	164	76.0	86.0	77.0	51.0	113	149
56-58	2-1/4	1010391	Bulk	726	31.8	181	81.0	98.5	81.0	51.0	114	162
62-65	2-1/2	1010417	Bulk	862	31.8	195	87.5	105	93.5	51.0	119	168
** 68-72	** 2-3/4	1010435	Bulk	1043	31.8	211	90.5	111	124	51.0	127	175
75-78	3	1010453	Bulk	1406	38.1	233	98.5	121	119	60.5	149	194
** 85-90	** 3-1/2	1010426	Bulk	1814	38.1	273	114	140	152	60.5	157	213

\* Electro-plated U-Bolt and Nuts. \*\* 70mm and 89mm base is made of cast steel.



**SS-450**  
Stainless Steel  
Wire Rope Clips

- Each base has a Product Identification Code (PIC) for material traceability, the name CROSBY or "CG", and a size forged into it.
- Entire clip is made from 316 Stainless Steel to resist corrosive and rusting action.
- All components are Electro-Polished.
- All Clips are individually bagged or tagged with proper application instructions and warning information.

### SS-450 Stainless Steel Wire Rope Clips

Rope Size		SS-450 Stock No.	Std. Package Qty.	Weight Per 100 (kg)	Dimensions (mm)							
(mm)	(in.)				A	B	C	D	E	F	G	H
3-4	1/8	1011250	Bulk	2.72	5.60	18.3	11.2	11.9	10.4	9.65	20.6	23.9
5	3/16	1011261	Bulk	4.54	6.35	24.6	14.2	15.0	12.7	11.2	23.9	29.5
6-7	1/4	1011272	Bulk	9.07	7.85	26.2	12.7	19.1	16.8	14.2	30.2	36.6
9-10	3/8	1011283	Bulk	21.3	11.2	38.1	19.1	25.4	23.1	19.1	41.4	49.3
12-13	1/2	1011305	Bulk	34.9	12.7	47.8	25.4	30.2	28.7	22.4	48.5	58.0
16	5/8	1011327	Bulk	48.1	14.2	60.5	31.8	33.3	34.0	23.9	52.5	63.5



# Fist Grip® Wire Rope Clips



**G-429**  
Fist Grip® Clip  
5mm - 16mm

Fist Grip® wire clips meet or exceed the performance requirements of Federal Specification FF-C-450 Type III, Class 1, except for those provisions required of the contractor. For additional information, see page 474.

- Entire clip is Galvanized to resist corrosive and rusting action.
- Based on the catalog breaking strength of wire rope, Crosby wire rope clips have an efficiency rating of 80% for 5mm - 22mm sizes, and 90% for sizes 24mm through 40mm.
- Bolts are an integral part of the saddle. Nuts can be installed in such a way as to enable the operator to swing the wrench in a full arc for fast installation.
- All sizes have forged steel saddles.
- All Clips are individually bagged or tagged with proper application instructions and warning information.
- Meets or exceeds all requirements of ASME B30.26 including identification, ductility, design factor, proof load and temperature requirements. Importantly, these wire rope clips meet other critical performance requirements including fatigue life, impact properties and material traceability, not addressed by ASME B30.26.
- Assembled with standard heavy hex nuts.



**G-429**  
Fist Grip® Clip  
19mm - 38mm

5mm - 16mm

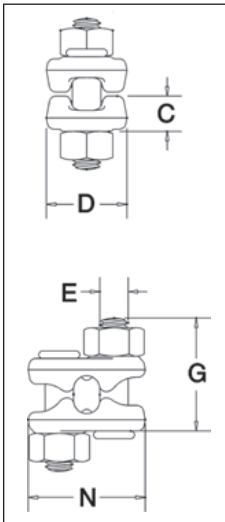

## G-429 Fist Grip® Clips

Rope Size		G-429 Stock No.	Std. Package Qty.	Weight Per 100 (kg)	Dimensions (mm)				
(mm)*	(in.)				C	D	E	G	N
5-7	3/16 - 1/4	1010471	100	10.4	10.2	23.9	9.65	32.5	36.6
8	5/16	1010499	100	12.7	11.9	26.9	9.65	37.3	39.1
10	3/8	1010514	50	18.1	13.0	26.9	11.2	46.0	45.2
11-13	7/16 - 1/2	1010532	50	28.1	15.0	31.8	12.7	55.5	54.6
14-16	9/16 - 5/8	1010550	50	46.7	18.3	38.1	16.0	68.5	65.3
18-20	3/4	1010578	25	79	21.8	46.0	19.1	74.5	67.8
22	7/8	1010596	25	102	24.6	53.8	19.1	84.0	72.6
24-26	1	1010612	10	136	28.7	57.0	19.1	94.5	77.7
28-30	1-1/8	1010630	10	181	32.5	60.5	22.4	107	87.4
32-34	1-1/4	1010658	10	181	34.0	63.5	22.4	108	90.4
36-40	1-3/8 - 1-1/2	1010676	Bulk	318	39.6	76.0	25.4	141	105

\* Sizes through 16mm incorporate New Style Design.

19mm - 38mm

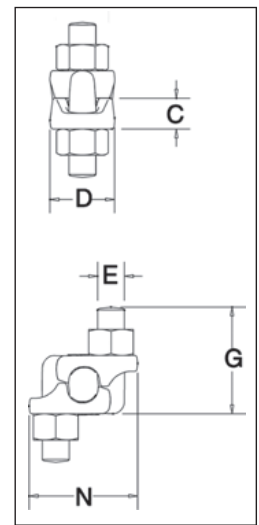

**YouTube**

**WIRE ROPE CLIPS TRAINING VIDEO**  
CROSBY G-450 & G-429

Scan this QR code with your smart device to view video.

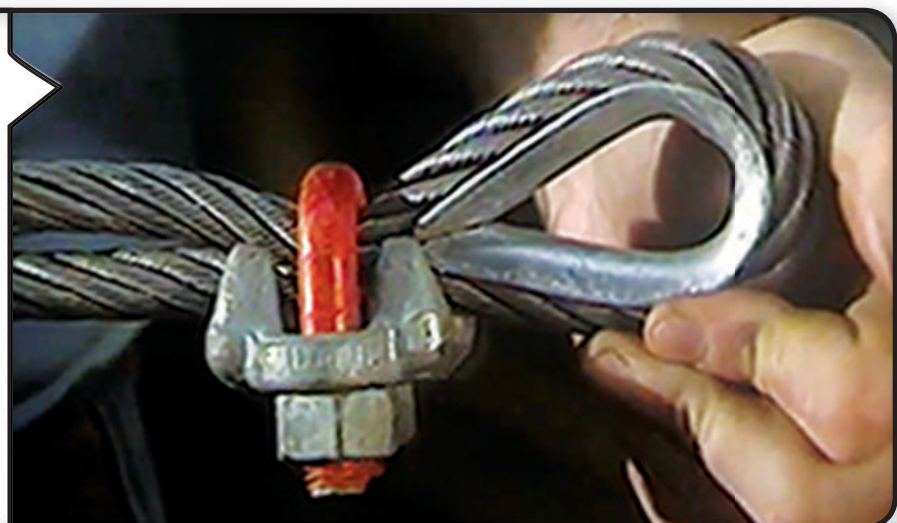

**WIRE ROPE END FITTINGS**



### S-421T

Wedge sockets meet the performance requirements of Federal Specification RR-S-550E, Type C, except those provisions required of the contractor. For additional information, see page 452.

- Wedge socket terminations have an efficiency rating of 80% based on the catalog strength of XXIP wire rope.
- Meets or exceeds all requirements of ASME B30.26 including identification, ductility, design factor, proof load and temperature requirements. Importantly, these sockets meet other critical performance requirements including fatigue life, impact properties and material traceability, not addressed by ASME B30.26.
- Type Approval and certification in accordance with ABS 2007 Steel Vessel Rules. 1-1-17.7, and ABS Guide for Certification of Cranes.
- Basket is cast steel and individually magnetic particle inspected.
- Pin diameter and jaw opening allows wedge and socket to be used in conjunction with closed swage and spelter sockets.
- Secures the tail or “dead end” of the wire rope to the wedge, thus eliminates loss or “Punch out” of the wedge.
- Eliminates the need for an extra piece of rope, and is easily installed.
- The TERMINATOR™ wedge eliminates the potential breaking off of the tail due to fatigue.
- The tail, which is secured by the base of the clip and the wedge, is left undeformed and available for reuse.
- Incorporates Crosby’s patented QUIC-CHECK® “Go” and “No-Go” feature cast into the wedge. The proper size rope is determined when the following criteria are met:
  - 1) The wire rope should pass thru the “Go” hole in the wedge.
  - 2) The wire rope should NOT pass thru the “No-Go” hole in the wedge.
- Utilizes standard Crosby Red-U-Bolt® wire rope clip.
- The 9-10mm through 28mm standard S-421 wedge socket can be retrofitted with the new style TERMINATOR wedge.
- **Available with Bolt, Nut, and Cotter Pin.**
- U.S. patent 5,553,360, Canada patent 2,217,004 and foreign equivalents.
- Meets the performance requirements of EN 13411-6: 2003.

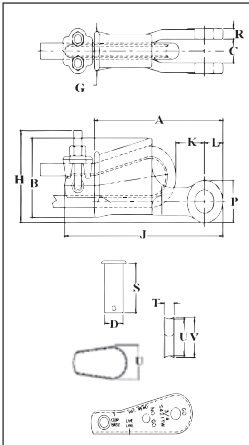

Scan this QR code with your smart device to view our Terminator video.



## S-421T WEDGE SOCKETS (Assembly includes Socket, Wedge, Pin and Wire Rope Clip)

Wire Rope Dia.		S-421T Stock No.	API 2C S-421T Stock No.	Weight Each (kg.)	S-421TW Wedge Only Stock No.	Wedge Only Weight Each (kg.)	API 2C S-421TW Wedge Only Stock No.	Optional G-4082 API 2C Bolt, Nut & Cotter		Optional G-4082 Bolt, Nut & Cotter	
								G-4082 API 2C Stock No.	Weight Each (kg)	G-4082 Stock No.	Weight Each (kg)
9-10	3/8	1035000	1035005	1.44	1035555	.23	1092230	1092230	.17	1092227	.17
11-13	1/2	1035009	1035014	2.79	1035564	.48	1092248	1092248	.31	1092236	.31
14-16	5/8	1035018	1035023	4.40	1035573	.81	1092257	1092257	.52	1092254	.52
18-19	3/4	1035027	1035032	6.58	1035582	1.18	1092293	1092293	.86	1092281	.86
20-22	7/8	1035036	1035041	9.75	1035591	1.82	1092319	1092319	1.46	1092307	1.46
24-26	1	1035045	1035050	13.9	1035600	2.44	1092337	1092337	2.44	1092325	2.44
28	1-1/8	1035054	1035059	20.5	1035609	3.56	1092364	1092364	3.40	1092343	3.40
30-32	1-1/4	1035063	1035068	29.4	1035618	4.80	1092375	1092375	4.70	1092372	4.70

Wire Rope Dia.		S-421T Stock No.	API 2C S-421T Stock No.	Dimensions (mm)														
				A	B	C +/- 2.29	D	G	H	J*	K*	L	P	R	S	T	U	V
9-10	3/8	1035000	1035005	145	69.1	20.6	20.6	35.1	77.7	198	47.8	22.4	39.6	11.2	54.1	11.2	31.8	35.1
11-13	1/2	1035009	1035014	175	88.1	25.4	25.4	41.1	95.5	226	32.0	26.9	49.3	12.7	65.0	13.5	44.5	47.8
14-16	5/8	1035018	1035023	210	109	31.8	30.2	53.8	114	273	50.5	31.0	57.2	14.2	82.6	17.5	51.0	55.5
18-19	3/4	1035027	1035032	251	130	38.1	35.1	62.0	134	314	61.2	35.6	66.8	16.8	92.2	19.8	59.5	65.0
20-22	7/8	1035036	1035041	286	149	44.5	41.4	68.5	156	365	63.0	42.4	79.5	19.1	109	22.4	68.5	74.5
24-26	1	1035045	1035050	325	161	51.0	51.0	74.7	177	414	77.2	51.0	95.5	22.4	119	26.2	73.0	83.5
28	1-1/8	1035054	1035059	365	176	57.0	57.0	84.0	194	466	65.0	57.0	108	25.4	138	27.9	82.6	90.5
30-32	1-1/4	1035063	1035068	415	222	66.5	63.5	90.5	239	520	74.7	59.5	114	26.9	156	30.2	117	125

\* Nominal NOTE: For intermediate wire rope sizes, use next larger size socket. The S-423T Super TERMINATOR wedge is designed to be assembled only into the Crosby S-421T TERMINATOR socket body. IMPORTANT: The S-423TW for sizes 14mm through 28mm will fit respective size standard Crosby S-421T basket. The 30-32mm S-423TW will only fit the Crosby S-421T 30-32mm basket marked with TERMINATOR.



# US-422T Utility Wedge Sockets



## US-422T

Most sizes now incorporate the Crosby TERMINATOR design and may vary in shape from above product shown.

- Basket is cast steel and individually magnetic particle inspected.
- Wedge socket terminations have an efficiency rating of 80% based on the catalog strength of XXIP wire rope.
- Wedges are color coded for easy identification.
  - Blue - largest wire line size for socket.
  - Black - mid size wire line for socket.
    - 11mm on US4
    - 14mm on US5
  - Orange - smallest wire line size for socket.
- Cast into each socket is the name "McKissick", "Crosby" or "CG", its model number and its wire line range.
- By simply changing out the wedge, each socket can be utilized for various wire line sizes (Ensure correct wedge is used for wire rope size).
- Cast into each wedge is the model number of the socket and the wire line size for which the wedge is to be used.
- Load pin is forged and headed on one end.
- Incorporates Crosby's patented QUIC-CHECK® "Go" and "No-Go" feature cast into the wedge. The proper size rope is determined when the following criteria are met:
  - 1) The wire rope should pass thru the "Go" hole in the wedge.
  - 2) The wire rope should NOT pass thru the "No-Go" hole in the wedge.
- US-422T wedge sockets contain a hammer pad (lip) to assist in proper securement of termination.
- Meets or exceeds all requirements of ASME B30.26 including identification, ductility, design factor, proof load and temperature requirements. Importantly, these sockets meet other critical performance requirements including fatigue life, impact properties and material traceability, not addressed by ASME B30.26.
- UWO-422T Wedges are to be used only with the US-422T Wedge Socket Assemblies.

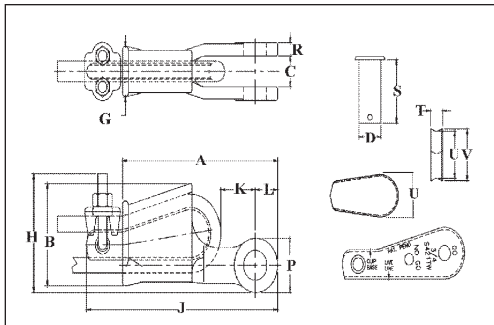

Scan this QR code with your smart device to view our Terminator video.



**SEE APPLICATION AND WARNING INFORMATION**  
 Page 58  
 Para Español: [www.thecrosbygroup.com](http://www.thecrosbygroup.com)

## US-422T UTILITY WEDGE SOCKETS

Model No.	Wire Rope Size		US-422T Stock No.	API 2C US-422T Stock No.	Weight Each (kg)	Wedge Only Stock No.	Weight Each (kg)	Dimensions (mm)														
	(mm)	(in.)						A	B	C +/- 2.29	D	G	H	J	K	L	P	R	S	T	U	V
US4T	10	3/8	1044300	1044305	2.09	1047310	.27	173	90.2	25.4	25.4	41.4	71.4	214	35.1	26.9	49.3	12.7	64.3	11.2	48.5	54.4
US4T	11	7/16	1044309	1044314	2.09	1047301	.27	173	90.2	25.4	25.4	41.4	71.4	222	27.4	26.9	49.3	12.7	64.3	13.5	44.7	47.8
US4T	13	1/2	1044318	1044323	2.09	1047329	.27	173	90.2	25.4	25.4	41.4	71.4	222	25.9	26.9	49.3	12.7	64.3	13.5	44.7	47.8
US5T	13	1/2	1044327	1044332	3.86	1047338	.45	233	107	35.8	31.8	54.1	84.1	284	46.7	38.1	76.2	16.0	82.6	19.1	48.8	54.9
US5T	14	9/16	1044336	1044341	3.86	1047347	.45	233	107	35.8	31.8	54.1	84.1	291	61.0	38.1	76.2	16.0	82.6	17.5	50.8	55.4
US5T	16	5/8	1044345	1044350	3.86	1047356	.45	233	107	35.8	31.8	54.1	84.1	291	59.4	38.1	76.2	16.0	82.6	17.5	50.8	55.4
US6T	16	5/8	1044354	1044359	4.26	1047365	.64	240	119	38.1	31.8	56.9	92.2	303	63.0	38.1	76.2	14.2	82.6	22.4	60.5	69.9
US6T	19	3/4	1044363	1044368	4.26	1047374	.64	240	119	38.1	31.8	56.9	92.2	300	51.6	38.1	76.2	14.2	82.6	22.4	54.1	66.8
US8AT	16	5/8	1044372	1044377	9.0	1047383	1.9	269	144	46.0	41.4	60.5	140	335	48.5	38.9	73.2	19.1	105	17.5	82.8	88.9
US8AT	19	3/4	1044381	1044386	9.3	1047392	2.2	269	144	46.0	41.4	60.5	148	344	60.5	38.9	73.2	19.1	105	19.8	79.2	85.9
US7*	22	7/8	1038580	—	7.48	1046674	1.18	286	130	33.3	31.8	68.3	—	—	65.0	41.4	82.8	16.8	82.6	26.9	53.8	65.0
US7*	25	1	1038589	—	7.48	1046683	1.18	286	130	33.3	31.8	68.3	—	—	65.0	41.4	82.8	16.8	82.6	26.9	47.8	60.5
US8T	22	7/8	1044404	1044409	14.3	1047425	3.4	324	177	46.0	41.4	77.7	183	407	72.9	41.9	79.2	19.1	105	22.4	98.6	106
US8T	25	1	1044417	1044422	14.7	1047431	3.9	324	177	46.0	41.4	77.7	186	417	58.9	41.9	79.2	19.1	105	26.2	95.5	103
US10T	28	1-1/8	1044426	1044431	25.1	1047440	5.7	405	219	46.0	41.4	90.7	232	501	82.8	55.6	111	19.1	105	27.7	121	129
US10T	32	1-1/4	1044435	1044440	26.3	1047459	6.8	405	219	46.0	41.4	90.7	239	514	71.9	55.6	111	19.1	105	30.2	117	125
US11T	28	1-1/8	1044444	1044449	27.5	1047468	5.7	415	222	66.5	63.5	90.4	232	507	85.6	59.4	114	26.9	156	27.7	121	129
US11T	32	1-1/4	1044453	1044458	29.4	1047477	6.8	415	222	66.5	63.5	90.4	239	520	74.7	59.4	114	26.9	156	30.2	117	125

\* Non-TERMINATOR Style

WIRE ROPE END FITTINGS

The Crosby S-423T Super TERMINATOR is the first wedge socket designed to take advantage of the performance properties associated with high performance, high strength, compacted strand, rotation resistant wire rope.

**The Crosby Super TERMINATOR offers several advantages over traditional methods of wedge socket terminations:**

- The innovative design will significantly increase the termination efficiency over existing wedge sockets available today.
- Terminations on most ropes have a minimum efficiency rating of 80% of the rope's catalog breaking strength.
- Design eliminates the difficulty of properly seating the wedge with high performance, high strength, compacted strand, rotation resistant wire rope into a wedge socket termination.
- Proper application of the Super TERMINATOR eliminates the "first load" requirement of conventional wedge socket terminations.
- US Patent 8,375,527 B1.

**Additional Features:**

- Wire rope sizes available: 5/8" -1 1/4", 14mm- 32mm
- Available as a complete assembly, or as a wedge kit that can be retrofitted onto existing Crosby S-421T TERMINATOR wedge sockets.
- Wedge accessories provided with a zinc finish.
- Meets or exceeds all ASME B30.26 requirements including: identification, ductility, design factor, proof load, and temperature requirements. Importantly, they meet other critical performance criteria not addressed by ASME B30.26 including: fatigue life, impact properties and material traceability.
- Available with bolt, nut and cotter (S-423TB)

**The Super TERMINATOR by Crosby.  
The first wedge socket termination  
designed specifically for high  
performance wire rope.**



Scan this QR code with your smart device to view our Super Terminator video.

**Crosby**<sup>®</sup> [www.thecrosbygroup.com](http://www.thecrosbygroup.com)

**S-423T  
Super  
Terminator**





# S-423T Super Terminator™



## S-423T

Wedge sockets meet the performance requirements of Federal Specification RR-S-550E, Type C, except those provisions required of the contractor. Meets the performance requirements of EN13411-6:2003. For additional information, see page 474 of General Catalog.

- The 423T wedge socket terminations have a minimum efficiency rating on most high performance, high strength, compacted strand, rotation resistant wire ropes of 80% based on the catalog breaking strength of the various ropes.\*\*
- Design eliminates the difficulty of properly seating the wedge with high performance wire rope into a wedge socket termination.
- Proper application of the Super TERMINATOR eliminates the "first load" requirement of conventional wedge socket terminations.
- S-423TW Wedge Kit can be retrofitted onto existing Crosby S-421T TERMINATOR wedge sockets.
- Wedge and accessories provided with a zinc finish.
- Meets the performance requirements of EN13411-6:2003.
- Meets or exceeds all requirements of ASME B30.26 including identification, ductility, design factor, proof load and temperature requirements. Importantly, these sockets meet other critical performance requirements including fatigue life, impact properties and material traceability, not addressed by ASME B30.26.
- US Patent 8,375,527 B1.
- Basket is cast steel and individually magnetic particle inspected.
- Pin diameter and jaw opening allows wedge and socket to be used in conjunction with closed swage and spelter sockets.
- Secures the tail or "dead end" of the wire rope to the wedge, thus eliminates loss or "punch out" of the wedge.
- Eliminates the need for an extra piece of rope, and is easily installed.
- The TERMINATOR® wedge eliminates the potential breaking off of the tail due to fatigue.
- The tail, which is secured by the base of the clip and the tension device, is left undeformed and available for reuse.
- **Available with Bolt, Nut, and Cotter Pin.**

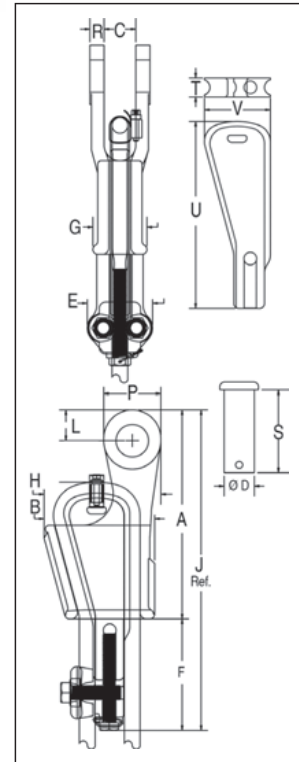

Scan this QR code with your smart device to view our Super Terminator video.



\*\* Due to the unique construction of various ropes, Crosby cannot make a broad general statement that all current and future design of ropes, when properly assembled with the Super TERMINATOR, will achieve a minimum 80% termination efficiency. Contact wire rope manufacturer or Crosby engineering (918-834-4611) to determine efficiency rating for a specific rope.



## S-423T WEDGE SOCKETS Assembly includes Socket, Wedge, Pin, Wire Rope Clip, Tensioner, Bolts and Secondary Retention Wire.

Wire Rope Dia.		S-423T Assembly with Round Pin and Cotter Pin				S-423TB Assembly with Bolt, Nut and Cotter Pin				S-423TW Wedge Kit			
		S-423T Stock No.	API 2C S-423T Stock No.	S-423T Weight Each		S-423TB Stock No.	API 2C S-423TB Stock No.	S-423TB Weight Each		S-423TW Stock No.	S-423TW Weight Each		
(in.)	(mm)			(lbs.)	(kg)			(lbs.)	(kg)		(lbs.)	(kg)	
5/8	14-16	1035123	1035128	12.7	5.8	1035218	1035223	13.1	5.9	1034018	5.2	2.4	
3/4	18-19	1035132	1035137	19.4	8.8	1035227	1035232	19.1	8.7	1034027	7.2	3.3	
7/8	20-22	1035141	1035146	28.8	13.1	1035236	1035241	27.8	12.6	1034036	10.3	4.7	
1	24-26	1035150	1035155	39.2	17.8	1035245	1035250	37.3	16.9	1034045	11.9	5.4	
1-1/8	28	1035169	1035174	57.1	25.9	1035254	1035259	57.9	25.9	1034054	19.9	9.0	
1-1/4	30-32	1035178	1035183	88.6	40.2	1035272	1035277	88.1	39.9	1034063	33.8	15.3	

\*\*Kit contains Wedge, Wire Rope Clip and Bolts, Tensioner Bolt and Secondary Retention Wire.

Wire Rope Dia.		S-423T Stock No.	Dimensions (mm)															
(mm)	(in.)		A	B	C	D	E	F	G	H	J*	L	P	R	S	T	U	V
14-16	5/8	1035123	210	114	31.8	30.2	76.2	103	54.1	117	313	31.0	57.2	14.2	82.6	19.1	175	66.0
18-19	3/4	1035132	251	132	38.1	35.1	82.6	122	62.0	136	373	35.6	66.5	16.8	92.2	22.4	194	76.7
20-22	7/8	1035141	286	149	44.5	41.4	96.8	146	68.3	156	431	42.4	79.5	19.1	109	25.4	241	88.1
24-26	1	1035150	325	167	50.8	50.8	96.8	146	74.7	179	471	51.1	95.3	22.4	119	28.7	264	97.0
28	1-1/8	1035169	365	176	57.2	57.2	102	174	85.9	198	539	57.4	108	25.4	138	31.8	300	107
30-32	1-1/4	1035178	415	219	66.5	63.5	114	197	90.7	238	612	59.4	114	26.9	168	35.1	352	148

\* Nominal NOTE: For intermediate wire rope sizes, use next larger size socket. The S-423T Super TERMINATOR wedge is designed to be assembled only into the Crosby S-421T TERMINATOR socket body. IMPORTANT: The S-423TW for sizes 14mm through 28mm will fit respective size standard Crosby S-421T basket. The 30-32mm S-423TW will only fit the Crosby S-421T 30-32mm basket marked with "TERMINATOR".

## Button Spelter Sockets



**SB-427**  
Button Spelter  
Socket

- Available in six sizes from 13mm - 38mm.
- Button Spelter terminations have a 100% efficiency rating, based on the catalog strength of the wire rope.
- Designed for use with mobile cranes. Can be used to terminate high performance, rotation resistant ropes, and standard 6 strand ropes.
- Easy to install assembly utilizes Crosby WIRELOCK® socketing compound.
- Sockets and buttons are re-usable.
- Replacement buttons and sockets are available.
- Locking feature available to prevent rotation of rope.
- Button contains cap with eye that can be attached to, and used to pull, rope during reeving process.
- Manufactured to the requirements of API-2C.

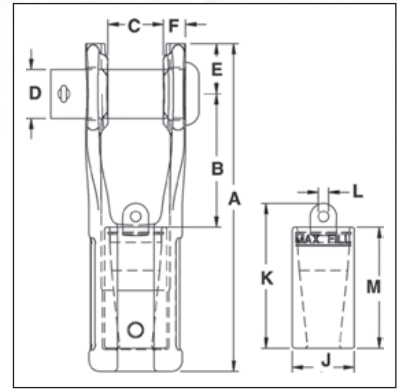

### SB-427 Button Spelter Sockets

Wire Rope Size		SB-427 Stock No.	Ultimate Load (t)	Weight Each (kg)	Socket Only Stock No.	Button Only Stock No.	Dimensions (mm)										Tolerance +/-
(mm)	(in.)						A	B	C	D	E	F	J	K	L	M	
13-16	1/2 - 5/8	1052005	27	2.76	1052107	1052309	202	82	33	30	31	14	38	89	6	74	1.52
16-19	5/8 - 3/4	1052014	45	4.67	1052116	1052318	240	99	39	35	37	17	44	109	10	87	1.52
19-22	3/4 - 7/8	1052023	57	7.75	1052125	1052327	275	112	45	41	43	19	52	121	10	101	1.52
22-26	7/8 - 1	1052032	82	13.24	1052134	1052336	327	139	52	51	51	23	62	143	16	115	2.29
28-32	1-1/8 - 1-1/4	1052041	136	20.86	1052143	1052345	378	144	64	57	64	28	75	180	19	145	2.29
35-38	1-3/8 - 1-1/2	1052050	161	35.38	1052152	1052354	459	182	77	70	70	31	92	205	19	172	2.29

### SB-427TB (Bolt, Nut and Cotter Pin)

Wire Rope Size		SB-427TB Stock No.	Ultimate Load (t)	Weight Each (kg)	Socket Only Stock No.	Button Only Stock No.	Dimensions (mm)										Tolerance +/-
(mm)	(in.)						A	B	C	D	E	F	J	K	L	M	
13-16	1/2 - 5/8	1052406	27	2.76	1052107	1052309	202	82	33	30	31	14	38	89	6	74	1.52
16-19	5/8 - 3/4	1052415	45	4.67	1052116	1052318	240	99	39	35	37	17	44	109	10	87	1.52
19-22	3/4 - 7/8	1052424	57	7.75	1052125	1052327	275	112	45	41	43	19	52	121	10	101	1.52
22-26	7/8 - 1	1052433	82	13.24	1052134	1052336	327	139	52	51	51	23	62	143	16	115	2.29
28-32	1-1/8 - 1-1/4	1052442	136	20.86	1052143	1052345	378	144	64	57	64	28	75	180	19	145	2.29
35-38	1-3/8 - 1-1/2	1052451	161	35.38	1052152	1052354	459	182	77	70	70	31	92	205	19	172	2.29

### Wirelock® Requirements

Wire Rope Size		WIRELOCK Required (cc)	WIRELOCK Stock No.	WIRELOCK® Kit Size (cc)
(mm)	(in.)			
13-16	1/2 - 5/8	35	1039602	100
16-19	5/8 - 3/4	60	1039602	100
19-22	3/4 - 7/8	100	1039602	100
22-26	7/8 - 1	140	1039602*	100
28-32	1-1/8 - 1-1/4	250	1039604	250
35-38	1-3/8 - 1-1/2	420	1039606	500

\* 2 kits required.



Scan this QR code with your smart device to view our Wedge and Button Sockets video.



# Mooring Spelter Sockets



**G-517  
Mooring  
Spelter Socket**

- Wide range of sizes available:
  - 32mm through 102mm Wireline
- “M-Line” socket terminations have a 100% efficiency rating, based on the catalog strength of the wire rope. Ratings are based on recommended use with 6 x 7, 6 x 19, or 6 x 37, IPS or XIP (EIP), XXIP (EEIP), RRL, FC, or IWRC wire rope. Strand constructed with minimal number of wires (e.g. 1 x 7) requires special consideration that socket basket length be five (5) times the strand diameter or fifty (50) times the wire diameter, whichever is the greater.
- Galvanized finish.
- Designed for today's higher strength classes of wire rope.
- Design of bail allows for easy connection to shackles and other connecting links.
- Socket design utilizes features to keep cone from rotating.
- Type approved and Certification in accordance with DNV's Rules for Certifications of Lifting Appliances, 2011 - DNV's Offshore Standard DNV-OS-E101, Drilling Plant, October 2009.

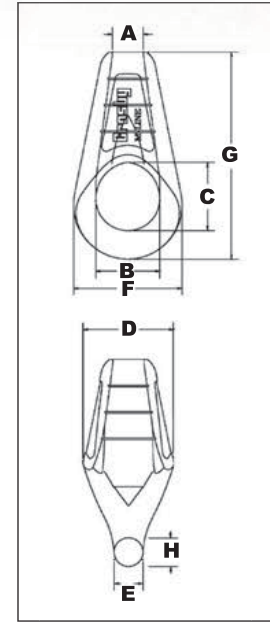

All Cast Mooring Sockets are Individually Magnetic Particle Inspected and Ultrasonic Inspected.



## G-517 “M-Line” Mooring Sockets

Wire Rope Size		Ultimate Load (t)	G-517 Stock No.	Weight Each (kg)	Dimensions (mm)							
(mm)	(in.)				A	B	C	D	E	F	G	H
32-35	1-1/4 - 1-3/8	113	1004943	7.7	41.4	78.5	92.2	113	36.6	130	277	38.9
38-41	1-1/2 - 1-5/8	136	1004961	13.6	49.5	93.7	110	138	40.6	160	330	46.0
44-48	1-3/4 - 1-7/8	181	1004989	19.5	56.6	106	115	160	46.7	183	358	53.1
50-54	2 - 2-1/8	227	1005002	25.9	63.5	121	134	178	53.1	210	407	56.9
57-60	2-1/4 - 2-3/8	277	1005020	34.5	70.6	133	146	196	58.7	233	455	66.6
64-67	2-1/2 - 2-5/8	363	1005048	48.1	77.5	149	170	217	68.3	257	505	67.6
70-73	2-3/4 - 2-7/8	454	1005066	62.6	84.6	165	181	237	76.2	282	549	63.0
76-79	3 - 3-1/8	544	1005084	87.5	89.9	184	197	262	82.6	313	597	82.3
82-86	3-1/4 - 3-3/8	635	1005105	104	96.8	194	224	278	88.9	334	654	87.1
88-92	3-1/2 - 3-5/8	735	1005123	127	105	203	230	298	93.7	355	703	105
95-102	3-3/4 - 4	907	1005141	174	112	222	267	328	93.7	403	765	113

WIRE ROPE END FITTINGS

# Open Spelter Sockets



**G-416 / S-416**

Open Grooved Sockets meet the performance requirements of Federal Specification RR-S-550E, Type A, except for those provisions required of the contractor. For additional information, see page 452.

- Forged Steel Sockets through 38mm, cast alloy steel 40mm through 102mm.
- Spelter socket terminations have an efficiency rating of 100%, based on the catalog strength of wire rope.
- Ratings are based on recommended use with 6 x 7, 6 x 19, or 6 x 37, IPS or XIP (EIP), XXIP (EEIP), RRL, FC, or IWRC wire rope.
- Strand constructed with minimal number of wires (e.g. 1 x 7) requires special consideration that socket basket length be five (5) times the strand diameter or fifty (50) times the wire diameter, whichever is the greater.



**NOTICE: All cast steel sockets 40mm and larger are magnetic particle inspected and ultrasonic inspected. Proof testing available on special order.**

**Drawing illustrates one groove used on sockets 6mm through 18mm. Sizes 20mm through 38mm use 2 grooves. Sizes 40mm and larger use 3 grooves.**

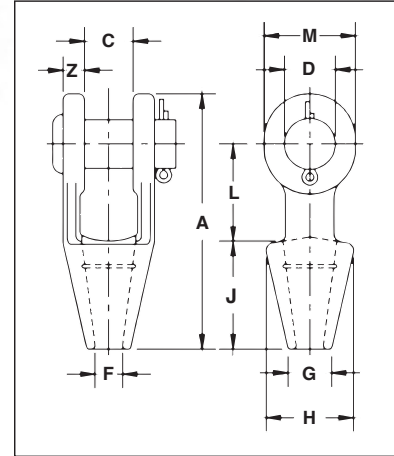

## G-416 / S-416 Open Spelter Sockets

Rope Dia.		Structural Strand Dia. (mm)	Ultimate Load (t)	Stock No.		Weight Each (kg)	Dimensions (mm)										Tolerance +/-
(mm)	(in.)			G-416 Galv.	S-416 S.C.		A	C	D	F	G	H	J	L	M	N	
6-7	1/4	-	4.50	1039619	1039628	.50	116	19.1	17.5	9.65	17.5	39.6	57.0	39.6	33.3	9.1	1.52
8-10	5/16-3/8	-	12.0	1039637	1039646	.59	123	20.6	20.6	12.7	20.6	42.9	57.0	44.5	38.1	11.2	1.52
11-13	7/16-1/2	-	20.0	1039655	1039664	1.02	141	25.4	25.4	14.2	23.9	47.8	63.5	51.0	47.8	12.7	1.52
14-16	9/16-5/8	12-13	27.0	1039673	1039682	1.63	171	31.8	30.2	17.5	28.7	57.0	76.0	63.5	57.0	14.2	1.52
18	3/4	14-16	43.0	1039691	1039708	2.64	202	38.1	35.1	20.6	31.8	66.5	89.0	76.0	66.5	15.7	1.52
20-22	7/8	18-19	55.0	1039717	1039726	4.38	235	44.5	41.4	23.9	38.1	82.5	102	89.0	79.5	20.3	1.52
24-26	1	20-22	78.0	1039735	1039744	7.03	268	51.0	51.0	28.7	44.5	95.5	114	102	95.5	22.4	1.52
28-30	1-1/8	24-26	92.0	1039753	1039762	9.75	300	57.0	57.0	31.8	51.0	105	127	117	105	25.4	3.05
32-35	1-1/4 - 1-3/8	28	136	1039771	1039780	14.1	335	63.5	63.5	38.1	57.0	121	140	127	121	28.7	3.05
38	1-1/2	30-32	170	1039799	1039806	21.4	384	76.0	70.0	41.4	70.0	133	152	152	137	30.2	3.05
* 40-42	* 1-5/8	33-35	188	1039815	1039824	24.9	413	76.0	76.0	44.5	76.0	140	165	165	146	33.3	3.05
* 44-48	* 1-3/4 - 1-7/8	36-40	268	1039833	1039842	37.2	464	89.0	89.0	51.0	79.5	162	191	178	165	39.6	3.05
* 50-54	* 2 - 2-1/8	42-45	291	1039851	1039860	59	546	102	95.5	57.0	95.5	187	216	229	178	46.0	3.05
* 56-60	* 2-1/4 - 2-3/8	46-48	360	1039879	1039888	76	597	114	108	63.5	102	210	229	254	197	54.0	3.05
* 64-67	* 2-1/2 - 2-5/8	50-54	424	1041633	1041642	114	648	127	121	73.0	114	235	248	274	216	60.5	3.05
* 70-73	* 2-3/4 - 2-7/8	56-62	511	1041651	1041660	143	692	133	127	79.0	124	267	279	279	229	73.0	6.35
* 75-80	* 3 - 3-1/8	64-67	563	1041679	1041688	172	737	146	133	86.0	133	282	305	287	241	76.0	6.35
* 82-86	* 3-1/4 - 3-3/8	70-73	722	1041697	1041704	197	784	159	140	92.0	146	302	330	300	254	79.0	6.35
* 88-92	* 3-1/2 - 3-5/8	76-80	779	1041713	1041722	255	845	171	152	98.5	165	314	356	318	274	82.5	6.35
* 94-102	* 3-3/4 - 4	-	875	1041731	1041740	355	921	191	178	108	184	346	381	343	318	89.0	6.35

\* Cast Alloy Steel. **NOTE: AVAILABLE WITH BOLT NUT AND COTTER. CONTACT CROSBY FOR MORE INFORMATION.**





# Closed Spelter Sockets



**G-417 / S-417**

Closed Grooved Sockets meet the performance requirements of Federal Specification RR-S-550E, Type A, except for those provisions required of the contractor. For additional information, see page 452.

- Forged Steel Sockets through 38mm, cast alloy steel 40mm through 102mm.
- Spelter socket terminations have an efficiency rating of 100%, based on the catalog strength of wire rope.
- Ratings are based on recommended use with 6 x 7, 6 x 19, or 6 x 37, IPS or XIP (EIP), XXIP (EEIP), RRL, FC, or IWRC wire rope.
- Strand constructed with minimal number of wires (e.g. 1 x 7) requires special consideration that socket basket length be five (5) times the strand diameter or fifty (50) times the wire diameter, whichever is the greater.



**NOTICE: All cast steel sockets 40mm and larger are magnetic particle inspected and ultrasonic inspected. Proof testing available on special order.**

**Drawing illustrates one groove used on sockets 6m through 18mm. Sizes 20mm through 38mm use 2 grooves. Sizes 40mm and larger use 3 grooves.**

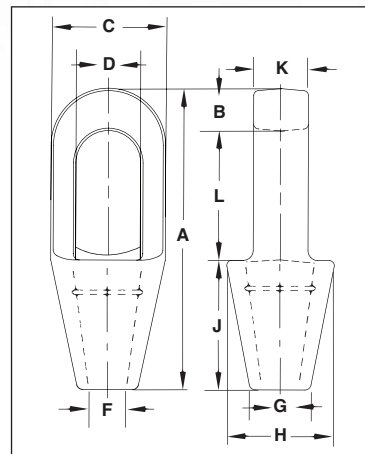

## G-417 / S-417 Closed Spelter Sockets

Rope Dia.		Structural Strand Dia. (mm)	Ultimate Load (t)	Stock No.		Weight Each (kg)	Dimensions (mm)									
(mm)	(in.)			G-417 Galv.	S-417 S.C.		A	B	C	D*	F	G	H	J	K	L
6-7	1/4	-	4.50	1039897	1039904	.23	116	12.7	39.6	22.4	9.65	17.5	39.6	57.2	12.7	46.0
8-10	5/16 - 3/8	-	12.0	1039913	1039922	.34	125	15.8	42.9	24.6	12.7	20.6	42.9	57.2	17.5	52.3
11-13	7/16 - 1/2	-	20.0	1039931	1039940	.68	140	17.5	51.0	29.5	14.2	23.9	51.0	63.5	22.4	58.7
14-16	9/16 - 5/8	12-13	30.8	1039959	1039968	1.13	162	20.6	67.0	35.8	17.5	30.2	67.0	76.2	25.4	65.0
18	3/4	14-16	43.5	1039977	1039986	1.92	194	26.9	76.2	42.2	22.4	33.3	70.0	89.0	31.8	77.7
20-22	7/8	18-19	65.3	1039995	1040000	3.28	226	33.3	92.0	49.3	25.4	38.1	82.5	102	38.1	90.5
24-26	1	20-22	81.6	1040019	1040028	4.76	254	36.6	105	58.5	28.7	44.5	95.5	114	44.5	103
28-30	1-1/8	24-26	100	1040037	1040046	6.46	283	39.6	114	65.0	31.8	51.0	105	127	51.0	116
32-35	1-1/4 - 1-3/8	28	136	1040055	1040064	8.95	309	41.4	127	71.0	38.1	58.5	119	138	56.5	129
38	1-1/2	30-32	170	1040073	1040082	13.24	355	49.3	137	81.0	41.4	70.5	132	151	62.5	155
† 40-42	† 1-5/8	33-35	188	1040091	1040108	16.32	390	54.0	146	82.5	44.5	76.2	140	165	70.0	171
† 44-48	† 1-3/4 - 1-7/8	36-40	268	1040117	1040126	25.96	445	55.5	171	95.5	51.0	79.5	162	191	76.2	198
† 50-54	† 2 - 2-1/8	42-45	309	1040135	1040144	35.83	505	62.0	194	111	57.2	95.5	187	216	82.5	224
† 56-60	† 2-1/4 - 2-3/8	46-48	360	1040153	1040162	47.62	546	70.0	216	127	66.8	105	210	229	92.0	248
† 64-67	† 2-1/2 - 2-5/8	50-54	424	1041759	1041768	63.50	597	79.5	241	140	74.5	114	235	248	102	270
† 70-73	† 2-3/4 - 2-7/8	56-62	549	1041777	1041786	99.79	645	79.5	273	159	79.5	124	259	279	124	286
† 75-80	† 3 - 3-1/8	64-67	656	1041795	1041802	125	689	85.6	292	171	86.0	133	292	305	133	298
† 82-86	† 3-1/4 - 3-3/8	70-73	750	1041811	1041820	142	743	102	311	184	92.0	146	311	330	146	311
† 88-92	† 3-1/2 - 3-5/8	76-80	820	1041839	1041848	181	787	102	330	197	98.5	160	330	356	159	330
† 94 - 102	† 3-3/4 - 4	-	1005	1041857	1041866	246	845	108	362	216	108	184	362	381	178	356

\* Diameter of pin must not exceed pin used on companion 416 socket. Reference adjacent page "D" dimension. † Cast Alloy Steel.



**S-505 Swaging Sleeve**

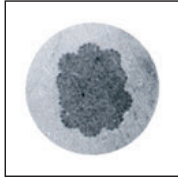

Cross Section of Swaged Sleeve



Scan this QR code with your smart device to view our QUIC-PASS Swaging System video.

- For Flemish eye wire rope splicing.
- Designed for low temperature toughness.
- Resists cracking when swaged (equals or exceeds stainless steel sleeves).
- Special processed low carbon steel.
- “COLD TUFF”® for better swageability.
- Sizes 6-7 through 37-38mm satisfy the type testing requirements for Flemish ferrule secured systems per EN 13411-3:2004 except those additional requirements defined for crane hoist rope.
- Can be stamped for identification after swaging without concern for fractures when following these directions.
  - Use round corner stamps to a maximum depth of 1.38mm. The area for stamping should be on the side of the sleeve in the plane of the sling eye, and no less than 7mm from either end of the sleeve.
- Standard Steel Sleeve terminations have efficiency ratings as follows based on the catalog strength of wire rope.

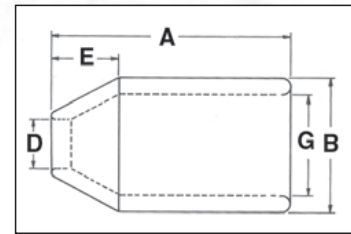

NOTE: See Page 45 for dimensional information.

S-505 Termination Efficiency		
Size (mm)	Type of Wire Rope *	
	IWRC	FC
6 - 26	96%	93%
28 - 52	92%	89%
56 and Larger	90%	87%



**\*\* NOTE:** S-505 Standard Sleeves are recommended for use with 6 x 19 or 6 x 37, IPS or XIP (EIP), XXIP (EEIP), RRL, FC or IWRC wire rope. Before using any National Swage fitting with any other type lay, construction or grade of wire rope, it is recommended that the termination be destructive and documented to prove the adequacy of the assembly to be manufactured.

## National QUIC-PASS® Swaging System

*“The Next Generation in Swaging Systems”*

### QUIC-PASS®

The **QUIC-PASS**® swaging system allows “Flemish style” wire rope terminations to be swaged in only two passes.

This is accomplished while maintaining currently published efficiency ratings and utilizing National Swage S-505 Standard “COLD TUFF”® Steel Sleeves.

- Allows the swaging process to be completed in just two passes. Resulting in a 50-75% reduction in the number of passes required with conventional swaging systems.
- Allows the dies to close completely with each pass, resulting in...
  - An increase in overall swaging process efficiencies (the job can be performed quicker).
  - A reduction in the complexity of swaging (the concern for excess flashing between dies has been eliminated).
  - A reduction in training time needed for operators (more user friendly).
- The finished sleeve has a “Hex” appearance that provides a QUIC-CHECK® look to determine if the termination has been swaged and provides a flat surface that allows for ease of I.D. stamping on the finished sleeve.

For additional swaging information, please refer to the Wire Rope End Terminations User’s Manual.



# National Steel Swaging Sleeves



## S-505 COLD TUFF® Standard Steel Sleeves

S-505 Standard Steel Sleeve Specifications											Swager / Die Data				
S-505 Stock No.	Rope Size		Weight Per 100 (kg)	Pkg. Qty.	Before Swage Dimensions (mm)					Maximum After Swage Dimensions (mm)		Standard Round Dies		QUIC-PASS Dies	
	(mm)	(in.)			A	B	D	E	G	Standard Die	QUIC-PASS Die	Die Description	Standard Die Stock No.	QUIC-PASS Die Stock No.	
1041063	6-7	1/4	3.60	250	25.4	16.8	7.88	7.12	11.9	14.5	14.4	1/4 Taper	1197528	1923530	
1041090	8	5/16	4.08	200	38.1	23.1	11.2	11.2	15.8	19.1	19.5	3/8 Taper	1192364	1923551	
1041107	9-10	3/8	5.44	100	38.1	23.1	11.9	9.91	16.8	19.1	19.5	3/8 Taper	1192364	1923551	
1041125	11	7/16	13.6	50	51.0	31.0	14.0	16.5	21.6	25.7	25.8	1/2 Taper	1192408	1923572	
1041143	13	1/2	13.2	50	51.0	31.0	16.0	14.2	23.1	25.7	25.8	1/2 Taper	1192408	1923572	
1041161	14	9/16	30.8	25	70.0	37.3	17.5	16.0	26.2	31.5	31.7	5/8 Taper	1192444	1923593	
1041189	16	5/8	25.9	25	70.0	37.3	19.1	16.0	27.7	31.5	31.7	5/8 Taper	1192444	1923593	
1041205	18-19	3/4	40.0	20	81.0	43.7	23.1	21.3	32.5	37.1	37.5	3/4 Taper	1192462	1923614	
1041223	22	7/8	62	10	90.5	51.5	26.2	25.4	38.9	42.7	44.1	7/8 Taper	1192480	1923635	
1041241	25-26	1	89	10	102	58.0	29.5	28.6	43.7	49.0	49.7	1 Taper	1192505	1923656	
1041269	28-29	1-1/8	118	Bulk	122	63.5	32.5	31.8	49.3	54.1	55.1	1-1/8 Open 1st Stage 2nd Stage	1192523 1192541	1923677	
1041287	31-32	1-1/4	154	Bulk	132	70.5	36.5	35.8	55.0	58.9	61.1	1-1/4 Open 1st Stage 2nd Stage	1192621 1192587	1923698	
1041303	34-35	1-3/8	195	Bulk	148	76.0	39.7	39.7	60.5	64.0	66.3	1-3/8 Open 1st Stage 2nd Stage	1192667 1192621	1923717	
1041321	37-38	1-1/2	226	Bulk	159	82.5	42.9	42.9	67.0	69.0	72.0	1-1/2 Open 1st Stage 2nd Stage	1192649 1192667	1923736	

## S-505 COLD TUFF® Standard Steel Sleeves

S-505 Standard Steel Sleeve Specifications											Swager / Die Data					
S-505 Stock No.	Rope Size		Weight Per 100 (kg)	Pkg. Qty.	Before Swage Dimensions (mm)					Maximum After Swage Dimensions (mm)	Die Description	Stock No.				
	(mm)	(in.)			A	B	D	E	G			500 Tons 1000 Tons 1500 Tons 5x7	Front Load		Side Load	
											1500 Ton 6x12	3000 Ton 6x12	1500 Ton 6x12	3000 Ton 6x12		
1041349	44-45	1-3/4	367	Bulk	184	97.5	49.2	50.0	79.5	78.7	1-3/4 Open 1st Stage 2nd Stage	1192685 1192701	—	—	—	—
1041367	50-52	2	510	Bulk	216	111	57.0	57.0	92.0	90.4	2 Open 1st Stage 2nd Stage	1192729 1192747	—	—	—	—
1041385	56-57	2-1/4	862	Bulk	243	128	63.5	64.5	102	105	2-1/4 Open 1st Stage 2nd Stage	1192765 1192783	1191089 1191043	1191089 1191043	—	1195085 1195067
1041401	62-64	2-1/2	1043	Bulk	267	140	70.0	71.5	114	114	2-1/2 Open 1st Stage 2nd Stage	—	1191061 1191089	1191061 1191089	1195370 1195469	1195076 1195085
1041429	68-70	2-3/4	1270	Bulk	292	146	76.0	78.5	121	119	2-3/4 Open 1st Stage 2nd Stage	—	1191034 1191052	1191034 1191052	1195389 1195478	1195094 1195101
1041447	75-76	3	1334	Bulk	305	152	82.5	86.0	127	126	3 Open 1st Stage 2nd Stage	—	1193201 1193229	1193201 1193229	1195398 1195487	1195110 1195129
1041483	87-89	3-1/2	2105	Bulk	356	178	98.5	100	148	147	3-1/2 Open 1st Stage 2nd Stage	—	1193247 1193265	1193247 1193265	—	1195138 1195147
1041492	93-95	3-3/4	2495	Bulk	381	191	103	108	160	158	3-3/4 Open 1st Stage 2nd Stage	—	—	1191114 1191132	—	1195263 1195272
1041508	100-105	4	3130	Bulk	406	206	111	114	173	170	4 Open 1st Stage 2nd Stage	—	—	1191150 1191178	—	1195156 1195165
1041526	112-114	4-1/2	4536	Bulk	457	232	124	129	195	189	4-1/2 Open 1st Stage 2nd Stage	—	—	1191187 1191203	—	1195174 1195183

WIRE ROPE END FITTINGS

**Intermediate Metric Die Chart**

Sleeve and Swaging Die Requirements for Intermediate Sizes of Metric Wire Rope							
S-505 Stock No.	S-505 Sleeve Size	Metric Wire Rope Size	Standard Round Dies				Maximum After Swage Dimension (mm)
			1st Stage Die		2nd Stage Die		
1041143	1/2	12	1190881	5 x 7 Double Cavity	—		25.1
1041223	7/8	20	1190901	5 x 7 Double Cavity	—		41.1
1041241	1	24	1190921	5 x 7 Double Cavity	—		47.8
1041321	1-1/2	36	1192649	5 x 7	1190941	5 x 7	66.8
1041349	1-3/4	40	1192685	5 x 7	1190961	5 x 7	74.9
1041367	2	48	1192729	5 x 7	1190971	5 x 7	87.9
1041401	2-1/2	60	1192809	5 x 7	1190981	5 x 7	111
1041401	2-1/2	60	1191061	6 x 12	1190991	6 x 12	111
1041487	3	72	1193201	6 x 12	1191001	6 x 12	122
1041483	3-1/2	80	1193247	6 x 12	1191101	6 x 12	138
1041483	3-1/2	84	1193247	6 x 12	1191121	6 x 12	141

*QUIC-PASS® system not available for these metric rope sizes.*



# Open Swage Sockets



**S-501  
Open Swage  
Sockets**

- Forged from special bar quality carbon steel, suitable for cold forming.
- Swage Socket terminations have an efficiency rating of 100% based on the catalog strength of wire rope.
- Hardness controlled by spheroidize annealing.
- Stamp for identification after swaging without concern for fractures (as per directions in Wire Rope End Terminations User's Manual).
- Swage sockets incorporate a reduced machined area of the shank which is equivalent to the proper "After Swage" dimension. Before swaging, this provides for an obvious visual difference in the shank diameter. After swaging, a uniform shank diameter is created allowing for a QUIC-CHECK® and permanent visual inspection opportunity.
- Designed to quickly determine whether the socket has been through the swaging operation and assist in field inspections, it does not eliminate the need to perform standard production inspections which include gauging for the proper "After Swage" dimensions or proof loading.

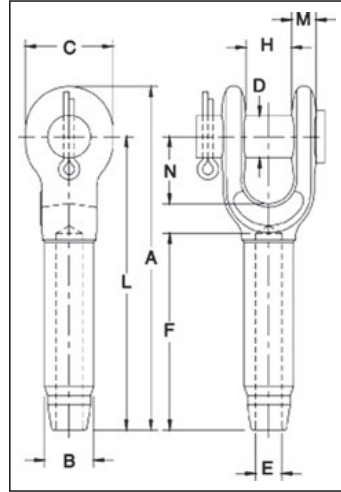

**NOTE: S-501 Swage Sockets are recommended for use with 6 x 19 or 6 x 37, IPS or XIP (EIP), XXIP (EEIP), RRL, FC or IWRC wire rope. Before using any National Swage fitting with any other type lay, construction or grade of wire rope, it is recommended that the termination be destructively tested and documented to prove the adequacy of the assembly to be manufactured. In accordance with ASME B30.9, all slings terminated with swage sockets shall be proof loaded.\***



## S-501 Open Swage Sockets

S-501 and S-501B Open Socket Specifications																	Swager / Die Data					
S-501 Stock No.	S-501B Stock No. †	Rope Size		Wt. Each (kg)	Ultimate Load** (t)	Before Swage Dimensions (mm)										Tolerance +/-	Max. After Swage Dim. (mm)	Die Description	Stock No.		Side Load	
		(mm)	(in.)			A	B	C	D	E	F	H	L	M	N				H	500 Ton 5 x 7	1500 Ton 6 x 12	1500 Ton 6 x 12
1039021	1054001	6	1/4	0.24	5.4	122	12.7	35.1	17.5	6.85	54.0	17.5	102	9.65	38.1	1.52	11.7	1/4 Socket	1192845	-	-	-
1039049	1054010	8	5/16	0.51	11.8	159	19.6	41.1	20.6	8.65	81.0	20.6	135	11.9	44.5	1.52	18.0	5/16-3/8 Socket	1192863	-	-	-
1039067	1054029	9-10	3/8	0.59	13.6	159	19.6	41.1	20.6	10.4	81.0	20.6	135	11.9	44.5	1.52	18.0	5/16-3/8 Socket	1192863	-	-	-
1039085	1054038	11-12	7/16	0.94	18.1	198	24.9	51.0	25.4	12.2	108	25.4	170	14.2	51.0	1.52	23.1	7/16-1/2 Socket	1192881	-	-	-
1039101	1054047	13	1/2	0.94	21.3	198	24.9	51.0	25.4	14.0	108	25.4	170	14.2	51.0	1.52	23.1	7/16-1/2 Socket	1192881	-	-	-
1039129	1054056	14	9/16	2.12	31.8	241	31.8	60.5	30.2	15.5	135	31.8	207	17.3	57.0	1.52	29.5	9/16-5/8 Socket	1192907	-	-	-
1039147	1054065	16	5/8	2.05	34.9	241	31.8	60.5	30.2	17.0	135	31.8	207	17.3	57.0	1.52	29.5	9/16-5/8 Socket	1192907	-	-	-
1039165	1054074	18-20	3/4	3.62	43.5	294	39.4	70.0	35.1	20.3	162	38.1	254	20.3	70.0	1.52	36.1	3/4 Socket	1192925	-	-	-
1039183	1054083	22	7/8	5.23	51.5	341	43.2	79.5	41.1	23.9	189	44.5	295	23.9	82.5	1.78	39.4	7/8 Socket	1192943	-	-	-
1039209	1054092	24-26	1	8.07	71.4	393	50.5	93.5	51.0	26.9	216	51.0	340	26.9	95.5	2.03	45.7	1 Socket	1192961	-	-	-
1039227	1054104	28	1-1/8	11.5	83.3	440	57.0	105	57.0	30.2	245	57.0	381	30.2	108	2.54	52.0	1-1/8 Socket	1192989	-	-	-
1039245	1054113	32	1-1/4	16.1	109	484	64.5	117	63.5	33.8	272	63.5	419	31.0	119	2.54	58.5	1-1/4 Socket	1193005	-	-	-
1039263	1054122	34-36	1-3/8	19.8	136	532	71.0	127	63.5	36.8	297	63.5	461	35.1	133	2.07	65.0	1-3/8 Socket	1193023	-	-	-
1039281	1054131	38-40	1-1/2	26.5	181	589	78.0	140	70.0	40.1	325	76.0	502	43.2	145	2.54	71.5	1-1/2 Socket	1193041	1191267	1195355	1195192
1039307	1054140	44	1-3/4	40.3	228	676	86.0	170	89.0	47.2	378	89.0	584	53.6	171	2.54	77.5	1-3/4 Socket	1193069	1191276	1195367	1195209
1042767	1054159	48-52	2	66	272	799	100	203	95.5	53.5	432	102	683	60.0	203	2.54	90.5	2 Socket	1193087	1191294	1195379	1195218

\*Maximum Proof Load shall not exceed 50% of XXIP rope catalog breaking strength. \*\* The Ultimate Loads of 18 mm through 32 mm sizes have been increased to meet the requirements for 8 strand 2160 Grade pendants. † Assembly with bolt, nut and cotter pin.

WIRE ROPE END FITTINGS

## Closed Swage Sockets



**S-502**  
Closed Swage  
Sockets

- Forged from special bar quality carbon steel, suitable for cold forming.
- Swage Socket terminations have an efficiency rating of 100% based on the catalog strength of wire rope.
- Hardness controlled by spheroidize annealing.
- Stamp for identification after swaging without concern for fractures (as per directions in Wire Rope End Terminations User's Manual).
- Swage sockets incorporate a reduced machined area of the shank which is equivalent to the proper "After Swage" dimension. Before swaging, this provides for an obvious visual difference in the shank diameter. After swaging, a uniform shank diameter is created allowing for a **QUIC-CHECK®** and permanent visual inspection opportunity.
- Designed to quickly determine whether the socket has been through the swaging operation and assist in field inspections, it does not eliminate the need to perform standard production inspections which include gauging for the proper "After Swage" dimensions or proof loading.

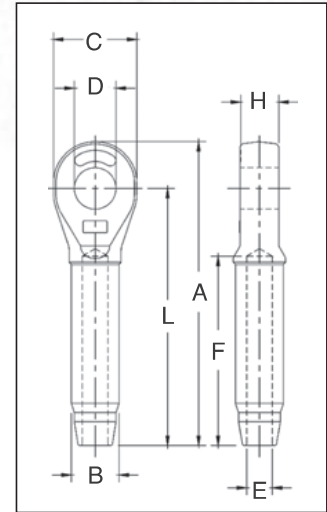

**NOTE:** S-502 Swage Sockets are recommended for use with 6 x 19 or 6 x 37, IPS or XIP (EIP), XXIP (EEIP), RRL, FC or IWRC wire rope. Before using any National Swage fitting with any other type lay, construction or grade of wire rope, it is recommended that the termination be destructively tested and documented to prove the adequacy of the assembly to be manufactured. In accordance with ASME B30.9, all slings terminated with swage sockets shall be proof loaded.\*



### S-502 Closed Swage Sockets

S-502 Closed Socket Specifications													Swager / Die Data					
S-502 Stock No.	Rope Size		Wt. Each (kg)	Ultimate Load** (t)	Before Swage Dimensions (mm)							Max. After Swage Dim. (mm)	Die Description	Stock No.		Side Load		
	(mm)	(in.)			A	B	C	D	E	F	H			L	500 Ton 5 x 7	1500 Ton 6 x 12	1500 Ton 6 x 12	3000 Ton 6 x 12
	1039325	6			1/4	.15	5.4	109	12.7	35.1	19.1			6.85	54.0	12.7	89.0	11.7
1039343	8	5/16	.34	11.8	138	19.6	41.1	22.4	8.65	81.0	17.0	114	18.0	5/16-3/8 Socket	1192863	-	-	-
1039361	9-10	3/8	.33	13.6	138	19.6	41.1	22.4	10.4	81.0	17.0	114	18.0	5/16-3/8 Socket	1192863	-	-	-
1039389	11-12	7/16	.64	18.1	176	24.9	51.0	26.9	12.2	108	21.8	146	23.1	7/16-1/2 Socket	1192881	-	-	-
1039405	13	1/2	.64	21.3	176	24.9	51.0	26.9	14.0	108	21.8	146	23.1	7/16-1/2 Socket	1192881	-	-	-
1039423	14	9/16	1.32	31.8	220	31.8	60.5	31.8	15.5	135	28.7	184	29.5	9/16-5/8 Socket	1192907	-	-	-
1039441	16	5/8	1.29	34.9	220	31.8	60.5	32.5	17.0	135	28.7	184	29.5	9/16-5/8 Socket	1192907	-	-	-
1039469	18-20	3/4	2.27	43.5	261	39.4	73.0	36.6	20.3	162	33.3	219	36.1	3/4 Socket	1192925	-	-	-
1039487	22	7/8	3.08	51.5	303	43.2	79.0	42.9	23.9	189	38.1	257	39.4	7/8 Socket	1192943	-	-	-
1039502	24-26	1	4.72	71.4	344	50.5	92.0	52.5	26.9	216	44.5	292	45.7	1 Socket	1192961	-	-	-
1039520	28	1-1/8	6.72	83.3	382	57.0	102	58.5	30.2	243	51.0	324	52.0	1-1/8 Socket	1192989	-	-	-
1039548	32	1-1/4	9.78	109	430	64.5	114	65.0	33.8	270	57.0	365	58.5	1-1/4 Socket	1193005	-	-	-
1039566	34-36	1-3/8	12.9	136	473	71.0	127	65.0	36.8	297	57.0	400	65.0	1-3/8 Socket	1193023	-	-	-
1039584	38-40	1-1/2	17.3	181	511	78.0	137	71.5	40.1	325	65.0	432	71.5	1-1/2 Socket	1193041	1191267	1195355	1195192
1039600	44	1-3/4	23.1	228	598	86.0	159	90.5	47.2	378	76.0	508	77.5	1-3/4 Socket	1193069	1191276	1195367	1195209
1042589	48-52	2	40.5	272	702	100	184	96.5	53.5	432	82.5	584	90.5	2 Socket	1193087	1191294	1195379	1195218

\* Maximum Proof Load shall not exceed 50% of XXIP rope catalog breaking strength. \*\*The Ultimate Loads of 18 mm through 32 mm sizes have been increased to meet the requirements for 8 strand 2160 Grade pendants.



# National Swage Buttons



**S-409  
Swage Buttons**

- Swage Button terminations have an efficiency rating of 98% based on the catalog strength of wire rope.
- Special processed, low carbon steel.
- COLD TUFF® for better swageability.
- Stamp for identification after swaging without concern for fractures (as per directions in the Wire Rope End Terminations User's Manual).

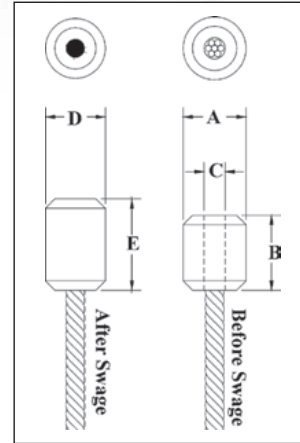

**NOTE:** S-409 Buttons are recommended for use with 6 x 19 or 6 x 37, IPS or XIP (EIP), RRL, FC or IWRC wire rope. Before using any National Swage fitting with any other type lay, construction or grade of wire rope, it is recommended that the termination be destructively tested and documented to prove the adequacy of the assembly to be manufactured.

## S-409 COLD TUFF® Buttons

S-409 Steel Swage Button Specifications										Swager / Die Data	
S-409 Stock No.	Size No.	Rope Size		Weight Per 100 (kg)	Before Swage Dimensions (mm)			After Swage Dimensions (mm)		Die Description	Stock No. 500 Tons 1000 Tons 1500 Tons 5 x 7
		(mm)	(in.)		A	B	C	D Maximum After Swage Dimensions	E Length*		
1040171	1 SB	3	1/8	.91	10.7	12.7	3.56	10.2	15.5	1/8 - 1/4 Button	1191621
1040215	3 SB	5	3/16	1.81	14.2	17.8	5.08	13.2	21.3	1/4 1st Stage	1197528
1040251	5 SB	6-7	1/4	3.63	17.3	26.9	7.87	14.7	33.5	1/8 - 1/4 Button	1191621
1040297	7 SB	8	5/16	7.26	22.4	28.7	9.14	19.6	33.8	3/8 1st Stage	1192364
1040313	8 SB	9-10	3/8	6.80	22.4	37.6	10.7	19.6	42.9	3/8 1st stage	1192364
1040331	9 SB	11	7/16	13.6	28.7	41.4	12.2	26.2	49.3	1/2 1st Stage	1192408
1040359	10 SB	13	1/2	22.7	33.3	48.0	14.0	29.5	55.1	5/8 Socket	1192907
1040377	11 SB	14	9/16	31.8	36.6	51.3	15.5	32.8	61.2	9/16 -5/8 Button	1191665
1040395	12 SB	16	5/8	45.4	39.6	61.5	17.0	36.1	73.4	3/4 Socket	1192925
1040411	13 SB	18-20	3/4	59	42.7	69.6	20.3	39.6	82.6	3/4 1st Stage	1192462
1040439	14 SB	22	7/8	100	50.8	83.1	23.9	45.7	98.0	7/8 1st Stage	1192480
1040457	15 SB	25-26	1	141	57.2	93.2	26.9	52.1	111	1 1st Stage	1192505
1040475	16 SB	28-29	1-1/8	204	65.0	103	30.2	58.4	122	1-1/8 1st Stage	1192523
1040493	17 SB	31-32	1-1/4	295	71.4	116	33.8	65.0	138	1-3/8 Socket	1193023

\* NOTE: Length is measured from outside end of termination.



**S-506 Duplex Sleeves**

- For turnback wire rope splicing.
- Special processed low carbon steel.
- Turnback terminations have efficiency ratings of 94% based on the catalog strength of wire rope.
- Designed for lower temperature toughness.
- Resists cracking when swaged (equals or exceeds stainless steel sleeves).
- COLD TUFF® for better swageability.
- Stamp for identification after swaging without concern for fractures (as per directions in the Wire Rope End Termination User's Manual).

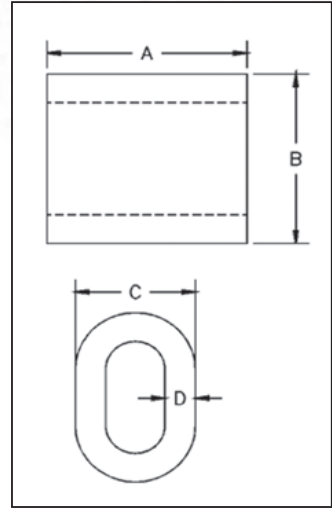

**NOTE:** S-506 Sleeves are recommended for use with 6 x 19 or 6 x 37, IPS or XIP (EIP), RRL, FC or IWRC wire rope. Before using any National Swage fitting with any other type lay, construction or grade of wire rope, it is recommended that the termination be destructive tested and documented to prove the adequacy of the assembly to be manufactured.

## S-506 COLD TUFF® Duplex Non-Tapered Sleeves

S-506 Steel Duplex Non-Tapered Sleeve Specifications										Swager / Die Data	
S-506 Stock No.	Rope Size		Weight Per 100 (kg)	Pkg. Qty.	Before Swage Dimensions (mm)				Max. After Swage Dimensions (mm)	Die Description	Stock No. 500 Tons 1000 Tons 1500 Tons 5 x 7
	(mm)	(in.)			A	B	C	D			
1039334	8	5/16	7.71	200	31.8	26.9	20.6	4.85	19.6	3/8 1st Stage	1192364
1039352	9-10	3/8	5.90	100	31.8	28.4	20.6	3.55	19.6	3/8 1st Stage	1192364
1039370	11	7/16	14.1	50	41.4	35.8	25.9	4.85	26.2	1/2 1st Stage	1192408
1039398	13	1/2	12.2	50	41.4	36.6	25.9	4.05	26.2	1/2 1st Stage	1192408
1039414	14	9/16	28.6	25	57.0	43.7	31.2	5.85	32.8	5/8 1st Stage	1192444
1039432	16	5/8	24.5	25	57.0	46.7	32.5	5.10	32.8	5/8 1st Stage	1192444
1039450	18-20	3/4	41.3	10	67.0	55.0	38.6	5.85	39.4	3/4 1st Stage	1192462
1039478	22	7/8	57	10	73.0	63.5	44.5	6.85	45.7	7/8 1st Stage	1192480
1039496	25-26	1	85	10	77.5	72.0	51.0	8.40	52.0	1 1st Stage	1192505
1039539	30-32	1-1/4	174	Bulk	103	89.0	63.5	9.65	65.0	1-3/8 Socket	1193023



# Shank Hooks For Swaging



**S-319SWG  
Shank Hook**

- Wide range of sizes available:
  - Working Load Limit: 0.4-14 Ton
  - Wire Rope sizes: 5mm through 30mm.
- Swage shank hook terminations have an efficiency rating of 95% based on the catalog strength of wire rope.
- Quenched and Tempered. Heat treat process allows for ease of swaging.
- Forged Carbon Steel.
- Design Factor of 5 to 1.
- Black Oxide finish on body (Shank is uncoated).
- Utilizes standard Crosby 319N shank hooks with interlocking hook tip. Each hook has a pre-drilled cam which can be equipped with a latch.
- Utilizes standard National Swage swaging dies.
- All hooks incorporate Crosby's patented **QUIC-CHECK®** markings (Angle Indicators and Throat Deformation Indicators). See page 113 for detailed information.

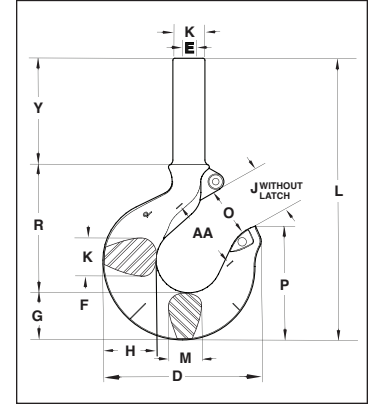

**NOTE:** For use with 6 X 19 or 6 X 37, IPS or XIP (EIP), XXIP (EEIP), RRL, FC, or IWRC wire rope. Before using any Crosby fitting with any other type lay, construction or grade of wire rope, it is recommended that the termination be destructively tested and documented to prove the adequacy of the assembly to be manufactured. Refer to swage socket or swage button instructions in the National Swage Swaging Products and Procedures Brochure for proper swaging techniques.

## S-319SWG Shank Hooks for Swaging

Wire Rope Size		Hook ID Code†	Working Load Limit (t)*	S-319SWG Stock No.	Weight Each (kg)	Required Swaging Die		Maximum After Swage Diameter (mm)
(mm)	(in.)					Die Description	Die Stock No.	
5	3/16	DC	0.4	1053002	.25	1/8" Button	1191621	10.2
6-7	1/4	FC	0.7	1053011	.35	1/4" Socket	1192845	11.7
8	5/16	GC	1.1	1053020	.57	1/4" Button	1191621	14.7
8	5/16	HC	1.1	1053039	.83	3/8" Socket	1192863	18.0
9-10	3/8	HC	1.6	1053048	.82	3/8" Socket	1192863	18.0
11	7/16	IC	2.1	1053057	1.65	1/2" Socket	1192881	23.1
12-13	1/2	IC	2.8	1053066	1.62	1/2" Socket	1192881	23.1
14-15	9/16	JC	3.5	1053075	3.34	5/8" Socket	1192907	29.5
16	5/8	JC	4.3	1053084	3.31	5/8" Socket	1192907	29.5
18	3/4	KC	6.2	1053093	5.77	3/4" Socket	1192925	36.1
20-22	7/8	LC	8.3	1053100	7.97	7/8" Socket	1192949	39.4
24-26	1	NC	11.0	1053119	14.3	1" Socket	1192961	45.7
28-30	1-1/8	OC **	14.0	1053128	24.4	1-1/8" Socket	1192989	52.1

\* Minimum Ultimate Load is 5 times the Working Load Limit. \*\* ID Code "O" is original 319 style hook. † See tables on pages 123 - 125 for correct latch per Hook ID Code.

Wire Rope Size		S-319SWG Stock No.	Dimensions (mm)														
(mm)	(in.)		B	D	E	F	G	H	J	K	L	M	O	P	R	Y	AA**
5	3/16	1053002	11.2	72.5	5.10	16.0	18.5	20.6	23.6	16.0	132	16.0	23.6	49.8	60.5	51.0	38.1
6-7	1/4	1053011	12.7	80.0	6.85	17.5	21.3	23.9	24.6	18.0	145	18.0	24.6	56.5	67.0	57.0	51.0
8	5/16	1053020	16.5	91.0	8.65	19.1	25.4	29.5	26.9	22.4	162	22.4	26.9	62.0	70.0	63.5	51.0
8	5/16	1053039	19.6	101	8.65	20.6	29.0	33.3	30.2	23.9	182	23.9	29.5	70.5	81.5	70.0	51.0
9-10	3/8	1053048	19.6	101	10.4	20.6	29.0	33.3	30.2	23.9	182	23.9	29.5	70.5	81.5	70.0	51.0
11	7/16	1053057	24.9	123	12.2	25.4	36.6	41.4	38.1	33.3	221	28.7	35.8	88.0	99.5	82.5	63.5
12-13	1/2	1053066	24.9	123	14.0	25.4	36.6	41.4	38.1	33.3	221	28.7	35.8	88.0	99.5	82.5	63.5
14-15	9/16	1053075	31.8	159	15.5	31.8	46.2	52.5	45.2	42.2	267	36.6	42.9	117	123	95.5	76.0
16	5/8	1053084	31.8	159	17.0	31.8	46.2	52.5	45.2	42.2	267	36.6	42.9	117	123	95.5	76.0
18	3/4	1053093	39.4	192	20.3	38.1	57.5	67.0	61.0	47.8	321	41.4	56.4	133	152	108	102
20-22	7/8	1053100	43.2	212	23.9	41.4	66.0	74.7	66.5	55.5	345	49.3	61.2	145	165	111	102
24-26	1	1053119	50.5	264	26.9	54.0	76.5	89.0	86.5	68.5	427	60.5	81.0	175	211	137	102
28-30	1-1/8	1053128	57.0	346	30.2	63.5	92.0	117	102	76.0	586	76.0	82.6	223	240	248	165

\*\* Deformation Indicators.

# Crosby®

## “The Standard” in Cell Tower Securment

When it comes to the securment of cell towers, Crosby® sets the industry standard with superior products, in-depth training, and time-tested expertise. For years, we have fulfilled the unique needs of each and every cell tower company that we've partnered with.



**Turnbuckle  
Fittings**



**Wire Rope  
End Fittings**





# National Hydraulic Swaging Machines



National offers the highest quality and most complete line of Hydraulic Swaging Machines specifically designed to be used to swage fittings on wire rope.

Three capacities to fit your requirements: 500 Tons • 1000 Tons • 1500 Tons



**1500 Ton Hydraulic Swaging Machines**

Approximate weight 15.6t. Overall height 2.6m. Fast advance and retract speed. Automatic slow, precision swaging speed.

The following features of National Hydraulic Swaging Machines offer a number of advantages for high production sling shops:

- A dual hydraulic system which combines the use of high speed and low pressure to bring dies into position; and the low speed and high pressure necessary for ideal swaging control.
- Adjustable tonnage control, so tonnage can be set to match die block Working Load Limit.
- Four column wide stance which provides the operator ample working clearance between columns and a large area for in-process sling storage.
- Vertical swage action which gives an equalized press on the fitting to produce uniform high quality.
- Self locating spring locks snap the shoe-type dies into place for quick set-up and change.
- The National four column wide stance Hydraulic Swaging Machines, each equipped with an up-acting ram, have two side cylinders for fast approach and return of the main ram. They come in three swaging capacities.
  - 500 Ton (4450 kN)
  - 1000 Ton (8900 kN)
  - 1500 Ton (13350 kN)



Scan this QR code with your smart device to view our National 4 Post Hydraulic Swaging Machine Video.

## Swaging Machine Capacity Chart for Swage, Sleeves, Ferrules and Buttons

Hydraulic Swaging Machine Size	Swaging Method	Die Size (mm)	Largest Fitting Allowed to be Swaged (mm)		
			S-505 Sleeve	S-506 Sleeve	S-409 Buttons
500 Ton	Full Die	63.5 x 127 Mark Series 102 x 178 127 x 178	38	32*	22
1000 Ton	Full Die	102 x 178 127 x 178	64	32*	32*
1500 Ton	Full Die	102 x 178 152 x 305	89	32*	32*

\* Largest size fitting available.

## Swaging Machine Capacity Chart for S-501 and S-502 Swage Sockets

Hydraulic Swaging Machine Size	Swaging Method	Die Size (mm)	Largest Fitting Allowed to be Swaged (mm)
500 Ton	Full Shank	63.5 x 127 Mark Series 102 x 178 127 x 178	19
	Progressive	102 x 178 127 x 178	32
1000 Ton	Full Shank	102 x 178 127 x 178	26
	Progressive	102 x 178 127 x 178	38
1500 Ton	Full Shank	102 x 178 152 x 305	32
	Progressive	102 x 178 152 x 305	52



**NOTE:** For special applications or conditions, contact Crosby National at (501) 982-3112.



WIRE ROPE END FITTINGS

**RESIN FOR SPELTER SOCKETS NOT AVAILABLE IN CANADA**

Note: For use on 416, 417, 427 and 517 spelter sockets only.



- 100% termination efficiency.
- Temperature operating range is -65° F to +240° F (-54°C to +116°C).
- Ideal for on-site applications.
- No hazardous molten metal.
- Improved fatigue life.
- Pouring temperature without booster pack is 48° F to 110° F (6.67°C to 43.3°C).
- One booster pack if pouring temperature is 35° F to 48° F (1.67°C to 8.89°C).
- Two booster packs if pouring temperature is 27° F to 35° F (-2.78°C to +1.67°C).
- Refer to Wire Rope End Terminations Manual for more information.



**APPROVALS:**

Lloyds Register of Shipping

Det Norske Veritas (DNV)

United States Coast Guard

Registro Italiano Navale

Germanischer Lloyd

United States Navy

American Bureau of Shipping

ISO 17.558

DNV-OS-E304

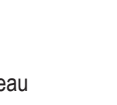

U.S. Department of Transportation  
United States Coast Guard



**NATO Numbers:**

- 100cc 8030-21-902-1823
- 250cc 8030-21-902-1824
- 500cc 8030-21-902-1825
- 1000cc 8030-21-902-1826

Witnessed and tested by American Bureau of Shipping. (ABS)

**Approximate U.S. Measurements:**

250cc's Kit 1 Cup

**WIRELOCK® W416-7 Socket Compound**

W416-7 Kits				Booster Pak Stock No.
Kit Size	Kit Per Case	Stock No.	Weight Each (kg)	
100	20	1039602	.28	1039603
250	12	1039604	.57	1039605
500	12	1039606	1.15	1039607
1000	12	1039608	2.08	1039609
2000	12	1039610	4.08	1039611

**Guide to amount WIRELOCK® Required**

Wire Rope Size		WIRELOCK® Required (cc)	Wire Rope Size		WIRELOCK® Required (cc)
(mm)	(in.)		(mm)	(in.)	
6-7	1/4	9	44	1-3/4	700
8	5/16	17	48	1-7/8	700
9-10	3/8	17	51	2	1265
11	7/16	35	54	2-1/8	1265
13	1/2	35	56	2-1/4	1410
14	9/16	52	60	2-3/8	1410
16	5/8	52	64	2-1/2	1830
20	3/4	86	67	2-5/8	1830
22	7/8	125	70	2-3/4	2250
26	1	160	76	3	3160
28	1-1/8	210	82	3-1/4	3795
32	1-1/4	350	88	3-1/2	4920
36	1-3/8	350	94	3-3/4	5980
40	1-1/2	420	102	4	7730
42	1-5/8	495	—	—	—

Wirelock is a hazardous material regulated by US DOT, ICAO/IATA and IMO for transportation.





# CROSBY® SPELTER BUTTON SB-427B

## APPLICATION INSTRUCTIONS



### Scope

This procedure is provided to give instructions for installation of wire rope into the Crosby® SB-427B Spelter Button using WIRELOCK® socketing material, or zinc socketing material. **Additionally, instructions regarding the reuse of spelter buttons are included.** The spelter button is part of a socket assembly that includes a socket basket, pin, cotter pin and button. If there are any questions regarding these instructions, please contact The Crosby Group LLC at (918) 834-4611 and request technical assistance.

NOTE: Many high performance ropes require special attention to prevent rope damage during cutting, seizing and brooming in preparation for the speltering operation. Attention to the special instructions is required to ensure proper termination efficiency. Consult rope manufacturer for specific details.

### Installation

Install button on the rope so that the live end of the rope extends out of small inside diameter of the button. Broomed end of rope should be pulled into button and placed completely to the "MAX FILL" line marked on the button to ensure correct length of engagement with socketing material.

### Socketing using WIRELOCK® Resin Material

Seizing, cleaning, brooming and preparation of wire rope and pouring of WIRELOCK® is to be carried out per instructions provided in the *Wire Rope End Terminations User's Manual*, and *WIRELOCK® Warnings and Application Instructions* located on the WIRELOCK® Product or in the Crosby General Catalog.

### Socketing Using Zinc Spelter Material

Seizing, cleaning, brooming and preparation of the wire rope, and pouring of zinc is to be carried out in accordance with recommendations of the *Wire Rope User's Manual* or other approved procedures.

Note: Before operation of the wire rope assembly, it is recommended that all poured sockets, whether with zinc or resin, be proof loaded to seat the cone.

### Reuse Of Crosby® Spelter Buttons

The following are general guidelines for the reuse of a Crosby® SB-427B Button. The use and inspection of used buttons are the responsibility of the user.

#### Procedure For Removing Spelter Cone

- Cut the rope close ( $\frac{1}{2}$ " ) to the nose end of the button and press the cone out of the button.
- For metallurgical, medical and environmental reasons, we do not recommend the use of heat to remove the spelter cone.
  - However, if this is the only means available for removing the zinc cone, care should be taken not to exceed 850°F (450°C) surface temperature. The preferred method would be a slow heat in a temperature controlled oven. If a torch (rosebud) is used, the heated area shall be monitored with a Tempil stick or a temperature indicator to prevent localized heating from exceeding the 850°F (450°C) limit.
  - To remove a WIRELOCK® cone, heat the surface of the button to 350°F (177°C) (do not exceed the 850°F (450°C) limit for any localized hot spot). Leave for 5-10 minutes, then drive the cone out with a hammer and drift.

#### Selection Of Buttons For Reuse

- Use only buttons that:
  - Do not show discoloration from excessive heating.
  - Do not show any signs of welding.
  - Select only buttons that have been cleaned and have passed a Magnetic Particle Inspection by a qualified technician (Level II ASNT-SNT-TC-1A-88) per ASTM E709. Acceptance criteria shall be per ASTM E125, Types II-VIII, Degree 1. No cracks are acceptable.
  - Select only buttons that do not show any signs of overloading or wear.
  - Select buttons that are free from nicks, gouges and abrasions. Indications may be repaired by lightly grinding until surfaces are smooth, provided they do not reduce the dimensions by more than 10% of the nominal catalog dimension.
  - Select buttons that are not distorted, bent or deformed.



**NOTE: Buttons having any of the indications as outlined above shall not be reused.**

# CROSBY® CLIPS

## WARNINGS & APPLICATION INSTRUCTIONS



**G-450**  
**(Red-U-Bolt®)**



**SS-450**  
**(316 Stainless Steel)**

### ⚠ WARNING

- Failure to read, understand, and follow these instructions may cause death or serious injury.
- Read and understand these instructions before using clips.
- Match the same size clip to the same size wire rope.
- Prepare wire rope end termination only as instructed.
- Do not use with plastic coated wire rope.
- Apply first load to test the assembly. This load should be of equal or greater weight than loads expected in use. Next, check and retighten nuts to recommended torque (See Table 1).

Efficiency ratings for wire rope end terminations are based upon the minimum breaking force of wire rope. The efficiency rating of a properly prepared loop or thimble-eye termination for clip sizes 32 mm through 22 mm is 80%, and for sizes 25.5 mm through 88.9 mm is 90%.

The number of clips shown (see Table 1) is based upon using RRL or RLL wire rope, 6 x 19 or 6 x 37 Class, FC or IWRC; IPS or XIP, XXIP. If Seale construction or similar large outer wire type construction in the 6 x 19 Class is to be used for sizes 1 inch and larger, add one additional clip. If a pulley (sheave) is used for turning back the wire rope, add one additional clip.

The number of clips shown also applies to rotation-resistant RRL wire rope, 8 x 19 Class, IPS, XIP, XXIP sizes 1-1/2 inch and smaller; and to rotation-resistant RLL wire rope, 19 x 7 Class, IPS, XIP, XXIP sizes 1-3/4 inch and smaller.

For other classes of wire rope not mentioned above, we recommend contacting Crosby Engineering to ensure the desired efficiency rating.

For elevator, personnel hoist, and scaffold applications, refer to ANSI A17.1 and ANSI A10.4. These standards do not recommend U-Bolt style wire rope clip terminations. The style wire rope termination used for any application is the obligation of the user.

**For OSHA (Construction) applications, see OSHA 1926.251.**

1. Refer to Table 1 following these instructions. Turn back specified amount of rope from thimble or loop.



Figure 1

Apply first clip one base width from dead end of rope. Apply U-Bolt over dead end of wire rope – live end rests in saddle (Never saddle a dead horse!). Use torque wrench to tighten nuts evenly, alternate from one nut to the other until reaching the recommended torque. (See Figure 1)

2. When two clips are required, apply the second clip as near the loop or thimble as possible. Use torque wrench to tighten



Figure 2

nuts evenly, alternating until reaching the recommended torque. When more than two clips are required, apply the second clip as near the loop or thimble as possible, turn nuts on second clip firmly, but do not tighten. (See Figure 2)

3. When three or more clips are required, space additional clips equally between first two – take up rope slack – use torque wrench to tighten nuts on each U-Bolt evenly, alternating from one nut to the other until reaching recommended torque. (See Figure 3)



Figure 3

4. If a pulley (sheave) is used in place of a thimble, add one additional clip. Clip spacing should be as shown. (See Figure 4)

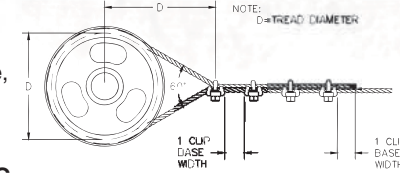

Figure 4

### 5. WIRE ROPE SPLICING PROCEDURES:

The preferred method of splicing two wire ropes together is to use inter-locking turnback eyes with thimbles using the recommended number of clips on each eye (See Figure 5).

An alternate method is to use twice the number of clips as used for a turnback termination. The rope ends are placed



Figure 5

parallel to each other, overlapping by twice the turnback amount shown in the application instructions. The minimum number of clips should be installed

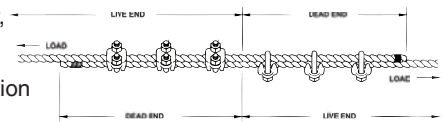

Figure 6

on each dead end (See Figure 6). Spacing, installation torque, and other instructions still apply.

### 6. IMPORTANT

Apply first load to test the assembly. This load should be of equal or greater weight than loads expected in use. Next, check and use torque wrench to retighten nuts to recommended torque. In accordance with good rigging and maintenance practices, the wire rope end termination should be inspected periodically for wear, abuse, and general adequacy.

Table 1

Clip Size/ Rope Size (in.)	(mm)	Minimum No. of Clips	Amount of Rope to Turn Back in mm	* Torque in Nm
1/8	3-4	2	85	6.1
3/16	5	2	95	10.2
1/4	6-7	2	120	20.3
5/16	8	2	133	40.7
3/8	9-10	2	165	61.0
7/16	11-12	2	178	68
1/2	13	3	292	88
9/16	14-15	3	305	129
5/8	16	3	305	129
3/4	18-20	4	460	176
7/8	22	4	480	305
1	24-25	5	660	305
1-1/8	28-30	6	860	305
1-1/4	33-34	7	1120	488
1-3/8	36	7	1120	488
1-1/2	38-40	8	1370	488
1-5/8	41-42	8	1470	583
1-3/4	44-46	8	1550	800
2	48-52	8	1800	1017
2-1/4	56-58	8	1850	1017
2-1/2	62-65	9	2130	1017
2-3/4	68-72	10	2540	1017
3	75-78	10	2690	1627
3-1/2	85-90	12	3780	1627

If a pulley (sheave) is used for turning back the wire rope, add one additional clip. See Figure 4.

If a greater number of clips are used than shown in the table, the amount of turnback should be increased proportionately.

\*The tightening torque values shown are based upon the threads being clean, dry, and free of lubrication.



# CROSBY® FIST GRIP® CLIPS

## WARNINGS & APPLICATION INSTRUCTIONS



**New Style Fist Grip®**  
3/16" - 5/8"



**Fist Grip® Clips**  
3/4" - 1-1/2"

### WARNING

- Failure to read, understand, and follow these instructions may cause death or serious injury.
- Read and understand these instructions before using clips.
- Match the same size clip to the same size wire rope.
- Do not mismatch Crosby clips with other manufacturer's clips.
- Prepare wire rope end termination only as instructed.
- Do not use with plastic coated wire rope.
- Apply first load to test the assembly. This load should be of equal or greater weight than loads expected in use. Next, check and retighten nuts to recommended torque (See Table 1).

Efficiency ratings for wire rope end terminations are based upon the minimum breaking force of wire rope. The efficiency rating of a properly prepared loop or thimble-eye termination for clip sizes 1/8" through 22mm is 80%, and for sizes 25.5mm through 88.9mm is 90%.

The number of clips shown (see Table 1) is based upon using RRL or RLL wire rope, 6 x 19 or 6 x 37 Class, FC or IWRC; IPS or XIP, XXIP. If Seale construction or similar large outer wire type construction in the 6 x 19 Class is to be used for sizes 1 inch and larger, add one additional clip. If a pulley (sheave) is used for turning back the wire rope, add one additional clip.

The number of clips shown also applies to rotation-resistant RRL wire rope, 8 x 19 Class, IPS, XIP, XXIP sizes 1-1/2 inch and smaller; and to rotation-resistant RRL wire rope, 19 x 7 Class, IPS, XIP, XXIP sizes 1-1/2 inch and smaller.

For other classes of wire rope not mentioned above, we recommend contacting Crosby Engineering at the address or telephone number on the back cover to ensure the desired efficiency rating.

The style of wire rope termination used for any application is the obligation of the user.

### For OSHA (Construction) applications, see OSHA 1926.251.

1. Refer to Table 1 in following these instructions. Turn back specified amount of rope from thimble or loop.



Figure 1

Apply first clip one base width from dead end of rope. Use torque wrench to tighten nuts evenly, alternating from one nut to the other until reaching the recommended torque. (See Figure 1)

2. When two clips are required, apply the second clip as near the loop or thimble as possible. Use torque



Figure 2

wrench to tighten nuts evenly, alternating until reaching the recommended torque. When more than two clips are required, apply the second clip as near the loop or thimble as possible, turn nuts on second clip firmly, but do not tighten. (See Figure 2)

3. When three or more clips are required, space additional clips equally between first two – take up rope slack – use torque wrench to tighten

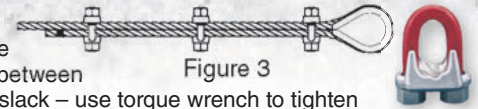

Figure 3

nuts on each clip evenly, alternating from one nut to the other until reaching recommended torque. (See Figure 3)

4. If a pulley (sheave) is used in place of a thimble, add one additional Fist Grip. Fist Grip spacing should be as shown. (See Figure 4)

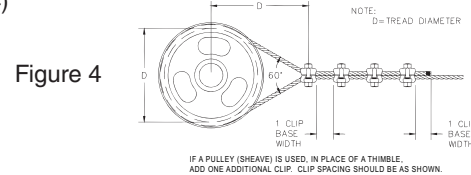

Figure 4

NOTE: D = TREAD DIAMETER  
IF A PULLEY (SHEAVE) IS USED, IN PLACE OF A THIMBLE, ADD ONE ADDITIONAL CLIP. CLIP SPACING SHOULD BE AS SHOWN.

### 5. WIRE ROPE SPLICING PROCEDURES:

The preferred method of splicing two wire ropes together is to use inter-locking turnback eyes with thimbles, using the recommended

number of clips on each eye (See Figure 5).



Figure 5

An alternate method is to use twice the number of clips as used for a turnback termination.

The rope ends are placed parallel to each other, overlapping by twice the turnback amount shown in the application

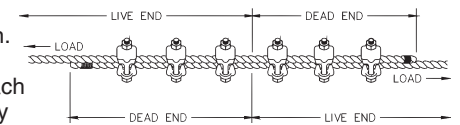

Figure 6

instructions. The minimum number of clips should be installed on each dead end (See Figure 6). Spacing, installation torque, and other instructions still apply.

### 6. IMPORTANT

Apply first load to test the assembly. This load should be of equal or greater weight than loads expected in use. Next, check and use torque wrench to retighten nuts to recommended torque.

In accordance with good rigging and maintenance practices, the wire rope end termination should be inspected periodically for wear, abuse, and general adequacy.

Table 1

Clip Size (in.)	Rope Size (mm)	Minimum No. of Clips	Amount of Rope to Turn Back in mm	* Torque in Nm
3/16	5	2	100	40.7
1/4	6-7	2	100	40.7
5/16	8	2	127	40.7
3/8	9-10	2	133	61.0
7/16	11-12	2	165	88.1
1/2	13	3	279	88.1
9/16	14-15	3	323	176
5/8	16	3	342	176
3/4	18-20	3	406	305
7/8	22	4	660	305
1	24-25	5	940	305
1-1/8	28-30	5	1040	488
1-1/4	32-34	6	1400	488
1-3/8	36	6	1400	488
1-1/2	38-40	7	1980	678

If a pulley (sheave) is used for turning back the wire rope, add one additional clip. See Figure 4.

If a greater number of clips are used than shown in the table, the amount of turnback should be increased proportionately.

\*The tightening torque values shown are based upon the threads being clean, dry, and free of lubrication.

# TERMINATOR™

## WARNINGS & APPLICATION INSTRUCTIONS

Extended Wedge Socket Assembly U.S. Patent No. 5,553,360 and Canada Patent No. 2,217,004

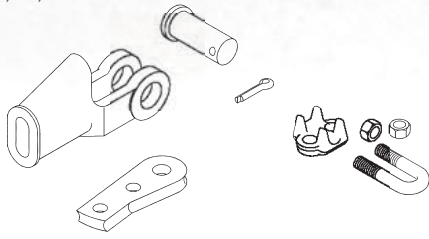

### S-421T / US-422T “TERMINATOR”

**NOTE:** The design of the basket for the S-421T 1-1/4” TERMINATOR Wedge Socket does not allow proper fit to the old style Crosby S-421W wedge (see Fig. 1). **Do not assemble or use.** The design of the basket for each US-422T TERMINATOR® Wedge Socket does not allow proper fit to the old style UWO-422 wedge (See Fig. 1). **Do not assemble or use.** All S-421T and US-422T TERMINATOR baskets are marked with a capital “T” or TERMINATOR.

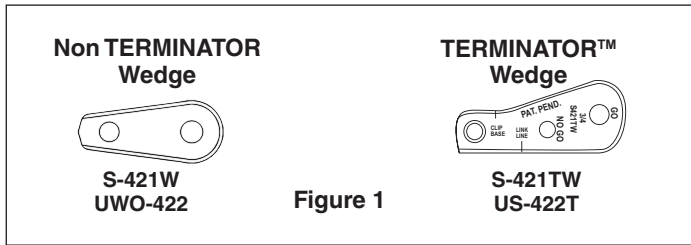

**QUIC-CHECK®** “Go” and “No-Go” features cast into wedge. The proper size wire rope determined when the following criteria are met:  
1. The wire rope shall pass thru the “Go” hole in the wedge.  
2. The wire rope shall NOT pass thru the “No-Go” hole in the wedge.



### Important Safety Information – Read and Follow Inspection/Maintenance Safety

- Always inspect socket, wedge and pin before using.
- Do not use part showing cracks.
- Do not use modified or substitute parts.
- Repair minor nicks or gouges to socket or pin by lightly grinding until surfaces are smooth. Do not reduce original dimension more than 10%. Do not repair by welding.
- Inspect permanent assemblies annually, or more often in severe operating conditions.
- Do not mix and match wedges or pins between models or sizes.
- Always select the proper wedge and socket for the wire rope size.

### Assembly Safety

- Use only with standard 6 to 8 strand wire rope of designated size. For intermediate size rope, use next larger size socket. For example: When using 9/16” diameter wire rope use a 5/8” size Wedge Socket Assembly. Welding of the tail on standard wire rope is not recommended. Seizing of the tail is preferred following the recommended practices of the wire rope manufacturer. The tail length of the dead end should be a minimum of 6 rope diameters but not less than 150 mm (See Figure 2).
- **To use with Rotation Resistant wire rope** (special wire rope constructions with 8 or more outer strands), ensure that the dead end is welded, brazed or seized before inserting the wire rope into the wedge socket to prevent core slippage or loss of rope lay. Seizing of the tail is preferred following the recommended practices of the wire rope manufacturer. The tail length of the dead end should be a minimum of 20 rope diameters but not less than 150 mm (See Figure 2).
- Properly match socket, wedge and clip (See Table 1) to wire rope size.

- Align live end of rope, with center line of pin.(See Figure 2)
- Secure dead end section of rope. (See Figure 2)
- Tighten nuts on clip to recommended torque. (See Table 1)
- Do not attach dead end to live end or install wedge backwards (See Fig. 3).
- Use a hammer to seat Wedge and Rope as deep into socket as possible before applying first load.

## WARNING

- **Loads may slip or fall if the Wedge Socket is not properly installed.**
- **Load misapplied in direct contact with the wedge can dislodge the wedge and cause loss of load.**
- **A falling load can seriously injure or kill.**
- **Read and understand these instructions before installing the Wedge Socket.**
- **Do not side load the Wedge Socket.**
- **Apply first load to fully seat the Wedge and Wire Rope in the socket. This load should be of equal or greater weight than loads expected in use.**
- **Do not interchange wedges between S-421T and US422T or between sizes.**
- **Do not assemble an old style 1-1/4” (30-32mm) S-421W wedge into an S-421T 1-1/4” (30-32mm) TERMINATOR basket.**
- **Do not assemble an old style UWO-422 wedge into a US-422T TERMINATOR basket.**

Figure 2

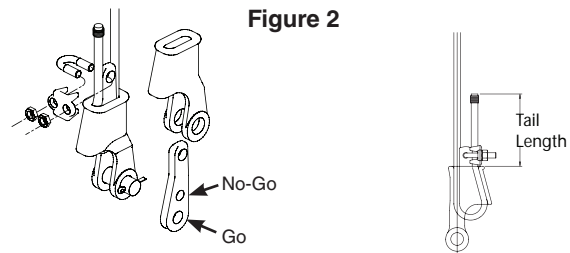

### \*Tail Length

Standard 6 to 8 Strand Wire Rope	Rotation Resistant Wire Rope
A minimum of 6 rope diameters, but not less than 150mm	A minimum of 20 rope diameters, but not less than 150mm

TABLE 1

Rope Size (mm)	9-10	11-13	14-16	18-19	20-22	24-26	28	32
Clip Size (in.)	3/8	1/2	5/8	3/4	7/8	1	1-1/8	1-1/4
* Torque Nm.	61	88	129	176	305	305	305	488

\* The tightening torque values shown are based upon the threads being clean, dry, and free of lubrication.

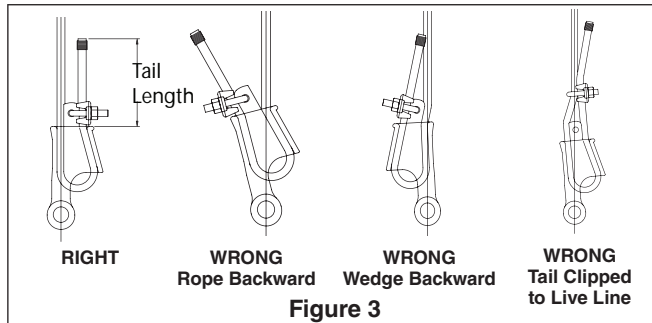

Figure 3

### Operating Safety

- Apply first load to fully seat the Wedge and Wire Rope in the socket. This load should be of equal or greater weight than loads expected in use.
- Efficiency rating of the Wedge Socket termination is based upon the catalog breaking strength of Wire Rope. The efficiency of a properly assembled Wedge Socket is 80%.
- During use, do not strike the dead end section or wedge with any other elements of the rigging (Called two blocking).
- Do not allow a direct load to contact the wedge.



# SUPER TERMINATOR™ WEDGE SOCKET

## WARNINGS & APPLICATION INSTRUCTIONS

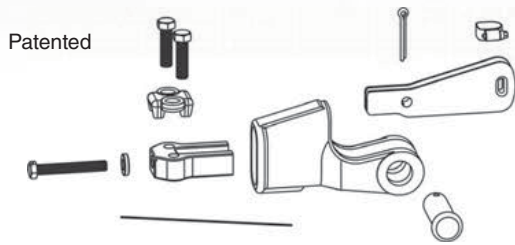

S-423T "SUPER TERMINATOR"

The intended purpose of the SUPER TERMINATOR is to offer a Wedge Socket termination, which when assembled properly with high performance, high strength, compacted strand, rotation resistant wire rope will achieve an 80% termination efficiency. Due to the unique construction of these ropes, Crosby cannot make a broad general statement that all current and future designed ropes, when properly assembled with a SUPER TERMINATOR, will achieve a minimum 80% termination efficiency. (To determine the efficiency rating for a specific rope, contact Crosby Engineering at 918-834-4611.)

The SUPER TERMINATOR may be purchased as a complete Wedge Socket assembly or the Wedge assembly may be purchased for retrofit onto your Crosby S-421TW wedge socket basket.

The Crosby S-423TW SUPER TERMINATOR Wedge is designed to be assembled only into the Crosby S-421T socket basket. For the 30-32mm S-423T, assemble only on to S-421T basket marked TERMINATOR.

### Important Safety Information - Read and Understand Inspection/Maintenance Safety

- Always inspect socket, wedge and pin before using.
- Do not use part showing cracks.
- Do not use modified or substitute parts.
- Repair minor nicks or gouges to socket or pin by lightly grinding until surfaces are smooth. Do not reduce original dimension more than 10%. Do not repair by welding.
- Inspect permanent assemblies annually, or more often in severe operating conditions.
- Do not mix and match wedges or pins between models or sizes.
- Always select the proper wedge and socket for the wire rope size.

### Assembly Safety

- Properly match socket and wedge assembly to wire rope size.
- Ensure the dead end is properly seized before inserting the wire rope into the wedge socket basket. High performance, high strength, compacted strand, rotation resistant wire ropes are sensitive to seizing methods. For specific seizing procedures, contact the wire rope manufacturer.
- The tail length of the dead end should be a minimum of 20 rope diameters but not less than 254mm (See Fig. 1).
- Mount wedge socket basket in vice.
- Insert live end of wire rope into wedge basket, aligning live end of rope with center line of pin. Make a loop and return. (See Figure 2).
- Pull on live line to remove excess out of loop, leaving enough room to properly insert wedge into basket. (See Figure 3).
- Secure rope to SUPER TERMINATOR Wedge with clamp (See Figure 4).
- Pull Wedge and rope into basket until tensioner bolt, with washers properly applied, can engage threads in nose of wedge. Auxillary power may be required to fully pull wedge and rope into basket. (See Figure 5).
- Use torque wrench to tighten tensioner bolt to recommended torque value, properly seating wedge and rope into basket. Reference Table 1 for recommended Torque in N-m.
- Secure dead end section of rope with clip base. Tighten bolts to recommended torque values (See Table 1).
- Properly install wire to securely lock tensioner bolt to tensioner. (See Figure 6).
- Do not attach dead end to live end or install wedge backwards. (See Figure 7).

### Operating Safety

- Proper application of the Super TERMINATOR eliminates the "first load" requirement of conventional wedge socket terminations.
- Efficiency rating of the Wedge Socket termination is based upon

the catalog breaking strength of Wire Rope. The efficiency of a properly assembled Super Terminator on most high performance, high strength, compacted strand, rotation resistant ropes will achieve 80% of catalog breaking strength of rope, depending on the unique construction of these ropes. (To determine the efficiency rating for a specific rope, contact Crosby Engineering at 918-834-4611.)

- During use, do not strike the dead end section or wedge with any other elements of the rigging (Called two blocking).
- The SUPER TERMINATOR wedge socket may also be used with standard 6 to 8 strand and rotation resistant wire rope (special wire rope constructions with 8 or more strands).
- Do not allow direct load to contact the wedge.

### WARNING

- Loads may slip or fall if the Wedge Socket is not properly installed.
- A falling load can seriously injure or kill.
- Load misapplied in direct contact with the wedge can dislodge the wedge and cause loss of load.
- Read and understand these instructions before installing the Wedge Socket.
- Do not side load the Wedge Socket.
- Apply recommended torque to tensioner and clip bolts, and properly install wire to securely lock tensioner bolt to tensioner.
- Do not assemble the S-423 Wedge in any brand or model socket basket other than the Crosby S-421T TERMINATOR.
- The size is marked on the socket basket and wedge, do not interchange wedge between sizes.

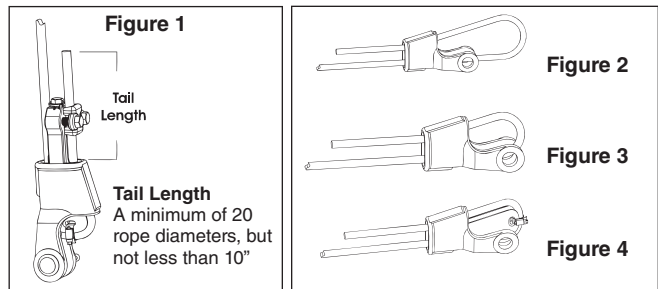

Wedge Size (mm)	Tensioner Bolt Torque Nm*	Clip Bolts Torque Nm*
15.9	149	129
19.1	203	176
22.2	515	305
25.4	515	305
28.6	814	305
31.8	1220	488

\* The tightening torque values shown are based upon the threads being clean, dry, and free of lubrication.

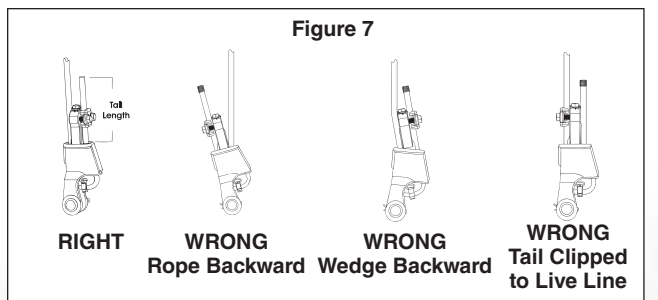
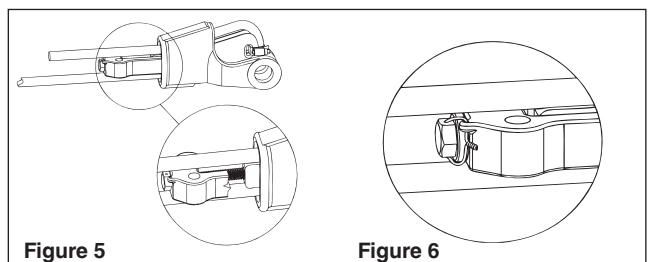

WIRE ROPE END FITTINGS

## WEDGE SOCKET

### WARNINGS & APPLICATION INSTRUCTIONS

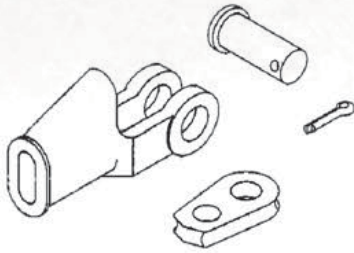

S-421 / US-422

#### Important Safety Information - Read and Follow Inspection/Maintenance Safety

- Always inspect socket, wedge and pin before using.
- Do not use part showing cracks.
- Do not modify or substitute parts.
- Repair minor nicks or gouges to socket or pin by lightly grinding until surface are smooth. Do not reduce original dimension more than 10%. Do not repair by welding.
- Inspect permanent assemblies annually, or more often in severe operating conditions.
- Do not mix and match wedges or pins between models or sizes.
- Always select the wedge and socket for the wire rope size.

#### Assembly Safety

- Use only with standard 6 to 8 strand wire rope of designated size. For intermediate size rope, use next larger size socket. For example: When using 14 mm diameter wire rope use a 16 mm size Wedge Socket Assembly. Welding of the tail on standard wire rope is not recommended. Seizing of the tail is preferred following the recommended practices of the wire rope manufacturer. The tail length of the dead end should be a minimum of 6 rope diameters but not less than 150 mm.
- Align live end of rope, with center line of pin. (See Figure 1)
- Secure dead end section of rope. (See Figure 1)
- DO NOT ATTACH DEAD END TO LIVE END. (See Figure 1)
- Use a hammer to seat Wedge and Rope as deep into socket as possible before applying first load.
- To use with Rotation Resistant wire rope (special wire rope constructions with 8 or more outer strands) ensure that the dead end is welded, brazed or seized before inserting the wire rope into wedge socket to prevent core slippage or loss of rope lay. The tail length of the dead end should be a minimum of 20 rope diameters but not less than 150mm. (Figure 1)

### ⚠ WARNING

- Loads may slip or fall if the Wedge Socket is not properly installed.
- Load misapplied in direct contact with the wedge can dislodge the wedge and cause loss of load.
- A falling load can seriously injure or kill.
- Read and understand these instructions before installing the Wedge Socket.
- Do not side load the Wedge Socket.
- Do not interchange Crosby wedge socket, wedge or pin with non Crosby Wedge socket, wedge or pin.
- Apply first load to fully seat the Wedge and Wire Rope in the socket. This load should be of equal or greater weight than loads expected in use.
- Do not interchange wedge between S-421 and US-422 or between sizes.

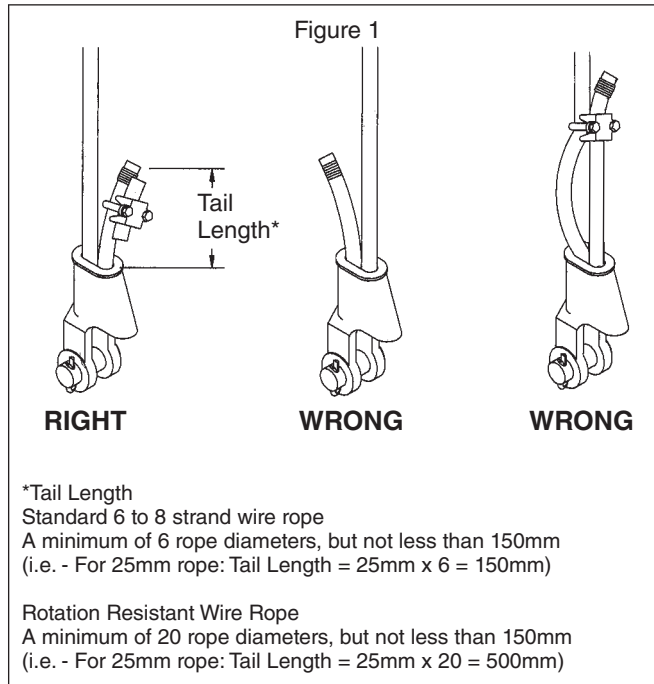

#### Operating Safety

- Apply first load to fully seat the Wedge and Wire Rope in the socket. This load should be of equal or greater weight than loads expected in use.
- Efficiency rating of the Wedge Socket termination is based upon the catalog breaking strength of Wire Rope. The efficiency of properly assembled Wedge Socket is 80%.
- During use, do not strike the dead end section with any other elements of the rigging (Called two-blocking).
- Do not allow a direct load to contact the wedge.

rev. 4



# CROSBY® SHANK HOOKS FOR SWAGING WARNINGS & APPLICATION INSTRUCTIONS

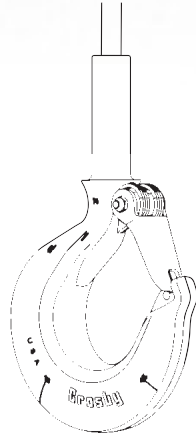

S-319SWG

- S-319SWG hooks are recommended for use with 6 x 19 or 6 x 37, IPS or XIP (EIP), XXIP (EEIP), RRL, FC or IWRC wire rope. Before using any National Swage fitting with any other type lay, construction of grade of wire rope, it is recommended that the termination be destructive tested and documented to prove the adequacy of the assembly to be manufactured.
- Use only Crosby shank hooks designed exclusively for swaging.
- A visual periodic inspection for cracks, nicks, wear gouges and deformation as part of a comprehensive documented inspection program should be conducted by trained personnel in compliance with the schedule in ANSI B30.10.
- For hooks used in frequent load cycles or pulsating loads, the hook should be periodically inspected by Magnetic particle or dye penetrant.
- Never use a hook whose throat opening has been increased, or whose tip has been bent more than 10 degrees out of plane from the hook body, or is in any other way distorted or bent.
- Note: A latch will not work properly on a hook with a bent or worn tip.
- Never use a hook that is worn beyond the limits shown in Figure 1.

- Remove from service any hook with a crack, nick, or gouge. Hooks with a nick or gouge shall be repaired by grinding lengthwise, following the contour of the hook, provided that the reduced dimension is within the limits shown in Figure 1. Contact Crosby Engineering to evaluate any crack.

**⚠ WARNING**

- Loads may disengage from hook if proper procedures are not followed.
- A falling load may cause serious injury or death.
- See OSHA Rule 1926.1431(g)(1)(i)(A) and 1926.1501(g)(4)(iv)(B) for personnel hoisting by cranes or derricks. A Crosby 319 hook with a PL Latch attached (when secured with bolt, nut and pin) may be used for lifting personnel. A Crosby S-319N hook with an S-4320 Latch attached (when secured with cotter pin or bolt, nut and pin) may be used for lifting personnel.
- Hook must always support the load. The load must never be supported by the latch.
- Never exceed the Working Load Limit (WLL) of the wire rope and hook system.
- Read and understand "National Swage Swaging Products and Procedures" manual before swaging the hook.

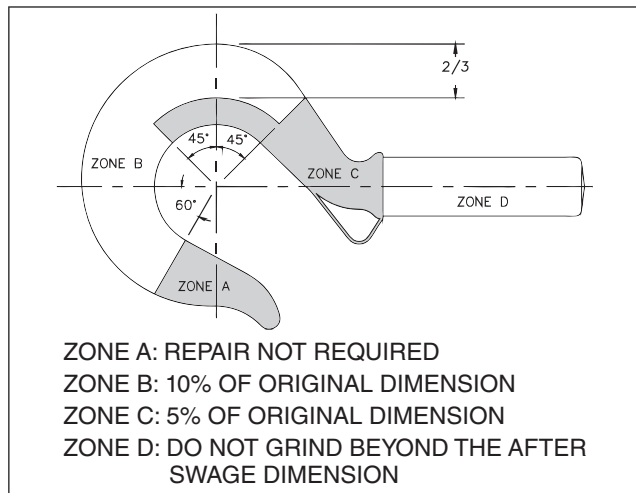
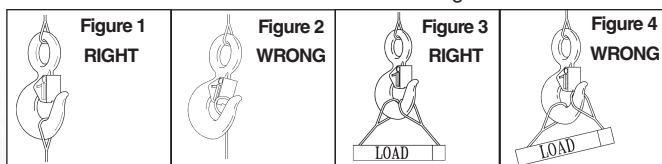

Figure 1

## Warning and Application Instructions For Crosby® Hook Latch Kit

### Important Safety Information – Read & Follow

- Always inspect hook and latch before using.
- Never use a latch that is distorted or bent.
- Always make sure spring will force the latch against the tip of the hook.
- Always make sure hook supports the load. The latch must never support the load. (See Figure 1 & 2)
- When placing two (2) sling legs in hooks, make sure the angle between the legs is less than 90° and if the hook or load is tilted, nothing bears against the bottom of this latch. (See Figures 3 & 4)
- Latches are intended to retain loose sling or devices under slack conditions.
- Latches are not intended to be an anti-fouling device.



**⚠ WARNING**

- Loads may disengage from hook if proper procedures are not followed.
- A falling load may cause serious injury or death.
- See OSHA Rule 1926.1431(g)(1)(i)(A) and 1926.1501(g)(4)(iv)(B) for personnel hoisting for cranes and derricks. Only a Crosby or McKissick hook with a PL Latch attached and secured with bolt, nut and cotter (or Crosby Toggle Pin) or a Crosby hook with a S-4320 Latch attached and secured with a cotter pin, or a Crosby SHUR-LOC® hook in the locked position may be used for any personnel hoisting. A hook with a Crosby SS-4055 latch attached shall NOT be used for personnel lifting.
- Hook must always support the load. The load must never be supported by the latch.
- Read and understand these instructions before using hook and latch.

**WIRE ROPE END FITTINGS**

- Never repair, alter, rework, or reshape a hook by welding, heating, burning, or bending.
- Never side load, back load, or tip load a hook. (See Figure 2).
- The use of a latch may be mandatory by regulations or safety codes; e.g., OSHA, MSHA, ANSI/ASME B30, insurance, etc. (Note: When using latches, see instructions in *Understanding: The Crosby Group Product Warnings* for further information.)
- Always make sure the hook supports the load (See Figure 3). The latch must never support the load (See Figure 4).
- When placing two (2) sling legs in hook, make sure the angle from the vertical to the outermost leg is not greater than 45 degrees, and the included angle between the legs does not exceed 90 degrees\* (See Figure 5).

\* For angles greater than 90 degrees, or more than two (2) legs, a master link or bolt type anchor shackle should be used to attach the legs of the sling to the hook.

- See ANSI/ASME B30.10 “Hooks” for additional information.
- In accordance with ANSI B30.9, all slings terminated by swaging shall be proof tested.
- S-319SWG hooks are designed to be a component of a system, and therefore rated based on the working limit of the system of which they are attached.
- The frame code on each S-319SWG hook is to facilitate proper latch selection only, and has no reference to the working load limit of the hook.

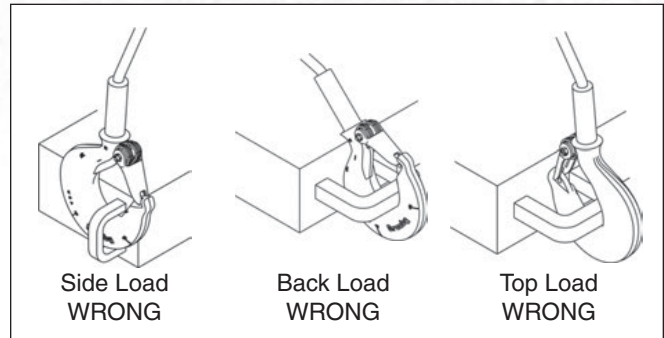

Figure 2

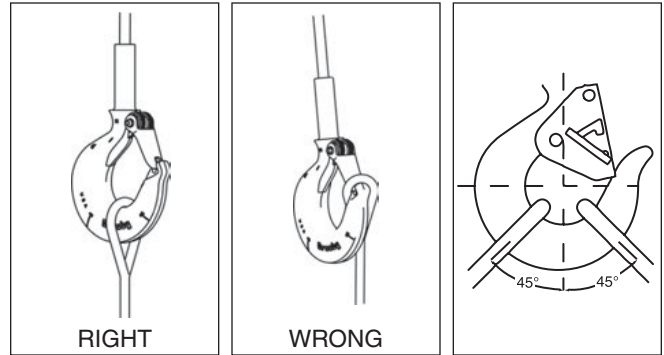

Figure 3

Figure 4

Figure 5

Wire Rope Size (mm)	Hook Frame I.D. Code†	Required Swaging Die		Maximum After Swage Dimensions (mm)
		Stock No.	Description	
4.75	DC	1191621	1/8" Swage Button Die	10.2
6.35	FC	1192845	1/4" Swage Socket Die	11.7
7.95	GC	1191621	1/4" Swage Button Die	14.7
7.95	HC	1192863	3/8" Swage Socket Die	18.0
9.55	HC	1192863	3/8" Swage Socket Die	18.0
11.1	IC	1192881	1/2" Swage Socket Die	23.1
12.7	IC	1192881	1/2" Swage Socket Die	23.1
14.3	JC	1192907	5/8" Swage Socket Die	29.5
15.9	JC	1192907	5/8" Swage Socket Die	29.5
19.1	KC	1192925	3/4" Swage Socket Die	36.1
22.2	LC	1192949	7/8" Swage Socket Die	39.4
25.4	NC	1192961	1" Swage Socket Die	45.7
28.6	OC**	1192989	1-1/8" Swage Socket Die	52.1

\*\* S319C Style Hook † See tables on pages 119 - 121



WARNINGS & APPLICATION INSTRUCTIONS



**⚠ WARNING**

- Incorrect use of WIRELOCK® can result in an unsafe termination which may lead to serious injury, death, or property damage.
- Do not use WIRELOCK with stainless steel rope in salt water environment applications.
- Use only soft annealed iron wire for seizing.
- Do not use any other wire (copper, brass, stainless, etc.) for seizing.
- Never use an assembly until the WIRELOCK has gelled and cured.
- Remove any non-metallic coating from the broomed area.
- Non Crosby sockets with large grooves need to have those grooves filled before use with WIRELOCK.
- Read, understand, and follow these instructions and those on product containers before using WIRELOCK.

The following simplified, step-by-step instructions should be used only as a guide for experienced, trained users. For full information, **Wire Rope End Terminations Manual, API (American Petroleum Institute) Recommended Practice 9B, ISO Standards, Wire Rope Manufacturers Catalogs, and Wire Rope Sling Users Manual.**

**STEP 1 – SOCKET SELECTION**

1. WIRELOCK® is recommended for use with Crosby 416-417 Spelter Sockets. Structural strand requires a socket with the basket length approximately 5 times the strand diameter or fifty (50) times the wire diameter, whichever is greater, to achieve 100% efficiency. Consult The Wire Rope End Terminations Manual for proper selection of Wire Rope or Structural Strand sockets.
2. For use with sockets other than Crosby 416-417 consult the socket manufacturer or Crosby Engineering.
3. Sockets used with WIRELOCK® shall comply with Federal or International (CEN, ISO) Standards.
4. WIRELOCK®, as with all socketing media, depends upon the wedging action of the cone within the socket basket to develop full efficiency. A rough finish inside the socket may increase the load at which seating will occur. Seating is required to develop the wedging action.

**STEP 2 – MEASURE AND SEIZE**

The rope ends to be socketed should be of sufficient length so that the end of the unlaidd wires (from the strands) will be at the top of the socket basket. Seizing should be placed at a distance from the end equal to the length of the basket of the socket.

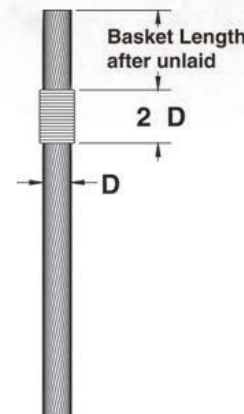

**STEP 3 – BROOMING**

1. Unlay the individual strands and fully broom out the wires of the wire rope and IWRC as far as the seizing. The wires should be separated but not straightened.
2. Cut out any fiber core.
3. Unlay the individual wires from each strand, including the IWRC, completely, down to the seizing.
4. Remove any plastic material from broomed area.



**STEP 4 – CLEANING**

1. The method of cleaning will depend on the lubricant and/or coating on the wire.
2. The methods and materials used for cleaning should comply with the current EPA regulations.
3. Consult your Wire Rope supplier or Wire Rope manufacturer for recommended material and methods. Follow the solvent supplier's recommendations for cleaning the broomed end.

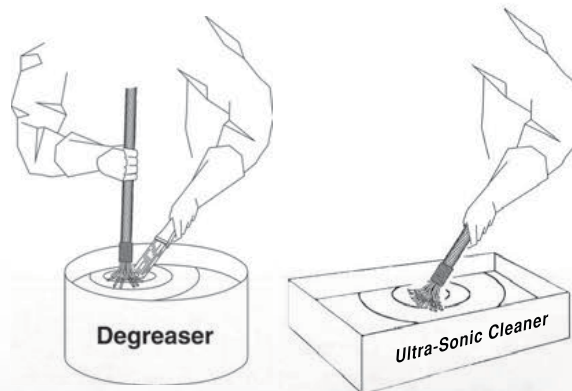

### STEP 5 – POSITIONING OF SOCKET

1. Position socket over the broom until it reaches the seizing on the wire rope. The wires should be LEVEL with the top of the socket basket.
2. Clamp rope and socket vertically ensuring alignment of their axes.
3. **CAUTION: DO NOT USE OVERSIZED SOCKETS FOR WIRE ROPE.**

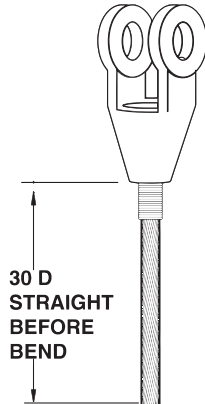

### STEP 6 – SEAL SOCKET

Seal the base of the socket with putty or plasticine to prevent leakage of the **WIRELOCK**®.



### STEP 7 – WIRELOCK® KITS

1. **WIRELOCK**® kits are pre-measured and consist of two (2) containers – one (1) with resin and one (1) with granular compound.
2. Use the complete kit – **NEVER MIX LESS THAN THE TOTAL CONTENTS OF BOTH CONTAINERS.**
3. Each kit has a shelf life clearly marked on each container and this must be observed. **NEVER USE OUT-OF-DATE KITS.**

#### **CAUTION**

- **WIRELOCK**® resin, in liquid state, is flammable.
- Chemicals used in this product can give off toxic fumes and can burn eyes and skin.
- Never use out-of-date material.
- Use only in well-ventilated work areas.
- Never breathe fumes directly or for extended time.
- Always wear safety glasses to protect eyes.
- Always wear gloves to protect hands.
- Avoid direct contact with skin anywhere.

### STEP 8 – MIXING AND POURING

1. Mix and pour **WIRELOCK**® within the temperature range of 48 degrees to 110 degrees F. Booster kits are available for reduced temperatures.
2. Wirelock is set up to gel in 20 minutes @ 65 F. For every 18 F rise in temperature the gel time will halve. At 83 F the gel time will be 10 minutes and at 101 F it will be 5 minutes. To give extra working time of pot life it is worth considering refrigerating the kits for two hours prior to mixing and pouring. The socket should also be as cool as possible - out of direct sunlight, as an example.
3. Pour all the resin into a container containing all the granular compound and mix thoroughly for two (2) minutes with a flat paddle.
4. The **WIRELOCK**® will turn a green blue color. If it does not turn a green blue after mixing, **DO NOT USE.**
5. Immediately after mixing, slowly pour the mixture down one side of the socket until the socket basket is full.
6. Check for leakage at nose of socket, add putty if required.

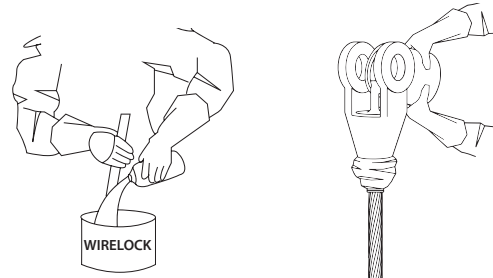

### STEP 9 – CURING

1. **WIRELOCK**® will gel in approximately 15 minutes, in a temperature range 64 degrees F (18 degrees C) to 75 degrees F (24 degrees C).
2. The socket must remain undisturbed in the vertical position for an additional ten (10) minutes after gel is complete.
3. The socket will be ready for service 60 minutes after gelling.
4. Never heat sockets to accelerate gel or curing.



### STEP 10 – RE-LUBRICATION

Re-lubricate wire rope as required.

### STEP 11 – PROOF LOADING

Whenever possible, the assembly should be proof loaded. In accordance with ASME B30.9.

### ALTERNATE SEIZING AND BROOMING METHOD

Reference the **Wire Rope End Terminations User's Manual** from Crosby for an alternative socketing method.



# NATIONAL SWAGING MACHINE AND DIE WARNING, USE, MAINTENANCE AND APPLICATION INFORMATION

## National Four Post Swaging Machine



### Operation Safety



- NEVER use dies that are cracked, worn or abraded (galled).
- NEVER use dies that have an oversized cavity.
- ALWAYS use a matched set of dies.
- When swaging steel fittings, DO NOT SHIM DIES. Dies for steel fittings must be free to float and align one to the other.
- When swaging aluminum fittings, THE STEEL DIES MUST BE SHIMMED. Shim the side of the die to ensure the proper cavity alignment for flash removal.
- NEVER shim between the dies.
- When Swaging Crosby National fittings, use only the proper capacity swaging machine for the size of fitting used (See Swaging Capacity Chart). If the swaging machine capacity exceeds the die block Working Load Limit rating, adjust the swaging machine tonnage to the Working Load Limit shown on the die block being used. See Table 1 for die block Working Load Limit.
- Always use the correct size and type of die for the size wire rope fitting used.
- Make sure that the manufacturer's die retention locking pin, bolt, or other device is engaged and has secured the die before swaging. Make sure that the dies are straight, parallel, and perpendicular to each other before and during the swaging procedure.
- Always lubricate die faces and cavities with light weight oil.
- Progressive swaging of fittings must be done in accordance with procedure shown in "Wire Rope End Terminations User's Manual". Only open channel dies are to be used.
- Stop swaging when the cavity side of both dies touch. Observe the die closure from above and slightly to the side. The best position is to stand 45 degrees to either side of the front.
- Make sure part is swaged to the recommended after swage dimensions (See "Wire Rope End Terminations Manual", Die Guide, or Die Chart).
- If a swage fitting other than a Crosby National is used, determine adequacy of the termination by a destructive pull test.
- All swage sockets must be swaged with socket head adjacent to the socket relief (largest radius) on the die.
- For special applications or conditions, contact Crosby National (501)962-3112.

### ⚠ WARNING

- Misuse of swaging machine can result in serious injury or death.
- READ, UNDERSTAND, AND FOLLOW all the information in this warning document and the instructions shown in "Wire Rope End Terminations User's Manual" before operating the swaging machine.
- Swaging machine operators must be trained in accordance with the information supplied by The Crosby Group LLC. THE SWAGING MACHINE OWNER IS RESPONSIBLE FOR THE TRAINING AND THE SAFE OPERATION OF THE SWAGING MACHINE.
- Do not swage oversize parts.
- Only swage parts of the proper design, material and hardness.
- If misused, dies and/or die holders may break. PROTECT YOURSELF AND OTHERS: Always stay away from the sides of the swaging machine during swaging operations and alert others in your work area.
- Do not shim between dies.
- Do not shim die or die holder unless swaging aluminum sleeves.
- Do not use die holders that are damaged or have loose side rails or side plates.
- Tie rod nuts must be secured to the tie rods with a secondary retention system.
- Keep head, hands, and body away from moving swaging machine and die parts.
- Consult die manufacturer for correct use of their product.
- Adjust swaging machine tonnage to the Working Load Limit (WLL) tonnage shown on the die block being used. If the Working Load Limit is not legible, refer to Die height & width and corresponding Working Load Limit (See Table 1). Failure to do so can result in serious injury or death.

TABLE 1

Die Size (Height x Width)	Working Load Limit (WLL)*
50mm x 88.9mm	200 Ton Mark Series
63.5mm x 102mm	200 Ton National
63.5mm x 127mm	500 Ton Mark Series
102mm x 178mm	1,200 Ton Mark Series
127mm x 178mm	1,500 Ton National
152mm x 305mm	3,000 Ton National

## Inspection Maintenance Safety

- Make sure the swager is in good operating condition and that all gauges, indicators and controls are working properly.
- Make sure all bolts and nuts are in place and tightened to recommended torque as shown in Table A, on page 67 for new style swaging machines, and Table B on page 68 for current swaging machines.
- Load block or die base plate surfaces must be to manufacturers specifications for thickness and flatness to provide complete support of the die during swaging.
- Make sure die holder side rails are not bent, loose or damaged.
- Clean dies and die holder surfaces. Keep free of metal shavings, slag, grit, sand, floor dry, etc.
- Lubricate the four guide bushings daily with light oil.
- Inspect the rods for corrosion. Use #000 emery cloth or steel wool to maintain a high polish surface.
- Do not increase the hydraulic system pressure above the factory preset pressure of: 6500 psi for 500 ton, 1000 ton and 1500 ton swaging machines – 5000 psi for 3000 ton swaging machine.
- Under ordinary operating conditions, drain and clean reservoir every two (2) years.
- Make certain that the hydraulic reservoir is full when the swager is in the full open position.
- Filters inside of the reservoir should be cleaned every time the reservoir is drained and cleaned. The Racine “tell-tale” suction filter should be cleaned every six (6) months.

### Die Working Load Limit Pressure Adjustment on Lower Cylinder National 500 Ton through 1500 Ton Swaging Machines

Follow this procedure to adjust swaging tonnage (pressure) on your swaging machine.

1. Install the die holder(s) or die adapter with the dies to be used.
2. Bring the dies together (without a part in the dies) until they just touch.
3. Turn the tonnage control valve, which is located on the control panel left of the tonnage gauge, counter-clockwise about (6) six turns or until knob no longer turns.
4. Now (without a part in the dies) apply pressure to the dies by pressing the foot pedal marked “up”:
  - A. If the tonnage is lower than desired Working Load Limit, turn the valve clockwise while continuing to press the foot pedal marked “up” until desired Working Load Limit is reached.
  - B. If tonnage is higher than desired Working Load Limit, release pressure by pressing the pedal marked “down.” Then repeat steps 2 through 4.

### Die Working Load Limit Pressure Adjustment on 3000 Ton Swaging Machine

For reducing tonnage, use selector switch on front of control panel to select lower tonnage (approximately 1500 Tons) or 3000 Ton.



**WARNING**

ALWAYS USE 5 X 7 OR 6 X 12 DIES AT 1500 TON SETTING.



**WARNING**

USE ONLY 6 X 12 DIES ON TONNAGE THAT EXCEEDS 1500 TONS.

### Swaging Machine Capacity Chart for Swage Sleeves, Ferrules and Buttons

Hydraulic Swaging Machine Size	Swaging Method	Die Size (in.)	Largest Fitting Allowed to be Swaged (mm)*		
			S-505 Sleeve	S-506 Sleeve	S-409 Buttons
500 Ton	Full Die	Mark Series 2-1/2 x 5 4 x 5 5 x 7	38	32*	22
1000 Ton	Full Die	4 x 7 5 x 7	64	32*	32*
1500 Ton	Full Die	5 x 7 6 x 12	89	32*	32*
3000 Ton	Full Die	6 x 12	114*	32*	32*

\* Largest size fitting available.

### Swaging Machine Capacity Chart for S-501 and S-502 Swage Socket

Hydraulic Swaging Machine Size	Swaging Method	Die Size (in.)	Largest Fitting Allowed to be Swaged (mm)*
500 Tons	Full Shank	Mark Series 2-1/2 x 5 4 x 7 5 x 7	19
	Progressive	4 x 7 5 x 7	32
1000 Tons	Full Shank	4 x 7 5 x 7	26
	Progressive	4 x 7	38
1500 Tons	Full Shank	5 x 7 6 x 12	32
	Progressive	5 x 7 6 x 12	52
3000 Tons	Full Shank	6 x 12	52
	Progressive	6 x 12	52*

\* Largest size fitting available.



# “NEW STYLE” NATIONAL HYDRAULIC SWAGING MACHINE TORQUE MAINTENANCE INFORMATION

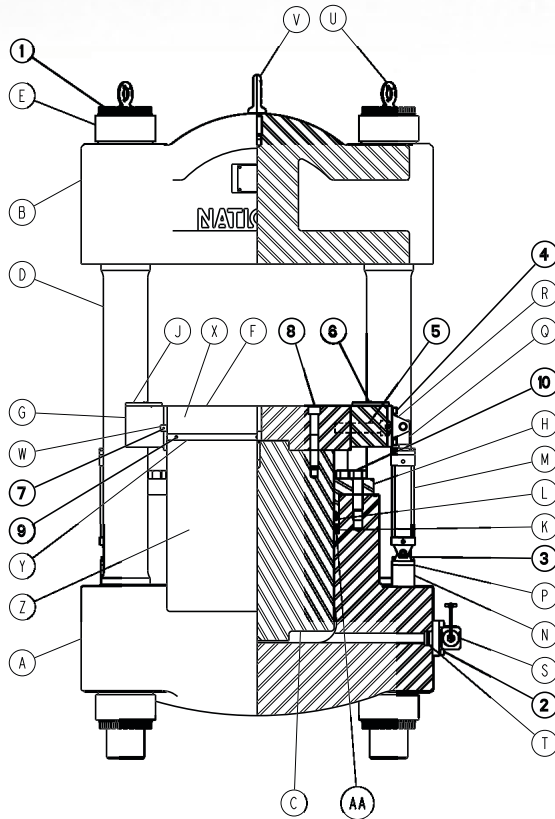

Item	No. Req'd.	Description
A	1	Cylinder
B	1	Housing Cap
C	1	Piston
D	4	Tie Rod
E	8	Tie Rod Nut
F	1	Platen
G	2	Guide
H	1	Gland
J	4	Bushing
K	1	Mono Seal
L	1	Seal Spacer
M	2	Side Cylinder
N	2	Side Cylinder Mount
P	2	Lower Bracket
Q	2	Knuckle
R	2	Upper Bracket
S	1	Check Valve
T	1	Check Valve Seal
U	4	Tie Rod Eyebolt
V	1	Cap Eyebolt
W	4	Key
X	2	Bumper
Y	2	Bumper Strip
Z	2	Rubber Skirt
AA	1	Bottom of Seal Cavity

Item No.	No. Req'd.	Description	Torque in Nm			
			500 Ton Swaging Machine	1000 Ton Swaging Machine	1500 Ton Swaging Machine	Maintenance Schedule
1	Varies	Tie Rod Nut Jack-Bolts	142	N/A	353	Weekly
2	4	Check Valve Bolts	136	136	136	Weekly
3	8	Lower Bracket Bolts	136	136	136	Weekly
4	8	Upper Bracket Bolts	136	136	136	Weekly
5	4	Guide Bolts	339	339	339	Weekly
6	8	Bushing Screws	20	20	20	Weekly
7	4	Key Screws	5	5	5	Weekly
8	4	Platen Bolts	712	814	949	Monthly
9	6	Bumper Apron Screws	5	5	5	Monthly
10	12	Gland Bolts	949	1085	1085	Monthly

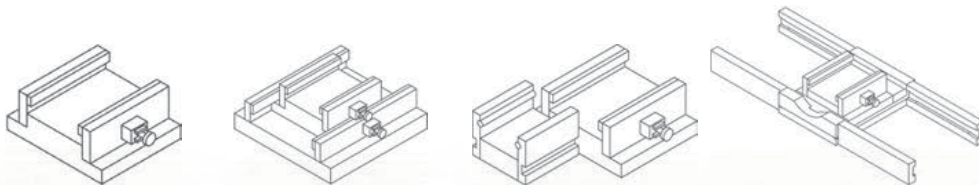

	Bolt Size Thread Form	Torque in Nm
Die Holder Bolt	1/4 20 UNC	18
	5/16 18 UNC	20
Torque	5/8 11 UNC	286
	7/8 9 UNC	790

**WIRE ROPE END FITTINGS**

# NATIONAL HYDRAULIC SWAGING MACHINE TORQUE MAINTENANCE INFORMATION

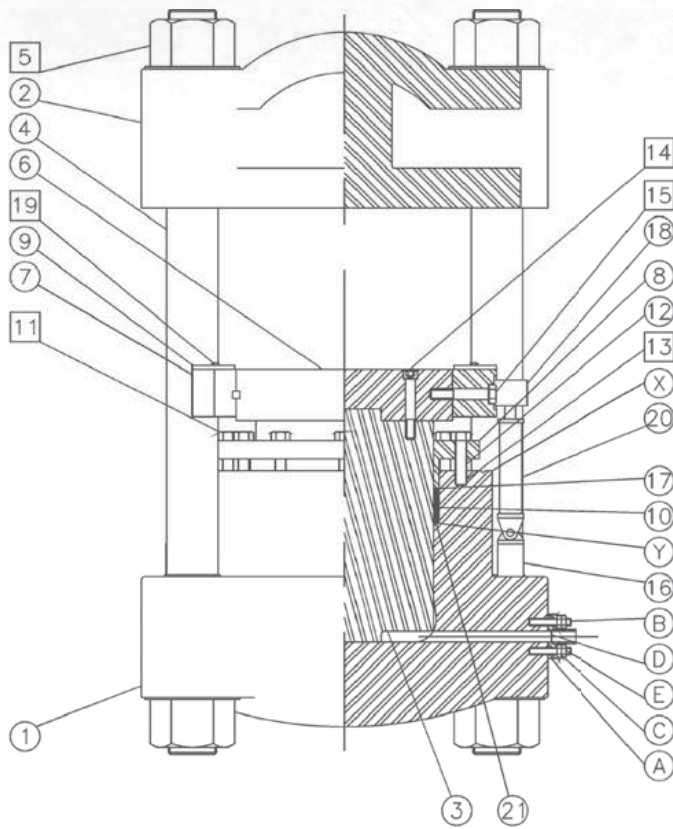

Item	No. Req'd.	Description
1	1	Cylinder
2	1	Housing Cap
3	1	Piston
4	4	Tie Rod
5	8	Nut
6	1	Platen
7	2	Guide
8	1	Gland
9	4	Bushing
10	1	Packing Set
11	12	Packing Gland Nut
12	4	Packing Gland Spacer
13	12	Stud
14	4	Cap Screw
15	4	Cap Screw
16	2	Lower Bracket
17	1	Upper Bronze Ring
18	2	Upper Bracket
19	8	Machine Screw
20	2	Side Cylinder
21	1	Lower Bronze Ring
A	1	Block
B	4	Stud
C	4	Nut
D	1	Copper "O" Ring
E	4	Lock Nut
X	1	Top of Cylinder
Y	1	Bottom of Packing Cavity

Table B						
Item No.	Description	Torque in Nm				Maintenance Schedule
		500 Ton Swaging Machine	800 Ton Swaging Machine	1000 Ton Swaging Machine	1500 Ton Swaging Machine	
5	Tie Rod Nuts	2712	3051	3390	3390	Weekly
14	Piston Bolts	712	814	814	950	Monthly
11	Packing Gland Nuts (over spacers only) "all others hand tighten"	270	270	270	270	Weekly
15	Platen Guide Bolts	240	340	340	340	Weekly
13	Packing Gland Bolts	950	1085	1085	1085	6 Months
	Side Cylinder Bolts	136	N/A	136	200	Weekly
19	Guide Bushing Bolts	20	20	20	20	Weekly
	80 M Piston Pump Pistons	96 to 125 all Swaging Machines				

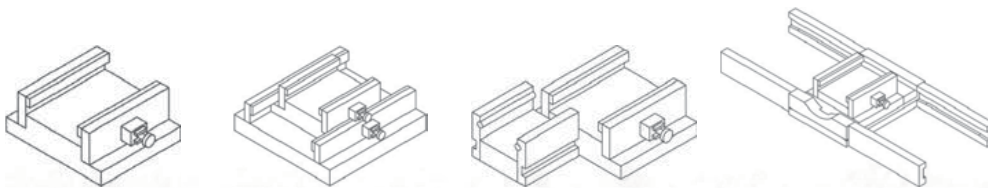

	Bolt Size Thread Form	Torque in Nm
Die	1/4 20 UNC	18
Holder	5/16 18 UNC	20
Bolt Torque	5/8 11 UNC	286
	7/8 9 UNC	790



## DIE INFORMATION

### CAUTION ⚠

- **Improper die selection could result in significant loss of efficiency in the termination.**

National dies and die holders are made solely for swaging properly designed fittings on wire rope, and any other uses are prohibited.

The swaging operation results in a high degree of cold metal flow. The movement that occurs between the fitting and the dies will cause wear of the dies. Therefore, to prolong the life of the dies, it is important to always lubricate die faces and cavities between each pass with a light weight oil or high pressure grease.

When scores appear in the die cavities, the dies should be removed from service.

### **NEVER EXCEED THE WORKING LOAD LIMIT OF DIES OR DIE HOLDERS.**

All National Standard dies 1/4" through 1" include an open channel die cavity and a tapered die cavity in the same die block.

#### **Dies for S-505 Standard Steel Sleeves (Flemish Eyes)**

##### *Die sizes for 1/4" through 1"*

Swaging 1/4" through 1" Standard Steel S-505 sleeves on Flemish Eye terminations requires the use of the taper cavity only. Refer to page 24 of the *Wire Rope End Termination User's Manual* for proper die selection.

##### *Die sizes for 1-1/8" and above*

Swaging 1-1/8" and larger Standard Steel S-505 sleeves on Flemish Eye terminations requires using 2 sets of open channel dies (1st stage and 2nd stage) for each size. Beginning with the 1st stage die and finishing with the 2nd stage die will achieve proper after swage dimensions. Dies for S-505 Sleeves 1-1/8" and larger are single cavity with open channel. Refer to page 24 of the *Wire Rope End Termination User's Manual* for proper die selection.

#### **Using S-505 Sleeves with Metric Ropes**

Although Crosby National S-505 Standard Steel sleeves are designed to be used with most metric ropes, there are selected "intermediate" sizes of metric ropes that when swaged in standard National dies utilizing Crosby National S-505 sleeves do not achieve required after swage dimensions and efficiencies. To ensure all 505 sleeves achieve the required efficiency when used with metric ropes, Crosby provides special National swaging dies to be used in conjunction with selected size metric ropes. These new dies will produce the required efficiencies and after swage dimensions.

The table found on page 46 of this catalog or page 25 of the *Wire Rope End Termination User's Manual* identifies the new dies that are required to properly swage the selected intermediate size wire ropes not covered in the standard product offering found on page 45 of this catalog or page 24 of the manual.

*Dies for 6mm through 26mm (except 12mm, 20mm and 24mm)*

Swaging on 6mm through 26mm metric ropes for Flemish Eye slings requires the selection of the proper S-505 Standard Steel sleeve and the use of the tapered cavity only. Refer to page 24 of the *Wire Rope End Termination User's Manual* for proper sleeve and die selection.

*Dies for 12mm, 20mm and 24mm*

Swaging on 12mm, 20mm and 24mm metric ropes for Flemish Eye slings requires the selection of the proper S-505 Standard Steel sleeve and the use of both the open cavity and tapered cavity in special dies. Refer to page 25 of the *Wire Rope End Termination User's Manual* for proper sleeve and die selection.

*Dies for 28mm and larger*

Swaging on 28mm and larger metric ropes for Flemish Eye slings requires the selection of the proper S-505 Standard Steel sleeve and the use of 2 sets of open channel dies (1st stage and 2nd stage) for each size. Beginning with the 1st stage die and finishing with the 2nd stage die will achieve proper after swage dimensions. Dies for S-505 sleeves 28mm and larger are single cavity with open channel. Refer to page 24 of the *Wire Rope End Termination User's Manual* for proper sleeve and die selection.

Important: If the specific size metric rope required is not listed on page 24 of the *Wire Rope End Termination User's Manual* refer to Intermediate Metric Die Chart on page 25 of the manual for proper sleeve and die selection.

*Dies for QUIC-PASS® Swaging System – 1/4" through 1-1/2"*

The QUIC-PASS® swaging system allows "Flemish style" wire rope terminations to be swaged in only two passes. This is accomplished while maintaining currently published efficiency ratings and utilizing National Swage S-505 Standard "COLD TUFF"® Steel Sleeves.

The special design of the QUIC-PASS® dies allows the swaging process to be completed in just two passes, resulting in a 50-75% reduction in the number of passes required with conventional swaging systems. Unlike standard round dies, the QUIC-PASS® dies close completely with each pass, resulting in an increase in overall swaging process efficiencies (the job can be performed quicker), a reduction in the complexity of swaging (the concern for excess flashing between dies has been eliminated) and a reduction in training time needed for operators (more user friendly).

The finished sleeve has a "Hex" appearance that provides a QUIC-CHECK® look to determine if the termination has been swaged and provides a flat surface that allows for ease of I.D. stamping on the finished sleeve. Refer to page 24 of the *Wire Rope End Termination User's Manual* for proper die selection.



### Dies for S-501 & S-502 Swage Sockets

Swaging all S-501 & S-502 Swage Sockets requires the use of single cavity die. This is a special die designed with a relief for swage sockets and extra length to swage the full length of the shank. Refer to pages 36 and 37 of the *Wire Rope End Termination User's Manual* for proper die selection.

#### Swage Sockets for Spiral Strand Rope

Our tests indicate that if the spiral strand is 1 x 19 or greater, and the ultimate strength does not exceed Table 1 of ASTM A586, you can use dies for size swage sockets up to the 1-1/4". For sizes greater than 1-1/4" the following will apply:

1. Closed S-502 Sockets: One (1) socket size larger with shank modified for actual strand diameter 1-3/8" through 2".
2. Open S-501 Sockets: One (1) socket size larger with shank modified for actual strand diameter 1-3/8" through 2".
3. If the strand is of greater strength than Table 1 of ASTM A586 or has less metallic area, we must recalculate the design and test for adequacy.

### Dies for S-506 Turnback Sleeves

Turnback eye terminations using 5/16" through 1" S-506 Sleeves utilize the S-505 Standard Steel Sleeve die (1st Stage open channel die only). The 1-1/4" S-506 Sleeve utilizes the 1-3/8" socket (S-501 and S-502) die. Refer to page 46 of the *Wire Rope End Termination User's Manual* for proper die selection.

### Dies for S-409 Buttons

Buttons are swaged in open channel dies. Refer to page 42 of the *Wire Rope End Termination User's Manual* or on page 47 of this catalog for proper die selection.

Specific recommended swaging practices can be found in each product section of this catalog. The proper die selection and the recommended maximum after swage dimensions are referenced in the section of this catalog that contains the product you are swaging. This information can also be found in the National Swage Die Guide, or by referring to the National Swage Die Chart.

Dies and die adapters to fit other type swaging machines are available upon request (Refer to page 19 of the *Wire Rope End Termination User's Manual*).



Single Cavity Die



Two Cavity Die



Never use dies that are cracked, worn or abraded (galled).



## After Swage Inspection Procedures

### **⚠ WARNING**

- Read, understand, and follow these instructions before using the National QUIC-PASS® Swaging System.
- Improper after swage dimensions can result in sling failure resulting in property damage, serious injury or death.
- Always gauge or measure the after swage dimensions to ensure proper sling performance.
- Using National Swaging System with ropes and termination styles other than shown in these procedures may reduce the performance of the termination and lead to premature failure.
- When using rope constructions other than shown in this procedure, the termination must be destructive tested and documented to prove adequacy of the assembly to be manufactured.
- The QUIC-PASS® Swaging System is designed only for “Flemish Eye” terminations using National S-505 Standard Steel Sleeves.
- The QUIC-PASS® Swaging System is not designed for Cable-Laid wire rope slings.

### Checking Swaging Dimensions

One of the important considerations in producing a quality termination is the overall diameter of the fitting after the swaging process is complete. Since all dies wear, and the swaged fitting used in terminations has spring back, the results of swaging should be checked periodically to determine the wear condition of the die as well as to ensure the fitting is swaged to proper dimensions.

### Key Facts About After Swage Dimensions:

1. In addition to worn dies, not achieving the proper after swage dimension can also be due to the die not being fully closed during swaging. Dies showing excessive wear should be replaced.
2. The effective swaging that dies can accomplish stops when the die lands touch each other. Any continued swaging adds needless wear and strain on the dies and swaging machine.
3. By placing a light oil on the die faces and in the cavity, the dies will be lubricated as well as protected.
4. The oozing of the oil from the faces of the dies as they touch will indicate when the dies have closed. At this point, stop the swaging cycle.
5. Additional swaging adds needless wear and strain to the dies and swaging machine.
6. Never use dies that are cracked, worn or abraded (galled).
7. The Crosby Group does not recommend the checking of die dimensions as an acceptable method of determining the quality of a swage sleeve, button, ferrule, or socket.
8. It is our recommendation that the checking of the after swage dimension of the swaged fitting is the most accurate indicator of a properly swaged termination. Measuring the die cavity only is not an acceptable process control check.
9. If the die cavity wears, the dies are not closed completely during swaging. If an inadequate number of presses are used, it could be quickly identified by checking the after swage dimension of the part.
10. Swaging Machine not producing sufficient tonnage will affect after swage dimensions.

### No-Go Gauge Information

To assist in checking the after swage dimensions of the fitting, the Crosby Group provides the National No-Go Gauges. When used correctly the National No-Go Gauges can determine if the fittings were swaged to the proper diameter. We would recommend that all Crosby products or product swaged in Crosby dies be checked with the proper gauge to determine the acceptability of the swaging process.

- Gauges are made of hardened alloy steel and machined to strict tolerances.
- Gauge can be used to verify that all fittings have been swaged properly.
- After swage dimensions not within the maximum limits may result from worn dies or improper swaging techniques.
- Other type gauges are available upon request.
- National No-Go Gauges are available for a variety of products (See Table 1).
- **No-Go Gauges and QUIC-PASS® No-Go Gauges are not interchangeable.**

Table 1 - Standard Round No-Go Gauges	
Fitting and Size	Part No.
505 Sleeve 1/4 - 7/8	1095512
505 Sleeve 1 - 1-1/2	1095521
505 Sleeve 1-3/4	1095530
505 Sleeve 2	1095549
505 Sleeve 2-1/4	1095558
505 Sleeve 2-1/2	1095587
505 Sleeve 2-3/4	1095576
505 Sleeve 3	1095565
505 Sleeve 3-1/2	1095594
505 Sleeve 3-3/4	1095601
505 Sleeve 4	1095610
501/502 Socket 1/4 - 1	1095647
501/502 Socket 1-1/8 - 1-3/4	1095656
501/502 Socket 2	1095665

### Using No-Go Gauges

When swaged properly, the gauge will go up and down (see Figure 1) and around the full length of the fitting (see Figure 2).

For the proper after swage dimensions, see the section in this publication for the specific product you are swaging.

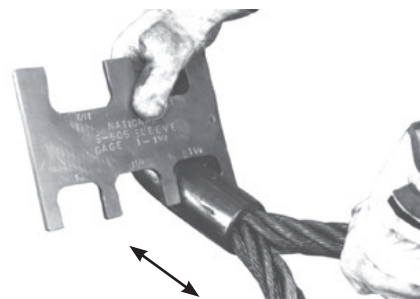

Figure 1



Figure 2



## QUIC-PASS® No-Go Gauges

As a further aid, QUIC-PASS® No-Go gauges are available for checking the sleeve's dimensions after swaging is complete.

- Gauges are made of hardened alloy steel and machined to strict tolerances.
- Gauge can be used to verify that all sleeves have been swaged properly.
- "After Swage" dimensions not within the maximum limits may result from worn dies or improper swaging techniques.
- **No-Go Gauges and QUIC-PASS® No-Go Gauges are not interchangeable.**

QUIC-PASS® No-Go Gauges	
Sleeve and Size	Stock No.
No-Go Gauge for S-505 1/4" - 7/8"	1923705
No-Go Gauge for S-505 1" - 1-1/4"	1923712
No-Go Gauge for S-505 1-3/8" - 1-1/2"	1923714

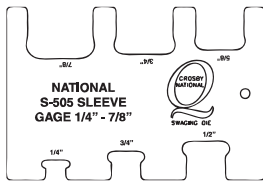

Stock No.  
1923705

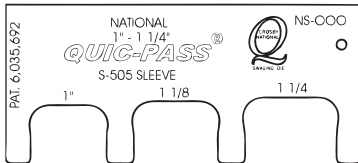

Stock No.  
1923712



Stock No.  
1923714

Use a National QUIC-PASS® No-Go Gauge to check the after swage dimensions to ensure that it has been swaged to the proper dimension. When swaged properly, the gauge will slide up and down the full length of the sleeve on all three sets of opposing flats.

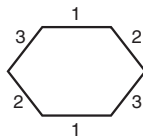

## QUIC-PASS® Maximum After Swage Dimensions

Size (in.)	Maximum "After Swage" Dimension (in.)
1/4	0.565
5/16 - 3/8	0.769
7/16 - 1/2	1.016
9/16 - 5/8	1.247
3/4	1.475
7/8	1.738
1	1.955
1-1/8	2.170
1-1/4	2.405
1-3/8	2.610
1-1/2	2.835

## Important Safety Information

- **Crosby does not recommend** a "Texas Tuck" style termination with Crosby National S-505 "COLD TUFF®" Standard Steel Sleeves.
- Only Crosby National S-505 "COLD TUFF®" Standard Steel Sleeves are recommended when using the QUIC-PASS® Swaging System.
- National S-505 Standard Steel Sleeves, when used with the QUIC-PASS® Swaging System, are only recommended for use with one (1) part 6 X 19 or 6 X 37, IPS or XIP (EIP), XXIP (EEIP), RRL, IWRC rope.
- The condition of the swaging machine can cause sleeve "After Swage" size not to be within the proper dimensions. Example: worn bushings, loose tie rods, loose die holders, misaligned platens, worn pins, worn linkage, etc.
- Swaging dies being worn, damaged, misused, or undersized can cause sleeve "After Swage" size not to be within the proper dimension.
- Swaging die holders excessively worn, damaged, misused or loose can cause sleeve "After Swage" size not to be within the proper dimension. Only use QUIC-PASS® dies and die holders inspected and properly secured in National swaging machines.
- Always refer to Warning and Application information found in this catalog and *Wire Rope End Terminations User's Manual*.





# SHACKLES

With Product Warning and Application Information





**Crosby**

**"There is No Equal"**



The Market Leader: Yesterday Today and Tomorrow

## Shackles

### DESIGN

The theoretical reserve capability of carbon shackles should be as a minimum 5 to 1, and alloy shackles a minimum of 5 to 1\*. Known as the DESIGN FACTOR, it is usually computed by dividing the catalog ultimate load by the working load limit. The ultimate load is the average load or force at which the product fails or no longer supports the load. The working load limit is the maximum mass or force which the product is authorized to support in general service. The design factor is generally expressed as a ratio such as 5 to 1. Also important to the design of shackles is the selection of proper steel to support fatigue, ductility and impact properties.

### THE COMPETITION

- Ask:** *What is the Working Load Limit and design factor for shackles?*
- Ask:** *Is deformation upon overloading a critical consideration in their design?*
- Ask:** *Do they jeopardize other properties by having hardness high in order to increase working load or design factor?*

**Crosby**

Crosby carbon shackles have the highest design factor (6 to 1) in the industry. All of Crosby's design factors are documented. Crosby purchases only special bar forging quality steel with cleanliness and guaranteed harden ability. All material chemistry is independently verified prior to manufacturing. The design of Crosby shackles assures that strength, ductility and fatigue properties are met.

**Load Rated**

### CLOSED DIE FORGED

The proper performance of premium shackles depends on good manufacturing techniques that include proper forging and accurate machining. Closed die forging of shackles assures clear lettering, superior grain flow, and consistent dimensional accuracy. A closed die forged bow allows for an increased cross section that, when coupled with quench and tempering, enhances strength and ductility. Closed die bow forgings combined with close tolerance pin holes assures good fatigue life. Close pin-to-hole tolerance has been proven to be critical for good fatigue life, particularly with screw pin shackles.

### THE COMPETITION

- Ask:** *Are their shackles closed die forged with close tolerance pin holes?*
  - Ask:** *Do their shackles have good fatigue life?*
  - Ask:** *Do their shackles have a fatigue life that meets the new world standards?*
- Many forge bows, utilizing an open die forging process which allows for inconsistent dimensional accuracy and increased pin hole clearance, thus jeopardizing the fatigue life of the shackle in actual use.*

**Crosby**

Each shackle is closed die forged. Closed die forging produces consistent dimensions. A closed die forged bow allows for an increased cross section that, when coupled with quench and tempering, enhances strength and ductility. Close tolerance holes and concentric pins with good surface finishes are provided by Crosby and are proven to provide improved fatigue life in actual use. Crosby shackles are fatigue rated as well as load rated. Close pin to hole tolerance has been proven to be critical for good fatigue life, particularly with screw pin shackles.

**Fatigue Rated**

### QUENCHED AND TEMPERED

Quench and tempering assures the uniformity of performance and maximizes the properties of the steel. This means that each shackle meets its rated strength and has required ductility, toughness, impact and fatigue properties. The requirements of your job demand this reliability and consistency. This quench and tempering process develops a tough material that reduces the risk of brittle, catastrophic failure. The shackle bow will deform if overloading occurs, giving warning before ultimate failure.

### THE COMPETITION

- Ask:** *Are their bows and pins quenched and tempered?*
- Ask:** *If not, are they willing to accept the increased risk of inconsistency?*
- Ask:** *If not, why are they willing to accept inferior impact, toughness, and product deformation?*
- Ask:** *Why do many manufacturers not recommend non-heat-treated shackles for overhead lifting?*
- Ask:** *Why do some recommend Quench and Tempering for alloy but not carbon grades?*

Many normalize the shackle bows. As a result, desired properties are not achieved. A few even provide bows in an "as-forged" condition, resulting in the possibility of brittle failure.

**Crosby**

All Crosby shackle bows and pins are quenched and tempered, which enhances their performance under cold temperatures and adverse field conditions. Crosby's Quenched and Tempered carbon shackles are recommended for all critical applications including overhead lifting. Alloy shackles are recommended when specific dimensional requirements dictate a size that requires higher working load limits. Crosby's Quenched and Tempered shackles provide the tensile strength, ductility, impact and fatigue properties that are essential if they are to perform time after time in adverse conditions. These properties assure that the inspection criteria set forth by ANSI will effectively monitor the ability of the shackles to continue in service.

**"QT"**  
QUENCHED & TEMPERED

### IDENTIFICATION AND APPLICATION INFORMATION

The proper application of shackles requires that the correct type and size of shackle be used. The shackle's working load limit, its size, a traceability code and the manufacturer's name should be clearly and boldly marked in the bow. Traceability of the material chemistry and properties is essential for total confidence in the product. Material chemistry should be independently verified prior to manufacturing.

### THE COMPETITION

- Ask:** *Do they have an active traceability system used in manufacturing?*
- Ask:** *Is the material chemistry independently verified?*
- Ask:** *What training support is provided?*

**Crosby**

Crosby forges "Crosby" or "CG", the Working Load Limit, and the Product Identification Code (PIC) into each bow and "Crosby" or "CG", and the Product Identification Code (PIC) into each pin of its full line of screw pin, round pin, and bolt type anchor and chain shackles. Seminars conducted by Crosby provide training on the proper use of shackles. Crosby training packets, supplied free to attendees of Crosby seminars, provide training materials needed to explain the proper use of shackles.

QUIC-CHECK®

\* G-2160 Wide Body Shackles are metric rated at 5 to 1. G-2140 Shackles, 200 ton and above, are rated at 4 to 1 in short tons.

**Remember: "When buying Crosby, you're buying more than product, you're buying Quality."**



# Crosby® VALUE ADDED

- **Charpy impact properties:** Crosby's Quenched and Tempered shackles have enhanced impact properties for greater toughness at all temperatures. If requested at the time of order, Crosby can provide Charpy impact properties.
- **Fatigue properties:** Fatigue properties are available for 1/3 to 55 metric ton shackles. These Crosby shackles are fatigue rated to 20,000 cycles at 1-1/2 times the Working Load Limit.
- **Ductility properties:** Typical ductility properties are available for all sizes upon special request.
- **Hardness levels and material tensile strengths:** Typical values are available for all sizes of shackles, and actual values can be furnished if requested at the time of order.
- **Proof Testing:** If requested at the time of order, shackles can be proof tested with certificates.
- **Mag Certification:** If requested at the time of order, shackles can be Mag inspected with certificates.
- **Certification:** Certification to world class standards is available upon special request at the time of order; American Bureau of Shipping, Lloyds Register of Shipping, Det Norske Veritas, American Petroleum Institute, RINA, Nuclear Regulatory Commission, and several other worldwide standards.
- **Applications:** **Round Pin Shackles** can be used in tie down, towing, suspension or lifting applications where the load is strictly applied in-line. **Screw Pin Shackles** can be used in any application where a round pin shackle is used. In addition, screw pin shackles can be used for applications involving side-loading circumstances. Reduced working load limits are required for side-loading applications. **Bolt-Type Shackles** can be used in any application where round pin or screw pin shackles are used. In addition, they are recommended for permanent or long-term installations and where the load may slide on the shackle pin causing the pin to rotate.
- **Material analysis:** Crosby can provide certified material (mill) analysis for each production lot, traceable by the Product Identification Code (PIC). Crosby, through its own laboratory, verifies the analysis of each heat of steel. Crosby purchases only **special bar** forging quality steel with specific cleanliness requirements and guaranteed hardenability.
- **Field inspection:** Written instructions for visual, magnaflux, and dye penetrant inspection of shackles are available from Crosby. In addition, acceptance criteria and repair procedures for shackles are available.
- **QUIC-CHECK®:** Shackles incorporate two marking indicators forged into the shackle bow at 45° angles from vertical. These are utilized to quickly check the approximate angle of a two-legged hitch or check the angle of a single leg hitch. If the load is off vertical or side loaded a reduction in the working load limit of the shackle is required.

## G-209

Screw pin anchor shackles meet the performance requirements of Federal Specification RR-C-271F Type IVA, Grade A, Class 2, except for those provisions required of the contractor.



## G-213

Round pin anchor shackles meet the performance requirements of Federal Specification RR-C-271F Type IVA, Grade A, Class 1, except for those provisions required of the contractor.



## G-2130

Bolt-type anchor shackles meet the performance requirements of Federal Specification RR-C-271F Type IVA, Grade A, Class 3, except for those provisions required of the contractor.



## G-210

Screw pin chain shackles meet the performance requirements of Federal Specification RR-C-271F Type IVB, Grade A, Class 2, except for those provisions required of the contractor.



## G-215

Round pin chain shackles meet the performance requirements of Federal Specification RR-C-271F Type IVB, Grade A, Class 1, except for those provisions required of the contractor.



## G-2150

Bolt-type chain shackles meet the performance requirements of Federal Specification RR-C-271F Type IVB, Grade A, Class 3, except for those provisions required of the contractor.







**G-213/S-213**

G-213 Round pin anchor shackles meet the performance requirements of Federal Specification RR-C-271F Type IVA, Grade A, Class 1, except for those provisions required of the contractor. For additional information, see page 452.



**G-215/S-215**

G-215 Round pin chain shackles meet the performance requirements of Federal Specification RR-C-271F Type IVB, Grade A, Class 1, except for those provisions required of the contractor. For additional information, see page 476.

- Capacities 1/2 through 35 metric tons.
- Forged - Quenched and Tempered, with alloy pins.
- Working Load Limit permanently shown on every shackle.
- Hot Dip galvanized or self colored.
- Fatigue rated.
- Shackles 25t and larger are **RFID EQUIPPED**.
- Shackles can be furnished proof tested with certificates to designated standards, such as ABS, DNV, Lloyds, or other certification. Charges for proof testing and certification available when requested at the time of order.
- Shackles are Quenched and Tempered and can meet DNV impact requirements of 42 joules (31 ft-lbs.) at -20 degrees C (-4 degrees F).
- Look for the Red Pin® . . . the mark of genuine Crosby quality.

Load Rated Fatigue Rated



QUIC-CHECK®



MAXTOUGH®



**SEE APPLICATION INFORMATION**

On Page 92 of the General Catalog  
Para Español: www.thecrosbygroup.com

**G-213 / S-213 Round Pin Anchor Shackles**

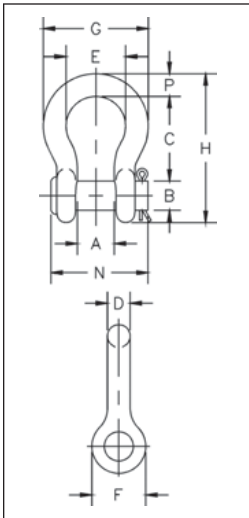

Nominal Size (in.)	Working Load Limit (t)*	Stock No.		Weight Each (kg)	Dimensions (mm)										Tolerance + / -	
		G-213	S-213		A	B	C	D	E	F	G	H	N	P	C	A
1/4	1/2	1018017	1018026	.06	11.9	7.85	28.7	6.35	19.8	15.5	32.5	46.7	34.0	6.35	1.50	1.50
5/16	3/4	1018035	1018044	.08	13.5	9.65	31.0	7.85	21.3	19.1	37.3	53.0	40.4	7.85	1.50	1.50
3/8	1	1018053	1018062	.13	16.8	11.2	36.6	9.65	26.2	23.1	45.2	63.0	47.2	9.65	3.30	1.50
7/16	1-1/2	1018071	1018080	.17	19.1	12.7	42.9	11.2	29.5	26.9	51.5	74.0	54.0	11.2	3.30	1.50
1/2	2	1018099	1018106	.32	20.6	16.0	47.8	12.7	33.3	30.2	58.5	83.5	60.5	12.7	3.30	1.50
5/8	3-1/4	1018115	1018124	.68	26.9	19.1	60.5	16.0	42.9	38.1	74.5	106	74.0	17.5	3.30	1.50
3/4	4-3/4	1018133	1018142	1.05	31.8	22.4	71.5	19.1	51.0	46.0	89.0	126	87.0	20.6	6.35	1.50
7/8	6-1/2	1018151	1018160	1.58	36.6	25.4	84.0	22.4	58.0	53.0	102	148	96.5	24.6	6.35	1.50
1	8-1/2	1018179	1018188	2.27	42.9	28.7	95.5	25.4	68.5	60.5	119	167	115	26.9	6.35	1.50
1-1/8	9-1/2	1018197	1018204	3.16	46.0	31.8	108	28.7	74.0	68.5	131	190	130	31.8	6.35	1.50
1-1/4	12	1018213	1018222	4.42	51.5	35.1	119	32.8	82.5	76.0	146	210	140	35.1	6.35	1.50
1-3/8	13-1/2	1018231	1018240	6.01	57.0	38.1	133	36.1	92.0	84.0	162	233	156	38.1	6.35	3.30
1-1/2	17	1018259	1018268	7.82	60.5	41.4	146	39.1	98.5	92.0	175	254	165	41.1	6.35	3.30
1-3/4	25	1018277	1018286	13.4	73.0	51.0	178	46.7	127	106	225	313	197	57.0	6.35	3.30
2	35	1018295	1018302	20.8	82.5	57.0	197	53.0	146	122	253	348	222	61.0	6.35	3.30

\* NOTE: Maximum Proof Load is 2.0 times the Working Load Limit. Minimum Ultimate Strength is 6 times the Working Load Limit. For Working Load Limit reduction due to side loading applications, see page 94.

**G-215 / S-215 Round Pin Chain Shackles**

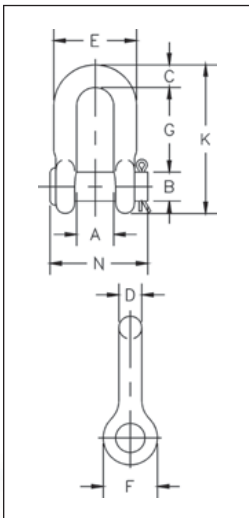

Nominal Size (in.)	Working Load Limit (t)*	Stock No.		Weight Each (kg)	Dimensions (mm)										Tolerance + / -	
		G-215	S-215		A	B	C	D	E	F	G	K	N	G	A	
1/4	1/2	1018810	1018829	.05	11.9	7.85	6.35	6.35	24.6	15.5	22.4	40.4	34.0	1.50	1.50	
5/16	3/4	1018838	1018847	.08	13.5	9.65	7.85	7.85	29.5	19.1	26.2	48.5	40.4	1.50	1.50	
3/8	1	1018856	1018865	.11	16.8	11.2	9.65	9.65	35.8	23.1	31.8	58.5	47.2	3.30	1.50	
7/16	1-1/2	1018874	1018883	.18	19.1	12.7	11.2	11.2	41.4	26.9	36.6	67.5	54.0	3.30	1.50	
1/2	2	1018892	1018909	.23	20.6	16.0	12.7	12.7	46.0	30.2	41.4	77.0	60.5	3.30	1.50	
5/8	3-1/4	1018918	1018927	.55	26.9	19.1	15.7	16.0	58.5	38.1	51.0	95.5	74.0	3.30	1.50	
3/4	4-3/4	1018936	1018945	.91	31.8	22.4	20.6	19.1	70.0	46.0	60.5	115	87.0	6.35	1.50	
7/8	6-1/2	1018954	1018963	1.49	36.6	25.4	24.6	22.4	81.0	53.0	71.5	135	96.5	6.35	1.50	
1	8-1/2	1018972	1018981	2.15	42.9	28.7	25.4	25.4	93.5	60.5	81.0	151	115	6.35	1.50	
1-1/8	9-1/2	1018990	1019007	2.86	46.0	31.8	31.8	28.7	103	68.5	91.0	172	130	6.35	1.50	
1-1/4	12	1019016	1019025	4.08	51.5	35.1	35.1	31.8	115	76.0	100	191	140	6.35	3.30	
1-3/8	13-1/2	1019034	1019043	5.44	57.0	38.1	38.1	35.1	127	84.0	111	210	156	6.35	3.30	
1-1/2	17	1019052	1019061	7.33	60.5	41.4	41.1	38.1	137	92.0	122	230	165	6.35	3.30	
1-3/4	25	1019070	1019089	13.6	73.0	51.0	54.0	44.5	162	106	146	279	197	6.35	3.30	
2	35	1019098	1019105	19.6	82.5	57.0	51.0	53.3	184	122	172	312	222	6.35	3.30	

\* NOTE: Maximum Proof Load is 2.0 times the Working Load Limit. Minimum Ultimate Strength is 6 times the Working Load Limit. For Working Load Limit reduction due to side loading applications, see page 94.



# Crosby® Screw Pin Shackles



**G-209/S-209**

G-209 Screw pin anchor shackles meet the performance requirements of Federal Specification RR-C-271F Type IVA, Grade A, Class 2, except for those provisions required of the contractor. For additional information, see page 452.

- Capacities 1/3 thru 55 metric tons, grade 6.
- Forged - Quenched and Tempered, with alloy pins.
- Working Load Limit and grade "6" permanently shown on every shackle.
- Hot Dip galvanized or self colored.
- Fatigue rated.
- Shackles 25t and larger are **RFID EQUIPPED**.
- Shackles can be furnished proof tested with certificates to designated standards, such as ABS, DNV, Lloyds, or other certification. Proof testing and certification available when requested at the time of order, charges will apply.
- Approved for use at -40 degrees C (-40 degrees F) to 204 degrees C (400 degrees F).
- 3.25t through 25t G209 anchor shackles are type approved to DNV Certification Notes 2.7-1- Offshore Containers. These shackles are statistical proof and impact tested to 42 joules (31 ft-lbs.) min. avg. at -20 degrees C (-4 degrees F). The tests are conducted by Crosby and 3.1 test certification is available upon request.
- All other 209 and all 210 shackles can meet charpy requirements of 42 joules(31 ft-lbs) avg. at -20 degrees C (-4 degrees F) upon special request.
- Meets or exceeds all requirements of ASME B30.26.
- Type Approval and certification in accordance with ABS 2006 Steel Vessel Rules 1-1-17.7, and ABS Guide for Certification of Cranes.
- Crosby 3.25t through 25t G209 anchor shackles are type approved to DNV Certification Notes 2.7-1 - Offshore Containers. These Crosby shackles are statistical proof and impact tested. The tests are conducted by Crosby and 3.1 test certification is available upon request.
- Look for the Red Pin®... the mark of genuine Crosby quality.



**G-210/S-210**

G-210 Screw pin anchor shackles meet the performance requirements of Federal Specification RR-C-271F Type IVA, Grade A, Class 2, except for those provisions required of the contractor. For additional information, see page 452.



**SEE APPLICATION INFORMATION**  
On Page 92 of the General Catalog  
Para Español: www.thecrosbygroup.com

## G-209 / S-209 Screw Pin Anchor Shackles

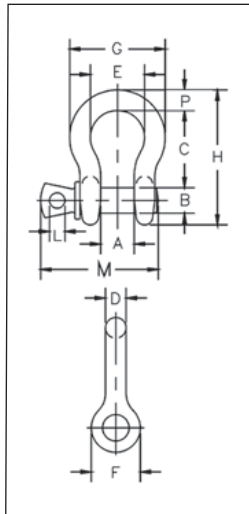

Nominal Size (in.)	Working Load Limit (t)*	Stock No.		Weight Each (kg)	Dimensions (mm)													Tolerance +/-	
		G-209	S-209		A	B	C	D	E	F	G	H	L	M	P	C	A		
3/16	1/3	1018357	-	.03	9.65	6.35	22.4	4.85	15.2	14.2	24.9	37.3	4.06	28.4	4.85	1.50	1.50		
1/4	1/2	1018375	1018384	.05	11.9	7.85	28.7	6.35	19.8	15.5	32.5	46.7	4.85	35.1	6.35	1.50	1.50		
5/16	3/4	1018393	1018400	.09	13.5	9.65	31.0	7.85	21.3	19.1	37.3	53.0	5.60	42.2	7.85	3.30	1.50		
3/8	1	1018419	1018428	.14	16.8	11.2	36.6	9.65	26.2	23.1	45.2	63.0	6.35	51.5	9.65	3.30	1.50		
7/16	1-1/2	1018437	1018446	.17	19.1	12.7	42.9	11.2	29.5	26.9	51.5	74.0	7.85	60.5	11.2	3.30	1.50		
1/2	2	1018455	1018464	.33	20.6	16.0	47.8	12.7	33.3	30.2	58.5	83.5	9.65	68.5	12.7	3.30	1.50		
5/8	3-1/4	1018473	1018482	.62	26.9	19.1	60.5	16.0	42.9	38.1	74.5	106	11.2	85.0	17.5	6.35	1.50		
3/4	4-3/4	1018491	1018507	1.07	31.8	22.4	71.5	19.1	51.0	46.0	89.0	126	12.7	101	20.6	6.35	1.50		
7/8	6-1/2	1018516	1018525	1.64	36.6	25.4	84.0	22.4	58.0	53.0	102	148	12.7	114	24.6	6.35	1.50		
1	8-1/2	1018534	1018543	2.28	42.9	28.7	95.5	25.4	68.5	60.5	119	167	14.2	129	26.9	6.35	1.50		
1-1/8	9-1/2	1018552	1018561	3.36	46.0	31.8	108	29.5	74.0	68.5	131	190	16.0	142	31.8	6.35	1.50		
1-1/4	12	1018570	1018589	4.31	51.5	35.1	119	32.8	82.5	76.0	146	210	17.5	156	35.1	6.35	1.50		
1-3/8	13-1/2	1018598	1018605	6.14	57.0	38.1	133	36.1	92.0	84.0	162	233	19.1	174	38.1	6.35	3.30		
1-1/2	17	1018614	1018623	7.80	60.5	41.4	146	39.1	98.5	92.0	175	254	20.6	187	41.1	6.35	3.30		
1-3/4	25	1018632	1018641	12.6	73.0	51.0	178	46.7	127	106	225	313	25.4	231	57.0	6.35	3.30		
2	35	1018650	1018669	20.4	82.5	57.0	197	53.0	146	122	253	348	31.0	263	61.0	6.35	3.30		
2-1/2	55	1018678	1018687	38.9	105	70.0	267	69.0	184	145	327	453	35.1	330	79.5	6.35	6.35		

## G-210 / S-210 Screw Pin Chain Shackles

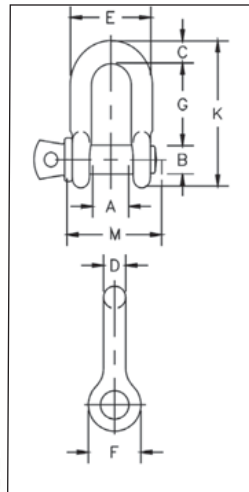

Nominal Size (in.)	Working Load Limit (t)*	Stock No.		Weight Each (kg)	Dimensions (mm)													Tolerance +/-	
		G-210	S-210		A	B	C	D	E	F	G	K	L	M	G	A			
1/4	1/2	1019150	1019169	.05	11.9	7.85	6.35	6.35	24.6	15.5	22.4	40.4	4.85	35.1	1.50	1.50			
5/16	3/4	1019178	1019187	.08	13.5	9.65	7.85	7.85	29.5	19.1	26.2	48.5	5.60	42.2	1.50	1.50			
3/8	1	1019196	1019203	.13	16.8	11.2	9.65	9.65	35.8	23.1	31.8	58.5	6.35	51.5	3.30	1.50			
7/16	1-1/2	1019212	1019221	.20	19.1	12.7	11.2	11.2	41.4	26.9	36.6	67.5	7.85	60.5	3.30	1.50			
1/2	2	1019230	1019249	.27	20.6	16.0	12.7	12.7	46.0	30.2	41.4	77.0	9.65	68.5	3.30	1.50			
5/8	3-1/4	1019258	1019267	.57	26.9	19.1	15.7	16.0	58.5	38.1	51.0	95.5	11.2	85.0	3.30	1.50			
3/4	4-3/4	1019276	1019285	1.20	31.8	22.4	20.6	19.1	70.0	46.0	60.5	115	12.7	101	6.35	1.50			
7/8	6-1/2	1019294	1019301	1.43	36.6	25.4	24.6	22.4	81.0	53.0	71.5	135	12.7	114	6.35	1.50			
1	8-1/2	1019310	1019329	2.15	42.9	28.7	25.4	25.4	93.5	60.5	81.0	151	14.2	129	6.35	1.50			
1-1/8	9-1/2	1019338	1019347	3.06	46.0	31.8	31.8	28.7	103	68.5	91.0	172	16.0	142	6.35	1.50			
1-1/4	12	1019356	1019365	4.11	51.5	35.1	35.1	31.8	115	76.0	100	191	17.5	156	6.35	3.30			
1-3/8	13-1/2	1019374	1019383	5.28	57.0	38.1	38.1	35.1	127	84.0	111	210	19.1	174	6.35	3.30			
1-1/2	17	1019392	1019409	7.23	60.5	41.4	41.1	38.1	137	92.0	122	230	20.6	187	6.35	3.30			
1-3/4	25	1019418	1019427	12.1	73.0	51.0	54.0	44.5	162	106	146	279	25.4	231	6.35	3.30			
2	35	1019436	1019445	19.2	82.5	57.0	60.0	51.0	184	122	172	312	31.0	263	6.35	3.30			
2-1/2	55	1019454	1019463	32.5	105	70.0	66.5	66.5	238	145	203	377	35.1	330	6.35	6.35			

\* NOTE: Maximum Proof Load is 2.0 times the Working Load Limit. Minimum Ultimate Strength is 6 times the Working Load Limit. For Working Load Limit reduction due to side loading applications, see page 94.

# Crosby® Alloy Screw Pin Shackles



**G-209A**

Screw pin anchor shackles meet the performance requirements of Federal Specification RR-C-271F Type IVA, Grade B, Class 2, except for those provisions required of the contractor. For additional information, see page 452.

- Capacities 2 thru 21 metric tons. Meets performance requirements of Grade 8 shackles.
- Forged Alloy Steel – Quenched and Tempered, with alloy pins.
- Working Load Limit permanently shown on every shackle.
- Hot Dip Galvanized.
- Shackles can be furnished proof tested with certificates to designated standards, such as ABS, DNV, Lloyds, or other certification. Charges for proof testing and certification available when requested at the time of order.
- Approved for use at -40 degree C (-40 degree F) to 204 degree C (400 degree F).
- Meets or exceeds all requirements of ASME B30.26 including identification, ductility, design factor, proof load and temperature requirements. Importantly, these shackles meet other critical performance requirements including impact properties and material traceability, not addressed by ASME B30.26.

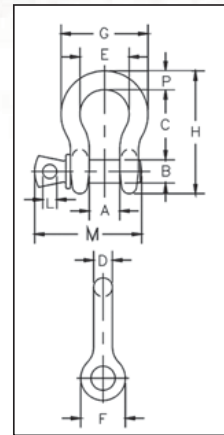

**SEE APPLICATION INFORMATION**

On Page 92 of the General Catalog  
Para Español: www.thecrosbygroup.com

## G-209A Alloy Screw Pin Shackles

Nominal Size (in.)	Working Load Limit (t)*	G-209A Stock No.	Weight Each (kg)	Dimensions (mm)											Tolerance +/-	
				A	B	C	D	E	F	G	H	L	M	P	C	A
3/8	2	1017450	.14	16.8	11.2	36.6	9.65	26.2	23.1	45.2	63.5	6.35	51.5	9.65	3.30	1.50
7/16	2-2/3	1017472	.17	19.1	12.7	42.9	11.2	29.5	26.9	51.5	74.0	7.85	60.5	11.2	3.30	1.50
1/2	3-1/3	1017494	.29	20.6	16.0	47.8	12.7	23.3	30.2	58.5	83.5	9.65	68.5	12.7	3.30	1.50
5/8	5	1017516	.63	26.9	19.1	60.5	16.0	42.9	38.1	74.5	106	11.2	85.0	17.5	3.30	1.50
3/4	7	1017538	1.02	31.8	22.4	71.5	19.1	51.0	46.0	89.0	126	12.7	101	20.6	6.35	1.50
7/8	9-1/2	1017560	1.53	36.6	25.4	84.0	22.4	58.0	53.0	102	148	12.7	114	24.6	6.35	1.50
1	12-1/2	1017582	2.41	42.9	28.7	95.5	25.4	68.5	60.5	119	167	14.2	129	26.9	6.35	1.50
1-1/8	15	1017604	3.09	46.0	31.8	108	29.5	74.0	68.5	131	190	16.0	142	31.8	6.35	1.50
1-1/4	18	1017626	4.31	51.5	35.1	119	32.8	82.5	76.0	146	210	17.5	156	35.1	6.35	1.50
1-3/8	21	1017648	6.01	57.0	38.1	133	36.1	92.0	84.0	162	233	19.1	174	38.1	6.35	3.30

\* Maximum Proof Load is 2 times the Working Load Limit. Minimum Ultimate Load is 4.5 times the Working Load Limit. For Working Load Limit reduction due to side loading applications, see page 94.



**G-2169**



**S-2169**

- Capacities of 7, 12.5 and 18 metric tons.
- Quenched and Tempered for maximum strength.
- Forged Alloy Steel.
- Available in galvanized and self colored finished.
- Individually proof tested and magnetic particle inspected. Crosby certification available at time of order.
- Meets or exceeds all requirements of ASME B30.26 including identification, ductility, design factor, proof load and temperature requirements. Importantly, these shackles meet other critical performance requirements including fatigue life, impact properties and material traceability, not addressed by ASME B30.26.
- Look for the Red Pin® . . . the mark of genuine Crosby quality.

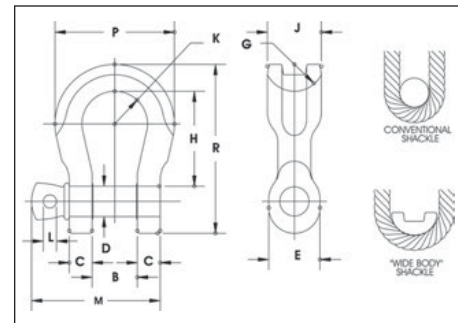

**SEE APPLICATION INFORMATION**

On Page 92 of the General Catalog  
Para Español: www.thecrosbygroup.com

## G-2169 / S-2169 Alloy Screw Pin “Wide Body” Shackles

Working Load Limit (t)*	G-2169 Stock No.	S-2169 Stock No.	Weight Each (kg)	Dimensions (mm)											
				B +/- .25	C	D +/- .02	E	G	H	J	K	L	M	P	R
7	1021655	1021664	7.7	31.8	17.5	22.4	46.2	31.8	90.4	40.6	31.8	12.7	101	104	149
12.5	1021673	1021682	19.4	42.9	23.4	28.7	60.5	34.8	118	54.1	41.4	14.2	130	140	194
18	1021691	1021699	28.7	51.6	29.5	35.1	68.3	38.1	148	63.5	50.8	17.5	159	172	238

\* Ultimate Load is 5 times the Working Load Limit. Proof Load is 2 times the Working Load Limit.



# Crosby® Bolt Type Shackles



## G-2130 / S-2130

Bolt Type Anchor shackles with thin head bolt - nut with cotter pin. Meets the performance requirements of Federal Specification RR-C-271F Type IVA, Grade A, Class 3, except for those provisions required of the contractor. For additional information, see page 452.

- Capacities 1/3 thru 150 metric tons, grade 6.
- Working Load Limit and grade "6" permanently shown on every shackle.
- Forged – Quenched and Tempered, with alloy pins.
- Hot Dip galvanized or self colored. (85, 120, and 150 metric ton shackles are all hot dip galvanized bows and the bolts are Dimetcoated® and painted red)
- Fatigue rated (1/3t - 55t).
- Shackles 25t and larger are **RFID EQUIPPED**.
- Approved for use at -40 degree C (-40 degree F) to 204 degree C (400 degree F).
- Meets or exceeds all requirements of ASME B30.26.
- Shackles 85 metric tons and larger are individually proof tested to 2.0 times the working load limit.
- Type Approval and certification in accordance with ABS 2011 Steel Vessel Rules 1-1-17.7, and ABS Guide for Certification of Cranes.
- 3.1 Certification as standard available for charpy and statistical proof test for pg 79 only up to 25 tons to DNV2.7-1 and EN13889.
- Crosby 3.25t through 25t G2130OC anchor shackles are type approved to DNV Certification Notes 2.7-1- Offshore Containers. These Crosby shackles are statistical proof and impact tested to 42 joules (31 ft.-lbs.) min. avg. at -20 degrees C (-4 degrees F). The tests are conducted by Crosby and 3.1 test certification is available upon request. Refer to page 88 for Crosby COLD TUFF® shackles that meet the additional requirements of DNV rules for certification of lifting applications - Loose Gear.
- All other 2130 shackles can meet charpy requirements of 42 joules (31 ft.-lbs) avg at -20 degrees C (-4 degrees F) upon special request.
- Look for the Red Pin® . . . the mark of genuine Crosby quality.

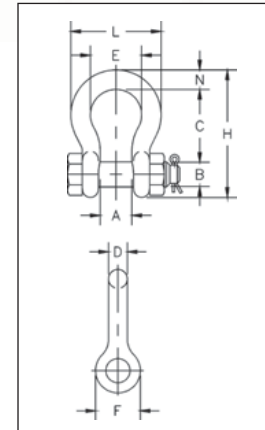

**SEE APPLICATION INFORMATION**  
On Page 92 of the General Catalog  
Para Español: [www.thecrosbygroup.com](http://www.thecrosbygroup.com)

## G-2130 / S-2130 Bolt Type Anchor Shackles

Nominal Size (in.)	Working Load Limit (t)*	Stock No.			Weight Each (kg)	Dimensions (mm)										Tolerance +/-	
		G-2130	S-2130	G-2130OC		A	B	C	D	E	F	H	L	N	C	A	
3/16	1/3 ‡	1019464	–	–	.03	9.65	6.35	22.4	4.85	15.2	14.2	37.3	24.9	4.85	1.50	1.50	
1/4	1/2	1019466	–	–	.05	11.9	7.85	28.7	6.35	19.8	15.5	46.7	32.5	6.35	1.50	1.50	
5/16	3/4	1019468	–	–	.10	13.5	9.65	31.0	7.85	21.3	19.1	53.0	37.3	7.85	1.50	1.50	
3/8	1	1019470	–	–	.15	16.8	11.2	36.6	9.65	26.2	23.1	63.0	45.2	9.65	3.30	1.50	
7/16	1-1/2	1019471	–	–	.22	19.1	12.7	42.9	11.2	29.5	26.9	74.0	51.5	11.2	3.30	1.50	
1/2	2	1019472	1019481	–	.36	20.6	16.0	47.8	12.7	33.3	30.2	83.5	58.5	12.7	3.30	1.50	
5/8	3-1/4	1019490	1019506	1262013	.62	26.9	19.1	60.5	16.0	42.9	38.1	106	74.5	17.5	3.30	1.50	
3/4	4-3/4	1019515	1019524	1262022	1.23	31.8	22.4	71.5	19.1	51.0	46.0	126	89.0	20.6	6.35	1.50	
7/8	6-1/2	1019533	1019542	1262031	1.79	36.6	25.4	84.0	22.4	58.0	53.0	148	102	24.6	6.35	1.50	
1	8-1/2	1019551	1019560	1262040	2.28	42.9	28.7	95.5	25.4	68.5	60.5	167	119	26.9	6.35	1.50	
1-1/8	9-1/2	1019579	1019588	1262059	3.75	46.0	31.8	108	28.7	74.0	68.5	190	131	31.8	6.35	1.50	
1-1/4	12	1019597	1019604	1262068	5.31	51.5	35.1	119	31.8	82.5	76.0	210	146	35.1	6.35	1.50	
1-3/8	13-1/2	1019613	1019622	1262077	7.18	57.0	38.1	133	35.1	92.0	84.0	233	162	38.1	6.35	3.30	
1-1/2	17	1019631	1019640	1262086	8.62	60.5	41.4	146	38.1	98.5	92.0	254	175	41.1	6.35	3.30	
1-3/4	25	1019659	1019668	1262095	15.4	73.0	51.0	178	44.5	127	106	313	225	57.0	6.35	3.30	
2	35	1019677	1019686	–	23.7	82.5	57.0	197	51.0	146	122	348	253	61.0	6.35	3.30	
2-1/2	55	1019695	1019702	–	44.6	105	70.0	267	66.5	184	145	453	327	79.5	6.35	6.35	
3	† 85	1019711	–	–	70	127	82.5	330	76.0	200	165	546	365	92.0	6.35	6.35	
3-1/2	† 120 ‡	1019739	–	–	120	133	95.5	372	92.0	229	203	626	419	105	6.35	6.35	
4	† 150 ‡	1019757	–	–	153	140	108	368	104	254	229	653	468	116	6.35	6.35	

\* NOTE: Maximum Proof Load is 2.0 times the Working Load Limit. Minimum Ultimate Strength is 6 times the Working Load Limit. For Working Load Limit reduction due to side loading applications, see page 94. † Individually Proof Tested with certification. ‡ Furnished in Anchor style only and furnished with Round Head Bolts with welded handles.

**SHACKLES**



**G-2150 / S-2150**

Bolt Type chain shackles with thin hex head bolt - nut with cotter pin. Meets the performance requirements of Federal Specification RR-C-271F Type IVA, Grade A, Class 3, except for those provisions required of the contractor. For additional information, see page 452.

- Capacities 1/2 thru 85 metric tons, grade 6.
- Working Load Limit and grade "6" permanently shown on every shackle.
- Forged — Quenched and Tempered, with alloy pins.
- Hot Dip galvanized or self colored. (85, 120, and 150-metric ton shackles are all hot dip galvanized bows and the bolts are Dimetcoated® and painted red)
- Fatigue rated (1/2t - 55t).
- Shackles 25t and larger are **RFID EQUIPPED**.
- Approved for use at -40 degrees C (-40 degrees F) to 204 degrees C (400 degrees F).
- 3.25t through 25t bow and bolt are certified to meet charpy impact testing of 42 joules (31 ft-lbs.) min. avg. at -20 degrees C (-4 degrees F)
- Meets or exceeds all requirements of ASME B30.26.
- Sizes 1/2 - 25t meet the performance requirements of EN13889:2003.
- Shackles 55 metric tons and smaller can be furnished proof tested with certificates to designated standards, such as ABS, DNV, Lloyds, or other certification when requested at time of order.
- Type Approval and certification in accordance with ABS 2006 Steel Vessel Rules 1-1-17.7, and ABS Guide for Certification of Cranes.
- All 2150 shackles can meet charpy requirements of 42 joules (31 ft-lbs) avg at -20 degree C (-4 degrees F) upon special request.
- Look for the Red Pin® . . . the mark of genuine Crosby quality.

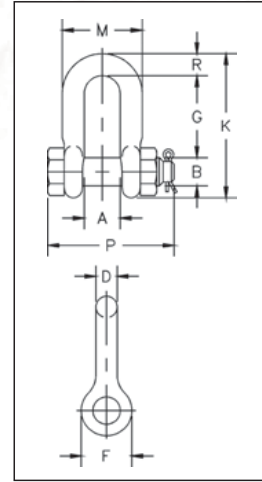

**SEE APPLICATION INFORMATION**  
On Page 92 of the General Catalog  
Para Español: [www.thecrosbygroup.com](http://www.thecrosbygroup.com)

**G-2150 / S-2150 Bolt Type Chain Shackles**

Nominal Size (in.)	Working Load Limit (t)*	Stock No.		Weight Each (kg)	Dimensions (mm)										Tolerance +/-	
		G-2150	S-2150		A	B	D	F	G	K	M	P	R	G	A	
1/4	1/2	1019768	-	.06	11.9	7.85	6.35	15.5	19.1	40.4	24.6	39.6	6.35	1.50	1.50	
5/16	3/4	1019770	-	.10	13.5	9.65	7.85	19.1	25.4	48.5	29.5	46.2	7.85	1.50	1.50	
3/8	1	1019772	-	.15	16.8	11.2	9.65	23.1	31.0	58.5	35.8	55.0	9.65	3.30	1.50	
7/16	1-1/2	1019774	-	.22	19.1	12.7	11.2	26.9	36.1	67.5	41.1	63.5	11.2	3.30	1.50	
1/2	2	1019775	1019784	.34	20.6	16.0	12.7	30.2	41.4	77.0	46.0	71.0	12.7	3.30	1.50	
5/8	3-1/4	1019793	1019800	.67	26.9	19.1	16.0	38.1	51.0	95.5	58.5	89.5	16.0	3.30	1.50	
3/4	4-3/4	1019819	1019828	1.14	31.8	22.4	19.1	46.0	60.5	115	70.0	103	20.6	6.35	1.50	
7/8	6-1/2	1019837	1019846	1.74	36.6	25.4	22.4	53.0	71.5	135	81.0	120	24.6	6.35	1.50	
1	8-1/2	1019855	1019864	2.52	42.9	28.7	25.4	60.5	81.0	151	93.5	135	25.4	6.35	1.50	
1-1/8	9-1/2	1019873	1019882	3.45	46.0	31.8	28.7	68.5	91.0	172	103	150	31.8	6.35	1.50	
1-1/4	12	1019891	1019908	4.90	51.5	35.1	31.8	76.0	100	191	115	165	35.1	6.35	1.50	
1-3/8	13-1/2	1019917	1019926	6.24	57.0	38.1	35.1	84.0	111	210	127	183	38.1	6.35	3.30	
1-1/2	17	1019935	1019944	8.39	60.5	41.4	38.1	92.0	122	230	137	196	41.1	6.35	3.30	
1-3/4	25	1019953	1019962	14.2	73.0	51.0	44.5	106	146	279	162	230	54.0	6.35	3.30	
2	35	1019971	1019980	21.2	82.5	57.0	51.0	122	172	312	184	264	60.0	6.35	3.30	
2-1/2	55	1019999	1020004	38.6	105	70.0	66.5	145	203	377	238	344	66.5	6.35	6.35	
3	† 85	1020013	-	56	127	82.5	76.0	165	216	429	279	419	89.0	6.35	6.35	

\* NOTE: Maximum Proof Load is 2.0 times the Working Load Limit. Minimum Ultimate Strength is 6 times the Working Load Limit. For Working Load Limit reduction due to side loading applications, see page 94. † Individually Proof Tested with certification. ‡ Furnished in Anchor style only and furnished with Round Head Bolts with welded handles.



# Crosby® Bolt Type Shackles



**G-2130A**

Bolt Type Anchor shackles with thin head bolt – nut with cotter pin. Meets the performance requirements of Federal Specification RR-C-271F Type IVA, Grade B, Class 3, except for those provisions required of the contractor. For additional information, see page 452.

- Capacities 2 to 17 metric tons.
- Working Load Limit permanently shown on every shackle.
- Forged Alloy Steel – Quenched and Tempered, with bow and bolt.
- Hot Dip galvanized.
- Shackles can be **RFID EQUIPPED**.
- Meets or exceeds all requirements of ASME B30.26 including identification, ductility, design factor, proof load and temperature requirements. Importantly, G-2130A meet other critical performance requirements including impact properties and material traceability, not addressed by ASME B30.26.
- Shackles can be furnished proof tested with certificates to designated standards, such as ABS, DNV, Lloyds, or other certification when requested at time of order.
- Type Approval and certification in accordance with DNV Type Approval under DNV 2.7-1.
- Shackles are Quenched and Tempered and meet DNV impact requirements of 42 joules (31 ft.-lbs.) at -40 degrees C (-40 degrees F).

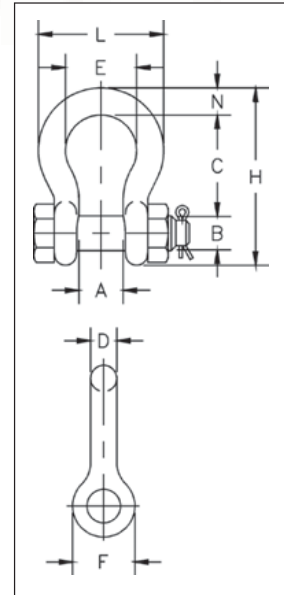

**SEE APPLICATION INFORMATION**  
On Page 92 of the General Catalog  
Para Español: [www.thecrosbygroup.com](http://www.thecrosbygroup.com)

## G-2130A Alloy Bolt Bolt Type Shackles Grade 8

Nominal Size (in.)	Working Load Limit (t)*	G-2130A Stock No.	Weight Each (kg)	Dimensions (mm)										Tolerance +/-	
				A	B	C	D	E	F	H	L	N	C	A	
1/2	2	1219472	.36	20.6	16.0	47.8	12.7	33.3	30.2	83.5	58.5	12.7	3.30	1.50	
5/8	3-1/4	1219491	.62	26.9	19.1	60.5	16.0	42.9	38.1	106	74.5	17.5	6.35	1.50	
3/4	4-3/4	1219516	1.23	31.8	22.4	71.5	19.1	51.0	46.0	126	89.0	20.6	6.35	1.50	
7/8	6-1/2	1219534	1.79	36.6	25.4	84.0	22.4	58.0	53.0	148	102	24.6	6.35	1.50	
1	8-1/2	1219552	2.28	42.9	28.0	95.5	25.4	68.5	60.5	167	119	26.9	6.35	1.50	
1-1/8	9-1/2	1219578	3.75	46.0	31.8	108	28.7	74.0	68.5	190	131	31.8	6.35	1.50	
1-1/4	12	1219598	5.31	51.5	35.1	119	31.8	82.5	76.0	210	146	35.1	6.35	1.50	
1-3/8	13-1/2	1219614	7.18	57.0	38.1	133	35.1	92.0	84.0	233	162	38.1	6.35	3.30	
1-1/2	17	1219632	8.62	60.5	41.4	146	38.1	98.5	92.0	254	175	41.1	6.35	3.30	

\* NOTE: Maximum Proof Load is 2.0 times the Working Load Limit. Minimum Ultimate Strength is 8 times the Working Load Limit. For Working Load Limit reduction due to side loading applications, see page 94.



### Testing the Limits

In 2013, Sir Ranulph Fiennes and five colleagues set out to test the limits of human endurance and achieve the feat of becoming the first individuals to cross the continent of Antarctica in winter. As a proud partner in this endeavor, Crosby provided its full range of COLD TUFF® products, which are specifically manufactured to function in extreme environments such as those encountered throughout the expedition—including temperatures as low as -90° C.



**SHACKLES**



**G-2140 / S-2140**

G-2140 meets the performance requirements of Federal Specification RR-C-271F, Type IVA, Grade B, Class 3, except for those provisions required of the contractor. For additional information, see page 452.

- Quenched and Tempered.
- Alloy bows, Alloy bolts.
- Forged Alloy Steel 2 thru 200 metric tons. Cast Alloy Steel 250 thru 400 metric tons. Meets performance requirements of Grade 8 shackles.
- Working Load Limit is permanently shown on every shackle.
- 30, 40, 55, and 85 metric ton shackle bows are available galvanized or self colored with pins that are galvanized and painted red.
- 120, 150, 175 metric ton shackle bows are hot-dip galvanized; bolts are Dimetcoted® and painted red.
- 400 metric ton shackle bows are Dimetcoted®; bolts are Dimetcoted® and painted red.
- Sizes 1-1/2 and larger are **RFID EQUIPPED**.
- Approved for use at -40 degrees C (-40 degrees F) to 204 degrees C (400 degrees F).
- Shackles are Quenched and Tempered and can meet DNV impact requirements of 42 joules (31 ft-lbs.) at -20 degrees C (-4 degrees F).
- All sizes are individually proof tested if requested at time of order, to 2.0 times the Working Load Limit.
- Refer to page 88 for Crosby COLD TUFF® shackles that meet the additional requirements of DNV rules for certification of lifting applications - Loose Gear.
- Shackles 200 metric tons and larger are provided as follows.
  - Serialized pin and bow
  - Material certification (chemical)
  - Magnetic particle inspected.
  - Certification must be requested at time of order.
- Meets or exceeds all requirements of ASME B30.26 including identification, ductility, design factor, proof load and temperature requirements. 2140 shackles meet other critical performance requirements including impact properties and material traceability, not addressed by ASME B30.26.
- Type Approval and certification in accordance with ABS 2006 Steel Vessel Rules 1-1-17.7, and ABS Guide for Certification of Cranes.
- Look for the Red Pin® . . . the mark of genuine Crosby quality.

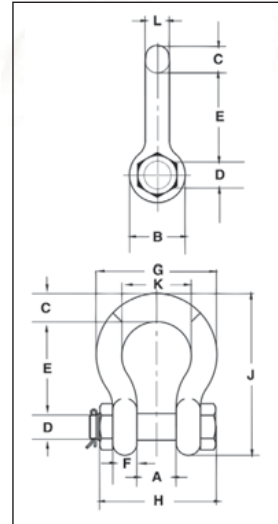

**SEE APPLICATION INFORMATION**

On Page 92 of the General Catalog  
Para Español: [www.thecrosbygroup.com](http://www.thecrosbygroup.com)

## G-2140 / S-2140 Crosby® Alloy Bolt Type Anchor Shackles

Nominal Shackle Size (in.)	Working Load Limit (t)*	Stock No.		Weight Each (kg)	Dimensions (mm)											Tolerance + / -	
		G-2140	S-2140		A	B	C	D +/- .5	E	F	G	H	J	K	L	A	E
3/8	2	1021015	-	0.15	16.8	23.1	9.7	11.2	36.6	9.7	45.2	55.1	63.2	26.2	9.7	1.5	3.3
7/16	2 2/3	1021020	-	0.22	19.1	26.9	11.2	12.7	42.9	10.4	51.6	63.8	73.9	29.5	11.2	1.5	3.3
1/2	3 1/3	1021029	-	0.36	20.6	30.2	12.7	16.3	47.8	11.7	58.7	71.1	83.3	33.3	12.7	1.5	3.3
5/8	5	1021038	-	0.76	26.9	38.1	17.5	19.6	60.5	14.7	74.7	90.4	106.4	42.9	16.0	1.5	3.3
3/4	7	1021047	-	1.23	31.8	46.0	20.6	22.6	71.4	17.5	88.9	105.4	126.2	50.8	19.1	1.5	6.4
7/8	9 1/2	1021056	-	1.79	36.6	53.1	24.6	25.9	84.1	20.6	102.4	122.4	148.1	57.9	22.4	1.5	6.4
1	12 1/2	1021065	-	2.57	42.9	60.5	26.9	29.2	95.3	23.4	119.1	136.9	166.6	68.3	25.4	1.5	6.4
1 1/8	15	1021074	-	3.75	46.0	68.3	31.8	31.8	108.0	26.4	131.1	149.9	189.7	73.9	28.7	1.5	6.4
1 1/4	18	1021083	-	5.31	51.6	76.2	35.1	35.6	119.1	29.5	146.1	169.9	209.6	82.6	32.8	1.5	6.4
1 3/8	21	1021092	-	7.18	57.2	84.1	38.1	38.9	133.4	32.5	162.1	183.1	232.7	92.2	36.1	3.3	6.4
1-1/2	30	1021110	1021129	8.52	60.5	91.9	41.1	41.4	146	35.3	175	196	254	98.6	38.9	3.3	6.4
1-3/4	40	1021138	1021147	15.4	73.2	106	57.2	50.8	178	44.5	224	237	313	127	46.7	3.3	6.4
2	55	1021156	1021165	23.6	82.6	122	61.0	57.2	197	50.8	258	264	347	146	52.8	3.3	6.4
2-1/2	85	1021174	1021183	43.5	105	148	79.2	69.9	267	66.5	324	345	455	184	68.8	6.4	6.4
3	120	1021192	-	81	127	165	92.2	82.6	330	76.2	371	384	546	200	79.2	6.4	6.4
3-1/2	† 150	1021218	-	120	133	203	111	95.3	372	95.3	432	448	632	229	91.9	6.4	6.4
4	† 200	1021236	-	153	140	229	116	108	368	102	457	517	652	254	102	6.4	6.4
4 3/4	† 200	1021234	-	209	184	267	127	121	386	116	529	611	706	279	121	6.35	6.35
5	† 250	1021443	-	276	216	305	143	127	470	123	600	632	828	330	127	4.0	1.80
6	† 300	1021252	-	362	213	330	154	152	475	124	629	666	871	330	149	4.0	1.80
7**	† 400	1021478	-	500	210	356	184	178	572	165	660	728	1022	330	152	6.4	6.4

\* Note: Maximum Proof Load is 2.0 times the Working Load Limit. Minimum Ultimate Load is 4.5 times the Working Load Limit on 2 thru 21 metric tons. For sizes 30 thru 175 metric tons, Minimum Ultimate Load is 5.4 times the Working Load Limit for 200 thru 400 metric tons, Minimum Ultimate Load is 4 times the Working Load Limit. \*\* Cast Alloy Steel.  
† Furnished with Round Head Bolts with an eyebolt for handling. For Working Load Limit reduction due to side loading applications, see page 94.



# Crosby® Alloy Easy-Loc® Shackles



## G-2140E

G-2140E meets the performance requirements of Federal Specification RR-C-271F, Type IVA, Grade B, Class 3, except for those provisions required of the contractor. For additional information, see page 452.

- Quenched and Tempered.
- Alloy bows, Alloy bolts.
- Forged Alloy Steel 200 thru 300 metric tons. Meets performance requirements of Grade 8 shackles.
- Working Load Limit is permanently shown on every shackle.
- 200, 250, and 300 metric ton shackle bows are Dimetcoted®; pins are Dimetcoted® and painted red.
- Sizes 1-1/2 and larger are **RFID EQUIPPED**.
- Approved for use at -40 degrees C (-40 degrees F) to 204 degrees C (400 degrees F).
- Shackles are Quenched and Tempered and can meet DNV impact requirements of 42 joules (31 ft-lbs.) at -20 degree C (-4 degree F).
- All sizes are individually proof tested to 2.0 times the Working Load Limit.
- Refer to page 88 for Crosby COLD TUFF® shackles that meet the additional requirements of DNV rules for certification of lifting applications - Loose Gear.
- Shackles are provided as follows:
  - Serialized pin and bow
  - Material certification (chemical)
  - Magnetic particle inspected.
  - Certification must be requested at time of order.
- Meets or exceeds all requirements of ASME B30.26 including identification, ductility, design factor, proof load and temperature requirements. Importantly, these shackles meet other critical performance requirements including impact properties and material traceability, not addressed by ASME B30.26.
- Type Approval and certification in accordance with ABS 2006 Steel Vessel Rules 1-1-17.7, and ABS Guide for Certification of Cranes.
- Look for the Red Pin® . . . the mark of genuine Crosby quality.

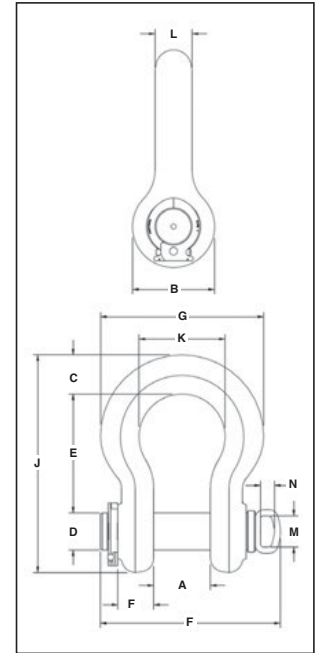

Load Rated



**SEE APPLICATION INFORMATION**

On Page 92 of the General Catalog  
Para Español: [www.thecrosbygroup.com](http://www.thecrosbygroup.com)

## G-2140E Crosby® Alloy Easy-Loc Shackles

Nominal Shackle Size (in.)	Working Load Limit (t)*	Stock No.		Weight Each (kg)	Dimensions (mm)													Tolerance +/-	
		G-2140E	S-2140E		A	B	C	D +/- .5	E	F	G	H	J	K	L	M	N	A	E
4-3/4	† 200	1021422	–	209	184	267	127	121	386	116	529	587	706	279	121	101	45.7	6.4	6.4
5	† 250	1021442	–	276	216	305	143	127	470	114	600	617	829	330	127	101	45.7	6.4	6.4
6	† 300	1021460	–	362	213	330	154	152	475	124	629	646	871	330	149	101	45.7	6.4	6.4

\* Note: Maximum Proof Load is 2.0 times the Working Load Limit. Minimum Ultimate Load is 4 times the Working Load Limit on 200 thru 300 metric Tons. † Furnished with Round Head Bolts with an eyebolt for handling. For Working Load Limit reduction due to side loading applications, see page 94.

**SHACKLES**



**G-2160 / S-2160**

- All sizes Quenched and Tempered for maximum strength.
- Forged alloy steel from 7 through 300 metric tons.
- Cast alloy steel from 400 through 1550 metric tons.
- Sizes 300 metric tons and smaller are proof tested to 2 times the Working Load Limit.
- Sizes 400 metric tons and larger are tested to 1.33 times Working Load Limit.
- All ratings are in metric tons, embossed on side of bow.
- G-2160, (7-55t), are Hot Dip Galvanized and pins are painted red.
- G-2160, (75t and larger), bows are furnished Dimetcoated, and pins are Dimetcoated, then painted red.
- S-2160 bows and pins are painted red.
- Shackles, 30t and larger, are **RFID EQUIPPED**.
- Can be used to connect Synthetic Web Slings, Synthetic Round Slings or Wire Rope Slings.
- Increase in shackle bow radius provides minimum 58% gain in sling bearing surface and eliminates need for a thimble.
- Increases usable sling strength minimum of 15% and greatly improves life of wire rope slings.
- Approved for use at -40 degrees C (-40 degrees F) to 204 degrees C (400 degrees F).
- Bow and bolt are certified to meet Charpy impact testing of 42 joules (31 ft-lbs.) min. avg. at -20 degree C (-4 degree F).
- All 2160 shackles are individually proof tested and magnetic particle inspected. Crosby certification available at time of order.
- Shackles requiring ABS, Lloyds and other certifications are available upon special request and must be specified at time of order.
- Type approved and certification to DNV Rules for Certification of Lifting Appliances, and are produced in accordance with DNV MSA requirements. Databook is provided that includes required documents.
  - Serialization / Identification
  - Material Testing (Physical / Chemical / Charpy)
  - Proof Testing
- Look for the Red Pin® . . . the mark of genuine Crosby quality.

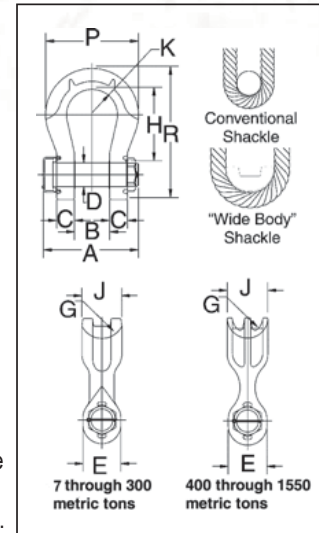

**SEE APPLICATION INFORMATION**

On Page 92 of the General Catalog  
Para Español: [www.thecrosbygroup.com](http://www.thecrosbygroup.com)

## G-2160 / S-2160 Crosby® “Wide Body” Shackles

Working Load Limit (t)*	Stock No.		Weight Each (kg)	Dimensions (mm)											Effective Body Diameter
	G-2160	S-2160		A	B +/- 6.35	C	D +/- .5	E	G	H	J	K	P	R	
7	1021256	1021548	1.81	105	31.8	17.5	22.4	46.2	31.8	90.4	40.6	31.8	104	149	53.3
12.5	1021265	1021557	4.54	137	42.9	23.4	28.7	60.5	34.8	118	54.1	41.4	140	194	61.0
18	1021274	1021566	6.80	170	51.6	29.5	35.1	68.3	38.1	148	63.5	50.8	172	238	71.1
30	1021283	1021575	11.34	195	60.2	35.1	41.4	88.9	63.5	176	79.5	63.5	216	289	104
40	1021285	1021584	20.9	236	73.2	42.9	50.8	102	44.4	205	95.3	76.2	270	346	91.4
55	1021287	1021593	32.21	263	82.6	50.8	57.2	118	66.8	238	114	88.9	311	397	109
75	1021290	-	45	365	105	53.8	69.9	127	89.0	293	121	92.5	312	468	125
125	1022110	-	88.5	465	130	67.6	80.0	165	95.3	365	150	110	393	584	173
200	1022118	-	191	538	150	74.7	105	214	133	480	219	138	515	773	241
300	1022127	-	365	615	187	97.5	133	267	156	600	264	160	608	957	290
400	1021334	-	500	772	220	131	160	320	203	575	320	185	690	985	363
500	1021343	-	650	849	250	146	180	340	205	630	340	225	790	1085	376
600	1021352	-	860	916	275	158	200	394	330	700	370	247	865	1200	516
700	1021361	-	1109	990	300	167	215	433	223	735	400	270	940	1275	422
800	1021254	-	1368	1059	325	185	230	449	248	750	420	277	975	1323	457
900	1021389	-	1559	1112	350	198	250	478	330	757	440	293	1025	1387	569
1000	1021370	-	1824	1169	380	212	270	508	261	760	460	308	1075	1405	490
1250	1021272	-	2588	1278	432	233	300	573	354	1006	530	323	1175	1660	620
1550	1021281	-	3650	1588	465	282	320	616	318	1075	580	338	1316	1896	693

\* 7t-300t Proof Load is 2 times the Working Load Limit. Ultimate Load is 5 times the Working Load Limit. 400t-1550t Proof Load is 1.33 times the Working Load Limit. Ultimate Load is 4.5 times the Working Load Limit. For Working Load Limit reduction due to side loading applications, see page 94.



# Crosby® Wide Body Shackles



**G-2160E**

- All sizes Quenched and Tempered for maximum strength.
- Forged alloy steel from 200 through 300 metric tons.
- Sizes 300 metric tons and smaller are proof tested to 2 times the Working Load Limit.
- All ratings are in metric tons, embossed on side of bow.
- G-2160, (75t and larger), bows are furnished Dimetcoated, and pins are Dimetcoated, then painted red.
- Shackles are **RFID EQUIPPED**.
- Greatly improves life of wire rope slings.
- Can be used to connect HIGH STRENGTH Synthetic Web Slings, HIGH STRENGTH Synthetic Round Slings or Wire Rope Slings.
- Increase in shackle bow radius provides minimum 58% gain in sling bearing surface and eliminates need for a thimble.
- Increases usable sling strength minimum of 15%.
- Approved for use at -40 degrees C (-40 degrees F) to 204 degrees C (400 degrees F).
- Bow and bolt are certified to meet charpy impact testing of 42 joules (31 ft-lbs.) min. avg. at -20 degrees C (-4 degrees F).
- All 2160E shackles are individually proof tested and magnetic particle inspected. Crosby certification available at time of order.
- Shackles requiring ABS, Lloyds and other certifications are available upon special request and must be specified at time of order.
- Shackles have DNV Type Approval to Rules for Certification of Lifting Appliances, and are produced in accordance with DNV MSA requirements. Databook is provided that includes required documents.
  - Serialization / Identification
  - Material Testing (Physical / Chemical / Charpy)
  - Proof Testing
- Look for the Red Pin® . . . the mark of genuine Crosby quality.

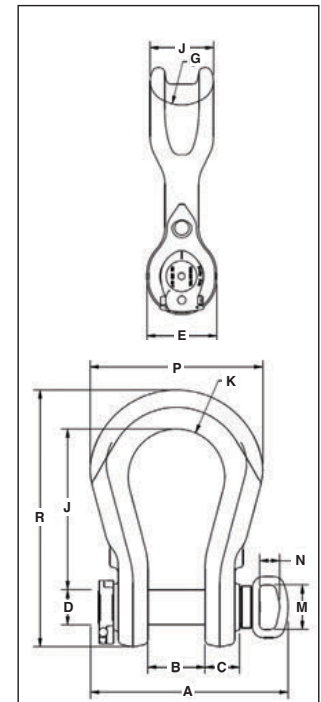

**SEE APPLICATION INFORMATION**  
 On Page 92 of the General Catalog  
 Para Español: [www.thecrosbygroup.com](http://www.thecrosbygroup.com)

## G-2160E Crosby® Easy-Loc “Wide Body” Shackles

Working Load Limit (t)*	Stock No.		Weight Each (kg)	Dimensions (mm)														Effective Body Diameter
	G-2160E	S-2160E		A	B +/- 6.35	C	D +/- .5	E	F	G	H	J	K	M	N	P	R	
75	1021500	—	242	425	130	88.9	80.0	165	30.2	95.3	365	150	110	101	45.7	393	584	173
125	1021509	—	418	425	130	88.9	80.0	165	30.2	95.3	365	150	110	101	45.7	393	584	173
200	1021518	—	900	501	150	86.1	104	213	44.5	133	460	219	137	101	45.7	519	773	241
300	1021527	—	1735	585	187	143	133	266	44.5	155	491	263	160	101	45.7	605	952	290

\* 125-300t Proof Load is 2 times the Working Load Limit. Ultimate Load is 5 times the Working Load Limit. For Working Load Limit reduction due to side loading applications, see page 94.



# Shackle Bolt Securement MADE EASY

The Patent Pending Easy-Loc V2™ shackle bolt securement system will change the way you make your next critical lift. It's shackle bolt securement made as easy as 1,2,3.

Wide opening ergonomic grip provides easy access for all hand sizes

Both shackle and pin are RFID equipped

316 stainless steel design resists corrosion

The new Easy-Loc V2™ can be retrofitted on all original Crosby Easy-Loc® Shackles

No cotter pin or tools required



**1** Open collar

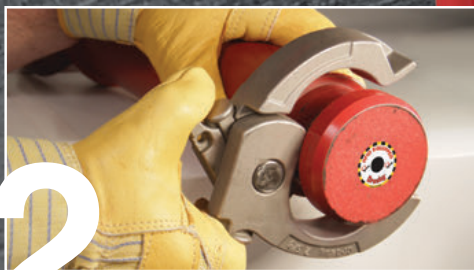

**2** Push collar onto bolt



**3** Close collar

- No cotter pins or tools required, reducing install/release time up to 90%
- Meets all industry standards
- Up to 60% lighter than conventional nut and cotter pin design

**Crosby**



Scan the QR code for more information on the new Easy-Loc V2™

Made in the U.S.A.

Contact your local authorized Crosby distributor or visit Crosby at [www.thecrosbygroup.com](http://www.thecrosbygroup.com)



# Crosby® Grommet Shackles



**G-2170**  
Grommet  
Shackle



Scan our QR Code with your smart device to visit the online flyer.

- All sizes Quenched and Tempered for maximum strength.
- All sizes cast alloy steel.
- All ratings are in metric tons, embossed on side of bow.
- G-2170 bows are furnished Dimetcoated and pins are Dimetcoated, then painted red.
- All sizes are **RFID EQUIPPED** in bow and pin.
- Designed for use with single or double large diameter grommets.
- Extra large sling contact area improves efficiency of the grommet sling.
- Shackles utilize new bolt system
- Large machined flat on ears that can be drilled and tapped for adapting other accessories.
- HR-1000 Hoist Ring in Bow available for easy transporting.
- Increases usable sling strength minimum of 60% and greatly improves life of grommet slings.
- Bow and bolt are certified to meet charpy impact testing of 42 joules (31 ft-lbs.) min. avg. at -20 degrees C (-4 degrees F).
- All 2170 shackles are individually proof tested and magnetic particle inspected.
- Shackles requiring ABS, Lloyds, and other certifications are available upon special request and must be specified at time of order.
- All 2170 shackles can meet requirements of DNV Rules for Certification of Lifting Appliances upon special request and must be specified at time of order.
  - Serialization / Identification
  - Material Testing (Physical / Chemical / Charpy)
  - Proof Testing
- Look for the Red Pin®....the mark of genuine Crosby quality.

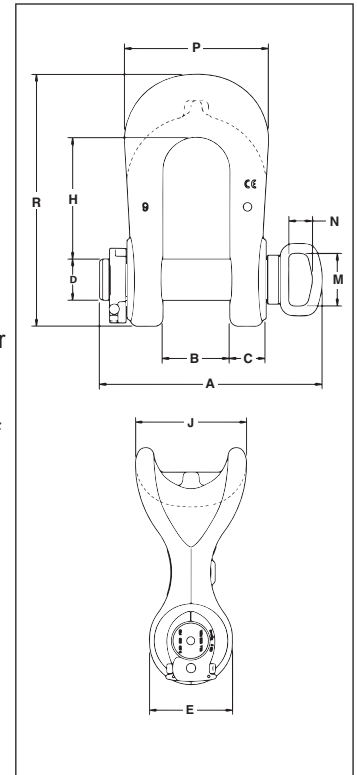

**SEE APPLICATION INFORMATION**  
On Page 92 of the General Catalog  
Para Español: [www.thecrosbygroup.com](http://www.thecrosbygroup.com)

## G-2170 Crosby® Grommet Shackles

Working Load Limit (t)*	Stock No.	Weight Each (kg.)	Dimensions (mm)												Effective Body Diameter
	G-2170		A	B +/- 6.35	C	D +/- .5	E	F	H	J	M	N	P	R	
75	1022075	51.26	358	105	60.7	69.9	140	30.2	197	191	45.7	102	241	411	286
125	1022084	79.83	408	130	69.9	80.0	171	30.2	236	229	45.7	102	279	489	343
200	1022093	166.9	486	150	86.1	105	229	44.4	296	328	45.7	102	346	635	469
300	1022100	311.1	570	187	109	133	283	44.4	386	394	45.7	102	432	808	578
500	1022119	756.6	772	250	152	180	349	44.4	501	508	45.7	102	584	1053	762

\* Sizes 75-300 metric tons are proof tested to 2 times the Working Load Limit. 500 metric ton proof tested to 1.33 times Working Load Limit. Ultimate Load is 5 times the Working Load Limit. For Working Load Limit reduction due to side loading applications, see pages 94.



**G-2130CT  
and  
G-2140CT**



- Forged - Quenched and Tempered, with alloy bolt.
  - G-2130CT - Carbon Steel
  - G-2140CT - Alloy Steel
- Working Load Limit permanently shown on every shackle.
- Individually serialized with certification.
- Fatigue Rated (G-2130CT only).
- Shackles 25t and larger are **RFID EQUIPPED**.
- All sizes are individually proof tested to 2.0 times the Working Load Limit.
- Finish is inorganic zinc primer.
- Bow and bolt are certified to meet charpy impact testing of 42 joules (31 ft-lbs.) min. avg. at -20 degrees C (-4 degrees F).
- Individually mag inspected with certification.
- Type Approval and certification in accordance with DNV 2.7-1 Offshore Containers, and Rules for Certification of Lifting Appliances, DNV OS-101 and are produced in accordance with DNV MSA requirements, including required documents.
- COLD TUFF® shackles are suitable for use to (-45° C).
- Refer to page 167 for COLD TUFF® Master Links and Master Link assemblies.

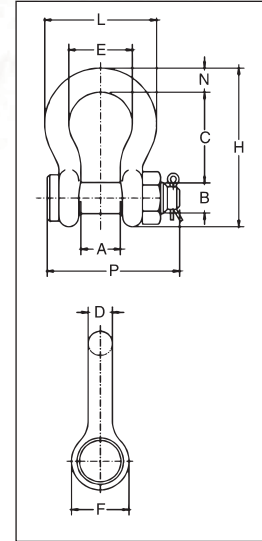

**SEE APPLICATION INFORMATION**  
On Page 92 of the General Catalog  
Para Español: [www.thecrosbygroup.com](http://www.thecrosbygroup.com)

**Crosby® G-2130CT COLD TUFF® Shackles**

Nominal Shackle Size (in.)	Working Load Limit (t)*	G-2130CT Stock No.	Weight Each (kg)	Dimensions (mm)										Tolerance +/-	
				A	B	C	D	E	F	H	L	N	P	A	C
3/4	4-3/4	1260568	1.23	31.8	22.4	71.5	19.1	51.0	46.0	126	89.0	20.6	108	1.50	6.35
7/8	6-1/2	1260577	1.76	36.6	25.4	84.0	22.4	58.0	53.0	148	102	24.6	120	1.50	6.35
1	8-1/2	1260586	2.57	42.9	28.7	95.5	26.2	68.5	60.5	167	119	26.9	137	1.50	6.35
1-1/8	9-1/2	1260595	3.75	46.0	31.8	108	28.7	74.0	68.5	190	131	31.8	150	1.50	6.35
1-1/4	12	1260604	5.31	51.5	35.1	119	32.8	82.5	76.0	210	146	35.1	168	1.50	6.35
1-3/8	13-1/2	1260613	6.85	57.0	38.1	133	35.1	92.0	84.0	233	162	38.1	183	3.30	6.35
1-1/2	17	1260622	9.43	60.5	41.4	146	39.1	98.5	92.0	254	175	41.1	195	3.30	6.35
1-3/4	25	1260633	15.4	73.0	51.0	178	46.7	127	106	313	225	57.0	233	3.30	6.35

Bolt Type Anchor shackle with thin head bolt - nut with cotter pin. Meets the performance requirements of Federal Specification RR-C-271F Type IVA, Grade A, Class 3, except for those provisions required of the contractor. For additional information, see page 468.

**\* NOTE: Maximum Proof Load is 2.0 times the Working Load Limit. 4-3/4t - 25t, Minimum Ultimate Load is 5.4 times the Working Load Limit. For Working Load Limit reduction due to side loading applications, see page 94.**

**Crosby® G-2140CT COLD TUFF® Shackles**

Nominal Shackle Size (in.)	Working Load Limit (t)*	G-2140CT Stock No.	Weight Each (kg)	Dimensions (mm)										Tolerance +/-	
				A	B	C	D	E	F	H	L	N	P	A	C
1-1/2	30	1260801	9.43	60.5	41.4	146	38.9	98.6	91.9	254	175	41.1	196	3.3	6.4
1-3/4	40	1260812	15.4	73.2	50.8	178	46.7	127	106	313	224	57.2	237	3.3	6.4
2	55	1260823	23.6	82.6	57.2	197	52.8	146	122	347	258	61.0	264	3.3	6.4
2-1/2	85	1260834	43.5	105	69.9	267	68.8	184	148	455	324	79.2	345	6.4	6.4
3	120	1260843	81	127	82.6	330	79.2	200	165	546	371	92.2	384	6.4	6.4
3-1/2	† 150	1260852	120	133	95.3	372	91.9	229	203	632	432	111	448	6.4	6.4
4	† 175	1260861	153	140	108	368	102	254	229	652	457	116	517	6.4	6.4
4-3/4	† 200	1260870	204	184	121	397	114	279	267	743	533	152	539	6.4	6.4
5	† 250	1260889	272	216	127	508	114	330	305	889	622	165	576	6.4	6.4

Bolt Type Anchor shackle with thin head bolt - nut with cotter pin. Meets the performance requirements of Federal Specification RR-C-271F Type IVA, Grade A, Class 3, except for those provisions required of the contractor. For additional information, see page 468.

**\* NOTE: Maximum Proof Load is 2.0 times the Working Load Limit. 30t - 175t, Minimum Ultimate Load is 5.4 times the Working Load Limit. 200t and larger, Minimum Ultimate Load is 4 times the Working Load Limit. † Furnished with Round Head Bolts with welded handle. For Working Load Limit reduction due to side loading applications, see page 94.**





**S-209T  
THEATRICAL  
SHACKLE**

- Sizes: 3/8" through 3/4"
- Capacities: 1 through 4-3/4 metric tonnes.
- Forged - Quenched and Tempered, with alloy pins.
- Working Load Limit permanently shown on every shackle.
- Flat black baked on power coat finish.
- Fatigue Rated.
- Industry leading 6 to 1 design factor.
- Screw pin anchor shackles meet the performance requirement of Federal Specification RR-C-271F Type A, Grade A, Class 2, except for those provisions required of the contractor.
- Meets the performance requirements of EN 13889:2003.
- Meets or exceeds all requirements of ASME B30.26 including identification, ductility, design factor, proof load and temperature requirements. Importantly, these shackles meet other critical performance requirements including fatigue life, impact properties and material traceability, not addressed by ASME B30.26.

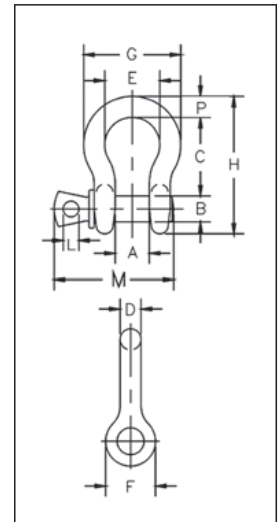

**SEE APPLICATION INFORMATION**  
On Page 92 of the General Catalog  
Para Español: [www.thecrosbygroup.com](http://www.thecrosbygroup.com)

## S-209T Theatrical Shackles

Nominal Size (in.)	Working Load Limit (t)*	S-209T Stock No.	Weight Each (kg)	Dimensions (mm)												Tolerance +/-	
				A	B	C	D	E	F	G	H	L	M	P	C	A	
3/8	1	1018706	.14	16.8	11.2	36.6	9.65	26.2	23.1	45.2	63.0	6.35	51.5	9.65	3.30	1.50	
7/16	1-1/2	1018724	.17	19.1	12.7	42.9	11.2	29.9	26.9	51.5	74.0	7.85	60.5	11.2	3.30	1.50	
1/2	2	1018742	.33	20.6	16.0	47.8	12.7	33.3	30.2	58.5	83.5	9.65	68.5	12.7	3.30	1.50	
5/8	3-1/4	1018760	.62	26.9	19.1	60.5	16.0	42.9	38.1	74.5	106	11.2	85.0	17.5	6.35	1.50	
3/4	4-3/4	1018778	1.07	31.8	22.4	71.5	19.1	51.0	46.0	89.0	126	12.7	101	20.6	6.35	1.50	

\* Minimum Ultimate Load is 5 times the Working Load Limit. Maximum Proof Load is 2.0 times the Working Load Limit.

### ***S-209T... The "Crosby"***

When you're looking for the top-named shackle used for theatrical and stage rigging applications, ask for a "Crosby"—the name synonymous with quality, safety and heavy lifting. The S-209T shackle is enhanced with a flat black baked-on power coat finish that causes the shackle to blend in with stage surroundings. This guarantees "behind-the-scene" strength and dependability without detracting the eye from on-stage action.



**SHACKLES**



**G-209R  
ROV SHACKLE**  
with "D" Style Handle  
Shown



Scan our QR Code with your smart device to visit the online flyer.

- Capacities from 8-1/2t through 55t.
- Forged Steel, Quenched & Tempered, with alloy pins.
- Handles are stainless steel.
- Shackles and bolts are available in both "D" and "F" designs.
- Working Load Limit permanently shown on every shackle.
- **QUIC-CHECK®** deformation and angle indicators forged on the bow.
- All ROV shackle bows are galvanized, then painted fluorescent yellow.
- Handles are painted fluorescent orange.
- New Interchangeable handles on ROV shackle bolts.
- "D" and "F" handle kits available containing handle, retaining bolts and individual packet of Loctite® for easy installation.
- Handles are **RFID EQUIPPED**.
- Look for the Red Pin®... the mark of genuine Crosby quality.

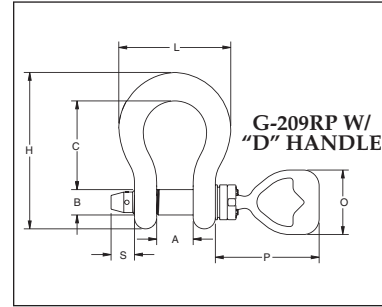
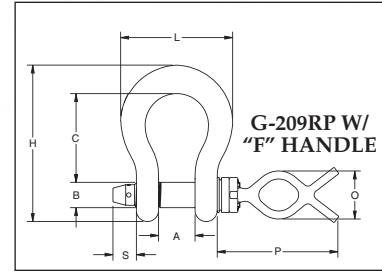

**NOTE: ROV Hooks available on page 130 and 131.**



**SEE APPLICATION INFORMATION**

On Page 92 of the General Catalog  
Para Español: [www.thecrosbygroup.com](http://www.thecrosbygroup.com)

**G-209RP ROV Shackles with "D" or "F" Style Handle**

Working Load Limit (t)*	G-209RP with "F" Style Handle Dimensions (mm)										G-209RP with "D" Style Handle Dimensions (mm)									
	Weight Each (kg)	A +/-	B	C +/-	H	L	O	P	S	T	Weight Each (kg)	A +/-	B	C +/-	H	L	O	P	S	T
8-1/2	3.5	42.9	28.7	95.3	167	119	96.3	220	31.2	16.0	3.8	42.9	28.7	95.3	167	119	129	184.2	31.2	16.0
9-1/2	4.5	46.0	31.8	108	190	131	96.3	220	31.2	16.0	4.7	46.0	31.8	108	190	131	129	184.2	31.2	16.0
12	5.6	51.6	35.1	119	210	146	96.3	220	33.0	16.0	5.9	51.6	35.1	119	210	146	129	184.2	33.0	16.0
13-1/2	7.1	57.2	38.1	133	233	162	96.3	220	35.6	16.0	7.4	57.2	38.1	133	233	162	129	184.2	35.6	16.0
17	8.4	60.5	41.4	146	254	175	96.3	244	45.5	16.0	8.7	60.5	41.4	146	254	175	129	208.0	45.5	16.0
25	15.5	73.2	50.8	178	313	224	96.3	244	47.0	16.0	15.7	73.2	50.8	178	313	224	129	208.0	47.0	16.0
35	22.0	82.6	57.2	197	348	258	96.3	248	49.2	16.0	22.3	82.6	57.2	197	348	258	129	212.6	49.2	16.0
55	43.2	105	69.9	267	455	324	96.3	258	52.3	16.0	43.5	105	69.9	267	455	324	129	212.3	52.3	16.0

\* Minimum Ultimate Load is 5 times the Working Load Limit. \* NOTE: Maximum Proof Load is 2.0 times the Working Load Limit.



**G-209RP Bows with Pin. G-4209 Handles and Pin Assemblies**

Working Load Limit (t)*	G-209RP Bow with Pin (less Handle)		G-4209R Handle Only				G-4209RFB "F" Pin Assembly		G-4209RDB "D" Pin Assembly	
	Stock No.	Weight Each (kg)	"F" Handle Stock No.	Weight Each (kg)	"D" Handle Stock No.	Weight Each (kg)	Stock No.	Weight Each (kg)	Stock No.	Weight Each (kg)
8-1/2	1021200	0.5	1021085	1.3	1021094	1.6	1020638	1.8	1020816	2.1
9-1/2	1021208	0.8					1020647	2.0	1020825	2.4
12	1021217	1.0					1020656	2.3	1020834	2.6
13-1/2	1021226	1.3					1020665	2.6	1020843	2.9
17	1021235	2.3					1020674	3.6	1020852	3.9
25	1021244	3.6					1020683	4.9	1020861	8.5
35	1021253	5.1					1020692	6.4	1020870	11.4
55	1021262	9.6					1020709	10.9	1020889	20.5

\* Minimum Ultimate Load is 5 times the Working Load Limit. \* NOTE: Maximum Proof Load is 2.0 times the Working Load Limit.



**HOW TO ORDER:** Crosby ROV shackles are designed in a way to allow multiple handle styles to be used with each size of shackles bow. To ensure the proper components are selected, please use the following steps.

- STEP 1 - Determine the Working Load Limit (WLL) of the desired shackle.
- STEP 2 - Select the G-209RP bow with pin (less handle) that corresponds to the desired WLL.
- STEP 3 - Select the G-4209R handle that best meets your requirements.
- STEP 4 - When placing the order through your local authorized Crosby dealer, reference the corresponding stock numbers associated with the items selected in Steps 2 and 3 above.



# Crosby® ROV Shackles



**G-209R  
ROV SHACKLE**

- Capacities from 6-1/2t through 55t.
- Forged Steel, Quenched & Tempered, with alloy pins.
- Working Load Limit permanently shown on every shackle.
- Fatigue rated.
- **QUIC-CHECK®** deformation and angle indicators forged on the bow.
- All ROV shackle bows are galvanized, then painted fluorescent yellow.
- Look for the Red Pin® . . . the mark of genuine Crosby quality.

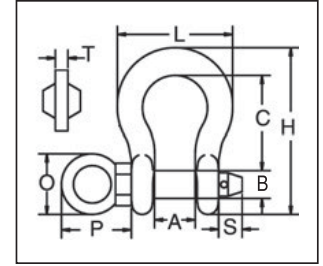

**NOTE: ROV Hooks available on page 130 and 131.**



**SEE APPLICATION INFORMATION**  
On Page 92 of the General Catalog  
Para Español: [www.thecrosbygroup.com](http://www.thecrosbygroup.com)

## G-209R Subsea Shackles

Working Load Limit (t)*	G-209R Stock No.	Weight Each (kg)	Dimensions (mm)								
			A +/- 6.35	B	C	H	L	O	P	S	T
6-1/2	1020872	1.69	36.6	25.4	84.0	148	102	50	58	17	10
8-1/2	1020902	2.59	42.9	28.7	95.5	167	119	50	61	18	10
9-1/2	1020932	3.77	46.0	31.8	108	190	131	70	83	18	12
12	1020952	5.02	51.5	35.1	119	210	146	70	84	23	12
13-1/2	1020972	6.65	57.0	38.1	133	233	162	75	91	23	15
17	1020992	8.58	60.5	41.4	146	254	175	75	93	24	15
25	1021102	14.1	73.0	51.0	178	313	225	90	114	29	17.5
35	1021125	21.4	82.5	57.0	197	348	253	106	132	30	20
55	1021158	42.8	105	70.0	267	453	327	120	145	45	25

\* Minimum Ultimate Load is 5 times the Working Load Limit.

## ROV Shackles & Hooks

In conjunction with major North Sea operations, Crosby has developed specifically-designed products to be used in underwater and/or subsea exercises. These products are designed to be highly visible and easy to use for the ROV operator. The Crosby ROV product line reflects the company's unmatched quality and safety standards while providing versatility for a variety of subsea applications. ROV hooks can be found on pages 130 and 131 of this catalog.

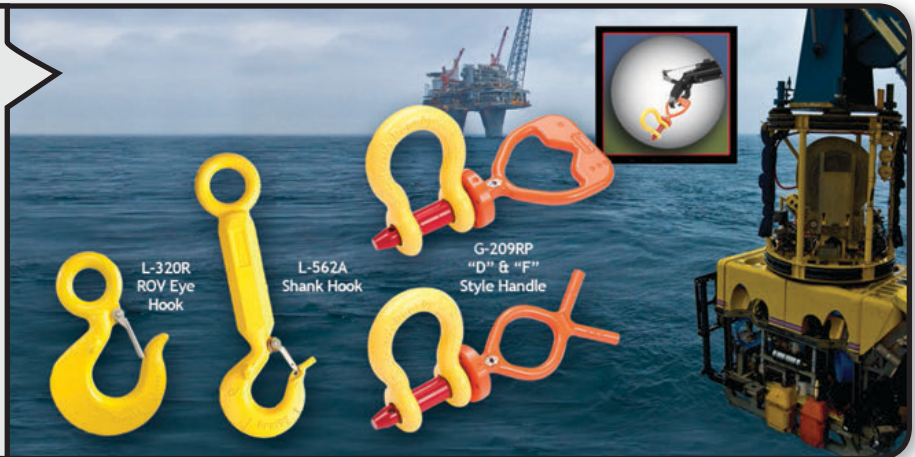

**SHACKLES**

### Round Pin Shackles



**Round Pin Shackles** can be used in tie down, towing, suspension or lifting applications where the load is strictly applied in-line. Round pin shackles should never be used in rigging applications to gather multiple sling legs, or where side loading conditions may occur.

### Screw Pin Shackles



**Screw Pin Shackles** are used in Pick and Place\* applications. For permanent or long-term installations, Crosby recommends the use of bolt type shackles.

If you choose to disregard Crosby's recommendation, the screw pin shall be secured from rotation or loosening (Page 93).

Screw pin shackles can be used for applications involving side-loading circumstances. Reduced working load limits are required for side-loading applications. While in service, do not allow the screw pin to be rotated by a live line, such as a choker application.

\* Pick and Place application: Pick (move) a load and place as required. Tighten screw pin before each pick.

### Bolt-Type Shackles



**Bolt-Type Shackles** can be used in any application where round pin or screw pin shackles are used. In addition, they are recommended for permanent or long term installations and where the load may slide on the shackle pin causing the pin to rotate. The bolt-type shackle's secondary securement system, utilizing a nut and cotter, eliminates the requirement to tighten pin before each lift or movement of load.

## QUIC-CHECK®



All Crosby Shackles, with the exception of 2160, 2169, 2170, 252 and 253 styles incorporate markings forged into the product that address an easy to use **QUIC-CHECK®** feature. Angle indicators are forged into the shackle bow at 45 degree\*\* angles from vertical. These are utilized on screw pin and bolt type shackles to quickly check the approximate angle of a two-legged hitch, or quickly

check the angle of a single leg hitch when the shackle pin is secured and the pull of the load is off vertical (side loaded), thus requiring a reduction in the working load limit of the shackle.

\*\* **Round Pin Shackles** utilize the 45 degree **QUIC-CHECK®** indicators to ensure load is applied strictly in-line.

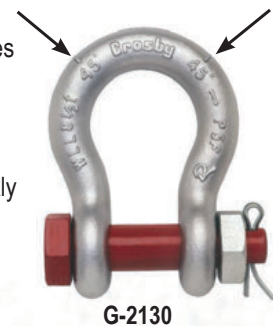





**RIGGING PRACTICE SHACKLES**

Screw pin shall be fully engaged. If designed for a cotter pin, it shall be used and maintained. Applied load should be centered in the bow to prevent side loading. Multiple sling legs should not be applied to the pin. If side loaded, the rated load shall be reduced according to Table 1 on pages 94.

**Screw Pin Shackles Pin Security**

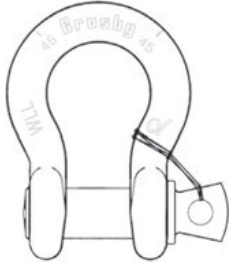

**MOUSE SCREW PIN WHEN USED IN LONG-TERM OR HIGH-VIBRATION APPLICATIONS.**

Mouse or Mousing (screw pin shackle) is a secondary securement method used to secure screw pin from rotation or loosening. Annealed iron wire is looped through hole in collar of pin and around adjacent leg of shackle body with wire ends securely twisted together.

**Shackles**

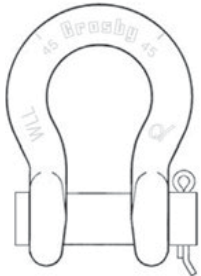

**ROUND PIN**

Do not side load, do not use as a collector ring, always use cotter pin.

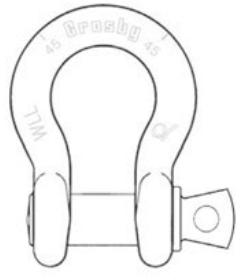

**SCREW PIN**

Use when picking and placing a load, tighten pin prior to each lift.

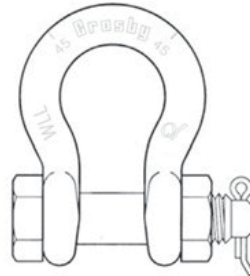

**BOLT-TYPE**

Use in permanent or long-term installations, always use nut and cotter.

**Connection of Slings to Shackles**



Diameter of shackle must be greater than wire rope diameter if no thimble in eye.



Shackle must be large enough to avoid pinching of synthetic slings.

**Bolt-Type Shackles**

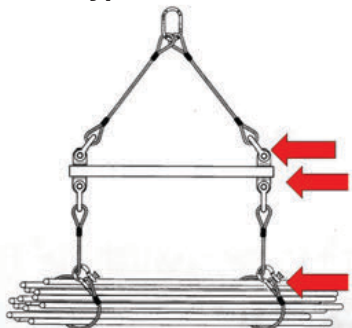

Use Bolt-Type Shackle when a permanent or long-term connection.

Use a screw pin shackle when it will be a temporary connection.

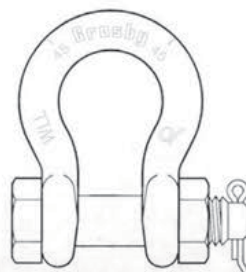

**WIRE ROPE SLINGS AND CONNECTIONS TO FITTINGS**

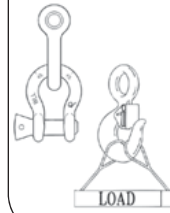

USE A THIMBLE TO PROTECT SLING AND TO INCREASE D/d

NEVER PLACE EYE OVER A FITTING SMALLER DIAMETER OR WIDTH THAN THE ROPE'S DIAMETER

**WIRE ROPE SLINGS AND CONNECTIONS TO FITTINGS**

NEVER PLACE A SLING EYE OVER A FITTING WITH A DIAMETER OR WIDTH GREATER THAN ONE HALF THE NATURAL LENGTH OF THE EYE

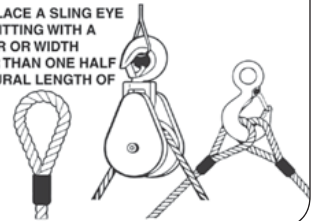

**SYNTHETIC SLINGS RATED LOAD**

FOLDING, BUNCHING OR PINCHING OF SYNTHETIC SLINGS, WHICH OCCURS WHEN USED WITH SHACKLES, HOOKS OR OTHER APPLICATIONS, WILL REDUCE THE RATED LOAD



BUNCHING



PINCHING

ASME B30.9

**CHOKER HITCH FORMED**

WITH SHACKLES

WITH CHOKER HOOK

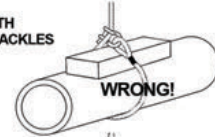

WRONG!

PLACE PIN IN EYE OF SLING

CORRECT!



**CROSBY SHACKLES POINT LOADING**

POINT LOADING OF CROSBY SHACKLE BOWS IS ACCEPTABLE

POINT LOADING OF CROSBY SHACKLE PINS IS ACCEPTABLE AS LONG AS LOAD IS REASONABLY CENTERED ON THE PIN

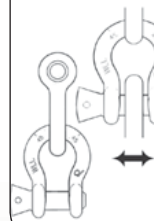

ALTHOUGH POINT LOADING IS ACCEPTABLE, A PAD EYE WIDTH OF 80% OR MORE OF SHACKLE SPREAD IS BEST PRACTICE

## SIDE LOADED RATING REDUCTION TABLE FOR 3/16" - 3" (120 METRIC TONS)

Angle loads must be applied in the plane of the bow.

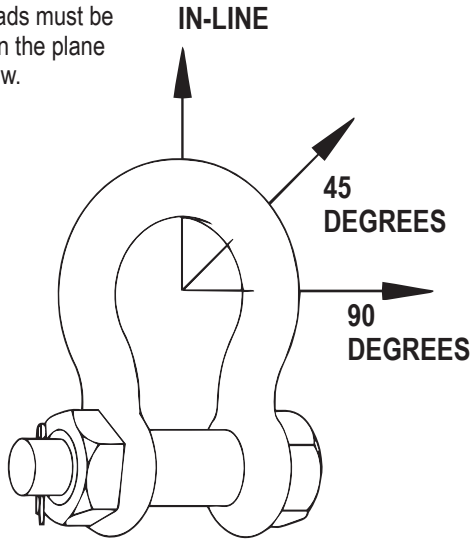

Side Loaded Rating Reduction Table for 3/16" - 3" (120 Metric Tons)

Table 1	
Side Loading Reduction Chart for Screw Pin and Bolt Type Shackles Only+	
Angle of Side Load from Vertical In-Line of Shackle	Adjusted Working Load Limit
0° - 5° In-Line*	100% of Rated Working Load Limit
45° from In-Line*	70% of Rated Working Load Limit
90° from In-Line*	50% of Rated Working Load Limit

+ In-Line load is applied perpendicular to pin. \* DO NOT SIDE LOAD ROUND PIN SHACKLE.

For shackles larger than 125 metric tons, where the angle of the side load is greater than 5 degrees, contact Crosby Engineering.

## INCLUDED ANGLE - SHACKLES

Never exceed 120° included angle. Use Bolt Type and Screw Pin Shackles ONLY.

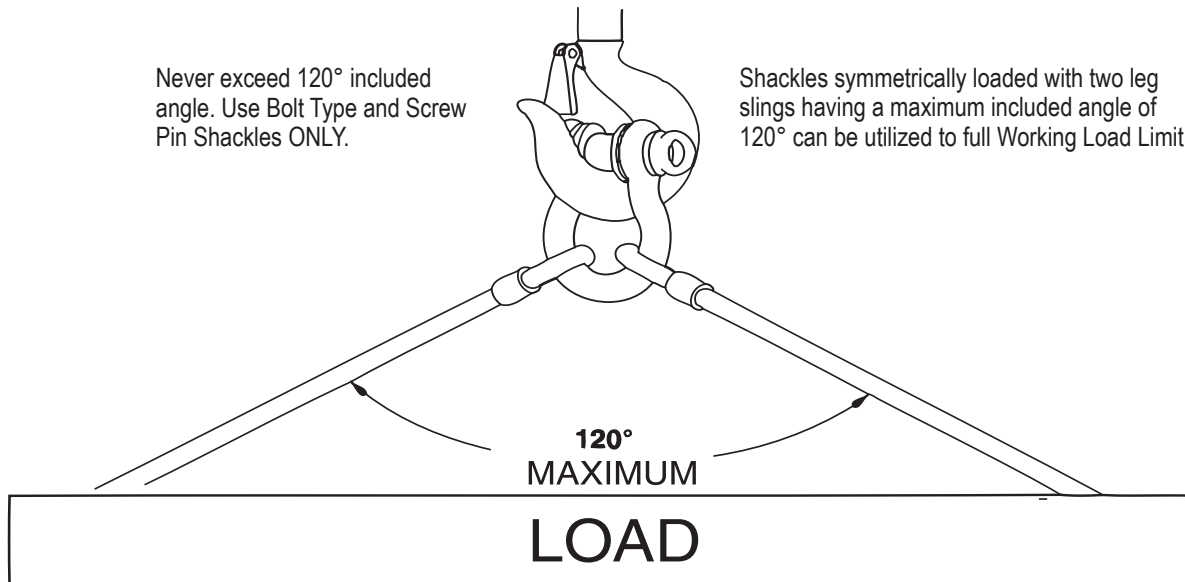

Shackles symmetrically loaded with two leg slings having a maximum included angle of 120° can be utilized to full Working Load Limit.

For shackles larger than 125 metric tons, the maximum included angle is 90 degrees for full working load limit. Contact Crosby Engineering if included angle is greater than 90 degrees.





# SLING SAVER FITTINGS

With Product Warnings and Application Information



# Lifting the World into the Future!



Cover protects sling as well as keeps it positioned correctly.

Pin threads into shackle and is secured with locknut. No retaining pin to snag the sling material.

Crosby, a world leader in lifting accessories, has developed the first full line of fittings designed for use with synthetic slings. For a "Systems" approach to rigging hardware for synthetics, Crosby's Sling Saver line is the choice.

Spool reduces sling wear.

Design allows for easy connection to other fittings.



Crosby's new Sling Saver line is designed to eliminate "bunching". The result: The full efficiency of the synthetic sling (Round or Webbing) can be achieved. Conventional hardware can reduce the efficiency of the sling significantly. Available in sizes 1.5" to 3" (35mm - 75mm). Capacity: 3-1/4 Tons to 8-1/2 Tons (2.95t-7.70t) Working Load Limit.

## Sling Saver<sup>®</sup>

Lifting the World into the Future

## Crosby<sup>®</sup>













For additional information, contact your local authorized Crosby Dealer or visit our web site at [www.thecrosbygroup.com](http://www.thecrosbygroup.com).





**WITH CROSBY'S NEW SLING SAVER® LINE OF HARDWARE, YOU WILL GET THE FULL RATED STRENGTH OF THE SLING AND EXTEND ITS LIFE.**

## RECOMMENDED APPLICATION CHART

APPLICATION	USE	COMMENTS
Web Slings, connect to Pad Eye, Eye Bolt, or Lifting Lug.	S-281 Sling Saver Web Sling Shackles – page 99 	<p>Always Ensure Rated Working Load Limits are Greater than the Load Placed on the Fitting. Designed for use with Type III (Eye &amp; Eye), Class 7, 2 ply webbing &amp; Synthetic Round Slings. Also accommodates single ply and endless slings.</p>
Web Slings or Roundslings, connecting to Pad Eye, Eye Bolt, or Lifting Lug.	S-253 or S-252 Sling Saver Shackles – page 100 	
Connect two S-252 or S-253 Sling Saver shackles together.	S-256 Link Plate – page 101 	
To keep the load centered on the Pin, thus keeping the sling positioned correctly in the shackle bow.	S-255 Spool – page 101 	
Web Slings or Roundslings connecting to Master Links, Rings, or Crosby 320N Eye Hooks.	S-280 Sling Saver Web Connector with spool – page 98 	
Web Slings or Roundslings connecting to Grade 8 Chain.	S-282 Sling Saver Chain Connector with spool – page 103 	
High Strength, High Capacity Web or Roundslings.	WS-320A Synthetic Sling Hook – page 102 	
Choking with Web Slings or Roundslings.	S-287 Sliding Choker Hook – page 103 	
Master Links or Master Link Assembly to be sewn into eye of Web Sling or attached utilizing web connector.	Welded Master Link A-344 and Master Link Assembly A-347 – pages 245 - 246 	
Web Sling being used to lift die blocks, or other equipment where standard Hoist Rings are used.	HR-125W – page 185 	
Connecting High Performance slings to master links or eye hooks and to other High Performance slings.	S-237 or S-238 High Performance Connectors – page 104 	
Wide Body Shackles greatly improve wearability of wire rope slings.	S/G-2160 "Wide Body" bolt type Shackles – pages 84 - 85 S/G-2169 "Wide Body" Screw Pin Shackles – page 78 	

Crosby Sling Saver hardware meets the requirements for minimum stock diameter or thickness and effective contact width shown in the recommended standard specification for synthetic Polyester Round Slings by the Web Sling and Tie Down Association. WSTDA-RS1 (revised 2010).

# Sling Saver® Web Connector



**S-280**



- All Alloy construction.
- Durable vinyl cover that:
  - Protects sling at eye
  - Keeps sling positioned correctly on spool.
- Design Factor of 5 to 1.
- Connects Synthetic Web and Synthetic Round Slings to conventional Crosby hardware including:
  - 320N Eye Hook
  - Additional Crosby Grade 8 Fittings
  - Master Links
  - Rings
  - Shackles
- Makes a field assembled bridle quick and easy.
- No retaining pin to snag sling material.
- Increased radius of spool gives wider sling bearing surface resulting in an increased area for load distribution, thus:
  - Increasing Synthetic Sling efficiency as compared to standard anchor and chain shackle bows and conventional eye hooks. This allows 100% of the slings rated Working Load Limit to be achieved.
  - Allowing better load distribution on internal fibers.
- Replacement kit for spool and web cover available.
- Designed for use with Type III (Eye & Eye), Class 7, 2 ply webbing & Synthetic Round Slings. Also accommodates single ply and endless slings.

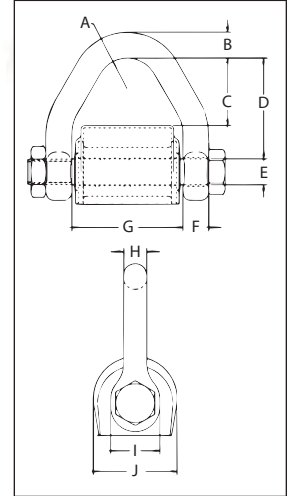

CE Sling Saver® Load Rated "QT" QUALITY TESTED



Crosby Sling Saver hardware meets the requirements for minimum stock diameter or thickness, and effective contact width shown in the Recommended Standards Specification for Synthetic Polyester Round Slings by the Web Sling & Tie Down Association. WSTDA-RS1 (revised 2010)

## S-280 Web Connector

Round Sling Size (No.)	Web Slings*			Working Load Limit (t)†	S-280 Stock No.	Weight Each (kg)	Dimensions (mm)									
	Webbing Width (mm)	Eye Width (mm)	Ply				A	B	C	D	E	F	G	H	I	J
1 & 2	50	50	2	2.95	1021681	.68	19.1	15.7	41.4	62.0	16.0	15.7	68.5	14.2	30.2	51.5
3	75	35	2	4.08	1021690	.86	19.1	17.5	27.9	51.0	19.1	17.5	55.5	15.2	35.1	59.5
4	100	50	2	5.67	1021700	1.32	19.1	20.6	42.2	65.0	22.4	19.1	68.5	17.5	41.1	62.5
5 & 6	150	75	2	7.70	1021709	2.31	25.4	23.9	62.5	89.0	25.4	22.4	93.5	22.4	47.8	72.0

\* Designed for use with Type III, (Eye & Eye), Class 7, 2 Ply web slings. For 3" and larger webbing width, tapered eye is required. † Maximum Proof Load is 2 times the Working Load Limit. Minimum Ultimate strength is 5 times the Working Load Limit.



# Sling Saver® Web Sling Shackles



## S-281

Web Sling Shackle is designed to connect Synthetic Web Slings and Synthetic Round Slings to eyebolts, pad eyes, and lifting lugs.

- All Alloy Construction.
- Design Factor of 5 to 1.
- Each shackle has a Product Identification Code (PIC) for material traceability along with a Working Load Limit and the name Crosby forged into it.
- Incorporates same ear spread and pin dimensions as conventional Crosby Shackles. Allows easy connection to pad eyes, eye bolts, and lifting lugs.
- Increased radius of bow gives wider sling bearing surface resulting in an increased area for load distribution, thus:
  - Increasing Synthetic Sling efficiency as compared to standard anchor and chain shackle bows and conventional eye hooks. This allows 100% of the sling's rated Working Load Limit to be achieved.
  - Allows better load distribution on internal fibers.
- Meets or exceeds all requirements of ASME B30.26 including identification, ductility, design factor, proof load and temperature requirements. Importantly, these shackles meet other critical performance requirements including fatigue life, impact properties and material traceability, not addressed by ASME B30.26.
- Look for the Red Pin® ... The mark of genuine Crosby Quality.

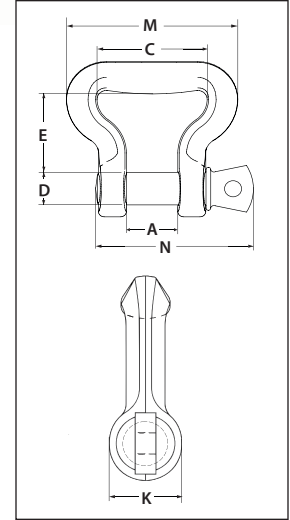

Crosby Sling Saver hardware meets the requirements for minimum stock diameter or thickness, and effective contact width shown in the Recommended Standards Specification for Synthetic Polyester Round Slings by the Web Sling & Tie Down Association. WSTDA-RS1 (revised 2010)

## S-281 Web Sling Shackle

Round Sling Size (No.)	Web Slings*			Working Load Limit (t)†	S-281 Stock No.	Weight Each (kg)	Dimensions (mm)						
	Webbing Width (mm)	Eye Width (mm)	Ply				A	C	D	E	K	M	N
1 & 2	50	50	2	2.95	1021048	.54	26.9	63.5	19.1	41.1	31.0	97.5	85.0
3	75	35	2	4.08	1021057	.68	31.8	51.0	22.4	38.1	35.8	86.0	101
4	100	50	2	5.67	1021066	1.13	36.6	63.5	25.4	51.0	41.1	107	114
5 & 6	150	75	2	7.70	1021075	1.95	42.9	92.0	28.7	70.0	46.7	143	130

\* Designed for use with Type III, (Eye & Eye), Class 7, 2 Ply web slings. For 3" and larger webbing width, tapered eye is required. † Maximum Proof Load is 2 -1/2 times the Working Load Limit. Minimum Ultimate strength is 5 times the Working Load Limit.

### Web Slings vs. Roundslings

**Web Slings** are flexible, lightweight, and have a flat construction, normally with eyes at both ends. The flexibility of the sling helps to reduce shock loading effects. It is also important to note that the load-bearing yarns of the sling come in direct contact with the load. **Roundslings**, however, are a continuous loop of yarn covered by a woven tubular casing. This casing comes in direct contact with the load, which helps to protect the load-bearing yarns inside. **Whether Web or Round, rest assured that the Crosby Sling Saver® product line offers the fittings you need to get the most out of your slings in the toughest lifting applications and environments.**



SLING SAVER FITTINGS

# Sling Saver® Web Sling Shackles



**S-252  
BOLT TYPE  
SLING SHACKLE**

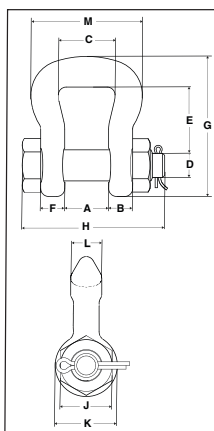

- Shackles available in size 3-1/4 to 50 metric tons.
- All Alloy construction.
- Design factor of 5 to 1.
- Each shackle has a Product Identification Code (PIC) for material traceability along with a Working Load Limit and the name Crosby forged into it.
- Increased radius of bow gives wider sling bearing surface resulting in an increased area for load distribution, thus:
  - Increasing Synthetic Sling efficiency as compared to standard anchor and chain shackle bows and conventional hooks. This allows 100% of the sling's rated Working Load Limit to be achieved.
  - Allows better load distribution on internal fibers.
- Meets or exceeds all requirements of ASME B30.26 including identification, ductility, design factor, proof load and temperature requirements. Importantly, these shackles meet other critical performance requirements including fatigue life, impact properties and material traceability, not addressed by ASME B30.26.
- Shackles available in both a Screw Pin and Bolt, Nut and Cotter Pin configuration.
- Bolt (Pin) has a larger diameter that provides better load distribution.
- Look for the Red Pin®... the mark of Genuine Crosby quality.



**S-253  
SCREW PIN  
SLING SHACKLE**

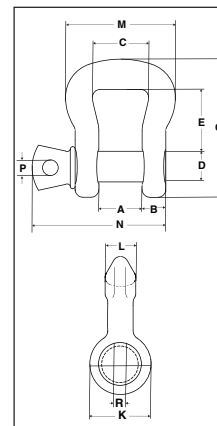

Crosby Sling Saver hardware meets the requirements for minimum stock diameter or thickness, and effective contact width shown in the Recommended Standards Specification for Synthetic Polyester Round Slings by the Web Sling & Tie Down Association. WSTDA-RS1 (revised 2010)

## S-252 Bolt Type Sling Shackle

Web Sling Eye Width (mm)	Round Sling Size (No.)	Working Load Limit (t)*	S-252 Stock No.	Weight Each (kg)	Dimensions (mm)												
					A	B	C	D	E	F	G	H	J	K	L	M	
25	1 & 2	3-1/4	1020485	.64	26.9	14.7	35.1	19.1	38.1	11.2	86.0	93.5	28.4	38.1	19.1	68.5	
35	3 & 4	6-1/2	1020496	1.09	31.8	19.1	44.5	22.4	47.8	12.7	105	108	33.3	46.0	25.4	86.0	
50	5 & 6	8-3/4	1020507	1.86	35.1	22.4	57.0	25.4	71.5	14.2	140	120	38.1	53.0	28.4	106	
75	7 & 8	12-1/2	1020518	3.63	41.1	28.4	82.5	31.8	77.5	19.1	161	149	47.8	66.5	35.1	143	
100	9 & 10	20-1/2	1020529	7.67	54.0	35.1	114	38.1	133	22.4	240	183	57.0	79.0	44.5	191	
125	11 & 12	35	1020540	15.9	63.5	44.5	140	51.0	161	28.4	292	236	76.0	106	57.0	233	
150	13	50	1020551	26.1	76.0	54.0	165	57.0	196	31.8	349	264	86.0	121	70.0	279	

\* Maximum Proof Load is 2.5 times the Working Load Limit. Minimum Ultimate strength is 5 times the Working Load Limit.

## S-253 Screw Pin Sling Shackle

Web Sling Eye Width (mm)	Round Sling Size (No.)	Working Load Limit (t)*	S-253 Stock No.	Weight Each (kg)	Dimensions (mm)												
					A	B	C	D	E	G	K	L	M	N	P	R	
25	1 & 2	3-1/4	1020575	.64	22.4	15.7	35.1	19.1	38.1	86.0	38.1	19.1	68.5	82.0	11.2	25.4	
35	3 & 4	6-1/2	1020584	1.00	31.8	19.1	44.5	22.4	47.8	105	46.0	25.4	86.0	102	12.7	30.2	
50	5 & 6	8-3/4	1020593	1.72	35.1	22.4	57.0	25.4	71.5	140	53.0	28.4	106	114	12.7	36.6	
75	7 & 8	12-1/2	1020602	3.31	41.1	28.4	82.5	31.8	77.5	161	66.5	35.1	143	142	15.7	46.0	
100	9 & 10	20-1/2	1020611	6.89	54.0	35.1	114	38.1	133	240	79.0	44.5	191	175	19.1	54.0	
125	11 & 12	35	1020620	14.0	63.5	44.5	140	51.0	161	292	106	57.0	233	220	25.4	73.0	
150	13	50	1020629	23.6	76.0	54.0	165	57.0	196	349	121	70.0	279	260	31.0	81.0	

\* Maximum Proof Load is 2.5 times the Working Load Limit. Minimum Ultimate strength is 5 times the Working Load Limit.





S-255  
SPOOL



## S-255 Spool

- The "Spool" is designed to keep the load centered on the pin, thus keeping the sling positioned correctly in the shackle bow.

Working Load Limit (t)*	S-255 Stock No.	Weight Each (kg)	Dimensions (mm)			
			A	B	C	D
3-1/4	1020903	0.15	31.8	20.6	19.1	4.85
6-1/2	1020912	0.26	38.1	23.9	25.4	6.35
8-3/4	1020921	0.40	44.5	26.7	30.2	7.85
12-1/2	1020930	0.66	51.0	33.3	38.1	9.65
20-1/2	1020939	1.27	63.5	41.4	47.8	11.2
35	1020948	1.09	82.5	54.0	57.0	12.7
50	1020957	1.84	95.5	60.5	70.0	15.7

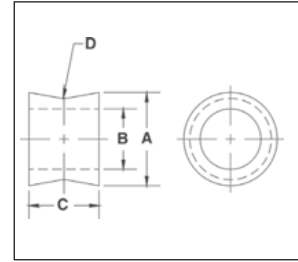

\* Maximum Proof Load is 2.5 times the Working Load Limit. Minimum Ultimate strength is 5 times the Working Load Limit.



S-256  
LINK PLATE



## S-256 Link Plate

- The "Link Plate" is designed to connect two (2) S-252 or S-253 "Sling Saver" Shackles together.

Working Load Limit (t)*	S-256 Stock No.	Weight Each (kg)	Dimensions (mm)				
			A	B	C	D	E
3-1/4	1020785	.38	19.1	38.1	86.0	20.6	47.8
6-1/2	1020796	.73	25.4	44.5	105	23.9	57.0
8-3/4	1020807	1.23	31.8	51.0	121	26.9	66.5
12-1/2	1020818	2.35	38.1	63.5	152	33.3	85.6
20-1/2	1020829	3.71	44.5	76.0	178	41.1	95.5
35	1020840	7.80	51.0	102	235	54.0	127
50	1020851	17.0	73.1	127	267	60.5	146

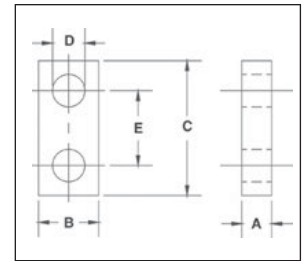

\* Maximum Proof Load is 2.5 times the Working Load Limit. Minimum Ultimate strength is 5 times the Working Load Limit.

**Sling Saver®**



See page 105 for more information on the above products and how these products are integrated into synthetic sling systems.

## The Rigging Triangle

An important aspect of rigging safety is knowing how to form a proper rigging triangle. The rigging triangle is formed any time two or more slings are connected to a load and load hook. It is important to remember that as the rigging triangle becomes flatter, the horizontal sling angles become smaller, which increases sling tension. To avoid this, **a horizontal sling angle of 60 degrees or greater is considered optimal for all hitches.** At a 60 degree angle, the sling tension multiplier is only 1.15, the side or angular loading is limited, and the crushing load is 50 percent of the sling tension, which is considered minimal. **A helpful tip to verify that the slings are rigged at 60 degrees is to remember that a 60-degree sling angle is formed when an equilateral triangle is created.** This means that the sling length will be equal to the distance between pick points.



# Sling Saver® Synthetic Sling Hooks



**WS-320A  
SYNTHETIC  
SLING HOOK**

- Hook capacities available: 1-1/2, 3, and 5 metric tons.
- All Alloy construction.
- Design factor of 5 to 1.
- Each hook has a Product Identification Code (PIC) for material traceability along with a working load limit and the name Crosby forged into it.
- Originally designed for 2-Ply Web slings, the Crosby Web Sling hook can also be used with Round Slings as long as the Working Load Limit ratings are compatible. The new hook incorporates the following features:
  - Eye is designed with a wide beam surface which:
  - Eliminates bunching effects.
  - Reduces sling tendency to slide.
  - Allows a better load distribution on internal fibers.
- All hooks feature Crosby's patented **QUIC-CHECK®** indicators.
- Hook Web Sling Eye width available: 25, 50 and 75mm.
- Fatigue rated to 20,000 cycles at 1-1/2 times the Working Load Limit.

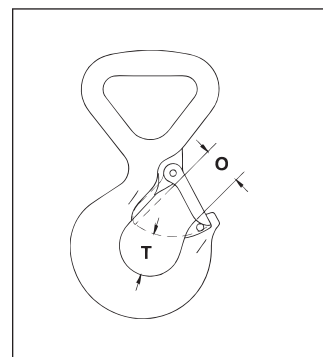
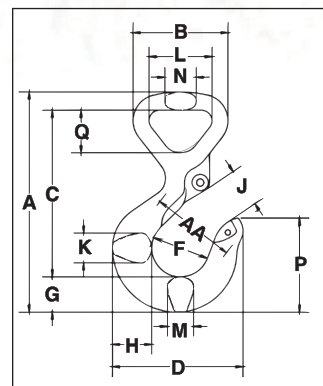

**Fatigue Rated Load Rated Sling Saver**



Crosby Sling Saver hardware meets the requirements for minimum stock diameter or thickness, and effective contact width shown in the Recommended Standards Specification for Synthetic Polyester Round Slings by the Web Sling & Tie Down Association. WSTDA-RS1 (revised 2010)

## WS-320A Synthetic Sling Hook

Web Sling Eye Width (mm)	Round Sling Size (No.)	Working Load Limit (t)*	WS-320A Stock No.	WSL-320A with Latch	Weight Each (kg)	Hook I.D. Code	S-4320 Rep. Latch
25.0	1	1-1/2	1022701	1022706	.50	FA	1096374
50.0	2	3	1022712	1022717	1.30	HA	1096468
75.0	3	5	1022723	1022728	2.99	IA	1096515

## WS-320A Synthetic Sling Hook

Hook ID Code	Working Load Limit (t)*	Dimensions (mm)																
		A	B	C	D	F	G	H	J	K	L	M	N	O	P	Q	T	AA
FA	1-1/2	133	57.5	101	79.0	35.1	21.3	23.9	23.6	18.0	38.1	16.0	19.1	23.1	57.0	25.7	24.9	51.0
HA	3	181	93.0	135	101	41.4	28.7	33.5	28.7	23.9	63.5	21.6	28.7	27.7	71.5	42.9	29.5	51.0
IA	5	237	130	179	122	51.0	36.6	41.4	37.3	33.3	95.5	28.7	41.4	34.5	89.0	66.0	38.9	63.5

\* Maximum Proof Load is 2-1/2 times the Working Load Limit. Average straightening load (ultimate load) is 4 times the Working Load Limit.





# Sling Saver® Fittings / Accessories



**S-282  
WEB/CHAIN  
CONNECTOR**

Designed around the same concept as our S-280 Web Connector, the S-282 Chain Connector makes the connection from your web sling to existing chain quick and easy.

- Available in three sizes:
  - 2.95 tonnes Working Load Limit links 50mm Webbing to 10mm chain.
  - 4.08 tonnes Working Load Limit links 35mm (75mm Tapered Webbing) to 13mm chain.
  - 5.67 tonnes Working Load Limit links 50mm (100mm Tapered Webbing) to 16mm chain.
- Alloy Steel (Quenched and Tempered).
- Each Connector has a Product Identification Code (PIC) for material traceability along with a Working Load Limit and the name Crosby forged into it.
- Uses same spool and cover as S-280 Web Connector.
  - Replacement Kit for Spool and Web Cover available.
- No retaining pin to snag sling material.

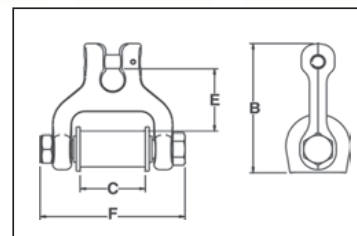

**Sling Saver®**

**Load Rated**



## S-282 Web / Chain Connector

Round Sling Size (No.)	Web Slings*			Chain Size	Working Load Limit (Tons) †	S-282 Stock No.	Weight Each (lbs.)	Dimensions (in.)			
	Webbing Width (in.)	Eye Width (in.)	Ply					B	C	E	F
1 & 2	2	2	2	3/8	3-1/4	1021084	1.9	4.33	2.13	2.11	4.77
3	3	1.5	2	1/2	4-1/2	1021093	2.8	5.04	1.63	2.44	4.54
4	4	2	2	5/8	6-1/4	1021100	4.3	5.69	2.13	2.54	5.31

\* NOTE: Designed for use with Type III, (Eye & Eye), Class 7, 2 Ply web slings. † Maximum Proof Load is 2 times the Working Load Limit. Minimum Ultimate Strength is 4 times the Working Load Limit.



**S-287  
CHOKER HOOK**

- Available in 2 sizes: 2.95 tonnes (50mm webbing) and 4.08 tonnes (75mm webbing)
- Forged Alloy Steel – Quenched & Tempered
- Design factor of 5 to 1.
- Each Connector has a Product Identification Code (PIC) for material traceability along with a Working Load Limit and the name Crosby forged into it.
- Special design of hook protects the synthetic sling when dropped or dragged.
- Designed to reduce friction, abrasion, and fraying in choker area.
- Uses same spool and cover as S-280 Web Connector.
  - Replacement Kit for Spool and Web Cover available.
- No retaining pin to snag sling material.

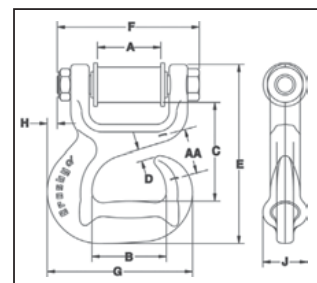

**Sling Saver®**



**Load Rated**



Crosby Sling Saver hardware meets the requirements for minimum stock diameter or thickness, and effective contact width shown in the Recommended Standards Specification for Synthetic Polyester Round Slings by the Web Sling & Tie Down Association. WSTDA-RS1 (revised 2010)

## S-287 Sliding Choker Hook

Round Sling Size (No.)	Web Slings*			Working Load Limit (t) †	S-287 Stock No.	Weight Each (kg)	Dimensions (mm)									
	Webbing Width (mm)	Eye Width (mm)	Ply				A	B	C	D	E	F	G	H	J	AA
1 & 2	50	50	2	2.95	1021909	1.68	54.0	63.5	84.5	9.65	153	121	124	8.65	38.1	38.1
3	75	35	2	4.08	1021918	2.77	41.4	89.0	93.0	9.65	179	115	165	34.5	47.8	—

\* NOTE: Designed for use with Type III, (Eye & Eye), Class 7, 2 Ply web slings. † Maximum Proof Load is 2 times the Working Load Limit. Minimum Ultimate Strength is 5 times the Working Load Limit.

**SLING SAVER FITTINGS**

# Sling Saver® Synthetic Sling Connectors



**S-237**

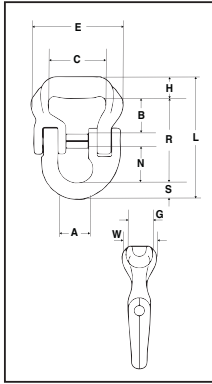

**High Performance Sling Connector is designed to connect High Performance Synthetic Slings.**

- Capacities available:
  - Working Load Limit (5 to 1): 2,268 through 27,215 kg.
  - Sling Body Widths: 51mm through 152mm.
- Allows easy connection to master links or eye hooks, and is ideal for bridles.
- Increased radius of bow gives wider sling bearing surface resulting in an increased area for load distribution, thus:
  - Increasing Synthetic Sling efficiency as compared to master links, shackle bows and conventional eye hooks. This allows 100% of the sling's rated Working Load Limit to be achieved.
  - Allows better load distribution on internal fibers.
- All Alloy Construction
- Design Factor of 5 to 1.
- Individually Proof Tested at 2.5 times the Working Load Limit.
- Each connector has a Product Identification Code (PIC) for material traceability, along with a frame size, and the name Crosby and USA in raised letters.



**S-238**

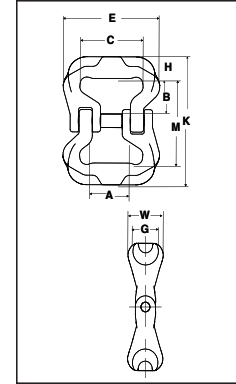

## S-237 High Performance Sling Connector

Working Load Limit		S-237 Web to Lok-A-Loy Assy. Stock No.	Frame No.	Nominal Sling Body Width (mm)	Lok-A-Loy Size (mm)	Weight Each (kg)	Dimensions (mm)										
4:1 (kg)*	5:1 (kg)						A	B	C	E	G	H	L	N	R	S	W
2835	2268	1020695	5	51	10	.52	22.4	36.1	50.8	80.8	25.4	20.3	107	26.4	74.2	12.2	35.1
5670	4536	1020704	10	76	16	1.34	36.1	38.6	69.9	105	31.8	24.9	144	43.4	100	19.0	44.5
8505	6804	1020713	15	76	20	2.15	41.4	40.1	69.9	111	35.1	27.9	165	51.8	113	23.6	47.8
14175	11340	1020722	25	102	22	3.90	50.8	59.2	95.3	152	44.5	35.8	202	57.7	140	26.9	57.2
17010	13607	1020731	30	102	22	4.19	50.8	55.9	95.3	157	44.5	35.8	199	57.7	137	26.9	60.5
22680	18145	1020740	40	127	25	7.1	57.2	73.9	121	184	57.2	45.2	240	62.0	164	31.0	78.5
34020	27215	1020759	60	152	32	11.8	65.0	85.3	146	232	58.7	47.2	281	78.0	196	38.1	80.3

\* Maximum Proof Load is 2 times the Working Load Limit at 4:1 design factor. Minimum Ultimate strength is 5 times the Working Load Limit.

## S-238 High Performance Sling Connector

Working Load Limit (kg)	S-238 Web to Web Assembly Stock No.	Frame No.	Nominal Sling Body Width (mm)	Weight Each (kg)	Dimensions (mm)								
					A	B	C	E	G	H	K	M	W
2268	1020415	5	50.8	.73	22.4	36.1	50.8	80.8	25.4	20.3	124	83.8	35.1
4536	1020423	10	76.2	1.50	36.1	38.6	69.9	105	31.8	24.9	145	95.5	44.5
6804	1020432	15	76.2	2.22	41.4	40.1	69.9	111	35.1	27.9	156	101	47.8
11340	1020441	25	102	4.58	50.8	59.2	95.3	152	44.5	35.8	213	142	57.2
13608	1020450	30	102	5.17	50.8	55.9	95.3	157	44.5	35.8	207	135	60.5
18144	1020469	40	127	9.39	57.2	73.9	121	184	57.2	45.2	266	176	78.5
27216	1020478	60	152	14.5	65.0	85.3	146	232	58.7	47.2	298	203	80.3

\* Maximum Proof Load is 2.5 times the Working Load Limit. Minimum Ultimate strength is 5 times the Working Load Limit.



Crosby Sling Saver hardware meets the requirements for minimum stock diameter or thickness, and effective contact width shown in the Recommended Standards Specification for Synthetic Polyester Round Slings by the Web Sling & Tie Down Association. WSTDA-RS1 (revised 2010)



# Sling Saver® High Performance Sling System



**Typical Application** The S-237 and S-238 connectors have been designed to easily adapt to other Crosby fittings to develop complete systems for high performance Synthetic Slings.

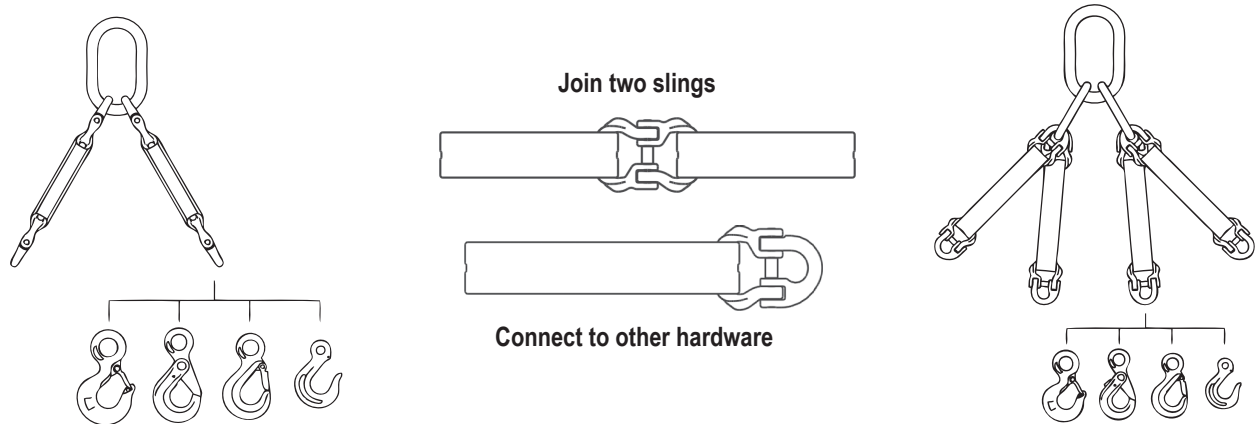

These easy-to-use charts are designed to allow you to quickly determine the Crosby Fitting required for your high performance sling.

## Single Leg Sling

S-237 Frame	Working Load Limit									
	4:1 (kg)*	5:1 (kg)	A-1337 Lok-A-Loy (mm)	A-342 (mm)	A-344 (mm)	(t)	Frame	S-1316 (mm)	S-315A (mm)	A-1327 (mm)
	5	2834	2268	10	25	22	†7	JA	16	16
10	5670	4536	16	25	22	†7	JA	16	16	16
15	8505	6804	20	32	25	†11	KA	19	–	19
25	14175	11340	22	38	32	†15	LA	22	–	22
30	17010	13607	22	38	32	†15	LA	22	–	22
40	22680	18145	25	44	–	†22	NA	25	–	–
60	34020	27215	32	51	–	30	OA	–	–	–

\* Ultimate load is 5 times the Working Load Limit. † S-320AN Style Hook.

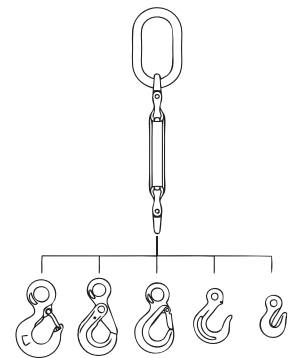

## Double Leg Sling

S-237 Frame	Working Load Limit									
	4:1 (kg)*	5:1 (kg)	A-1337 Lok-A-Loy (mm)	A-342 (mm)	A-344 (mm)	(t)	Frame	S-1316 (mm)	S-315A (mm)	A-1327 (mm)
	5	2834	2268	10	32	32	†7	JA	16	16
10	5670	4536	16	32	32	†7	JA	16	16	16
15	8505	6804	20	38	–	†11	KA	19	–	19
25	14175	11340	22	44	–	†15	LA	22	–	22
30	17010	13607	22	44	–	†15	LA	22	–	22
40	22680	18145	25	51	–	†22	NA	25	–	–
60	34020	27215	32	57	–	30	OA	–	–	–

\* Ultimate load is 5 times the Working Load Limit. † S-320AN Style Hook.

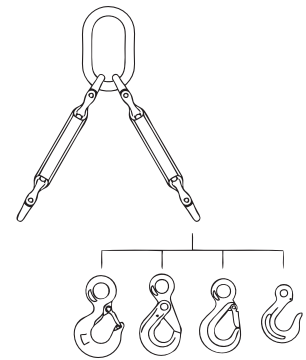

For Triple and Quad leg slings, contact Crosby Engineering at (918) 834-4611

**SLING SAVER FITTINGS**

# Sling Saver® Web Sling Systems

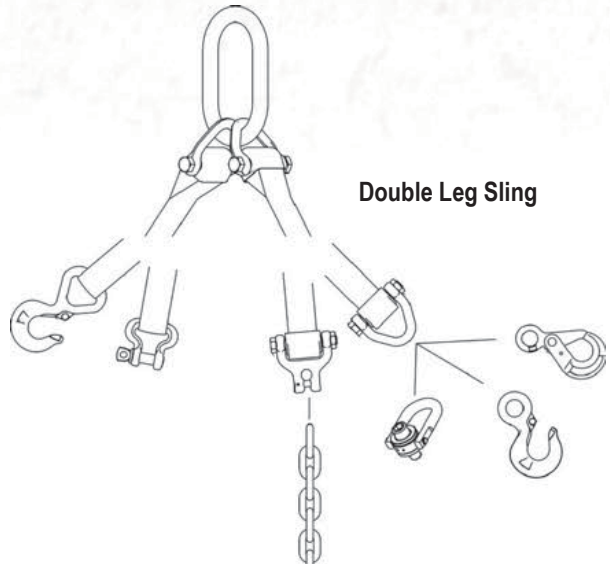
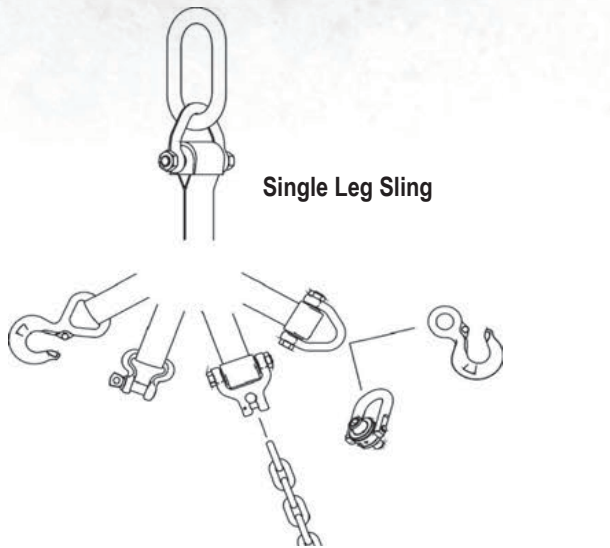

These easy-to-use charts are designed to allow you to quickly determine the fitting required to create the Web Sling or Round Sling you need.

## Single and Double Leg Slings Component Recommendations based on Type III, (Eye & Eye), Class 7, 2 Ply web slings.

S-280 Web Connector S-281 Web Sling Shackle S-282 Chain Connector					S-280 Web Connector							
Web Sling					Web Sling							
Round Sling Size (No.)	Web Width (mm)	Eye Width (mm)	Ply.	S-280 S-281 S-282 Working Load Limit (t)	Web Sling Hook WS-320 (t)	Spectrum 8® Chain Size (in.) – (mm)	Eye Hoist Hook S-320AN (t)	Eye SHUR-LOC® S-1316 (mm)	Swivel Hoist Ring HR-125 (kg)	Master Link A-342 Single Leg (mm)	Master Link A-342 Double Leg (mm)	
1 & 2	50	50	2	2.95	3	3/8 - 10	3.2	13	3000	16	19	
3	75	35	2	4.08	5	1/2 - 13	5.4	16	4200	19	25	
4	100	50	2	5.67	—	5/8 - 16	8	16	7000	25	25	
5 & 6	150	75	2	7.70	—	—	11.5	—	11000	25	32	

## Triple and Quad Leg Slings Component Recommendations based on Type III, (Eye & Eye), Class 7, 2 Ply web slings.

S-280 Web Connector S-281 Web Sling Shackle S-282 Chain Connector					S-280 Web Connector							
Web Sling					Web Sling							
Round Sling Size (No.)	Web Width (mm)	Eye Width (mm)	Ply.	S-280 S-281 S-282 Working Load Limit (t)	Web Sling Hook WS-320 (t)	Spectrum 8® Chain Size (in.) – (mm)	Eye Hoist Hook S-320AN (t)	Eye SHUR-LOC® S-1316 (mm)	Swivel Hoist Ring HR-125 (kg)	Master Link A-342 Triple Leg (mm)	Master Link A-342 Quad Leg (mm)	
1 & 2	50	50	2	2.95	3	3/8 - 10	3.2	13	3000	25	25	
3	75	35	2	4.08	5	1/2 - 13	5.4	16	4200	25	32	
4	100	50	2	5.67	—	5/8 - 16	8	16	7000	32	38	
5 & 6	150	75	2	7.70	—	—	11.5	—	11000	38	44	





# Easily Integrated into “Synthetic Sling System”



The “Synthetic Sling Saver” shackles line has been designed to easily adapt Crosby Sling fittings in the development of complete systems for synthetic slings.

## Single Leg Slings

Sling Saver Shackle							LOK-A-LOY® Link* A-1337				
Web Sling Eye Width (mm)	Working Load Limit (t)	Sling Saver Shackle Spool S-255 (mm)	Sling Saver Shackle Link Plate S-256 (mm)	Eye Hoist Hook S-320AN† S-320A (t)	Alloy Master Link A-342 (mm)	Master Link Assy. A-345 (mm)	Sling Hook A-1327 (mm)	Eye Grab Hook A-1328 (mm)	Eye Foundry Hook A-1329 (mm)	Eye SHUR-LOC® S-1316A (mm)	Eye Latching S-315A (mm)
25	3-1/4	25	25	†5.4	19	—	10	10	10	10	10
35	6-1/2	35	35	†8	25	—	16	16	16	16	16
50	8-3/4	50	50	†11.5	25	—	16	16	16	16	16
75	12-1/2	75	75	†16	32	—	19	19	19	—	19
100	20-1/2	100	100	†22	44	—	—	19	—	19	—
125	35	125	125	37	51	—	—	19	—	—	—
150	50	150	150	60	57	—	—	19	—	—	—

\* LOK-A-LOY® size same as hook size. † New 320N Eye Hook.

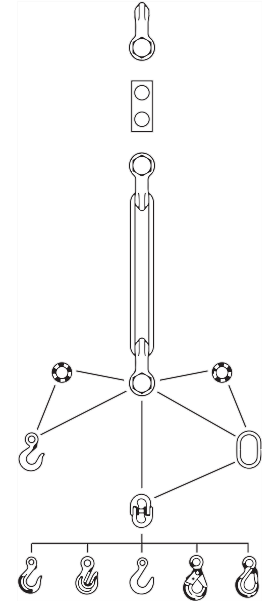

Single Leg Sling

## Double Leg Slings

Sling Saver Shackle							LOK-A-LOY® Link* A-1337				
Web Sling Eye Width (mm)	Working Load Limit (t)	Sling Saver Shackle Spool S-255 (mm)	Sling Saver Shackle Link Plate S-256 (mm)	Eye Hoist Hook S-320AN† S-320A (t)	Alloy Master Link A-342 (mm)	Master Link Assy. A-345 (mm)	Sling Hook A-1327 (mm)	Eye Grab Hook A-1328 (mm)	Eye Foundry Hook A-1329 (mm)	Eye SHUR-LOC® S-1316A (mm)	Eye Latching S-315A (mm)
25	3-1/4	25	25	†5.4	19	25	10	10	10	10	10
35	6-1/2	35	35	†8	25	32	16	16	16	16	16
50	8-3/4	50	50	†11.5	25	32	16	16	16	16	16
75	12-1/2	75	75	†16	32	38	19	19	19	—	19
100	20-1/2	100	100	†22	44	44	—	—	—	—	—
125	35	125	125	37	51	—	—	—	—	—	—
150	50	150	150	60	57	—	—	—	—	—	—

\* LOK-A-LOY size same as hook size. † New 320N Eye Hook.

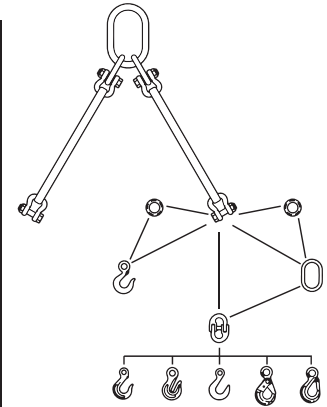

Double Leg Sling

SLING SAVER FITTINGS

**WEB SLINGS**

SHALL NOT BE CONSTRICTED OR BUNCHED BETWEEN THE EARS OF A CLEVIS OR SHACKLE, OR IN A HOOK.

**ROUND SLINGS**

SHALL NOT BE CONSTRICTED OR BUNCHED BETWEEN THE EARS OF A CLEVIS OR SHACKLE, OR IN A HOOK.

THE OPENING OF FITTINGS SHALL BE PROPER SHAPE AND SIZE TO ENSURE THAT THE FITTING WILL SEAT PROPERLY ON THE ROUND SLING.

WHEN A ROUND SLING IS USED WITH A SHACKLE, IT IS RECOMMENDED THAT IT BE USED (RIGGED) IN THE BOW OF THE SHACKLE.

**SYNTHETIC SLINGS RATED LOAD**

FOLDING, BUNCHING OR PINCHING OF SYNTHETIC SLINGS, WHICH OCCURS WHEN USED WITH SHACKLES, HOOKS OR OTHER APPLICATION WILL REDUCE THE RATED LOAD.

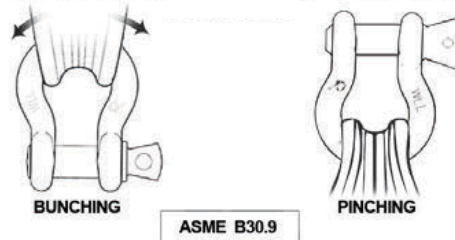

When connecting Web or Round Slings, use conventional fittings with:  
 1. Large Radius. 2. Straight Pins. 3. Pads or use special fittings designed for Synthetic Slings.

## SYNTHETIC SLING CONNECTIONS AND HITCHES

**WEB SLING IDENTIFICATION INCLUDES:**

**SLING TYPE:**

- TC – TRIANGLE CHOKER
- TT – TRIANGLE TRIANGLE
- EE – EYE AND EYE
- EN – ENDLESS

**NUMBER OF PLYS:** 1 OR 2

**WEBBING GRADE:** 9 OR 6

**SLING WIDTH (INCH)**

**EE 2-9 100 x 305 ← SLING LENGTH (INCH)**

**ROUND SLING IDENTIFICATION INCLUDES:**

**SLING NUMBER: 1-13**

SLING NUMBERS ARE FOR REFERENCE ONLY. SOME ROUND SLINGS HAVE DIFFERENT RATINGS.

**SLING COLOR:** PURPLE, GREEN, YELLOW, TAN, RED, WHITE, BLUE, ORANGE

SLING COLOR IS NOT FOLLOWED BY ALL MANUFACTURERS, AND SOME COLORS HAVE MORE THAN ONE RATED LOAD.

FOLDING, BUNCHING OR PINCHING OF SYNTHETIC SLINGS, WHICH OCCURS WHEN USED WITH SHACKLES, HOOKS OR OTHER APPLICATION WILL REDUCE THE RATED LOAD.

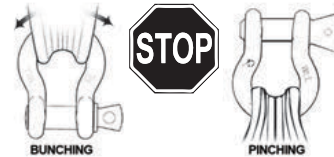

**CHOKER CAPACITY**

A CHOKER HITCH HAS 80% OF THE CAPACITY OF A SINGLE LEG SLING ONLY IF THE ANGLE OF CHOKE IS 120 DEGREES OR GREATER. A CHOKE ANGLE LESS THAN 120 DEGREES WILL RESULT IN A CAPACITY AS LOW AS 40% OF THE SINGLE LEG.

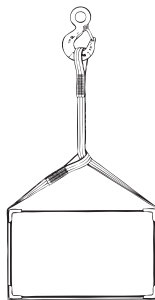

**BASKET HITCH CAPACITY**

HORIZONTAL ANGLE	CAPACITY % OF SINGLE LEG
90	200%
60	170%
45	140%
30	100%

A TRUE BASKET HITCH HAS TWICE THE CAPACITY OF A SINGLE LEG ONLY IF THE LEGS ARE VERTICAL.

**MULTIPLE LEG SLINGS**

**TRIPLE LEG SLINGS** HAVE 50% MORE CAPACITY THAN DOUBLE LEG SLINGS (AT SAME SLING ANGLE) ONLY IF THE CENTER OF GRAVITY IS IN CENTER OF CONNECTION POINTS AND LEGS ADJUSTED PROPERLY (THEY MUST HAVE AN EQUAL SHARE OF THE LOAD).

**QUAD (4-LEG) SLINGS** OFFER IMPROVED STABILITY BUT PROVIDE INCREASED CAPACITY ONLY IF ALL LEGS SHARE AN EQUAL SHARE OF THE LOAD.

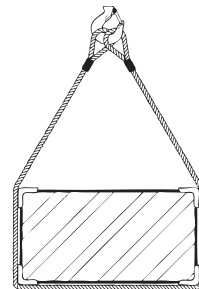

ALWAYS SELECT AND USE WEB SLINGS AND ROUND SLINGS BY THE RATED LOAD SHOWN ON THE SLING IDENTIFICATION TAG, NEVER BY WIDTH, COLOR OR SLING NUMBER.





# HOOKS & SWIVELS

With Product Warnings and Application Information





S-320N



# "There is No Equal"

The Market Leader: Yesterday Today and Tomorrow



S-319N

## Hooks & Swivles

### DESIGN

The theoretical reserve capability of a hoist hook should be a minimum of 5 to 1 for carbon eye hooks, alloy eye hooks and carbon shank hooks and 4.5 to 1 for alloy shank hooks. Known as the DESIGN FACTOR, it is usually computed by dividing the catalog ultimate load by the working load limit. The ultimate load is the average load or force at which the product fails or no longer supports the load. The working load limit is the maximum mass or force which the product is authorized to support in general service. The design factor is generally expressed as a ratio such as 5 to 1. Also important to the design of hooks is the selection of proper steel.

### THE COMPETITION

- Ask:** What is the the design factor?
- Ask:** Is production lot performance tested?



Crosby hoist hooks meet the design factor requirements of 5 to 1 for all carbon hooks, 5 to 1 for all alloy eye and swivel hooks and 4.5 to 1 for alloy shank hooks. Crosby's QC 1400 program determines the mechanical properties of each manufacturing lot of hoist hooks. In addition to the heat treat process, Crosby hooks are designed with a cross section that, when overloaded, allows uniform deformation and straightening before ultimate failure.

### QUENCHED AND TEMPERED

Quenching and tempering assures the uniformity of performance and maximizes the properties of the steel. This means that each hook meets its rated strength and other properties. This quenching and tempering process develops a tough material that reduces the risk of a brittle, catastrophic failure, thus improving impact and fatigue properties. As a result, if overloaded, the hook will deform before ultimate failure occurs, thus giving warning. The requirements of your job demand this reliability and consistency. Quench and Tempering insures that not only is the working load limit met, but that ductility, fatigue and impact properties are appropriate.

### THE COMPETITION

- Ask:** Are their hooks quenched and tempered?
  - Ask:** Do their shackles have good fatigue life?
  - Ask:** Do their shackles have a fatigue life that meets the new world standards?
- Some competitors normalize the hooks, and as a result, desired properties are not achieved. A few even provide hooks in an "as forged" condition, which can result in brittle failure.



Crosby hoist hooks are quenched and tempered. This heat treatment process assures a hook that will deform prior to ultimate failure. Impact and fatigue properties are superior with quenched and tempered hooks. Crosby's Quenched and Tempered carbon and alloy hoist hooks are recommended for all critical applications, including overhead lifting.



### FULL LINE AND IDENTIFICATION

The proper application of hoist hooks requires that the correct type, size, and working load capacity of hook be used. All hooks must be load rated (with either the working load or a cross reference code). In addition the traceability code, size, and manufacturer's name should be boldly marked on the product. Availability of a full line of eye, shank, and swivel hooks in carbon and alloy steel is essential when selecting the desired hook for the proper application.

### THE COMPETITION

- Ask:** Do they have a traceability system?
  - Ask:** Does their traceability system tie into a comprehensive material testing program?
  - Ask:** Does their product offering cover the full range?
- Most competitors do not have the full line of hooks that Crosby produces. Most do not have a traceability system.



Crosby forges "Crosby" or "CG," the Product Identification Code (P.I.C.), and working load limit (or working load cross reference code) into its full line. Crosby's traceability system and P.I.C. are an integral part of the QC 1400 program.



### APPLICATION INFORMATION

Detailed application information will assist you in the proper selection and use of hoist hooks. This information is most effective when provided in supporting brochures and engineering information. A formal application and warning system that attracts the attention of the user, clearly informs the user of the factors involved in the task, and informs the user of the proper application procedures is needed.

### THE COMPETITION

- Ask:** Do they provide hook application and warning information attached directly to the hook?
  - Ask:** What training support is provided?
- Most competitors do not have a comparable product warnings system and application information for hoist hooks.



The Crosby Product Warnings System provides detailed application and warning information for hoist hooks. In addition, a video on hook maintenance is also available. Field inspection criteria and repair instructions are also available. Training seminars conducted by Crosby provide training on the proper use of hoist hooks. Crosby training packets, supplied free to attendees of Crosby's seminars, provide training materials needed to explain the proper use of hoist hooks.

Remember: "When buying Crosby, you're buying more than product, you're buying Quality."



# Crosby® VALUE ADDED

- **U.S. ratings:** When comparing to other hooks which are rated in short tons, the design factor of Crosby hooks (in short tons) is 5 to 1 for all carbon hooks, 5 to 1 for alloy eye and swivel hooks, 4.5 to 1 for alloy shank hooks and 4 to 1 for all bronze hooks.
- **Application information:** Application and warning information is available for Crosby hoist hooks. The Crosby Warning System is designed to attract the attention of the user, clearly inform the user of the factors involved in the task, and provide the user with proper application procedures. Each Crosby hoist hook is tagged with appropriate application and warning information, thus insuring that the information is available at the point of application.
- **Charpy impact properties:** Crosby's quenched and tempered hooks have enhanced impact properties for greater toughness at all temperatures. Crosby can provide typical Charpy impact properties on selected sizes upon special request at the time of order.
- **Fatigue properties:** Typical fatigue properties are available for selected sizes. In addition, these properties will be provided upon special request for other sizes.
- **Ductility properties:** Crosby's QC 1400 program provides results of actual test values for ductility of the material. These results are measured by reduction of area and elongation. This is done for each production lot and is traceable by the Product Identification Code (PIC).
- **Tensile strengths:** Crosby's QC 1400 program provides hardness, tensile, and yield strength for each production lot of hoist hooks. They are traceable by the Product Identification Code (PIC).
- **Material Analysis:** Crosby can provide certified material (mill) analysis for each production lot, traceable by the Product Identification Code (PIC). Crosby, through its own laboratory, verifies the analysis of each heat of steel. Crosby purchases only *special bar* forging quality steel with specific cleanliness requirements and guaranteed hardenability.
- **Field inspection:** Written instructions for visual, magnaflux, and dye penetrant inspection of hooks are available from Crosby. In addition, acceptance criteria and repair procedures for hooks are available.
- **Proof testing:** If requested at the time of order, hooks can be furnished proof tested with certification. All SHUR-LOC® hooks (clevis and eye styles) are 100% proof tested with certificates.
- **Mag Certification:** If requested at the time of order, hooks can be Mag inspected with certification.
- **World Class Certification:** Certification to World Class Standards can be furnished upon request at the time of order. Specific standards include American Bureau of Shipping, Lloyds Register of Shipping, Det Norske Veritas, American Petroleum Institute, RINA, Nuclear Regulatory Commission, and other worldwide standards.
- **Bronze Hooks:** Crosby provides bronze shank hooks for non-sparking applications.
- **QUIC-CHECK®:** Hoist hooks incorporate markings forged into the product which address two (2) QUIC-CHECK® features: *Deformation Indicators:* Two strategically placed marks, one just below the shank or eye and the other on the hook tip, which allows for a QUIC-CHECK® measurement to determine if the throat opening has changed, thus indicating abuse or overload. *Angle Indicators:* Indicates the maximum included angle which is allowed between two (2) sling legs in the hook. These indicators also provide the opportunity to approximate other included angles between two sling legs.
- **McKissick Split-Nut Hook Retention System:** Shank hooks on crane blocks must be inspected in accordance with applicable ASME B30, CSA Z150 and other crane standards. These standards mandate the crane hook to be inspected for surface indications, damage and corrosion which could compromise the integrity of the crane block. Because of the type of environment in which these hooks are required to perform, the removal of corroded nuts from the threads can become a problem during inspections. The innovative patented McKissick Split-Nut Retention System is available on Crosby shank hoist hooks. With 4 easy steps, the hook can be disassembled, inspected and put back into service in a fraction of the time of a conventional threaded nut.

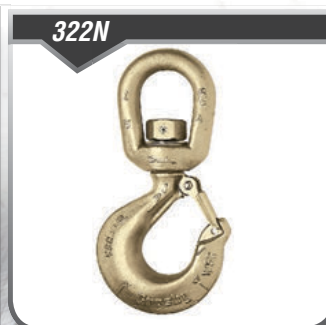

Scan this QR code with your smart device to view our Split-Nut Retention System video.



**S-319/S-319N**

Trademark indicates  
QUIC-CHECK® product.

Hook Material

Codes: A-Alloy Steel,  
B-Bronze High Strength,  
C-Carbon Steel.

- The most complete line of shank hoist hooks. Available 3/4 to 300 metric tons.
- Hook Identification code forged into each hook.
- Quenched and Tempered.
- Available in carbon steel, alloy steel, and bronze.
- Proper design, careful forging, and precision controlled quench and tempering give maximum strength without excessive weight and bulk.
- Every Crosby Shank Hook has a pre-drilled cam which can be equipped with a latch. Simply purchase the latch assemblies listed and shown on pages 123 - 125. Even years after purchase of the original hook, latch assemblies can be added.
- Type Approval and certification in accordance with ABS 2006 Steel Vessel Rules 1-1-17.7, and ABS Guide for Certification of Cranes.
- Patented McKissick Split-Nut retention system available, see page 373 for more information.



**SEE APPLICATION AND WARNING INFORMATION**

Crosby On Pages 142 - 143  
McKissicks On Pages 144-145  
Para Español: www.thecrosbygroup.com

**S-319 / S-319N Crosby® Shank Hook**

Working Load Limit (t)*			Hook ID Code	Shank Hooks Stock No.			Shank Length ‡	Weight Each (kg)	Rep. Latch Kits		
Carbon	Alloy	Bronze		Carbon S-319C S-319CN	Alloy S-319A S-319AN	Bronze S-319BN			S-4320 Stock No.	PL Stock No.	SS-4055 Stock No.
3/4	1.25	.5	†D	1028505	1028701	1028900	Std.	.23	1096325	-	-
1	1.6	.6	†F	1028514	1028710	1028909	Std.	.34	1096374	-	-
1.6	2.5	1	†G	1028523	1028723	1028918	Std.	.45	1096421	-	-
2	3.2	1.4	†H	1028532	1028732	1028927	Std.	.83	1096468	-	-
3.2	5.4	2	†I	1028541	1028741	1028936	Std.	1.67	1096515	1092000	-
5	8	3.5	†J	1028550	1028750	1028945	Std.	3.29	1096562	1092001	-
7.5	11.5	5	†K	1028563	1028765	1028954	Std.	6.12	1096609	1092002	-
10	16	6.5	†L	1028590	1028792	1028981	Std.	9.9	1096657	1092003	-
15	22	10	†N	1028599	1028801	1028990	Std.	17.4	1096704	1092004	-
20	30	-	O	1024386	1024803	-	Std.	32.7	-	1093716	1090161
20	30	-	O	1024402	1024821	-	Long	38.8	-	1093716	1090161
25	37	-	P	1024420	1024849	-	Std.	61	-	1093717	1090189
25	37	-	P	1024448	1024867	-	Long	78	-	1093717	1090189
30	45	-	S	1024466	1024885	-	Std.	83	-	1093718	1090189
30	45	-	S	1024484	1024901	-	Long	97	-	1093718	1090189
40	60	-	T	1024509	1024929	-	Std.	122	-	1093719	1090205
40	60	-	T	1024545	1024965	-	Long	142	-	1093719	1090205
50	75	-	U	1024563	1024983	-	Std.	177	-	1093720	-
50	75	-	U	1024581	1025009	-	Long	193	-	1093720	-
-	100	-	W	-	1025027	-	Std.	277	-	1093721	-
-	100	-	W	-	1025045	-	Long	306	-	1093721	-
-	150	-	X	-	1025063	-	Std.	333	-	1093721	-
-	200	-	Y	-	1025081	-	Std.	463	-	1093723	-
-	300	-	Z	-	1025090	-	Std.	630	-	1093724	-

Proof Load is 2 Times Working Load Limit. All carbon hooks designed with a 5/1 design factor. All alloy hooks 1-22t designed with a 4.5/1 design factor. All alloy hooks 30t and larger designed with a 4/1 design factor. All bronze hooks designed with a 4/1 design factor. † New 319N style hook. ‡ See column "Y" on following page for actual length.



# Crosby® Shank Hooks



- Hoist hooks incorporate markings forged into the product which address two (2) QUIC-CHECK® features.
  - **Deformation Indicators** -- Two strategically placed marks, one just below the shank or eye and the other on the hook tip, which allows for a **QUIC-CHECK®** measurement to determine if the throat opening has changed, thus indicating abuse or overload. To check, use a measuring device (i.e. tape measure) to measure the distance between the marks. The marks should align to either an inch or half-inch increment on the measuring device. If the measurement does not meet this criteria, the hook should be inspected further for possible damage.
  - **Angle Indicators** -- Indicates the maximum included angle which is allowed between two (2) sling legs in the hook. These indicators also provide the opportunity to approximate other included angles between two sling legs.
- Chemical analysis and tensile tests performed on each PIC to verify chemistry and mechanical properties.

## S-319/S-319N

Trademark indicates QUIC-CHECK® product.  
 Hook Material  
 Codes: A-Alloy Steel,  
 B-Bronze High Strength,  
 C-Carbon Steel.

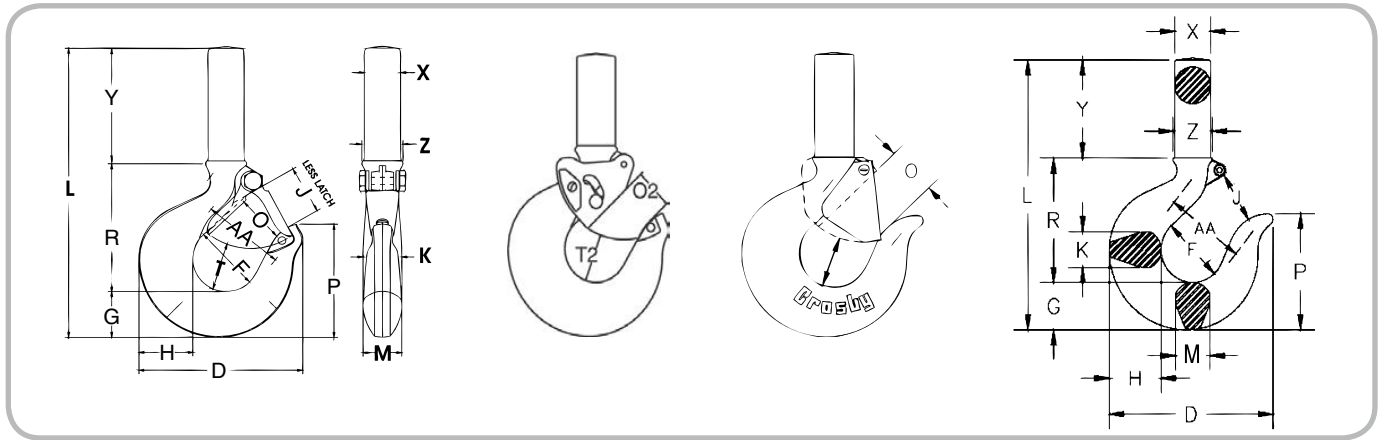

## S-319 / S-319N Crosby® Shank Hook

Hook ID Code	Dimensions (mm.)																	
	D	F	G	H	J	K	L	M	O	O2 ††	P	R	T	T2 ††	X	Y	Z	AA**
D	72.5	31.8	18.5	20.6	23.6	16.0	131	16.0	†23.6	-	49.8	59.5	24.6	-	15.0	52.5	17.5	38.1
F	80.5	35.1	21.3	23.9	24.6	18.0	144	18.0	†24.6	-	56.5	66.0	24.6	-	16.8	57.0	19.8	50.8
G	91.0	38.1	25.4	29.5	26.9	22.4	161	22.4	†26.9	-	62.0	70.0	26.2	-	18.3	66.0	22.4	50.8
H	102	41.1	29.0	33.3	30.2	23.9	181	23.9	†29.5	-	70.5	80.5	29.5	-	22.4	72.0	25.4	50.8
I	123	51.0	36.6	41.4	38.1	33.3	219	28.7	†34.5	25.4	88.0	98.0	38.9	38.1	29.5	87.5	31.8	63.5
J	160	63.5	46.2	52.5	45.2	42.2	265	36.6	40.9	33.3	117	121	49.3	47.8	35.8	97.5	39.6	76.2
K	192	76.0	57.5	67.0	61.0	47.8	318	41.4	53.0	46.0	133	149	62.5	57.2	46.0	111	49.3	101
L	212	82.5	66.0	74.5	66.5	55.5	409	49.3	57.5	51.0	151	162	66.0	58.7	51.0	178	55.5	101
N	263	108	76.5	89.0	86.5	68.5	461	60.5	76.5	69.9	175	207	71.5	65.0	65.0	178	67.0	127
O	346	127	92.0	117	102	76.0	586	76.0	82.5	-	223	240	87.5	-	79.0	254	79.0	165
O	346	127	92.0	117	102	76.0	790	76.0	82.5	-	223	240	87.5	-	79.0	457	79.0	165
P	357	137	116	127	108	92.0	816	76.0	76.0	-	287	318	98.5	-	102	381	102	177
P	357	137	116	127	108	92.0	1044	76.0	76.0	-	287	318	98.5	-	102	610	102	177
S	392	152	129	140	121	94.5	867	82.5	86.0	-	319	356	121	-	106	381	106	203
S	392	152	129	140	121	94.5	1095	82.5	86.0	-	319	356	121	-	106	610	106	203
T	470	178	152	165	146	113	916	99.5	105	-	375	395	145	-	114	368	114	254
T	470	178	152	165	146	113	1208	99.5	105	-	375	395	145	-	114	660	114	254
U	524	197	170	184	165	133	1045	108	124	-	420	492	152	-	127	381	127	292
U	524	197	170	184	165	133	1249	108	124	-	420	492	152	-	127	584	127	292
W	584	173	218	251	149	140	1070	140	114	-	438	468	178	-	178	381	178	305
W	584	173	218	251	149	140	1222	140	114	-	438	468	178	-	178	533	178	305
X	619	171	232	278	152	152	1162	152	114	-	457	467	178	-	184	457	184	330
Y	678	191	248	300	168	178	1283	178	127	-	502	521	203	-	203	508	203	330
Z	765	241	270	329	203	184	1389	203	159	-	576	597	210	-	241	508	241	381

Rough as forged dimension. Shank will not machine to this dimension. Please refer to page 147 for recommended shank diameter when machining. \*\* Deformation Indicators. † 3/4" - 22A dimensions shown are for S-4320 Latch Kits. Dimensions for sizes 20 ton carbon and larger are for PL Latch Kits. †† Dimensions are for PL-N latch kits. For the purpose of calculating D/d ratio, utilize dimension M.



**S-320  
EYE HOOK**



**S-320N  
EYE HOOK**

**All Crosby 320 Eye Hoist Hooks incorporate the following features:**

- The most complete line of Eye hoist hooks.
- Available in carbon steel and alloy steel.
- Designed with a 5:1 Design Factor for (Carbon Steel); 4.5:1 Design Factor for 30t - 60t (Alloy Steel).
- Eye hooks are load rated.
- Proper design, careful forging and precision controlled quenched and tempering give maximum strength without excessive weight and bulk.
- Every Crosby Eye Hook has a pre-drilled cam which can be equipped with a latch. Even years after purchase of the original hook, latch assemblies can be added. (See pages 123 - 125)
- Chemical analysis and tensile tests performed on each PIC to verify chemistry and mechanical properties.
- Type Approval and certification in accordance with ABS 2011 Steel Vessel Rules 1-1-17.7, and ABS 2007 Guide for Certification of Cranes.
- Hoist hooks incorporate two types of strategically placed markings forged into the product which address two (2) **QUIC-CHECK®** features:
  - Deformation Indicators and Angle Indicators (see following page for detailed definition).

**The following additional features have been incorporated in the new Crosby S-320N Eye Hoist Hooks. (Sizes 3/4 metric ton Carbon through 22 metric ton Alloy.)**

- Metric Rated at 5:1 Design Factor for (Carbon Steel); 5:1 Design Factor for 1t - 22t (Alloy Steel).
- Can be proof tested to 2 times the Working Load Limit.
- Low profile hook tip.
- New integrated latch (S-4320) meets the world-class standard for lifting.
  - Heavy duty stamped latch interlocks with the hook tip.
  - High cycle, long life spring.
  - When secured with proper cotter pin through the hole in the tip of hook, meets the intent of OSHA Rule 1926.1431(g) and 1926.1501(g) for personnel hoisting.



**S-320 / S-320N EYE HOOKS**

Working Load Limit (t)		Hook ID Code	Eye Hook Stock No.					Weight Each (kg.)	Replacement Latch Kits		
Carbon	Alloy		Carbon S-320C S.C.	Carbon L-320CN S.C.	Carbon G-320CN Galv.	Alloy S-320A S-320AN S.C.	Alloy L-320A L-320AN S.C.		S-4320 Stock No.	PL Stock No.	SS-4055 Stock No.
.75	1.25	†D	1022200	1022205	1022208	1022375	1022380	.28	1096325	-	-
1	1.6	†F	1022211	1022216	1022219	1022386	1022391	.40	1096374	-	-
1.6	2.5	†G	1022222	1022227	1022230	1022397	1022402	.65	1096421	-	-
2	3.2	†H	1022233	1022238	1022241	1022406	1022413	.94	1096468	-	-
3.2	5.4	†I	1022244	1022246	1022249	1022419	1022424	1.95	1096515	1092000	-
5	8	†J	1022255	1022260	1022262	1022430	1022435	3.76	1096562	1092001	-
7.5	11.5	†K	1022264	1022271	1022274	1022441	1022446	6.80	1096609	1092002	-
10	16	†L	1022277	1022282	1022285	1022452	1022457	9.42	1096657	1092003	-
15	22	†N	1022288	1022293	1022296	1022465	1022468	17.9	1096704	1092004	-
20	31.5	O	1023289	1022302	-	1023546	1022477	27.2	-	1093716	1090161
25	37	P	1023305	-	-	1023564	-	47.6	-	1093717	1090189
30	45	S	1023323	-	-	1023582	-	67	-	1093718	1090189
40	60	T	1023341	-	-	1023608	-	103	-	1093719	1090205

\*Eye Hooks (3/4 TC - 22TA), Proof load is 2 times Working Load Limit. Eye Hooks (20 TC - 60TA). All carbon hooks-average straightening load (ultimate load) is 5 times Working Load Limit. Alloy eye hooks 1 ton through 22 ton-average straightening load (ultimate load) is 5 times Working Load Limit. Alloy eye hooks 30 tons through 60 tons-average straightening load (ultimate load) is 4.5 times Working Load Limit. † New 320N style hook.



# Crosby® Eye Hooks



**S-320N  
EYE HOOK**

- Hoist hooks incorporate markings forged into the product which address two (2) QUIC-CHECK® features.
  - **Deformation Indicators** -- Two strategically placed marks, one just below the shank or eye and the other on the hook tip, which allows for a **QUIC-CHECK®** measurement to determine if the throat opening has changed, thus indicating abuse or overload. To check, use a measuring device (i.e. tape measure) to measure the distance between the marks. The marks should align to either an inch or half-inch increment on the measuring device. If the measurement does not meet this criteria, the hook should be inspected further for possible damage.
  - **Angle Indicators** -- Indicates the maximum included angle which is allowed between two (2) sling legs in the hook. These indicators also provide the opportunity to approximate other included angles between two sling legs.

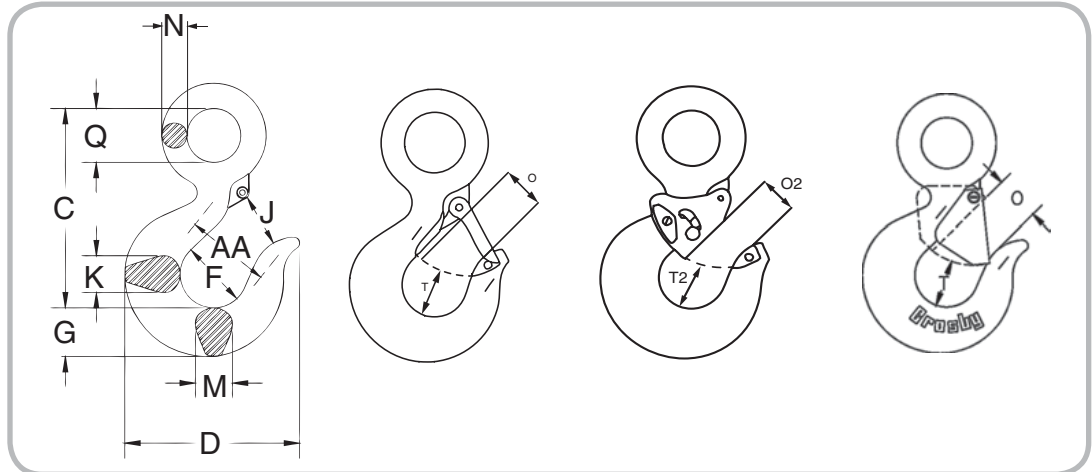

**Load Rated**

**Fatigue Rated**



**SEE APPLICATION AND WARNING INFORMATION**  
 On Pages 144 - 145  
 Para Español: [www.thecrosbygroup.com](http://www.thecrosbygroup.com)

## S-320 / S-320N EYE HOOKS

Hook ID Code*	Dimensions (mm)													
	C	D	F	G	J	K	M	N	O †	O2 ††	Q	T †	T2 ††	AA**
D	85.0	72.0	31.8	18.5	22.9	16.0	16.0	9.14	22.6	-	19.1	22.1	-	38.1
F	97.0	79.0	35.1	21.3	23.6	18.0	18.0	10.7	23.1	-	23.1	24.9	-	50.8
G	105	89.5	38.1	25.4	25.4	22.4	22.4	14.0	25.4	-	28.7	26.2	-	50.8
H	119	101	41.4	28.7	28.7	23.9	23.8	14.7	27.7	-	31.8	29.5	-	50.8
I	147	122	51.0	36.6	37.3	33.3	33.3	18.3	34.5	25.4	39.6	38.9	38.1	63.5
J	187	159	63.5	46.0	44.5	42.2	42.2	22.9	40.9	33.3	51.0	49.8	47.7	76.2
K	230	189	76.0	57.0	58.0	47.8	41.4	28.2	53.0	46.0	62.0	62.5	57.2	102
L	256	211	82.5	66.0	63.5	55.5	49.3	32.3	57.5	51.0	72.0	66.5	58.7	102
N	318	262	108	76.0	84.0	68.5	60.5	39.6	76.5	69.8	89.0	72.0	65.0	127
O	357	346	127	92.0	102	76.0	76.2	44.5	82.5	-	89.0	87.5	-	165
P	462	357	137	116	108	95.2	81.0	51.0	76.0	-	114	98.5	-	178
S	511	392	152	129	121	114	82.6	55.4	86.0	-	125	121	-	203
T	602	470	178	152	146	140	99.3	64.3	105	-	145	145	-	254

\* Eye Hooks (3/4 TC-22TA), Proof load is 2 times Working Load Limit. Eye Hooks (20 TC-60TA). All carbon hooks - average straightening load (ultimate load) is 5 times Working Load Limit. Alloy eye hooks 1t through 22t - average straightening load (ultimate load) is 5 times Working Load Limit. Alloy eye hooks 30t through 60t - average straightening load (ultimate load) is 4.5 times Working Load Limit.

\*\* Deformation Indicators.

† 3/4tC - 22tA dimensions shown are for S-4320 Latch Kits. Dimensions for sizes 20t carbon and larger are for PL Latch Kits.

†† Dimensions are for PL-N latch kits.



**S-322 / S-322AN**  
(L-322AN Shown)

- Forged - Quenched and Tempered.
- Swivel hooks are load rated.
- Proper design, careful forging, and precision controlled quench and tempering gives maximum strength without excessive weight and bulk.
- Low profile hook tip designed to utilize Crosby S-4320 or PL-N latch kit. Simply purchase the latch assemblies listed and shown on pages 119 - 120. Even years after purchase of the original hook, latch assemblies can be added.
- Hoist hooks incorporate markings forged into the product which address two (2) **QUIC-CHECK®** features:
  - **Deformation Indicators** -- Two strategically placed marks, one just below the shank or eye and the other on the hook tip, which allows for a QUIC-CHECK® measurement to determine if the throat opening has changed, thus indicating abuse or overload.
  - **Angle Indicators** — Indicates the maximum included angle which is allowed between two (2) sling legs in the hook. These indicators also provide the opportunity to approximate other included angles between two sling legs.
- Type Approval and certification in accordance with ABS 2007 Steel Vessel Rules 1-1-17.7, and ABS Guide for Certification of Cranes.

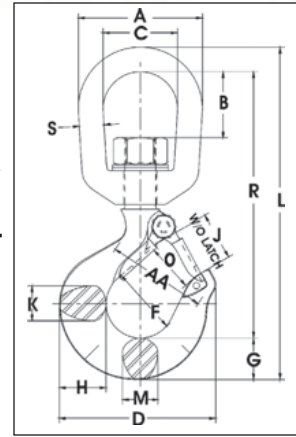

This hook is a positioning device and is not intended to rotate under load. For swivel hooks designed to rotate under load, see pages 121, 129, 130, 138-141. Use in corrosive environment requires shank and nut inspection in accordance with ASME B30.10-1.10.4(b)(5)(c) 2009.

**S-322CN Swivel Hooks**

Working Load Limit (t)*		S-322 CN Stock No.	S-322 AN Stock No.	Weight Each (lbs.)	Dimensions (mm)														Rep. Latch Stock No.	
Carbon	Alloy				A	B	C	D	F	G	H	J	K	L	M	O †	R	S		AA**
.75	1.25	1048600	1048804	.34	51.0	20.8	31.8	72.5	31.8	18.5	20.6	23.6	16.0	144	16.0	23.6	116	9.65	38.1	1096325
1	1.60	1048609	1048813	.57	63.5	33.3	38.1	80.0	35.1	21.3	23.9	24.6	18.0	170	18.0	24.6	136	12.7	50.8	1096374
1.6	2.50	1048618	1048822	1.02	76.0	38.1	44.5	91.0	38.1	25.4	29.5	26.9	22.4	197	22.4	26.9	155	16.0	50.8	1096421
2	3.20	1048627	1048831	1.04	76.0	38.1	44.5	102	41.1	28.7	33.3	30.2	23.9	210	23.9	29.5	165	16.0	50.8	1096468
3.2	5.4	1048636	1048837	2.25	89.0	41.7	50.8	123	51.0	36.6	41.4	38.1	33.3	246	28.7	35.8	191	19.1	63.5	1096515
5	8.0	1048645	1048854	4.67	116	58.0	63.5	160	63.5	46.0	52.5	45.2	42.2	317	36.6	42.9	245	25.4	76.2	1096562
7.5	11.5	1048654	1048865	8.80	127	62.0	70.0	192	76.0	57.0	67.0	51.0	47.8	375	41.4	56.5	289	28.7	101	1096609
10	16	1048663	1048877	10.5	143	63.0	79.0	212	82.5	66.0	74.5	66.5	55.5	417	49.3	61.0	311	31.8	101	1096657
15	22	1048672	1048886	21.3	180	95.5	104	263	108	76.0	89.0	86.5	68.5	542	60.5	81.0	424	38.1	127	1096704
-	31.5	-	1025688	32.0	180	95.5	104	346	127	93.0	118	102	72.5	590	76.2	82.6	459	38.1	165	1093716

\* Carbon swivel hooks .75tC-15tC: proof load is 2 times working load limit. Designed with a 5 to 1 safety factor. Alloy swivel hooks 1.25tA-31.5tA : proof load is 2.5 times working load limit. Designed with a 4 to 1 safety factor. Alloy swivel hook 30tA: proof load is 2 times working load limit. Designed with a 4 to 1 design factor. \*\* Deformation Indicators. † Dimensions for hooks 3/4t carbon thru 22t alloy are for S-4320 latch kits. Dimensions for hooks 31.5 ton alloy are for PL latch kit.

**S-322AN Swivel Hooks**

Working Load Limit (t)*		L-322 CN Stock No.	L-322 AN Stock No.	Weight Each (lbs.)	Dimensions (mm)														Rep. Latch Stock No.	
Carbon	Alloy				A	B	C	D	F	G	H	J	K	L	M	O †	R	S		AA**
.75	1.25	1048603	1048807	.34	51.0	20.8	31.8	72.5	31.8	18.5	20.6	23.6	16.0	144	16.0	23.6	116	9.65	38.1	1096325
1	1.60	1048612	1048816	.57	63.5	33.3	38.1	80.0	35.1	21.3	23.9	24.6	18.0	170	18.0	24.6	136	12.7	50.8	1096374
1.6	2.50	1048621	1048825	1.02	76.0	38.1	44.5	91.0	38.1	25.4	29.5	26.9	22.4	197	22.4	26.9	155	16.0	50.8	1096421
2	3.20	1048630	1048834	1.04	76.0	38.1	44.5	102	41.1	28.7	33.3	30.2	23.9	210	23.9	29.5	165	16.0	50.8	1096468
3.2	5.4	1048639	1048840	2.25	89.0	41.7	50.8	123	51.0	36.6	41.4	38.1	33.3	246	28.7	35.8	191	19.1	63.5	1096515
5	8.0	1048648	1048859	4.67	116	58.0	63.5	160	63.5	46.0	52.5	45.2	42.2	317	36.6	42.9	245	25.4	76.2	1096562
7.5	11.5	1048657	1048868	8.80	127	62.0	70.0	192	76.0	57.0	67.0	51.0	47.8	375	41.4	56.5	289	28.7	101	1096609
10	16	1048666	1048880	10.5	143	63.0	79.0	212	82.5	66.0	74.5	66.5	55.5	417	49.3	61.0	311	31.8	101	1096657
15	22	1048675	1048889	21.3	180	95.5	104	263	108	76.0	89.0	86.5	68.5	542	60.5	81.0	424	38.1	127	1096704
-	31.5	-	-	32.0	180	95.5	104	346	127	93.0	118	102	72.5	590	76.2	82.6	459	38.1	165	1093716

Carbon swivel hooks .75tC-15tC: proof load is 2 times working load limit. Designed with a 5 to 1 safety factor. Alloy swivel hooks 1.25tA-31.5tA : proof load is 2.5 times working load limit. Designed with a 4 to 1 safety factor. Alloy swivel hook 30tA: proof load is 2 times working load limit. Designed with a 4 to 1 design factor. \*\* Deformation Indicators. † Dimensions for hooks 3/4t carbon thru 22t alloy are for S-4320 latch kits. Dimensions for hooks 31.5 ton alloy are for PL latch kit.



# Crosby® Swivel Hooks



**S-3322B**  
Swivel Hooks  
with Bearing

**New anti-friction bearing design allows hook to rotate freely under load.**

- Capacities ranging from 2 through 15 metric tonnes.
- Forged - Quenched and Tempered.
- Proper design, careful forging, and precision controlled quench and tempering gives maximum strength without excessive weight and bulk.
- Low profile hook tip designed to utilize Crosby S-4320 or PL-N latch kit. Simply purchase the latch assemblies listed and shown on pages 121 - 122. Even years after purchase of the original hook, latch assemblies can be added.
- S-3322 hooks incorporate markings forged into the product which address two (2) **QUIC-CHECK®** features:
  - **Deformation Indicators** — Two strategically placed marks, one just below the shank or eye and the other on the hook tip, which allows for a QUIC-CHECK® measurement to determine if the throat opening has changed, thus indicating abuse or overload
  - **Angle Indicators** — Indicates the maximum included angle which is allowed between two (2) sling legs in the hook. These indicators also provide the opportunity to approximate other included angles between two sling legs.

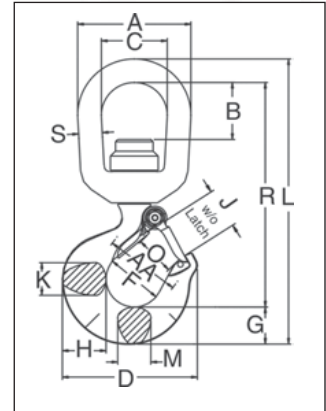

For other swivel hooks designed to rotate under load, see pages 121, 129, 130, 138-141. Use in corrosive environment requires shank and nut inspection in accordance with ASME B30.10-1.10.4 (b)(5)(c) 2009.

## S-3322B Swivel Hooks with Bearing

Working Load Limit (t)	S-3322B Stock No.	L-3322B Stock No.†	Weight Each (kg)	Dimensions (mm)																Rep. Latch Stock No.
				A	B	C	D	F	G	H	J	K	L	M	O	R	S	AA**		
2	1028605	1028609	1.13	76.2	38.1	44.5	91.2	38.1	25.4	29.5	26.9	22.4	194	22.4	25.4	152	16.0	50.8	1096421	
3	1028614	1028618	1.72	88.9	39.6	50.8	101	41.1	28.7	33.3	30.2	23.9	218	23.9	27.7	170	19.1	50.8	1096468	
5	1028623	1028627	3.17	101	39.6	57.2	122	50.8	36.6	41.4	38.1	33.3	262	28.7	34.5	203	22.4	63.5	1096515	
7	1028632	1028636	6.35	127	49.3	69.9	159	63.5	46.0	52.3	45.2	42.2	326	36.6	40.9	251	28.7	76.2	1096562	
11	1028641	1028645	10.1	142	52.1	79.2	191	76.2	57.2	66.8	61.2	47.8	387	41.4	52.8	298	31.8	101	1096609	
15	1028650	1028654	16.3	180	91.9	104	211	82.6	65.8	74.7	66.5	55.6	473	49.3	57.7	366	38.1	101	1096657	

\* Proofload is 2.5 times working load limit. Designed with a 4.5 to 1 design factor.

\*\* Deformation Indicators.

† Supplied with latch attached.



**S-1316**  
EYE HOOK

**All SHUR-LOC® hooks have the following features:**

- Forged Alloy Steel - Quenched and Tempered.
- Recessed trigger design is flush with the hook body, protecting the trigger from potential damage.
- Easy to operate with enlarged thumb access.
- Positive Lock Latch is Self-Locking when hook is loaded.
- The SHUR-LOC® hook, if properly installed and locked, can be used for personnel lifting applications and meets the intent of OSHA Rule 1926.1431(g)(1)(i)(A) and 1926.1501(g)(4)(iv)(B).



**S-1318A**  
SHANK HOOK

**Eye Style incorporates these added features:**

- Individually Proof Tested to 2-1/2 times the 4:1 Working Load Limit with certification.
- S-1316 meets the performance requirements of EN1677-3:2001
- 25% stronger than Grade 80.
- Suitable for use with Grade 100 and Grade 80 chain.
- Designed with "Engineered Flat" to connect to S-1325 chain coupler.

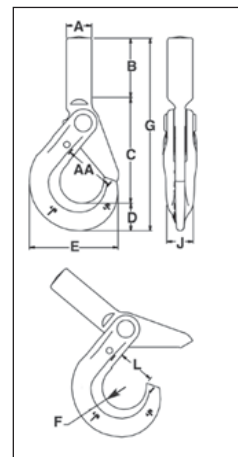
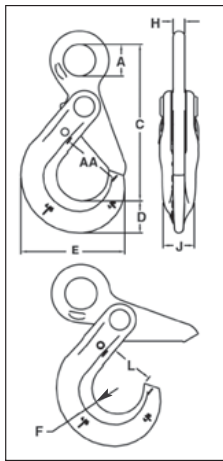

**S-1316 Eye Hook • SHUR-LOC® Hook Series with Positive Locking Latch**

Chain Size		Working Load Limit (t)*	Wire Rope XXIP IWRC Mechanical Splice		S-1316 Stock No.	Weight Each (kg)	Dimensions (mm)									
(in.)	(mm)		Size (mm)	Working Load Limit (t) 5:1			A	C	D	E	F	H	J	L	AA**	
-	6	1.45	8	1.00	1022896	.39	19.8	100	20.1	66.0	17.0	7.87	16.0	29.5	38.1	
1/4-5/16	7-8	2.60	11	1.90	1022914	.82	27.4	135	27.9	88.9	22.1	9.91	20.6	37.6	51.0	
3/8	10	4.00	13	2.50	1022923	1.54	33.0	167	29.7	112	27.9	12.9	23.9	46.5	63.5	
1/2	13	6.80	19	5.62	1022932	2.72	41.9	209	42.4	139	32.0	17.0	29.5	56.4	76.2	
5/8	16	10.30	22	7.53	1022941	6.83	55.9	256	51.8	167	38.1	22.1	38.1	67.3	89.0	
3/4	18-20	16.00	25	9.98	1022942	8.61	66.0	274	56.4	197	51.1	22.1	51.6	89.4	-	
7/8	22	19.40	28.6	12.0	1022943	12.7	72.9	317	62.2	222	57.7	24.9	55.9	97.3	-	
1	26	27.10	-	-	1022944	22.45	80.0	371	81.5	251	62.5	32.0	68.1	104	-	

\* Minimum Ultimate Load is 4 times the Working Load Limit. \*\* Deformation Indicators.

**S-1318A SHUR-LOC® Shank Hook**

Chain Size		S-1318A Stock No.	Frame code	Grade 100 Alloy Chain Working Load Limit (t)*	Dimensions (mm)										Weight Each (kg)
(in.)	(mm)				A†	B	C	D	E	F	G	J	L	AA**	
-	6	1098200	D	1.45	20.1	55.0	84.0	20.1	66.0	17.0	159	16.0	28.7	38.1	.45
1/4-5/16	7-8	1098209	G	2.59	25.4	61.0	106	27.9	89.0	22.1	195	20.6	35.1	51.0	.90
3/8	10	1098218	H	3.99	29.0	75.0	131	29.7	112	27.9	235	23.9	46.5	63.5	1.61
1/2	13	1098227	I	7	34.0	85.0	160	42.4	138	32.0	288	29.5	53.5	76.2	3.18

\* Ultimate Load is 4 times the Working Load Limit based on Grade 100 chain. \*\* Deformation Indicators. † Dimension before machining (as forged).



# Crosby® SHUR-LOC® Hooks



**S-1326  
SWIVEL HOOK**

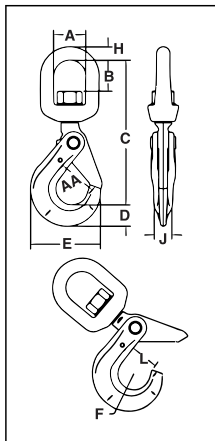

- Forged Alloy Steel - Quenched and Tempered.
- Individually Proof Tested at 2-1/2 times the 4:1 Working Load Limit with certification.
- Recessed trigger design is flush with the hook body, protecting the trigger from potential damage.
  - Easy to operate with enlarged thumb access.
- Positive Lock Latch is Self-Locking when hook is loaded.
- Rated for both Wire Rope and use with Grade 80/100 Chain.
- G-414 Heavy Thimble should be used with wire rope slings.
- Trigger Repair Kit available (S-4316). Consists of spring, roll pin and trigger.
- S-13326 Swivel Hook utilizes anti-friction bearing design which allows hook to rotate freely under load.
- Fatigue rated.
- The SHUR-LOC® hook, if properly installed and locked, can be used for personnel lifting applications and meets the intent of OSHA Rule 1926.1431(g)(1)(i)(A) and 1926.1501(g)(4)(iv)(B).
- "Look for the Platinum Color – Crosby Grade 100 Alloy Products."



**S-13326  
SWIVEL HOOK  
with BEARING**

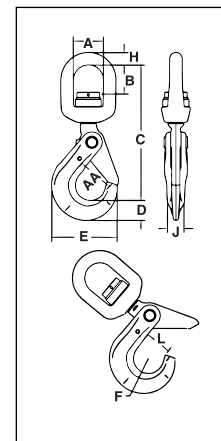

**SEE APPLICATION AND WARNING INFORMATION**  
On Pages 272 - 273  
Para Español: [www.thecrosbygroup.com](http://www.thecrosbygroup.com)

**Crosby 8/10™**



**Fatigue Rated™**



*Use in corrosive environment requires shank and nut inspection in accordance with ASME B 30.10-1.10.4 (b)(5)(c) 2009. The S-1326 hook is a positioning device and is not intended to rotate under load. For swivel hook designed to rotate under load, use the S-13326.*

## S-1326 SHUR-LOC® Swivel Hooks • Suitable for infrequent, non-continuous rotation under load.

Chain Size		Grade 100 Alloy Chain Working Load Limit (t) 4:1*	Wire Rope XXIP IWRC Mechanical Splice Working Load Limit (t) 5:1*	S-1326 Stock No.	Weight Each (kg)	Dimensions (mm)										
						A	B	C	D	E	F	H	J	L	AA**	
-	6	1.45	1.16	1004304	.57	38.1	33.5	156	20.1	66.0	17.0	12.7	16.0	28.7	38.1	
1/4 - 5/16	7-8	2.59	2.1	1004313	1.18	44.5	40.4	193	27.9	88.9	22.1	16.0	20.6	35.1	51.0	
3/8	10	3.99	3.2	1004322	2.13	50.8	43.9	224	29.7	112	27.9	19.1	23.9	44.5	63.5	
1/2	13	6.80	5.4	1004331	3.92	63.5	60.5	284	42.4	139	32.0	25.4	29.5	53.6	76.2	
5/8	16	10.3	8.2	1004340	7.71	69.9	64.3	328	51.8	167	38.1	28.7	38.1	63.2	89.0	
3/4	18 - 20	16.0	12.8	1004349	10.9	71.9	64.0	358	56.4	197	51.1	27.9	51.6	89.4	127	
7/8	22	20.0	16.0	1004358	13.2	87.4	81.0	417	62.2	222	57.4	33.0	55.9	97.3	152	

\*Ultimate Load is 4 times the Working Load Limit. \*\* Deformation Indicators.

## S-13326 SHUR-LOC® Swivel Hooks with Bearing • Suitable for frequent rotation under load.

Chain Size		Grade 100 Alloy Chain Working Load Limit (t) 4:1*	Wire Rope XXIP IWRC Mechanical Splice Working Load Limit (t) 5:1*	S-13326 Stock No.	Weight Each (kg)	Dimensions (mm)										
						A	B	C	D	E	F	H	J	L	AA**	
-	6	1.45	1.16	1004404	.57	38.1	29.0	157	20.1	66.0	17.0	12.7	16.0	28.7	38.1	
1/4 - 5/16	7-8	2.59	2.1	1004413	1.18	44.5	38.6	192	27.9	89.0	22.1	16.0	20.6	35.1	51.0	
3/8	10	3.99	3.2	1004422	2.13	51.0	40.9	226	29.7	112	27.9	19.1	23.9	46.5	63.5	
1/2	13	6.80	5.4	1004431	3.92	63.5	51.6	282	42.4	138	32.0	25.4	29.5	53.5	76.2	
5/8	16	10.3	8.2	1004440	7.71	70.0	50.3	328	52.0	167	38.1	28.7	38.1	63.0	89.0	

\* Ultimate Load is 4 times the Working Load Limit. \*\* Deformation Indicators.



**BH-313  
Weld-On  
Hook**

- Wide range of sizes available: 1-10 metric ton capacity.
- Forged Alloy Steel.
- Designed for attachment to mobile lifting equipment to provide a pick point for easy sling attachment.
- Large weld pad.
- Heavy duty latch interlocks with the hook tip. Replacement latches available.
- Detailed installation and application instructions included with each hook.

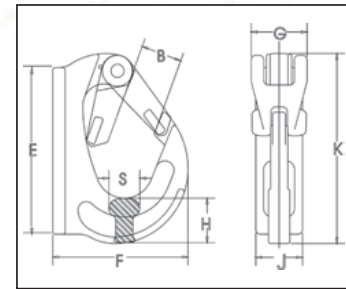

**SEE APPLICATION AND WARNING INFORMATION**  
On Pages 148 - 149  
Para Español: [www.thecrosbygroup.com](http://www.thecrosbygroup.com)

**BH-313 Weld-On Hooks**

Working Load Limit (t)*	BH-313 Stock No.	Weight Each (kg)	Dimensions (mm)								Replacement Latch Stock No.
			B	E	F	G	H	J	K	S	
1	1029105	.52	23.1	97.0	71.0	36.1	26.9	25.9	107	18.0	1092104
2	1029114	.84	23.1	82.0	91.0	36.1	24.9	34.0	115	21.1	1092104
3	1029123	1.18	29.0	117	105	36.1	31.0	36.1	131	23.9	1092104
4	1029132	1.90	34.0	131	114	46.0	36.1	42.9	147	29.0	1092105
5	1029141	2.55	34.0	161	133	47.0	45.0	43.9	173	29.0	1092105
8	1029150	3.30	35.1	166	135	47.0	52.0	52.0	178	39.1	1092105
10	1029169	5.00	49.0	205	168	47.0	57.0	54.0	222	39.1	1092106

\*Ultimate Load is 5 times the Working Load Limit.



**S-3319  
Utility Swivel  
Hook**

- Capacities of 1.63, 2.50 and 4.50 metric tons
- Synthetic Rope sizes: 14mm - 27mm
- Hook is forged Alloy Steel - Quenched and Tempered.
- Can be proof tested to 2 times the Working Load Limit.
- Designed for utility applications using synthetic rope.
- Design of hook provides needed overhaul weight.
- Utilizes spool & shield designed to:
  - Protect rope
  - Keep rope positioned correctly on spool.
  - Provide wider rope bearing surface resulting in an increased area for load distribution and reduces rope abrasion.
- Low profile hook tip designed to utilize Crosby integrated latch (S-4320), that meets the world-class standard for lifting.

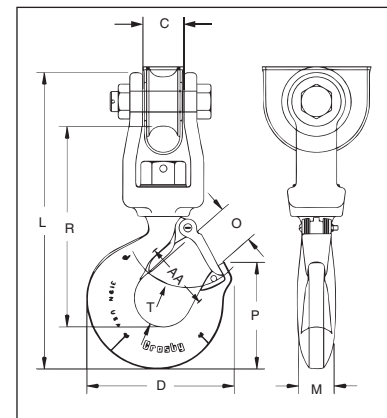

*Suitable for infrequent, non-continuous rotation under load. Use in corrosive environment requires shank and nut inspection in accordance with ASME B30.10-1.10.4(b)(5)(c)2009.*



**SEE APPLICATION AND WARNING INFORMATION**  
On Pages 142 - 143  
Para Español: [www.thecrosbygroup.com](http://www.thecrosbygroup.com)

**S-3319 Utility Swivel Hook**

Working Load Limit (t)*	S-3319 Stock No.	Weight Each (kg)	Hook ID Code	Synthetic Rope Size (mm)	Dimensions (mm)								Replacement Latch Kit Stock No.	
					C	D	L	M	O	P	R	T		AA**
1.63	1002054	1.90	H	14 - 16	27.7	101	222	23.9	29.5	70.6	151	29.5	2.00	1096468
2.50	1002063	3.62	I	19 - 21	33.2	123	268	30.2	35.8	88.1	179	38.9	2.50	1096515
4.50	1002072	6.80	J	22 - 27	45.2	160	324	36.6	45.2	117	221	49.3	3.00	1096562

\*Ultimate Load is 5 times the Working Load Limit. \*\* Deformation Indicators.



# Crosby® Hook Latch Kits



**S-4320  
Latch Kits**

- Heavy duty stamped latch interlocks with the hook tip.
- High cycle, long life spring.
- Can be made into a “Positive Locking” Hook when proper cotter pin is utilized.
- Latch kits shipped unassembled and individually packaged with instructions.
- Meets the intent of OSHA Rule 1926.1431(g) and 1926.1501(g) (when secured with the bolt, nut and pin) for lifting personnel.

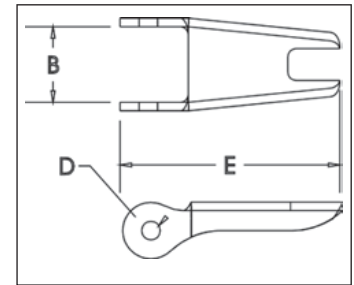

**IMPORTANT:** The new S-4320 Latch Kit will not fit the old style 319, 320 and 322 hooks.



## S-4320 Replacement Latch Kit for 319N, 320N, 322N, 339N, 1327 and 1339 Hooks

Hook Size (t)			Hook ID Code	S-4320 Stock No.	SS-4320 Stock No.*	Weight Each (kg)	Dimensions (mm)		
Carbon	Alloy	Bronze					B	D	E
.75	1.25	.5	D	1096325	1097100	.01	12.7	3.80	36.6
1	1.6	.6	F	1096374	1097109	.02	13.7	4.30	39.6
1.6	2	1	G	1096421	1097118	.02	16.0	4.30	42.2
2	3.2	1.4	H	1096468	1097127	.03	16.8	4.30	48.5
3.2	5.4	2	I	1096515	1097136	.05	21.1	5.10	58.5
5	8	3.5	J	1096562	1097145	.07	26.4	5.10	73.2
7.5	11.5	5	K	1096609	1097154	.13	31.8	6.85	90.5
10	16	6.5	L	1096657	1097163	.15	34.3	6.85	97.0
15	22	10	N	1096704	1097172	.38	42.2	9.90	132

\*SS-4320 is Stainless Steel construction with cad plated steel nuts.

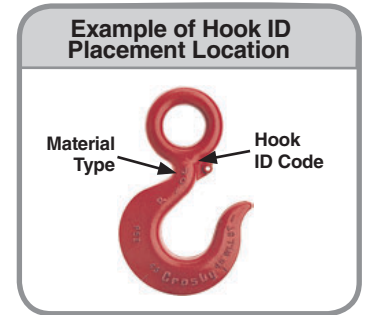

## IMPORTANT: Instructions for Assembling S-4320 Latch on Crosby 320N Hooks



**Step 1**

1. Place hook at approximately a 45 degree angle with the cam up.

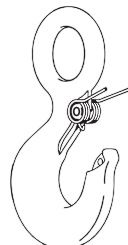

**Step 2**

2. Position coils of spring over cam with legs of spring pointing toward point of hook and loop of spring positioned down and lying against the hook.



**Step 3**

3. Position latch to side of hook points. Slide latch onto spring legs between lockplate and latch body until latch is partially over hook cam. Then depress latch and spring until latch clears point of hook.

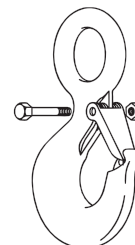

**Steps 4, 5, & 6**

4. Line up holes in latch with hook cam.  
5. Insert bolt through latch, spring, and cam.  
6. Tighten self-locking nut on one end of bolt.

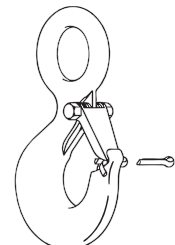

**Step 7**

**(For Personnel Lifting)**

7. With latch in closed position and rigging resting in bowl of hook, insert cotter pin through hook tip and secure by bending prongs.

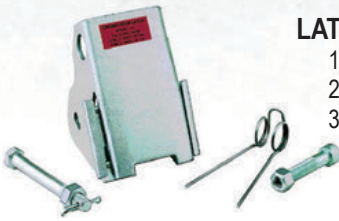

PL Latch Kits

**LATCH ORDERING INSTRUCTIONS**

1. Specify PL, PL-N or PL-O latch kit stock number from charts below.
2. Specify capacity of hook to which latch will be assembled.
3. Specify hook material (carbon or alloy).



The PL latch will not work on 319N, 320N or 322N hooks. The PL-N/O latches, in the sizes available, will work on both the old and new style hooks.

- Hot dip galvanized.
- Heavy duty latch with easy operating features.
- Flapper lever indicates locked or unlocked position.
- Assembly instructions included with each latch.
- For additional dimensional data on eye, shank or swivel hooks refer to pages 110 through 115 in this section.
- Meets the intent of OSHA Rule 1926.1431(g) and 1926.1501(g) (when secured with the bolt, nut and pin) for lifting personnel.

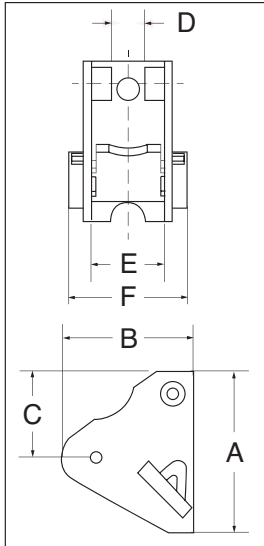

**PL LATCH KITS**

Hook Size (t)		Hook ID Code	PL Latch Kit Stock No.	Weight Each (kg)	Dimensions (mm)					
Carbon	Alloy				A	B	C	D	E	F
3.2	5.4	†I	1093711	.24	65.5	59.5	49.3	14.2	28.7	51.0
5	8	†J	1093712	.30	76.0	59.5	51.0	16.0	35.1	56.5
7.5	11.5	†K	1093713	.45	92.0	70.5	60.5	16.0	41.4	60.5
10	16	†L	1093714	.57	102	82.0	68.5	16.0	47.8	86.0
15	22	†N	1093715	1.34	135	102	74.0	21.3	60.5	87.5
20	31.5	O	1093716	1.84	152	113	81.0	26.9	73.0	108
25	37	P	1093717	3.91	178	168	103	57.0	114	155
30	45	S	1093718	4.54	171	178	102	57.0	121	162
40	60	T	1093719	6.49	203	195	111	88.0	140	184
50	75	U	1093720	12.2	251	208	130	86.0	165	226
-	100-150	W - X	1093721	15.1	276	281	162	86.0	191	254
-	200	Y	1093723	20.4	302	284	162	86.0	222	286
-	300	Z	1093724	24.9	318	310	203	86.0	248	330

†New 319N style hook.



PL-N/O Latch Kits

**LATCH ORDERING INSTRUCTIONS**

1. Specify PL, PL-N or PL-O latch kit stock number from charts below.
2. Specify capacity of hook to which latch will be assembled.
3. Specify hook material (carbon or alloy).



- Heavy duty latch with easy operating features.
- PL-N designed for Crosby 319N & 320N style hooks, PL-O designed for Crosby 319 & 320 old style hooks.
- Flapper lever indicates locked or unlocked position.
- Assembly instructions included with each latch.
- For additional dimensional data on eye, shank or swivel hooks refer to pages 114 through 122 in this section.
- Meets the intent of OSHA Rule 1926.1431(g) and 1926.1501(g) (when secured with the supplied toggle pin) for lifting personnel

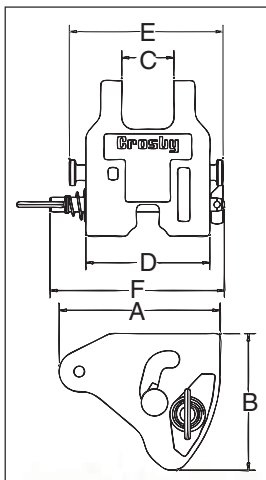

**PL-N/O LATCH KITS**

Hook Size (t)		Hook ID Code	PL-N Latch Kit	PL-O Stock No.	Weight Each (kg)	Dimensions (mm)					
Carbon	Alloy					A	B	C	D	E	F
3.2	5.4	I	1092000	1091900	.36	60.9	51.0	21.1	54.1	68.8	87.4
5	8	J	1092001	1091901	.58	74.7	63.5	25.4	64.0	81.0	97.3
7.5	11.5	K	1092002	1091902	.90	92.2	76.7	30.2	69.9	87.4	111
10	16	L	1092003	1091903	1.27	102	86.1	34.0	81.0	102	114
15	22	N	1092004	1091904	2.22	132	110	40.9	98.0	122	130

\*\*N" style hooks are rated at 5 tonnes.





**SS-4055  
Latch Kits**

## LATCH ORDERING INSTRUCTIONS

1. Specify latch kit stock number.
2. Specify capacity of hook to which latch will be assembled.
3. Specify hook material (carbon or alloy).



These latches will not work on new "N" style hooks.

- Stainless steel construction with cadmium plated steel nuts.
- Shipped packaged and unassembled.
- Instructions included for easy field assembly.



## SS-4055 LATCH KITS

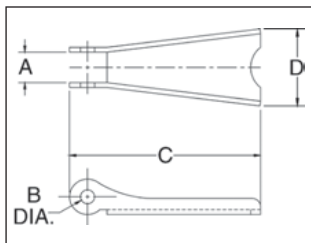

Hook Size (t)			Hook ID Code	SS-4055 Stock No.	Weight Each (kg)	Dimensions (mm)			
Carbon	Alloy	Bronze				A	B	C	D
.75	1.25	.5	D	1093426	.01	9.65	4.05	36.6	15.0
1	1.6	.6	F	1093444	.01	9.65	4.05	40.6	15.0
1.6 - 2.0	2.5 - 3.2	1.0 - 1.4	G / H	1093462	.01	11.9	4.85	46.7	20.8
3.2	5.4	2.0	I	1093480	.05	14.2	4.30	61.0	25.4
5	8	3.5	J	1093505	.05	14.7	5.10	75.5	30.7
7.5 - 10	11.5 - 16	5.0 - 6.5	K / L	1090125	.08	15.0	6.86	93.0	38.1
15	22	10.0	N	1090143	.18	21.1	9.90	125	48.3
20	30	--	O	1090161	.29	23.9	13.2	149	65.0
25 - 30	37 - 45	--	P / S	1090189	.51	55.5	9.90	165	97.5
40	60	--	T	1090205	.80	84.0	13.2	200	105



**S-4088  
Alloy Hook  
Latch Kits**

## LATCH ORDERING INSTRUCTIONS

1. Specify latch kit stock number.
2. Specify capacity of hook to which latch will be assembled.
3. Specify hook material (carbon or alloy).

- To be used on A-327 and A-339 Grade 8 Sling Hooks.
- Latch Kits shipped unassembled and individually packaged with instructions.

## S-4088 LATCH KITS

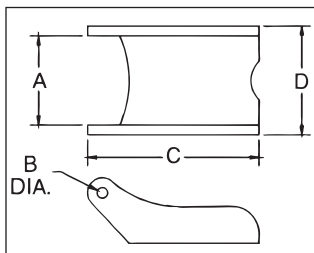

Hook Chain (mm)	S-4088 Stock No.	Weight Each (kg)	Dimensions (mm)			
			A	B	C	D
6-7	1090250	.03	19.8	4.05	51.5	23.9
8-10	1090251	.06	26.2	4.85	68.5	31.8
13	1090252	.07	26.2	4.85	76.0	31.8
16	1090253	.07	26.2	4.85	82.5	31.8
19	1090254	.07	38.9	6.60	105	47.8
22	1090255	.07	38.9	6.60	118	51.0

# Crosby®/ Bullard® Golden Gate® Hooks

## HOOK CONNECTORS

The 6 connector styles shown below make it possible for Crosby to furnish a Golden Gate Hook to fit almost any make or model of hoisting equipment including American Engineering Lo-Hed, ARO, Coffing, Electro Lift, Ingersoll-Rand, P & H, Robbins and Myers, Shepard Niles, CM, Shaw-Box, Wright, Yale & Towne.

### CLOSED SWIVEL BAIL

For use where hoisting line or shackle can be inserted into the bail. Suitable for infrequent, non continuous rotation under load. Hook sizes: 1 through 14.

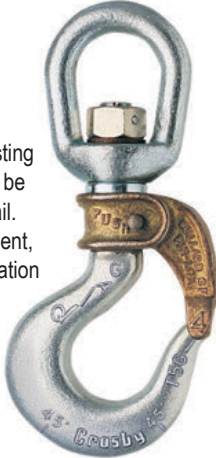

**Style C** — with self-closing gate.  
**Style A** — with manual-closing gate.

### SHANK-TYPE HOOK

(Standard Length)

For use on existing load blocks, with standard shank length. Hook sizes: 2 through 14.

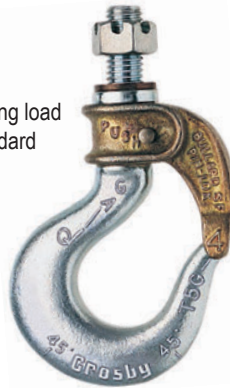

**Style D** — with self-closing gate.  
**Style B** — with manual-closing gate.

### SHANK-TYPE HOOK

(Long Length)

For use on existing load blocks requiring extra shank length. Hook sizes: 4 through 17.



**Style K** — with self-closing gate.  
**Style I** — with manual-closing gate.

### UNIVERSAL TYPE

Open swivel bail for attachment to link chain. Suitable for infrequent, non continuous rotation under load. Hook sizes: 3, 4 and 5.

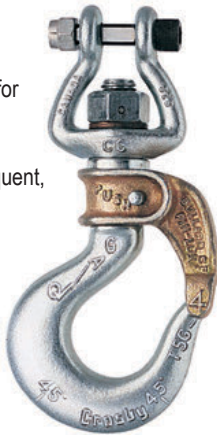

**Style E** — with self-closing gate.  
**Style G** — with manual-closing gate.

### LINK CHAIN NEST

With ball-bearing swivel; attaches to chain by an alloy pin. Suitable for frequent rotation under load. Hook sizes: 4, 5 and 7.



**Style O** — with self-closing gate.  
**Style P** — with manual-closing gate.

### ROLLER CHAIN NEST

Attachment with ball-bearing swivel and full-floating connector. Suitable for frequent rotation under load. Hook sizes: 4, 5 and 6.



**Style S** — with self-closing gate.  
**Style R** — with manual-closing gate.

Letter designations shown beneath each illustration above indicate BOTH connector style and gate type. Each connector is available with either a self-closing or manual-closing gate. (e.g.: A size 4 hook with a closed swivel bail connector and self-closing gate is 4-C; with manual-closing gate, it is 4-A.)





## GATE TYPES

The 6 connector styles shown below make it possible for Crosby to furnish a Golden Gate Hook to fit almost any make or model of hoisting equipment including American Engineering Lo-Hed, ARO, Coffing, Electro Lift, Ingersoll-Rand, P & H, Robbins and Myers, Shepard Niles, CM, Shaw-Box, Wright, Yale & Towne.

**LIF-LOK® GATE - SIZE 1**



**To Lock:** Close the gate; the built-in spring locks the gate against the hook tip.  
**To Unlock:** Lift the gate upward on the hook shank and swing open.

**ROLLOX® GATE - SIZE 5 through 9**



**To Lock:** Close the gate; a stainless steel pin is mounted in a horizontal bore which passes through the gate and engages a notch milled in the hook shank.  
**To Unlock:** Move the lever downward a quarter-turn or until it stops, the gate can now swing open 160° (approx.)

**PIN-LOK® GATE - SIZE 2 through 4**



**To Lock:** Close the gate; a stainless steel pin is carried in a horizontal bore and engages a milled slot in the hook shank.  
**To Unlock:** Simply depress the stainless steel pin which causes the pin to disengage from the milled slot.

**TIP-LOK® GATE - SIZE 10 through 17**



**To Lock:** Press the arm down until the lock trips; two arms of the gate now enclose the tip of the hook.  
**To Unlock:** Manually depressing the locking trigger automatically raises the movable arm, allowing the gate to be rotated open.

# Crosby® / Bullard® Golden Gate® Hooks



Closed Swivel Bail

- For use where hoisting line or shackle can be inserted into the bail.
  - **BL-C** - with self-closing gate.
  - **BL-A** - with manual-closing gate.
- Suitable for infrequent, non-continuous rotation under load.
- Use in corrosive environment requires shank and nut inspection in accordance with ASME B30.10-1.10.4(b)(5)(c)2009.
- Crosby®/Bullard® Hooks incorporate two types of strategically placed markings forged into the product which address two (2) **QUIC-CHECK®** features:
  - Angle Indicators and Deformation Indicators (see the Bullard® **QUIC-CHECK®** table at bottom of page 129 for detailed definition).

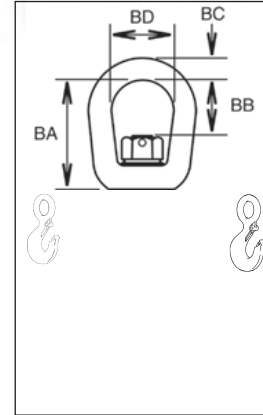

## Closed Swivel Bail

Hook Size	BL-C Stock No.	BL-A Stock No.	Gate Type	Working Load Limit (t)*	Weight Each (kg)	Dimensions (mm)													
						A	B	C	D	E	F	G	H	I	J	BA	BB	BC	BD
1	1050210	1050001	LIF-LOK	.45	.36	82.0	58.7	16.0	6.60	17.5	22.4	57.0	17.5	16.0	11.2	44.5	16.0	7.85	25.4
2	1050221	1050012	PIN-LOK	.90	.59	105	76.2	23.6	4.06	24.6	31.8	73.0	20.6	19.1	11.2	47.2	24.1	9.65	31.8
3	1050232	1050023	PIN-LOK	1.3	.86	114	84.0	23.9	5.58	26.9	35.1	84.0	23.9	21.3	16.0	62.0	33.3	12.7	38.1
4	1050243	1050034	PIN-LOK	1.5	1.00	124	92.2	25.4	5.58	28.7	38.1	92.0	29.5	25.4	19.1	67.5	34.3	12.7	38.1
5	1050254	1050045	ROLLOX	2.1	1.72	143	105	31.2	6.35	31.8	41.7	104	33.3	28.4	21.3	74.0	40.6	16.0	44.5
6	1050265	1050056	ROLLOX	3.6	2.09	158	119	31.8	6.35	35.3	41.7	116	39.9	34.0	24.6	78.5	35.8	16.0	44.5
7	1050276	1050067	ROLLOX	3.8	3.13	168	132	28.4	6.35	38.1	51.0	125	41.4	36.6	28.7	88.5	42.4	19.1	51.0
8	1050287	1050078	ROLLOX	5.0	4.35	182	147	26.9	7.11	44.5	57.0	148	51.0	41.9	31.2	103	51.0	22.4	57.0
9	1050298	1050089	ROLLOX	6.5	6.12	199	164	26.9	7.87	47.8	63.5	165	52.5	46.0	35.1	118	56.0	26.2	63.5
11	1050309	1050100	TIP-LOK	8.3	9.30	244	203	31.8	7.87	57.0	76.0	192	67.0	57.0	41.1	124	66.5	28.7	70.0
12	1050320	1050111	TIP-LOK	11.1	12.3	267	225	31.8	9.65	63.5	82.5	221	74.5	65.5	49.3	130	57.0	31.8	79.5
14	1050342	1050133	TIP-LOK	16.7	25.0	320	273	35.8	9.65	86.0	108	279	89.0	75.5	60.5	203	108	41.4	104

\*Ultimate Load is 4 times the Working Load Limit.



Open Swivel Bail

- Open Swivel Bail for attachment to link chain.
  - **BL-E** - with Self-Closing Gate
  - **BL-G** - with Manual-Closing Gate
- Suitable for infrequent, non-continuous rotation under load.
- Use in corrosive environment requires shank and nut inspection in accordance with ASME B30.10-1.10.4(b)(5)(c)2009.
- Crosby®/Bullard® Hooks incorporate two types of strategically placed markings forged into the product which address two (2) **QUIC-CHECK®** features:
  - Angle Indicators and Deformation Indicators (see the Bullard® **QUIC-CHECK®** table at bottom of page 129 for detailed definition).

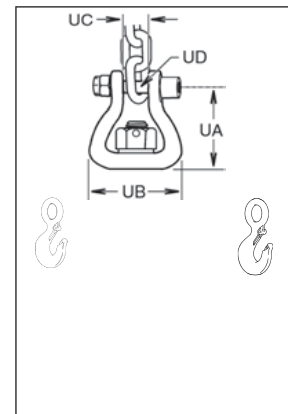

## Open Swivel Bail

Hook Size	BL-E Stock No.	BL-G Stock No.	Gate Type	Working Load Limit (t)*	Weight Each (kg)	Dimensions (mm)													
						A	B	C	D	E	F	G	H	I	J	UA	UB	UC	UD
3	1051607	1051706	PIN-LOK	1.3	.81	114	84.5	23.9	5.58	26.9	35.1	81.0	23.9	21.3	16.0	53.0	59.0	13.2	9.65
4	1051618	1051717	PIN-LOK	1.5	.95	124	92.2	25.4	5.58	28.7	38.1	92.0	29.5	25.4	19.1	54.5	59.0	13.2	9.65
5	1051629	1051728	ROLLOX	2.1	1.45	143	105	31.2	6.35	31.8	41.7	104	33.3	28.4	21.3	65.0	67.0	15.7	11.2

\*Ultimate Load is 4 times the Working Load Limit.



# Crosby®/Bullard® Golden Gate® Hooks



Link Chain Nest

- With ball bearing swivel; attaches to chain by an alloy pin.
  - **BL-O** - with Self-Closing Gate
  - **BL-P** - with Manual Closing Gate
- Suitable for frequent rotation under load.
- Use in corrosive environment requires shank and nut inspection in accordance with ASME B30.10-1.10.4(b)(5)(c)2009.
- Crosby®/Bullard® Hooks incorporate two types of strategically placed markings forged into the product which address two (2) **QUIC-CHECK®** features:
  - Angle Indicators and Deformation Indicators (see the Bullard® **QUIC-CHECK®** table at bottom of page 129 for detailed definition).

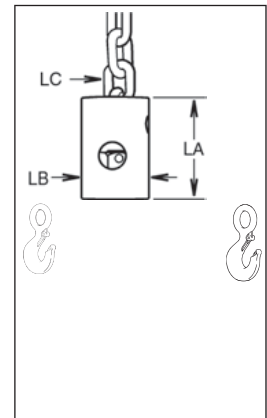

## Link Chain Nest

Hook Size	BL-O Stock No.	BL-P Stock No.	Gate Type	Working Load Limit (t)*	Weight Each (kg)	Dimensions (mm)												
						A	B	C	D	E	F	G	H	I	J	LA	LB	LC
4:1/4-9/32	1051409	1051508	PIN-LOK	1.5	1.13	124	92.2	25.4	5.58	28.7	38.1	92.0	29.5	25.4	19.1	67.0	44.5	6.35-7.15
5:5/16-3/8	1051442	1051541	ROLLOX	2.1	2.04	143	105	31.2	6.35	31.8	41.7	104	33.3	28.4	21.3	76.0	57.0	7.95-9.50
7:3/8-7/16	1051464	1051563	ROLLOX	3.8	5.0	168	132	28.4	6.35	38.1	51.0	125	41.4	36.6	28.7	111	76.0	9.50-11.1
7:1/2-9/16	1051486	1051585	ROLLOX	3.8	5.0	168	132	28.4	6.35	38.1	51.0	125	41.4	36.6	28.7	111	76.0	12.7-14.3

\*Ultimate Load is 4 times the Working Load Limit.



Roller Chain Nest

- Attachment with ball-bearing swivel and full-floating connector.
  - **BL-S** - with Self-Closing Gate
  - **BL-R** - with Manual Closing Gate
- Suitable for frequent rotation under load.
- Use in corrosive environment requires shank and nut inspection in accordance with ASME B30.10-1.10.4(b)(5)(c)2009.
- Crosby®/Bullard® Hooks incorporate two types of strategically placed markings forged into the product which address two (2) **QUIC-CHECK®** features:
  - Angle Indicators and Deformation Indicators (see the Bullard® **QUIC-CHECK®** table at bottom of page 129 for detailed definition).

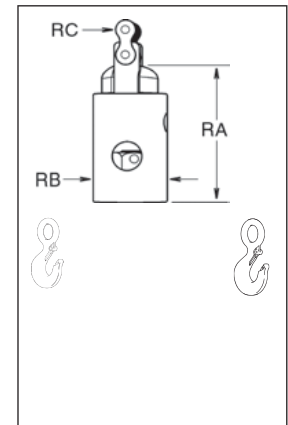

## Roller Chain Nest

Hook Size	BL-S Stock No.	BL-R Stock No.	Gate Type	Working Load Limit (t)*	Weight Each (kg)	Dimensions (mm)												
						A	B	C	D	E	F	G	H	I	J	RA	RB	RC
4 :#50	1051310	1051200	PIN-LOK	.68	1.32	124	92.2	25.4	5.58	28.7	38.1	92.0	29.5	25.4	19.1	89.5	44.5	15.9
5 :#60	1051321	1051211	ROLLOX	1.13	2.36	143	105	31.2	6.35	31.8	41.7	104	33.3	28.4	21.3	108	54.0	19.1
6 :#60	1051332	1051222	ROLLOX	1.13	2.81	158	119	31.8	6.35	35.3	41.7	116	39.9	34.0	24.6	108	54.0	19.1

\*Ultimate Load is 4 times the Working Load Limit.



Standard Length  
Shank Hooks

- For use on existing load blocks, with standard shank length.
- No.'s 2 through 12 style hooks are threaded approximately 80% of shank length.
  - **BL-C** - with self-closing gate.
  - **BL-A** - with manual-closing gate.
- Use in corrosive environment requires shank and nut inspection in accordance with ASME B30.10-1.10.4(b)(5)(c)2009.
- Crosby®/Bullard® Hooks incorporate two types of strategically placed markings forged into the product which address two (2) **QUIC-CHECK®** features:
  - Angle Indicators and Deformation Indicators (see the Bullard® **QUIC-CHECK®** table at bottom of page 129 for detailed definition).

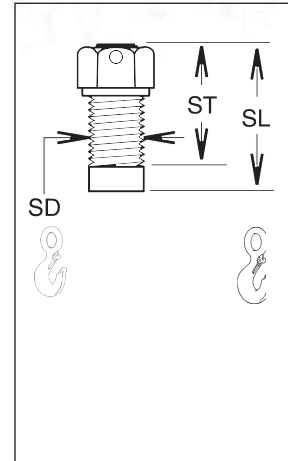

## Standard Length Shank Hooks

Hook Size	BL-D Stock No.	BL-B Stock No.	Gate Type	Working Load Limit (t)*	Weight Each (kg)	Dimensions (mm)												
						A	B	C	D	E	F	G	H	I	J	SD	SL	ST
2	1050606	1050408	PIN-LOK	.91	.50	105	76.2	23.6	4.06	24.6	31.8	73.0	20.6	19.1	14.2	12.7	23.1	15
3	1050617	1050419	PIN-LOK	1.3	.59	114	84.1	23.9	5.58	26.9	35.1	81.0	23.9	21.3	16.0	14.2	31.8	19.1
4	1050628	1050430	PIN-LOK	1.5	.77	124	92.2	25.4	5.58	28.7	38.1	92.0	29.5	25.4	19.1	16	33.3	30.2
5	1050639	1050441	ROLLOX	2.1	1.13	143	105	31.2	6.35	31.8	41.7	104	33.3	28.4	21.3	19.1	33.3	25.4
6	1050650	1050452	ROLLOX	3.6	1.59	158	119	31.8	6.35	35.3	41.7	116	39.9	34.0	24.6	22.4	43	29.5
7	1050661	1050463	ROLLOX	3.8	2.36	168	132	28.4	6.35	38.1	51.0	125	41.4	36.6	28.7	25.4	46	35.1
8	1050672	1050474	ROLLOX	5.0	3.22	182	147	26.9	7.11	44.5	57.0	148	51.0	41.9	31.2	28.7	52.5	38.1
9	1050683	1050485	ROLLOX	6.5	4.31	199	164	26.9	7.87	47.8	63.5	165	52.5	46.0	35.1	31.8	62	46
11 †	1050694	1050496	TIP-LOK	8.3	7.08	244	203	31.8	7.87	57.0	76.0	192	67.0	57.0	41.1	38.1	68.5	47.8
12 †	1050705	1050507	TIP-LOK	11.2	9.53	267	225	31.8	9.65	63.5	82.5	221	74.5	65.5	49.3	41.4	73	54
13	1050716	1050518	TIP-LOK	13.6	13.6	285	242	31.8	9.65	76.0	95.0	245	83.5	70.0	49.3	44.5	89	56
14	1050727	1050529	TIP-LOK	16.8	18.1	320	273	35.8	9.65	86.0	108	279	89.0	75.5	60.5	51	92.5	60.5

\*Ultimate Load is 4 times the Working Load Limit. If a drawing is not available, complete a Crosby/Bullard HOOK DATA FORM. Hook No.'s 2 through 12 style hooks are threaded approximately 80% of the shank length.



BL-PKU  
Double Ended Hook

- Makes Conductor Tensioning faster and easier.
- Suitable for frequent rotation under load.
- Use in corrosive environment requires shank and nut inspection in accordance with ASME B30.10-1.10.4(b)(5)(c)2009.
- Crosby®/Bullard® Hooks incorporate two types of strategically placed markings forged into the product which address two (2) **QUIC-CHECK®** features:
  - Angle Indicators and Deformation Indicators (see the Bullard® **QUIC-CHECK®** table at bottom of page 129 for detailed definition).

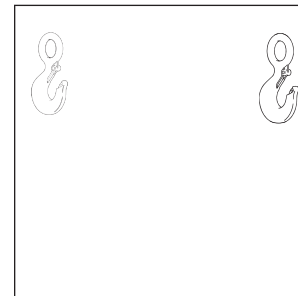

## Double Ended Hook (Available only with Manual Closing Gate.)

Hook Size and Type	BL-PKU Stock No.	Gate Type	Working Load Limit (t)*	Weight Each (kg)	Dimensions (mm)										
					A	B	C	D	E	F	G	H	I	J	
4PKU	1051805	PIN-LOK	1.5	2.27	124	92.2	25.4	5.58	28.7	38.1	92.0	29.5	25.4	19.1	
5PKU	1051816	ROLLOX	2.1	3.63	143	105	31.2	6.35	31.8	41.7	104	33.3	28.4	21.3	
6PKU	1051827	ROLLOX	3.6	5.00	158	119	31.8	6.35	35.3	41.7	116	39.9	34.0	24.6	

\*Ultimate Load is 4 times the Working Load Limit.



# Crosby® / Bullard® Golden Gate® Hooks



Long Length  
Shank Hooks

- For use on existing load blocks requiring extra shank length.
- No.'s 4 through 9 style hooks are threaded approximately 80% of shank length.
  - BL-K - with Self-Closing Gate
  - BL-I - with Manual Closing Gate
- Use in corrosive environment requires shank and nut inspection in accordance with ASME B30.10-1.10.4(b)(5)(c)2009.
- Crosby®/Bullard® Hooks incorporate two types of strategically placed markings forged into the product which address two (2) **QUIC-CHECK®** features:
  - Angle Indicators and Deformation Indicators (see the Bullard® **QUIC-CHECK®** table at bottom of page for detailed definition).

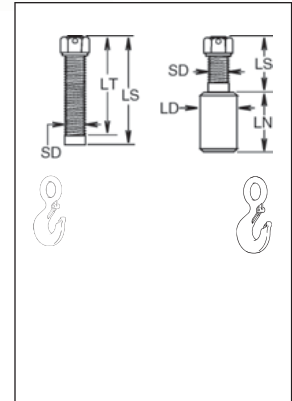

**SEE APPLICATION AND WARNING INFORMATION**  
On Pages 146 - 147  
Para Español: [www.thecrosbygroup.com](http://www.thecrosbygroup.com)

## Long Length Shank Hooks

Hook Size	BL-K Stock No.	BL-I Stock No.	Gate Type	Working Load Limit (t)*	Weight Each (kg)	Dimensions (mm)													
						A	B	C	D	E	F	G	H	I	J	SD	LN	LS	LT
4 :1/2	1051002	1050804	PIN-LOK	1.45	.86	124	92.2	25.4	5.58	28.7	38.1	92.0	29.5	25.4	19.1	12.7	11.2	81.0	81.0
4 :9/16	1051013	1050815	PIN-LOK	1.5	.86	124	92.2	25.4	5.58	28.7	38.1	92.0	29.5	25.4	19.1	14.2	12.2	81.0	81.0
4 :5/8	1051024	1050826	PIN-LOK	1.5	.86	124	92.2	25.4	5.58	28.7	38.1	92.0	29.5	25.4	19.1	16.0	14.0	84.0	81.0
5	1051035	1050837	ROLLOX	2.1	1.36	143	105	31.2	6.35	31.8	41.7	104	33.3	28.4	21.3	19.1	16.0	90.5	82.5
6	1051046	1050848	ROLLOX	3.6	1.72	158	119	31.8	6.35	35.3	41.7	116	39.9	34.0	24.6	22.4	19.1	103	90.0
7	1051057	1050859	ROLLOX	3.8	2.68	168	132	28.4	6.35	38.1	51.0	125	41.4	36.6	28.7	25.4	22.4	116	105
8	1051068	1050870	ROLLOX	5.0	3.54	182	147	26.9	7.11	44.5	57.0	148	51.0	41.9	31.2	28.4	23.9	129	114
9	1051079	1050881	ROLLOX	6.5	4.90	199	164	26.9	7.87	47.8	63.5	165	52.5	46.0	35.1	31.8	26.9	141	125
12 ‡	1051101	1050903	TIP-LOK	11.2	12.7	267	225	31.8	9.65	63.5	82.5	221	74.5	65.5	49.3	41.4	39.6	137	118
13 ‡	1051112	1050914	TIP-LOK	13.6	15.9	285	242	31.8	9.65	76.0	95.5	245	83.5	70.0	49.3	44.5	38.1	187	146
14 ‡	1051123	1050925	TIP-LOK	16.8	20.4	320	273	35.8	9.65	86.0	108	279	89.0	75.5	60.5	51.0	50.8	137	102
16	1051134	1050936	TIP-LOK	30.0	46.7	388	332	38.1	16.0	102	127	346	118	92.0	76.0	70.0	70.0	406	178
17	1051156	1050958	TIP-LOK	60.0	168	615	522	66.8	23.9	146	178	470	165	152	113	102	100	578	356

\*Ultimate Load is 4 times the Working Load Limit. If a drawing is not available, complete a Crosby/Bullard HOOK DATA FORM. Hook No.'s 4 through 9 are threaded approximately 80% of the shank length. ‡ Hook will have the shank extended by use of a Coupling Nut. Customer is required to complete and approve side 2 of a Crosby/Bullard HOOK DATA FORM. Hook No.'s 4 through 9 are threaded approximately 80% of the shank length.

## Crosby® / Bullard® Golden Gate Hooks Service Parts

Hook Size	Gate Type	BL-GA Gate Assemblies		BL-RK Gate Repair Kit Stock No.
		Manual Close Stock No.	Self Close Stock No.	
2	PIN-LOK	1100298	1100309	1100100
3	PIN-LOK	1100320	1100331	1100100
4	PIN-LOK	1100342	1100353	1100100
5	ROLLOX	1100364	1100375	1100111
6	ROLLOX	1100386	1100397	1100111
7	ROLLOX	1100408	1100419	1100122
8	ROLLOX	1100430	1100441	1100122
9	ROLLOX	1100452	1100463	1100122
10	TIP-LOK	1100474	1100485	1100133
11	TIP-LOK	1100496	1100507	1100144
12	TIP-LOK	1100518	1100529	1100155
13	TIP-LOK	1100540	1100551	1100166
14	TIP-LOK	1100562	1100573	1100177
15	TIP-LOK	1100584	1100595	1100188
16	TIP-LOK	1100606	1100617	1100199
17	TIP-LOK	1100639	1100628	1100210

## Quic-Check Deformation Indicator

Hook Size	Hook ID Code	AA (mm)
1	1	38.1
2	D	38.1
3	F	38.1
4	G	50.8
5	H	50.8
6	6	63.5
7	I	63.5
8	8	76.2
9	J	101.6
11	K	101.6
12	L	101.6
13	13	127.0
14	N	127.0
16	O	165.1
17	T	254.0



L-320R  
ROV Eye Hook

- Hook identification code stamped on each hook.
- Quenched and Tempered.
- QUIC-CHECK® deformation and angle indicators forged on the hook.
- Fluorescent yellow finish for high "subsea" visibility.
- Tip extension allows for easy handling.
- Sizes 3.2t through 31.5t utilize new integrated latch (S-4320) that meets the world-class standard for lifting.
  - Heavy duty stamped latch interlocks with the hook tip.
  - High cycle, long life spring.
- Pad eyes are provided on either side of hook as cable guides. The cable is passed through a hole drilled in the latch that assists in allowing the "remotely operated" cable to open latch.
- Cables and drilled latches are not provided by Crosby. They can be fitted by your local Authorized Crosby Dealer.

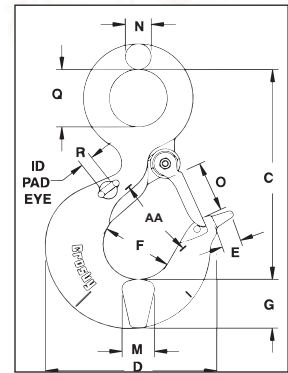

**L-320R ROV Hooks**

Working Load Limit (t)	Hook ID Code	L-320R Stock No.	Weight Each (kg)	Dimensions (mm)											Replacement Latch Stock No.
				C	D	E	F	G	M	N	O	Q	R	AA**	
†3.2	HA	1298427	1.01	119	101	25	41	29	24	15	28	32	6	50.8	1096468
†5.4	IA	1298497	2.04	147	122	25	51	37	33	18	35	40	6	63.5	1096515
†8	JA	1298567	3.92	187	159	35	64	46	42	23	41	51	10	76.2	1096562
†11.5	KA	1298637	7.02	230	189	35	76	57	41	28	53	62	10	102	1096611
†16	LA	1298707	10.1	256	211	35	83	66	49	32	58	72	10	102	1096657
†22	NA	1298777	18.4	318	262	45	108	76	60	40	77	89	19	127	1096704
†31.5	OA	1298847	28.1	357	346	-	127	92	76	44	93	89	19	165	1090161
37	PA	1298857	48.5	462	357	-	137	116	81	51	95	114	19	178	1090189
45	SA	1298867	62.1	511	392	-	152	129	82	55	114	125	19	203	1090189
60	TA	1298877	102	602	470	-	178	152	99	64	130	145	19	254	1090205

\*Minimum Ultimate Load is 4 times the Working Load Limit. \*\* Deformation Indicators. † Utilizes Crosby S320N style hook.

**ROV PRODUCTS**

Developed in conjunction with major North Sea subsea operations.

For efficient load handling and attachment for Remote Operating Vehicles in subsea and other hard-to-reach applications.

Pad eyes are placed on either side of hook as cable guides which allows the "remotely operated" cable to open latch.

Available on pages: 90, 91.



L-320R  
ROV EYE  
HOOK



G-209R  
ROV SHACKLE



L-562A  
ROV EYE  
SHANK  
HOOK



# Crosby® ROV Eye Shank Hooks



L-562A  
ROV Eye  
Shank Hook

- Hook identification code stamped on each hook.
- Quenched and Tempered.
- QUIC-CHECK® angle indicators forged into the top eye; and deformation and angle indicators forged on the hook.
- Fluorescent yellow finish for high “subsea” visibility.
- Tip extension allows for easy handling.
- Sizes 5.4t through 31.5t utilize new integrated latch (S-4320) that meets the world-class standard for lifting.
  - Heavy duty stamped latch interlocks with the hook tip.
  - High cycle, long life spring.
- Pad eyes are provided on either side of hook as cable guides. The cable is passed through a hole drilled in the latch that assists in allowing the “remotely operated” cable to open latch.
- Cables and drilled latches are not provided by Crosby. They can be fitted by your local Authorized Crosby Dealer.

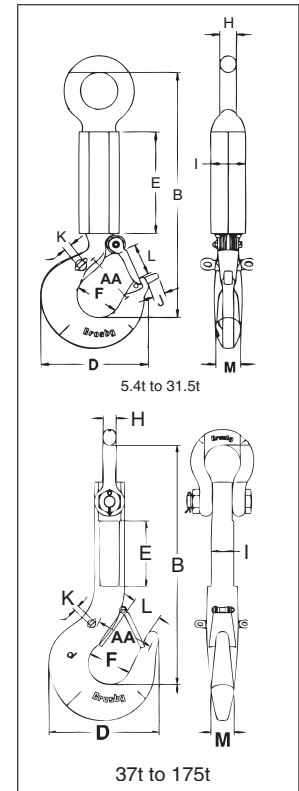

**Fatigue Rated**

**Load Rated**

CE

QT

QUIC-CHECK®

**SEE APPLICATION AND WARNING INFORMATION**  
On Pages 153 - 154  
Para Español: [www.thecrosbygroup.com](http://www.thecrosbygroup.com)

## L-562A ROV Eye Shank Hooks

Working Load Limit (t)	Hook ID Code	L-562A Stock No.	Weight Each (kg)	Dimensions (mm)											Replacement Latch Stock No.
				I	E	B	D	J	F	M	H	L	K	AA**	
†5.4	IA	1297722	9.5	65	250	421	123	9.9	51	29	22	35	6.4	63.5	1096515
†11.5	KA	1297792	15	65	250	518	192	30	76	41	32	53	9.7	101	1096611
†16	LA	1297806	18	65	250	550	212	30	83	49	35	58	9.7	101	1096657
†22	NA	1297862	31	85	250	608	263	45	108	60	40	77	19	127	1096704
†31.5	OA	1298042	44	85	250	660	346	-	127	76	48	106	19	165	1090161
‡37	PA	1298049	44	80	235	828	357	-	137	76	47	95	19	177	1090189
‡45	SA	1298057	90	80	235	865	392	-	152	83	47	108	19	203	1090189
‡60	TA	1298087	131	90	215	941	470	-	178	99	53	130	19	254	1090205
‡100	WA	1298103	303	140	300	1185	584	-	173	140	69	124	19	305	1090241
‡150	XA	1298117	395	150	230	1233	619	-	171	152	92	137	19	330	1090241
**175	YA	1298130	515	170	255	1326	678	-	191	178	102	-	19	330	143062

\*Minimum Ultimate Load is 4 times the Working Load Limit. \*\* Deformation Indicators. ‡Utilize Crosby G-2140 shackle as eye. † Utilizes Crosby S319N style hook.

**HOOKS & SWIVELS**



A-350N  
Sliding Choker Hook

- New style incorporates throat opening equal to or larger than old style hooks.
- Each product has a Product Identification Code (PIC) for material traceability, along with a Working Load Limit, and the name Crosby or "CG" forged into it.
- All hooks incorporate Crosby's patented QUIC-CHECK® marks to help in determining if throat opening dimension has changed.
- Each hook can be equipped with a Crosby S-4320 heavy duty stamped latch with the high cycle, long life spring.
- Forged Alloy Steel -- Quenched and Tempered.
- Design Factor of 5 to 1

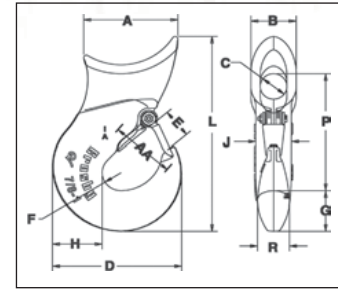

**A-350N Sliding Choker Hook**

Single Part Rope Size (in.-mm)	Eight Part Rope Size (mm)	A-350N Stock No.	A-350L Stock No.	Weight Each (kg)	Dimensions (mm)											Hook Frame Code	Replacement Latch Kit Stock No.	
					A	B	C	D	E	F	G	H	L	P	R			AA**
3/8 - 10	-	1011707	1011802	.35	52.5	28.7	16.0	61.0	16.0	9.65	21.3	23.1	109	66.0	16.0	38.1	D	1096325
1/2 - 13	3	1011716	1011811	.54	57.0	33.3	19.1	75.5	19.8	12.7	24.6	26.9	126	78.5	19.1	38.1	F	1096374
† 5/8 - 16	-	1011725	1011820	1.31	77.5	41.4	19.1	90.5	23.9	14.2	28.7	33.3	162	98.5	25.4	50.8	G	1096421
† 5/8 - 16	4	1011734	1011839	1.22	77.5	41.4	25.4	90.5	23.9	14.2	28.7	33.3	162	102	28.7	50.8	G	1096421
† 3/4 - 20	-	1011743	1011848	2.35	86.0	54.0	25.4	108	29.5	16.0	36.6	41.4	195	116	28.7	63.5	H	1096468
† 3/4 - 20	6-7	1011752	1011857	2.27	86.0	54.0	36.6	108	29.5	16.0	36.6	41.4	195	121	28.7	63.5	H	1096468
†† 22-25	-	1028177	1028177	4.40	112	53.8	31.8	154	35.8	22.4	51.0	59.2	243	145	38.1	76.2	I	1096515

\*Ultimate Load is 5 times the Working Load Limit. \*\* Deformation Indicators. † Determine EYE diameter "C", before ordering. †† 7/8-1" is Cast Steel & furnished with latch attached.

**Did You Know...**

there are three indicators built into almost every Crosby hook?

- **Deformation Indicator:** for abuse and overload.
- **Angle Indicators:** insure the maximum include angle which is allowed between two (2) sling legs.
- **Two Letters Code:** One letter represents the size and weight of the hook. The other letter tells you what material the hook is made of.





# Crosby® Forged Hooks



**G-3315  
Snap Hook**

- Forged Carbon Steel -- Quenched and Tempered.
- Pressed steel latches and stainless steel springs, bolts and nuts.
- For replacement latch kit, order Stock No. 9900299.
- Hook Body -- Galvanized.

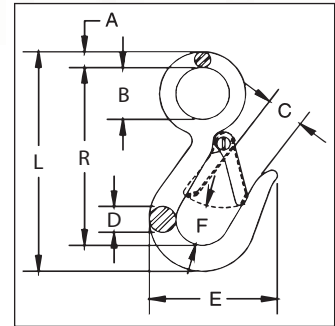

## G-3315 Snap Hook

Hook Size (mm)	G-3315 Stock No.	Working Load Limit (t)*	Weight Each (kg)	Dimensions (mm)							
				A	B	C	D	E	F	L	R
12	1023056	.34	.11	6.35	19.1	19.1	11.2	57.0	19.1	100	82.5
14	1023074	.45	.22	8.65	28.4	20.6	14.2	68.5	22.4	120	97.5

\*Ultimate Load is 4 times the Working Load Limit.



**1210 Round Reverse Eye Hook**

- Forged Carbon Steel -- Galvanized.

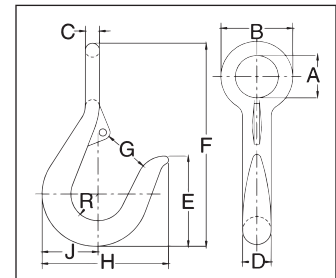

## 1210 Round Reverse Eye Hook

Size (mm)	1210 Stock No.	Working Load Limit (Tons)*	Weight Each (kg)	Latch Stock No.	Dimensions (mm)									
					A	B	C	D	E	F	G	H	J	R
13	919019	.14	.18	1090027	20.6	35.1	7.10	12.7	41.1	102	19.1	57.0	24.6	11.9
16	919037	.18	.27	1090027	23.9	39.6	7.85	15.7	51.0	114	23.9	70.0	31.0	15.0
19	919055	.31	.50	1090045	28.4	47.8	9.65	19.1	57.0	133	26.9	76.0	36.6	17.5
22	919073	.54	.73	1096468	30.2	52.5	11.2	22.4	76.0	165	31.8	86.0	41.4	19.1
26-28	919091	.82	.91	1090081	38.1	70.0	15.7	28.4	89.0	203	38.1	111	51.0	23.9
31-36	919135	1.2	2.49	1090081	47.8	89.0	20.6	35.1	102	232	41.1	127	60.5	26.9

\*Ultimate Load is 4 times the Working Load Limit.



**S-377  
Barrel Hooks**

- Forged Carbon Steel - Quenched and Tempered.
- Meets the performance requirements of Federal Specification RR-C-271F, Type V, Class 6, except for those provisions required of the contractor.



## S - 377 Barrel Hooks

Working Load Limit Per Pair (t)*	S-377 Stock No. Per Pair	Weight Each Per Pair (kg)	Dimensions (mm)			
			I.D. of Eye	O.D. of Eye	Overall Length	Width of Lip
1	1028248	1.61	39.6	71.4	127	73.2



S-3316  
Replacement Hook

- Easily attaches to any chain and electric hoist with welded link load chain, roller chain or wire rope with suitable end fitting.
- Swivel jaw is forged.
- Suitable for infrequent, non-continuous rotation under load.
- Use in corrosive environment requires shank and nut inspection in accordance with ASME B30.10-1.10.4(b)(5)(c)2009.

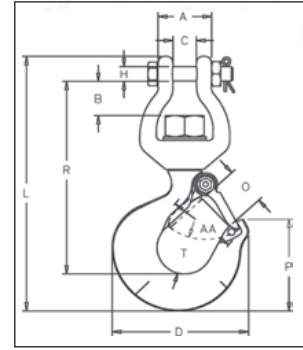

**S-3316 Replacement Hook**

Working Load Limit (t)*	Frame Code	S-3316 Stock No	Weight Each (kg)	Dimensions (mm)										Replacement Latch Kit Stock No.
				A	B	C	D	H	L	O	P	R	T	
.45	F	1023029	.57	33.3	19.3	14.2	81.0	9.65	155	24.6	57.0	117	20.6	1096374
.91	H	1023047	1.18	39.6	25.4	17.5	104	11.2	195	28.4	72.0	148	30.2	1096468

\*Ultimate Load is 5 times the Working Load Limit.



A-378  
Sorting Hook

- Forged Alloy Steel - Quenched and Tempered.
- Deep straight throat permits efficient handling of flat plates or large cylindrical shapes.



A-378  
Sorting Hook

**A-378 Sorting Hook**

Working Load Limit at tip of Hook (t)*	Working Load Limit at bottom of Hook (t)*	A-378 Stock No	Style	Weight Each (kg)	Dimensions (mm)			
					I.D. of Eye	Overall Length	Opening at top of Hook	Radius at bottom of Hook
1.8	6.8	1028024	No Handle	2.91	35.0	246	71.4	15.9
1.8	6.8	1028033	With Handle	2.91	35.0	246	71.4	15.9

\*Ultimate Load is 4 times the Working Load Limit.





## Forged Swivels

- Hot dip Galvanized
- Quenched & Tempered
- Crosby products meet or exceed all requirements of ASME B30.26 including identification, ductility, design factor, proof load and temperature requirements. Importantly, Crosby products meet other critical performance requirements, including fatigue life, impact properties and material traceability, not addressed by ASME B30.26.

401, 402 and 403 swivels are positioning devices and are not intended to rotate under load. For load swivels see pages 136-140. Use in corrosive environment requires shank and nut inspection in accordance with ASME B30.10-1.10.4(b)(5)(c)2009.

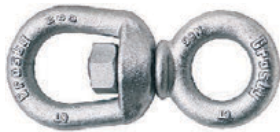

## G-401 Chain Swivels

Meets the performance requirements of Federal Specification RR-C-271F, Type VII, Class 1, except for those provisions required of the contractor. For more information, see page 452.

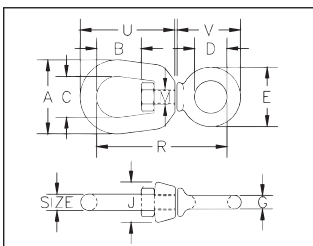

Size (mm)	G-401 Stock No.	Working Load Limit (t)*	Weight Each (kg)	Dimensions (mm)										
				A	B	C	D	E	G	J	M	R	U	V
6	1016233	.39	.06	31.8	17.5	19.1	15.7	28.4	6.35	17.5	7.85	57.0	42.9	31.8
8	1016251	.57	.11	41.4	20.6	25.4	19.1	35.1	7.85	20.6	9.65	69.0	52.5	37.3
10	1016279	1.02	.24	51.0	23.9	31.8	25.4	44.5	9.65	25.4	12.7	87.5	63.5	47.8
13	1016297	1.63	.51	63.5	33.3	38.1	31.8	57.0	12.7	33.3	16.0	108	81.0	62.0
16	1016313	2.36	.95	76.2	39.6	44.5	38.1	70.0	15.8	38.1	19.1	130	98.5	74.5
19	1016331	3.27	1.40	89.0	44.5	51.0	44.5	82.5	19.1	47.8	22.4	147	125	88.0

\*Ultimate Load is 5 times the Working Load Limit.



6 - 32mm size

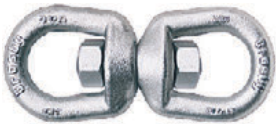

38mm size

## G-402 Regular Swivels

Meets the performance requirements of Federal Specification RR-C-271F, Type VII, Class 1, except for those provisions required of the contractor. For more information, see page 452.

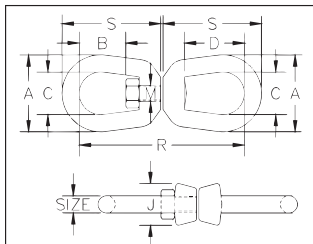

Size (mm)	G-402 Stock No.	Working Load Limit (t)*	Weight Each (kg)	Dimensions (mm)									
				A	B	C	D	J	M	R	S		
6	1016019	.39	.10	31.8	17.5	19.1	26.9	17.5	7.85	74.5	42.9		
8	1016037	.57	.18	41.4	20.6	25.4	31.8	20.6	9.65	90.0	52.0		
10	1016055	1.02	.32	51.0	23.9	31.8	38.1	25.4	12.7	109	63.5		
13	1016073	1.63	.60	63.5	33.3	38.1	51.0	33.3	16.0	138	81.0		
16	1016091	2.36	1.13	76.0	39.5	44.5	60.5	38.1	19.1	167	98.5		
19	1016117	3.27	1.82	89.0	44.5	51.0	67.0	47.8	22.4	183	109		
22	1016135	4.54	2.83	102	52.0	57.0	77.5	54.0	25.4	213	127		
25	1016153	5.67	4.06	114	58.5	63.5	89.0	60.5	28.7	245	146		
32	1016199	8.16	7.42	143	68.5	79.5	93.5	76.0	38.1	291	172		
38	1016215	20.5	20.8	180	98.5	104	98.5	95.2	57.0	424	252		

\*Ultimate Load is 5 times the Working Load Limit. + Manufactured with two 38mm bails connected by a stud with a nut on each side.



## G-403 Jaw End Swivels

Meets the performance requirements of Federal Specification RR-C-271F, Type VII, Class 3, except for those provisions required of the contractor. For more information, see page 452.

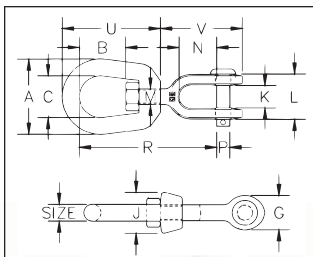

Size (mm)	G-403 Stock No.	Working Load Limit (t)*	Weight Each (kg)	Dimensions (mm)												
				A	B	C	G	J	K	L	M	N	P	R	U	V
6	1016395	.39	.10	31.8	17.5	19.1	17.5	11.9	26.2	7.85	22.4	6.35	67.0	42.9	42.9	
8	1016411	.57	.15	41.4	20.6	25.4	20.6	12.7	28.7	9.65	22.4	7.85	74.5	52.0	46.0	
10	1016439	1.02	.30	51.0	23.9	31.8	25.4	16.0	35.8	12.7	26.9	9.65	92.0	63.5	57.0	
13	1016457	1.63	.61	63.5	33.3	38.1	33.3	19.1	44.5	16.0	33.3	12.7	114	81.0	73.0	
16	1016475	2.36	1.12	76.0	39.5	44.5	41.4	38.1	23.9	52.0	19.1	38.1	16.0	135	98.5	
19	1016493	3.27	1.76	89.0	44.5	51.0	47.8	47.8	28.7	64.5	22.4	44.5	19.1	154	109	
22	1016518	4.54	2.66	102	52.0	57.0	54.0	54.0	34.0	70.9	25.4	52.0	22.4	178	127	
25	1016536	5.67	4.46	114	58.5	63.5	67.0	60.5	44.5	94.5	28.7	71.5	28.7	217	146	
32	1016572	8.16	7.14	145	68.5	79.5	79.5	76.0	52.0	109	41.4	71.5	35.1	248	179	
38+	1016590	20.5	24.8	178	98.5	102	143	102	73.0	152	57.0	113	57.0	362	254	

\*Ultimate Load is 5 times the Working Load Limit.



**Equipped with Tapered Roller Thrust Bearing**

- Suitable for frequent rotation under load.
- All swivels individually proof tested with labeled documentation.
- All hooks furnished with latches assembled.
- All jaws complete with bolts, nuts and cotter pins.
- Pressure lube fitting provided.
- **NOT TO BE USED ON DEMOLITION (WRECKING) BALLS.**
- Other types and capacities up to 1250t, available to meet your requirements.
- **IMPORTANT - Crosby Swivels should only be used with the recommended wire rope. Contact the wire rope manufacturer for the proper wire rope to be used with Crosby Swivels.**



**S-1 Jaw & Hook**

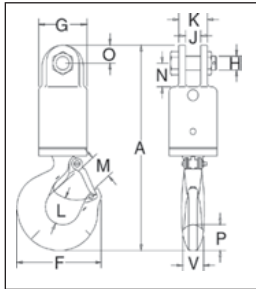

Swivel No.	S-1 Stock No.	Working Load Limit (t)*	Wire Rope Size (mm)	Weight Each (kg)	Dimensions (mm)												
					A	F	G	H	J	K	L	M	N	O	P	V	
3-S-1	297011	3	13	4.45	291	123	70.0	19.1	22.4	41.1	38.9	35.8	33.3	25.4	36.6	28.4	
5-S-1	297217	5	16	7.04	339	160	76.0	22.4	25.4	57.0	49.3	42.9	41.1	28.4	46.0	36.6	
8-S-1	297413	8-1/2	19	13.3	418	192	102	25.4	39.5	71.5	62.5	56.5	54.0	35.1	57.0	41.1	
10-S-1	297618	10	22	21.2	502	212	114	38.1	44.5	86.0	66.0	61.0	89.0	44.5	66.0	49.3	
15-S-1	297814	15	26	33.5	565	263	127	38.1	44.5	86.0	71.5	81.0	89.0	44.5	76.0	60.5	
25-S-1	298118	25	-	64	680	346	152	51.0	51.0	117	87.5	92.0	93.5	60.5	93.0	76.0	
35-S-1	298216	35	-	100	760	357	165	51.0	51.0	117	98.5	95.5	93.5	60.5	116	81.0	
45-S-1	298314	45	-	114	891	392	178	57.0	63.5	127	121	108	102	76.0	129	82.5	

\*Individually Proof Tested to 2 times the Working Load Limit. Ultimate Load is 5 times the Working Load Limit.

**S-2 Jaw & Jaw**

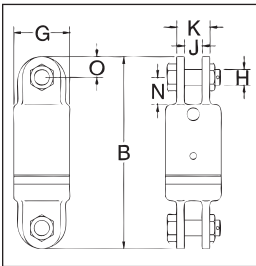

Swivel No.	S-2 Stock No.	Working Load Limit (t)*	Wire Rope Size (mm)	Weight Each (kg)	Dimensions (mm)						
					B	G	H	J	K	N	O
3-S-2	297020	3	13	4.37	236	70.0	19.1	22.4	41.1	33.3	25.4
5-S-2	297226	5	16	6.21	262	76.0	22.4	25.4	57.0	41.1	28.4
8-S-2	297422	8-1/2	19	11.9	321	102	25.4	39.5	71.5	54.0	35.1
10-S-2	297627	10	22	20.8	426	114	38.1	44.5	86.0	89.0	44.5
15-S-2	297823	15	26	28.5	435	127	38.1	44.5	86.0	89.0	44.5
25-S-2	298127	25	-	64	527	152	51.0	51.0	117	93.5	60.5
35-S-2	298225	35	-	70	527	165	51.0	51.0	117	93.5	60.5
45-S-2	298323	45	-	107	641	178	57.0	63.5	127	102	76.0

\*Individually Proof Tested to 2 times the Working Load Limit. Ultimate Load is 5 times the Working Load Limit.

**S-3 Jaw & Eye**

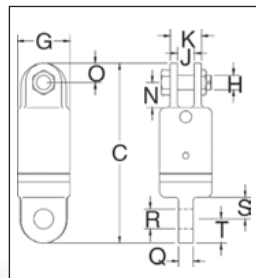

Swivel No.	S-3 Stock No.	Working Load Limit (t)*	Wire Rope Size (mm)	Weight Each (kg)	Dimensions (mm)										
					C	G	H	J	K	N	O	Q	R	S	T
3-S-3	297039	3	13	4.14	237	70.0	19.1	22.4	41.1	33.3	25.4	19.1	26.2	28.4	31.8
5-S-3	297235	5	16	6.12	256	76.0	22.4	25.4	57.0	41.1	28.4	25.4	32.5	31.8	31.8
8-S-3	297431	8-1/2	19	11.3	311	102	25.4	39.5	71.5	54.0	35.1	31.8	35.8	41.1	38.1
10-S-3	297636	10	22	19.7	409	114	38.1	44.5	86.0	89.0	44.5	42.9	42.9	70.0	47.8
15-S-3	297832	15	26	27.7	425	127	38.1	44.5	86.0	89.0	44.5	49.3	51.5	70.0	54.0
25-S-3	298136	25	-	61	546	152	51.0	51.0	117	93.5	60.5	57.0	58.5	98.5	60.5
35-S-3	298234	35	-	68	546	165	51.0	51.0	117	93.5	60.5	57.0	58.5	98.5	60.5
45-S-3	298332	45	-	102	657	178	57.0	63.5	127	102	76.0	63.5	64.5	102	76.0

\*Individually Proof Tested to 2 times the Working Load Limit. Ultimate Load is 5 times the Working Load Limit.





S-4 Eye & Jaw

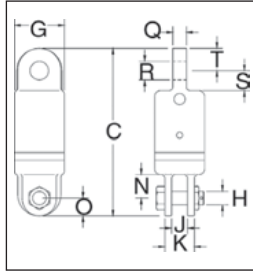

Swivel No.	S-4 Stock No.	Working Load Limit (t)*	Wire Rope Size (mm)	Weight Each (kg)	Dimensions (mm)										
					C	G	H	J	K	N	O	Q	R	S	T
3-S-4	297048	3	13	4.08	237	70.0	19.1	22.4	41.1	33.3	25.4	19.1	26.2	28.4	31.8
5-S-4	297244	5	16	5.60	256	76.0	22.4	25.4	57.0	41.1	28.4	25.4	32.5	31.8	31.8
8-S-4	297440	8-1/2	19	13.2	311	102	25.4	39.5	71.5	54.0	35.1	31.8	35.8	41.1	38.1
10-S-4	297645	10	22	20.0	409	114	38.1	44.5	86.0	89.0	44.5	42.9	42.9	70.0	47.8
15-S-4	297841	15	26	27.7	425	127	38.1	44.5	86.0	89.0	44.5	49.3	51.5	70.0	54.0
25-S-4	298145	25	-	61	546	152	51.0	51.0	117	93.5	60.5	57.0	58.5	98.5	60.5
35-S-4	298243	35	-	68	546	165	51.0	51.0	117	93.5	60.5	57.0	58.5	98.5	60.5
45-S-4	298341	45	-	102	657	178	57.0	63.5	127	102	76.0	63.5	64.5	102	76.0

\*Individually Proof Tested to 2 times the Working Load Limit. Ultimate Load is 5 times the Working Load Limit.

S-5 Eye & Eye

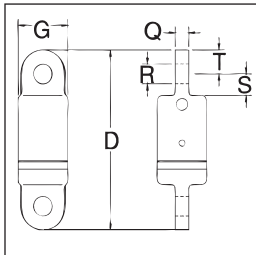

Swivel No.	S-5 Stock No.	Working Load Limit (t)*	Wire Rope Size (mm)	Weight Each (kg)	Dimensions (mm)					
					D	G	Q	R	S	T
3-S-5	297057	3	13	3.86	239	70.0	19.1	26.2	28.4	31.8
5-S-5	297253	5	16	5.13	249	76.0	25.4	32.5	31.8	31.8
8-S-5	297459	8-1/2	19	13.3	302	102	31.8	35.8	41.1	38.1
10-S-5	297654	10	22	19.1	394	114	42.9	42.9	70.0	47.8
15-S-5	297850	15	26	22.2	416	127	49.3	51.5	70.0	54.0
25-S-5	298154	25	-	59	565	152	57.0	58.5	98.5	60.5
35-S-5	298252	35	-	66	565	165	57.0	58.5	98.5	60.5
45-S-5	298350	45	-	98	673	178	63.5	64.5	102	76.0

\*Individually Proof Tested to 2 times the Working Load Limit. Ultimate Load is 5 times the Working Load Limit.

S-6 Eye & Hook

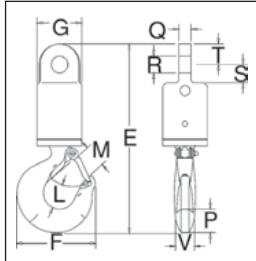

Swivel No.	S-6 Stock No.	Working Load Limit (t)*	Wire Rope Size (mm)	Weight Each (kg)	Dimensions (mm)										
					E	F	G	L	M	P	Q	R	S	T	V
3-S-6	297066	3	13	4.23	292	123	70.0	38.9	35.8	36.6	19.1	26.2	28.4	31.8	28.4
5-S-6	297262	5	16	6.46	332	160	76.0	49.3	42.9	46.0	25.4	32.5	31.8	31.8	36.6
8-S-6	297468	8-1/2	19	14.5	408	192	102	62.5	56.5	57.0	31.8	35.8	41.1	38.1	41.1
10-S-6	297663	10	22	20.6	486	212	114	66.0	61.0	66.0	42.9	42.9	70.0	47.8	49.3
15-S-6	297869	15	26	28.6	540	263	127	71.5	81.0	76.0	49.3	51.5	70.0	54.0	60.5
25-S-6	298163	25	-	61	699	346	152	87.5	92.0	93.0	57.0	58.5	98.5	60.5	76.0
35-S-6	298261	35	-	98	780	357	165	98.5	95.5	116	57.0	58.5	98.5	60.5	81.0
45-S-6	298369	45	-	122	907	392	178	121	108	129	63.5	64.5	102	76.0	82.5

\*Individually Proof Tested to 2 times the Working Load Limit. Ultimate Load is 5 times the Working Load Limit.

**NOTE:** For swivels larger than 45 metric tons, or designed to meet the requirements of demanding applications such as subsea applications, please contact the Crosby Special Engineered Products Department. For additional information concerning custom design products, contact:  
 In U.S.A. - Crosby's Special Engineered Products Group at 1-800-777-1555, Fax (918) 834-5035.  
 In Canada - Crosby Canada at (905) 451-9261.  
 In Europe - N.V. Crosby Europe at +32 15 75 71 25.

# Crosby® Angular Contact Bearing Swivels



## Angular Contact Bearing Swivels

- Wide range of product available.
  - Capacity: 0.40 through 31.5 tonnes
  - Wire Rope Sizes: 2mm through 38mm
- Individually Proof Tested to 2 times the Working Load Limit with certification.
- Design Factor of 5 to 1.
- Entire swivel is Zinc plated to resist corrosion.
- Angular contact bearings maximize efficiency, reliability and service life of swivel and extend the life of the wire rope.
- Designed for high rotation speed: Lower torque required to initiate rotation.
- Hook models utilize genuine Crosby hooks which are forged alloy steel, Quenched and Tempered and contain patented QUIC-CHECK® markings.
- Each swivel, 7.65 tonnes and larger is furnished with a pressure lubrication fitting.

Wire Rope Size (mm)	AS-20 Stock No.
13	1038200
16	1038209
19	1038218
22-25	1038227
28-32	1038236
38	1038245

## AS-20 Thimble Insert

- When terminating with wire rope clips, we recommend the use of the Thimble Insert. The result will be extended wire rope life.
- Allows standard swivel to be used in application requiring a thimble fitting.
- For use with our Bullet Style (AS-7) and Jaw Style (AS-1, AS-2, AS-3 & AS-4) swivels.
- Machined from carbon steel. Zinc plated.

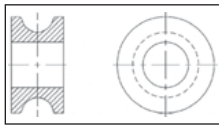

## AS-1 Jaw & Hook

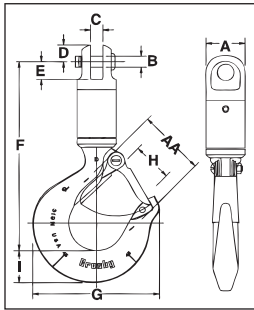

AS-1 JAW & HOOK				Dimensions (mm)									Deformation Indicator AA	Replacement Latch Kit Stock No.
Working Load Limit (t)*	Wire Rope Size (mm)	AS-1 Stock No.	Weight Each (kg)	A	B	C	D	E	F	G	H	I		
.40	3	1016001	.32	22.4	6.35	6.35	9.65	10.4	110	72.5	23.6	18.5	38.1	1096325
.68	6	1016010	.68	33.3	9.65	7.85	11.2	14.2	138	80.0	24.6	21.3	38.1	1096374
1.35	10	1016025	1.04	41.4	12.7	12.7	17.5	19.8	161	102	29.5	29.0	38.1	1096374
2.70	13	1016026	2.95	51.0	19.1	19.1	23.9	30.2	221	123	35.8	36.6	63.5	1096374
4.50	16	1016040	5.85	63.5	22.4	25.4	28.7	38.9	272	160	42.9	46.2	76.0	1096562
7.65	19	1016045	12.0	76.0	30.2	39.5	34.0	53.0	347	212	61.0	66.0	102	1096657
9.00	22	1016056	24.0	102	38.1	44.5	44.5	89.0	456	263	81.0	76.0	127	1096704
13.5	25	1016064	24.0	102	38.1	44.5	44.5	89.0	456	263	81.0	76.0	127	1096704
22.5	32	1016075	44.0	127	51.0	51.0	60.5	93.5	530	346	82.5	92.0	165	1090161
31.5	38	1016082	63.5	127	51.0	51.0	60.5	93.5	610	357	76.0	116	178	1090189

\*Ultimate Load is 5 times the Working Load Limit. Individually Proof Tested to 2 times the Working Load Limit.

## AS-2 Jaw & Jaw

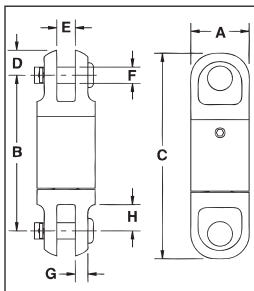

AS-2 JAW & JAW				Dimensions (mm)							
Working Load Limit (t)*	Wire Rope Size (mm)	AS-2 Stock No.	Weight Each (kg)	A	B	C	D	E	F	G	H
.40	3	1016103	.18	22.4	60.5	79.5	9.65	6.35	6.35	4.80	10.4
.68	6	1016114	.41	33.3	90.0	113	11.2	7.85	9.65	5.60	14.2
1.35	10	1016122	.91	41.4	103	138	17.5	12.7	12.7	7.10	19.8
2.70	13	1016131	2.22	51.0	159	207	23.9	19.1	19.1	9.65	30.2
4.50	16	1016139	4.35	63.5	197	270	28.7	25.4	22.4	13.5	38.9
7.65	19	1016148	7.17	76.0	245	313	34.0	39.5	30.2	14.2	53.0
9.00	22	1016157	18.1	102	356	445	44.5	44.5	38.1	20.6	89.0
13.5	25	1016166	18.1	102	356	445	44.5	44.5	38.1	20.6	89.0
22.5	32	1016175	35.4	127	405	526	60.5	51.0	51.0	28.7	93.5
31.5	38	1016184	35.4	127	405	526	60.5	51.0	51.0	28.7	93.5

\*Ultimate Load is 5 times the Working Load Limit. Individually Proof Tested to 2 times the Working Load Limit.

For swivels larger than 45 metric tons, or for swivels designed to meet the requirements of demanding applications (i.e., subsea applications), please contact the Crosby Special Engineered Products Department. For additional information concerning custom design products, contact:  
 U.S.A., Crosby's Special Engineered Products Group at 1-800-777-1555, Fax (918) 834-5035  
 Canada, Crosby Canada at (905) 451-9261  
 Europe, N.V. Europe at +32 15 75 71 25.





## AS-3 Jaw & Eye

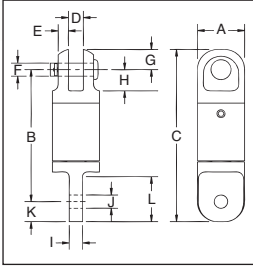

AS-3 JAW & EYE				Dimensions (mm)											
Working Load Limit (t)*	Wire Rope Size (mm)	AS-3 Stock No.	Weight Each (kg)	A	B	C	D	E	F	G	H	I	J	K	L
.40	3	1016205	.14	22.4	63.5	82.5	6.35	4.80	6.35	9.65	10.4	6.35	6.35	9.65	21.3
.68	6	1016216	.41	33.3	93.5	116	7.85	5.60	9.65	11.2	14.2	7.85	9.65	11.0	22.4
1.35	10	1016224	.86	41.4	106	138	12.7	7.10	12.7	17.5	19.8	12.7	16.8	16.0	35.1
2.70	13	1016232	2.09	51.0	157	207	19.1	9.65	19.1	23.9	30.2	19.1	23.1	25.0	51.0
4.50	16	1016243	4.13	63.5	200	259	25.4	13.5	22.4	28.7	38.1	25.4	31.8	30.0	67.0
7.65	19	1016250	7.08	76.0	241	311	39.5	14.2	31.8	34.0	53.0	31.8	35.8	38.0	79.5
9.00	22	1016259	17.7	102	349	440	44.5	20.6	38.1	44.5	89.0	43.7	41.4	46.0	119
13.5	25	1016268	18.1	102	341	440	44.5	20.6	38.1	44.5	89.0	51.0	51.0	54.0	119
22.5	32	1016277	35.4	127	406	527	51.0	28.7	51.0	60.5	93.5	57.0	58.5	61.0	133
31.5	38	1016286	35.4	127	406	527	51.0	28.7	51.0	60.5	93.5	57.0	58.5	61.0	133

\*Ultimate Load is 5 times the Working Load Limit. Individually Proof Tested to 2 times the Working Load Limit.

## AS-4 Eye & Jaw

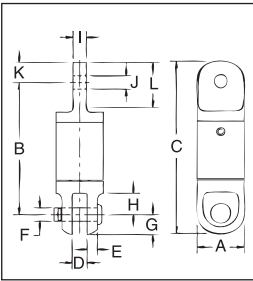

AS-4 EYE & JAW				Dimensions (mm)											
Working Load Limit (t)*	Wire Rope Size (mm)	AS-4 Stock No.	Weight Each (kg)	A	B	C	D	E	F	G	H	I	J	K	L
.40	3	1016306	.14	22.4	63.5	82.5	6.35	4.80	6.35	9.65	10.4	6.35	6.35	9.65	20.6
.68	6	1016314	.41	33.3	92.0	116	7.85	5.60	9.65	11.2	14.2	7.85	9.65	11.0	22.4
1.35	10	1016325	.86	41.4	106	140	12.7	7.10	12.7	17.5	19.8	12.7	16.8	16.0	34.0
2.70	13	1016332	2.09	51.0	157	207	19.1	9.65	19.1	23.9	30.2	19.1	23.1	25.4	51.0
4.50	16	1016343	4.13	63.5	200	259	25.4	13.5	22.4	28.7	36.6	25.4	31.8	30.2	67.0
7.65	19	1016352	7.12	76.0	240	311	39.5	14.2	30.2	34.0	53.0	31.8	35.8	38.1	79.5
9.00	22	1016361	17.7	102	359	451	44.5	20.6	38.1	44.5	89.0	43.7	42.2	46.0	119
13.5	25	1016370	18.1	102	351	451	44.5	20.6	38.1	44.5	89.0	51.0	51.5	54.0	119
22.5	32	1016375	34.0	127	405	527	51.0	28.7	51.0	60.5	93.5	57.0	58.5	60.5	133
31.5	38	1016379	34.0	127	405	527	51.0	28.7	51.0	60.5	93.5	57.0	58.5	60.5	133

\*Ultimate Load is 5 times the Working Load Limit. Individually Proof Tested to 2 times the Working Load Limit.

## AS-5 Eye & Eye

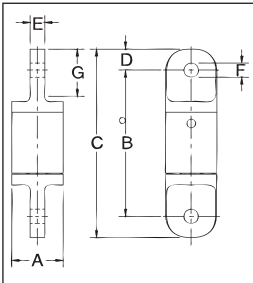

AS-5 EYE & EYE				Dimensions (mm)						
Working Load Limit (t)*	Wire Rope Size (mm)	AS-5 Stock No.	Weight Each (kg)	A	B	C	D	E	F	G
.40	3	1016409	.14	22.4	67.0	86.0	9.65	6.35	6.35	20.6
.68	6	1016418	.41	33.3	95.0	118	11.2	7.85	9.65	22.4
1.35	10	1016427	.82	41.4	110	141	16.0	12.7	16.8	34.0
2.70	13	1016436	1.95	51.0	156	207	25.4	19.1	23.1	51.0
4.50	16	1016445	3.90	63.5	197	270	30.2	25.4	31.8	67.0
7.65	19	1016454	7.00	76.0	237	313	38.1	31.8	35.8	79.5
9.00	22	1016463	16.8	102	353	445	46.0	43.7	41.4	119
13.5	25	1016472	17.7	102	337	445	54.0	51.0	54.0	119
22.5	32	1016481	32.7	127	406	527	60.5	57.0	58.5	133
31.5	38	1016490	32.7	127	406	527	60.5	57.0	58.5	133

\*Ultimate Load is 5 times the Working Load Limit. Individually Proof Tested to 2 times the Working Load Limit.

## AS-6 Eye & Hook

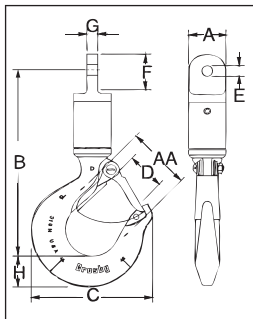

AS-6 EYE & HOOK				Dimensions (mm)								Deformation Indicator AA	Replacement Latch Kit Stock No.
Working Load Limit (t)*	Wire Rope Size (mm)	AS-6 Stock No.	Weight Each (kg)	A	B	C	D	E	F	G	H		
.40	3	1016502	.32	22.4	111	72.5	23.6	6.35	20.6	6.35	18.5	38.1	1096325
.68	6	1016513	.68	33.3	141	80.0	24.6	9.65	22.4	7.85	21.3	38.1	1096374
1.35	10	1016520	1.32	41.4	158	102	29.5	16.8	34.0	12.7	29.0	51.0	1096374
2.70	13	1016529	2.81	51.0	219	123	35.8	23.1	51.0	19.1	36.6	63.5	1096374
4.50	16	1016538	5.62	63.5	274	160	42.9	31.8	67.0	25.4	46.2	76.0	1096562
7.65	19	1016547	10.7	76.0	343	212	61.0	35.6	79.5	31.8	66.0	102	1096657
9.00	22	1016556	23.6	102	459	263	81.0	42.2	119	43.7	76.0	127	1096704
13.5	25	1016565	24.0	102	448	263	81.0	51.5	119	51.0	76.0	127	1096704
22.5	32	1016574	42.6	127	530	346	82.9	59.0	133	57.0	92.0	165	1090161
31.5	38	1016583	62.6	127	610	357	76.0	59.0	133	57.0	116	178	1090189

\*Ultimate Load is 5 times the Working Load Limit. Individually Proof Tested to 2 times the Working Load Limit.



For swivels larger than 45 metric tons, or for swivels designed to meet the requirements of demanding applications (i.e., subsea applications), please contact the Crosby Special Engineered Products Department. For additional information concerning custom design products, contact:  
 U.S.A., Crosby's Special Engineered Products Group at 1-800-777-1555, Fax (918) 834-5035  
 Canada, Crosby Canada at (905) 451-9261  
 Europe, N.V. Europe at +32 15 75 71 25.

## AS-7 Bullet Style Jaw & Jaw

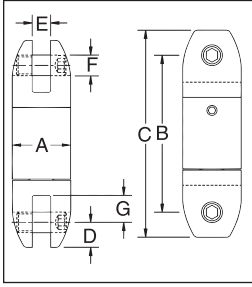

AS-7 BULLET STYLE JAW & JAW				Dimensions (mm)						
Working Load Limit (t)*	WireRope Size (mm)	AS-7 Stock No.	Weight Each (kg)	A	B	C	D	E	F	G
.40	3	1016604	.18	22.4	60.5	79.5	9.65	6.35	7.85	10.2
.68	6	1016611	.50	33.3	90.0	113	11.2	7.85	9.65	14.2
1.35	10	1016622	.82	41.4	103	132	14.2	12.7	11.2	20.6
2.70	13	1016631	1.72	51.0	138	179	20.6	19.1	16.0	23.9
4.50	16	1016640	3.63	63.5	197	256	28.7	25.4	22.4	39.5
7.65	19	1016649	6.58	76.0	251	314	31.8	33.3	25.4	54.0
9.00	22	1016652	18.1	102	334	425	44.5	44.5	38.1	82.5
13.5	25	1016658	18.1	102	334	425	44.5	44.5	38.1	82.5
22.5	32	1016662	38.1	127	405	527	60.5	51.0	51.0	93.5
31.5	38	1016667	38.1	127	405	527	60.5	51.0	51.0	93.5

\*Ultimate Load is 5 times the Working Load Limit. Individually Proof Tested to 2 times the Working Load Limit.

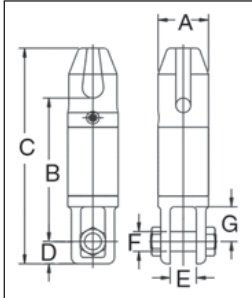

## AS-11 Thimble & Jaw

AS-11 THIMBLE & JAW				Dimensions (mm)						
Working Load Limit (t)*	WireRope Size (mm)	AS-11 Stock No.	Weight Each (kg)	A	B	C	D	E	F	G
7.65	19	1017020	12.0	76.2	22.0	330	34.0	39.6	30.2	53.1
13.5	25	1017029	24.0	102	296	445	44.5	45.0	38.1	89.0

\*Ultimate Load is 5 times the Working Load Limit. Individually Proof Tested to 2 times the Working Load Limit.

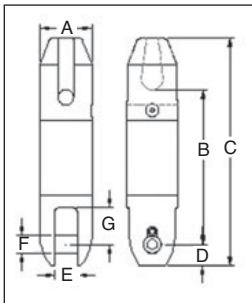

## AS-14 Thimble & Bullet

AS-14 THIMBLE & BULLET				Dimensions (mm)						
Working Load Limit (t)*	WireRope Size (mm)	AS-14 Stock No.	Weight Each (kg)	A	B	C	D	E	F	G
7.7	20	1017255	9.0	76.2	229	337	31.8	33.3	25.4	54.1
13.6	26	1017258	18.0	102	292	441	44.5	44.5	38.1	82.6
22.7	32	1017261	37.0	127	363	538	60.5	50.8	50.8	93.7

\*Ultimate Load is 5 times the Working Load Limit. Individually Proof Tested to 2 times the Working Load Limit.

## AS-17 Bullet Style Jaw & Jaw Slurry Swivel

The Crosby AS-17 Slurry Swivel is a zinc plated Bullet Type Swivel (AS-7), designed with two rubber lip style seals about the shaft. The threaded cap is sealed with a silicone sealant and secured with a set screw. The swivels are provided with an Alemite grease fitting for easy lubrication.

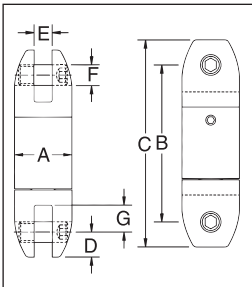

AS-17 BULLET JAW SLURRY SWIVEL				Dimensions (mm)						
Working Load Limit (t)*	WireRope Size (mm)	AS-17 Stock No.	Weight Each (kg)	A	B	C	D	E	F	G
7.65	19	8013342	6.57	76.2	257	321	31.8	33.3	25.4	54.1
13.5	25	8013343	18.1	102	343	432	44.5	44.5	38.1	82.5
22.5	32	8013376	38.1	127	410	531	60.5	51.0	51.0	93.7
31.5	38	8013344	38.1	127	410	531	60.5	51.0	51.0	93.7
40.5	-	2016585	68.0	152	514	666	76.2	64.3	57.2	69.9

\*Ultimate Load is 5 times the Working Load Limit. Individually Proof Tested to 2 times the Working Load Limit.



For swivels larger than 45 metric tons, or for swivels designed to meet the requirements of demanding applications (i.e., subsea applications), please contact the Crosby Special Engineered Products Department. For additional information concerning custom design products, contact:  
 U.S.A., Crosby's Special Engineered Products Group at 1-800-777-1555, Fax (918) 834-5035  
 Canada, Crosby Canada at (905) 451-9261  
 Europe, N.V. Europe at +32 15 75 71 25.





# S-4320 HOOK LATCH KIT

## WARNINGS & APPLICATION INSTRUCTIONS



(For Crosby 319N, 320N, and 322N, S-1327, and A-1339 Hooks)

**⚠ WARNING**

- Loads may disengage from hook if proper procedures are not followed.
- A falling load may cause serious injury or death.
- Hook must always support the load. The load must never be supported by the latch.
- See OSHA Rule 1926.1431(g)(1)(i)(A) and 1926.1501(g)(4)(iv)(B) for Personnel Hoisting by crane or derricks. A Crosby S-319N, S-320N, S-322N, S-1327, and A-1339 Hook with an S-4320 latch attached (when secured with cotter pin) may be used for lifting personnel.
- An S-4320 Latch is only to be used with a Crosby S-319N, S-320N, S-322N, S-1327, and A-1339 Hook.
- **DO NOT** use this latch in applications requiring non-sparking.
- Read and understand these instructions before using hook and latch.

### Important Safety Information - Read & Follow

- Always inspect hook and latch before using.
- Never use a latch that is distorted or bent.
- Always make sure spring will force the latch against the tip of the hook.
- Always make sure hook supports the load. The latch must never support the load. (See Figures 1 & 2.)
- When placing two (2) sling legs in hook, make sure the angle between the legs is less than 90° and if the hook or load is tilted, nothing bears against the bottom of this latch. (See Figures 3 & 4.)
- Latches are intended to retain loose sling or devices under slack conditions.
- Latches are not intended to be an anti-fouling device.
- When using latch for personnel lifting, select proper cotter pin (See Figure 5). See Step 7 below for proper installation instructions.
  - Never reuse a bent cotter pin.
  - Never use a cotter pin with a smaller diameter or different length than recommended in Figure 5.
  - Never use a nail, a welding rod, wire, etc., in place of recommended cotter pin.
  - Always ensure cotter pin is bent so as not to interfere with sling operation.
  - Periodically inspect cotter pin for corrosion and general adequacy.

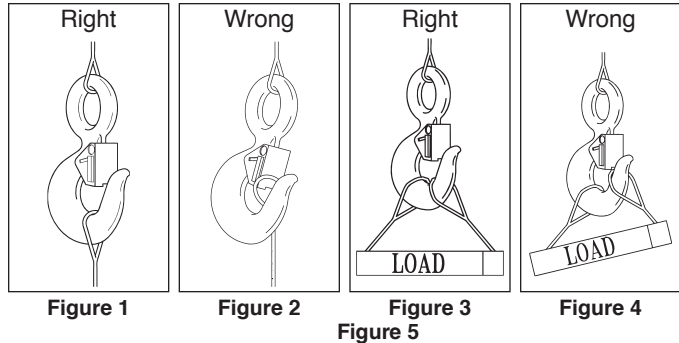

Figure 1

Figure 2

Figure 3

Figure 4

Figure 5

Hook Identification Code	Recommended Cotter Pin Dimensions (mm)	
	Diameter	Length
D	3.19	19.1
F	3.19	19.1
G	3.19	25.4
H	4.76	31.8
I	6.35	38.1
J	23.8	50.8
K	23.8	50.8
L	9.53	76.2
N	9.53	76.2

† The current SS-4055 latch kit and the PL latch will not fit new 319N, 320N, or 322N hooks. They will continue to be offered in both styles to service existing hooks. Important – The new S4320 latch kit will not fit the old 319, 320, or 322 hooks.

### IMPORTANT – Instructions for Assembling S-4320 Latch on Crosby 320N Hooks

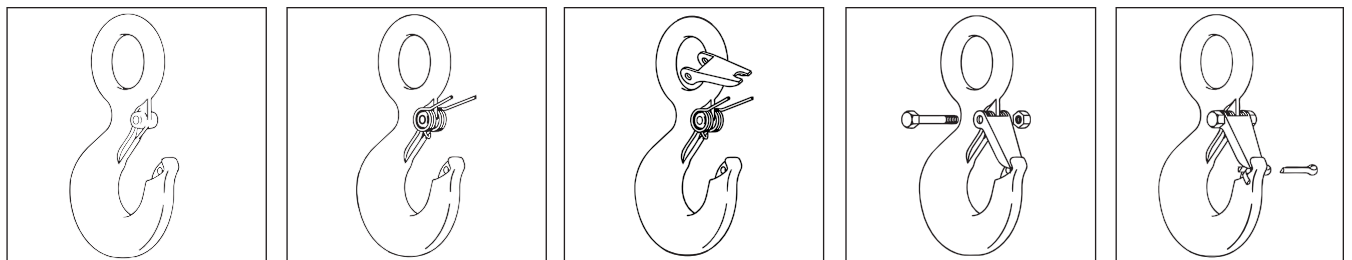

Step 1

Step 2

Step 3

Steps 4, 5, & 6

Step 7 – For Personnel Lifting

1. Place hook at approximately a 45 degree angle with the cam up.

2. Position coils of spring over cam with legs of spring pointing toward point of hook and loop of spring positioned down and lying against the hook.

3. Position latch to side of hook points. Slide latch onto spring legs between lockplate and latch body until latch is partially over hook cam. Then depress latch and spring until latch clears point of hook.

4. Line up holes in latch with hook cam.  
5. Insert bolt through latch, spring, and cam.  
6. Tighten self-locking nut on one end of bolt.

7. With latch in closed position and rigging resting in bowl of hook, insert cotter pin through hook tip and secure by bending prongs.

rev. 1

# Crosby® HOIST HOOKS

## WARNINGS & APPLICATION INSTRUCTIONS

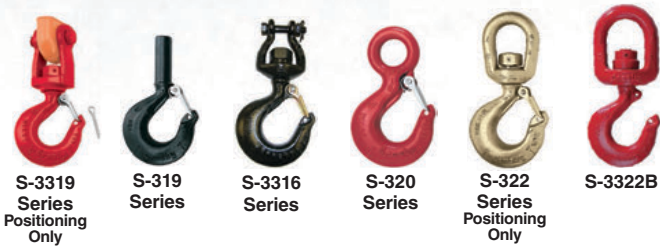

**⚠ WARNING**

- Loads may disengage from hook if proper procedures are not followed.
- A falling load may cause serious injury or death.
- See OSHA Rule 1926.1431(g)(1)(i)(A) and 1926.1501(g)(4)(iv)(B) for personnel hoisting by cranes and derricks, and OSHA Directive CPL 2-136 - Interim Inspection Procedures During Communication Tower Construction Activities. A Crosby 319, 320 or 322 hook with a PL latch attached and secured with a bolt, nut and cotter pin (or toggle pin) may be used for lifting personnel. A Crosby 319N, 320N or 322N hook with an S-4320 latch attached and secured with cotter pin or bolt, nut and pin; or a PL-N latch attached and secured with toggle pin may be used for lifting personnel. A hook with a Crosby SS-4055 latch attached shall NOT be used for personnel lifting.
- See OSHA Directive CPL 2-136 - Crosby does not recommend the placement of lanyards directly into the positive locking Crosby hook when hoisting personnel. Crosby requires that all suspension systems (vertical lifelines / lanyard) shall be gathered at the positive locked load hook by use of a master link, or a bolt-type shackle secured with cotter pin.
- Threads may corrode and/or strip and drop the load.
- Remove securement nut to inspect or to replace S-322, S-3316, and S-3319 bearing washers (2).
- Hook must always support the load. The load must never be supported by the latch.
- Never apply more force than the hook's assigned Working Load Limit (WLL) rating.
- Read and understand these instructions before using hook.

**QUIC-CHECK®** Hoist hooks incorporate markings forged into the product which address two (2) **QUIC-CHECK®** features:

1. **Deformation Indicators** – Two strategically placed marks, one just below the shank or eye and the other on the hook tip, which allows for a **QUIC-CHECK®** measurement to determine if the throat opening has changed, thus indicating abuse or overload. **To check**, use a measuring device (i.e., tape measure) to measure the distance between the marks. The marks should align to either an inch or half-inch increment on the measuring device. If the measurement does not meet criteria, the hook should be inspected further for possible damage.
2. **Angle Indicators** – Indicates the maximum included angle which is allowed between two (2) sling legs in the hook. These indicators also provide the opportunity to approximate other included angles between two sling legs.

### IMPORTANT SAFETY INFORMATION - READ & FOLLOW

A visual periodic inspection for cracks, nicks, wear, gouges and deformation as part of a comprehensive documented inspection program, should be conducted by trained personnel in compliance with the schedule in ANSI B30.10.

- For hooks used in frequent load cycles or pulsating loads, the hook and threads should be periodically inspected by Magnetic Particle or Dye Penetrant. (Note: Some disassembly may be required.)
- Never use a hook whose throat opening has been increased, or whose tip has been bent more than 10 degrees out of plane

from the hook body, or is in any other way distorted or bent. Note: A latch will not work properly on a hook with a bent or worn tip.

- Never use a hook that is worn beyond the limits shown in Figure 1.
- Remove from service any hook with a crack, nick, or gouge. Hooks with a nick or gouge shall be repaired by grinding lengthwise, following the contour of the hook, provided that the reduced dimension is within the limits shown in Figure 1. Contact Crosby Engineering to evaluate any crack.
- Never repair, alter, rework, or reshape a hook by welding, heating, burning, or bending.
- Never side load, back load, or tip load a hook. (Side loading, back loading and tip loading are conditions that damage and reduce the capacity of the hook). (See Figure 2.)
- Eye hooks, shank hooks and swivel hooks are designed to be used with wire rope or chain. Efficiency of assembly may be reduced when used with synthetic material.
- Do not swivel the S-322, S-3316, or S-3319 swivel hooks while supporting a load. These hooks are distinguishable by hex nuts and flat washers.
- The S-3322 swivel hook is designed to rotate under load. The S-3322 is distinguishable from the S-322 by use of a round nut designed to shield bearing.
- The frequency of bearing lubrication on the S-3322 depends upon frequency and period of product use as well as environmental conditions, which are contingent upon the user's good judgment.
- The use of a latch may be mandatory by regulations or safety codes; e.g., OSHA, MSHA, ANSI/ASME B30, Insurance, etc. (Note: When using latches, see instructions in "Understanding The Crosby Group Warnings" for further information.)
- Always make sure the hook supports the load. (See Figure 3). The latch must never support the load (See Figure 4).
- When placing two (2) sling legs in hook, make sure the angle from the vertical to the outermost leg is not greater than 45 degrees, and the included angle between the legs does not exceed 90 degrees\* (See Figure 5).
- See ANSI/ASME B30.10 "Hooks" for additional information.

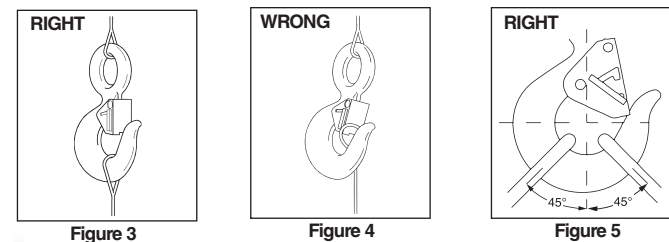
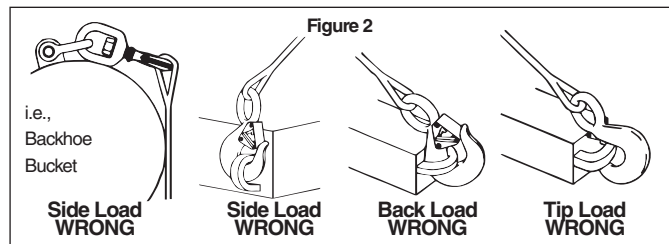
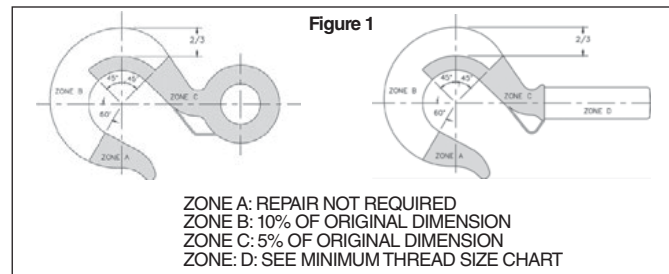

\* For two legged slings with angles greater than 90 degrees, use an intermediate link such as a master link or bolt type shackle to collect the legs of the slings. The intermediate link can be placed over the hook to provide an in-line load on the hook. This approach must also be used when using slings with three or more legs.



# READ AND UNDERSTAND THESE INSTRUCTIONS BEFORE USING HOOKS IMPORTANT – BASIC MACHINING AND THREAD INFORMATION



- Wrong thread and/or shank size can cause stripping and loss of load.
- The maximum diameter is the largest diameter, after cleanup, that could be expected after allowing for straightness, pits, etc.
- All threads must be Class 2 or better.
- The minimum thread length engaged in the nut should not be less than one (1) thread diameter. Install a properly sized retention device to secure the nut to the hook shank after the nut is properly adjusted at assembly. Nut retention devices such as set screws or roll pins are suitable for applications using anti-friction thrust bearings or bronze thrust washers. If the hook is intended for other applications that introduce a higher torque into the nut, a more substantial retaining device may be required.
- Hook shanks are not intended to be swaged on wire rope or rod. See S319SWG for hook designed for swaging.
- Hook shanks are not intended to be drilled (length of shank) and internally threaded.

- Crosby can not assume responsibility for, (A) the quality of machining, (B) the type of application, or (C) the means of attachment to the power source or load.
- Consult the Crosby Hook Identification & Working Load Limit Chart (See below) for the minimum thread size for assigned Working Load Limits (WLL).†
- Remove from service any Hook which has threads corroded more than 20% of the nut engaged length.

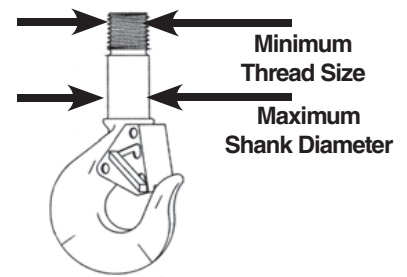

## CROSBY HOOK IDENTIFICATION & WORKING LOAD LIMIT CHART†

Hook Identification			Working Load Limit (t)					Maximum Shank Diameter after Machining (mm)	Minimum Thread Size	
319-C 319-CN 320-C 320-CN 322-C 322-CN	319-AN 320-AN 322-A 322-AN 3319 3322B	319-BN	319-C 319-CN 320-C 320-CN 322-C 322-CN	319-A 319-AN 320-A 320-AN 322-A 322-AN S-3322B	319-BN	S-3319	S-3316		319-C 319-CN (Carbon)	319-A 319-AN (Alloy) 319-BN (Bronze)
DC	DA	DB	.75	1	.5	—	—	13.4	1/2 - 13unc	1/2 - 13 unc
FC	FA	FB	1	1.5	.6	—	.45	15.7	5/8 - 11unc	5/8 - 11 unc
GC	GA	GB	1.5	2	1	—	—	16.8	5/8 - 11unc	5/8 - 11 unc
HC	HA	HB	2	3	1.4	1.63	.91	20.6	3/4 - 10unc	3/4 - 10 unc
IC	IA	IB	3	*4.5/5	2.0	2.5	—	26.2	7/8 - 9unc	7/8 - 9 unc
JC	JA	JB	5	7	3.5	4.5	—	32.3	1-1/8 - 7unc	1-1/8 - 7 unc
KC	KA	KB	7.5	11	5.0	—	—	38.6	1-1/4 - 7unc	1-3/8 - 6 unc
LC	LA	LB	10	15	6.5	—	—	44.5	1-5/8 - 8un	1-5/8 - 8 un
NC	NA	NB	15	22	10	—	—	50.8	2 - 8un	2 - 8 un
OC	OA	—	20	30	—	—	—	63.5	2-1/4 - 8un	2-1/4 - 8 un
PC	PA	—	25	37	—	—	—	89.0	2-3/4 - 8un	2-3/4 - 8 un
SC	SA	—	30	45	—	—	—	89.0	3 - 8un	3 - 8 un
TC	TA	—	40	60	—	—	—	102	3-1/4 - 8un	3-1/2 - 8 un
UC	UA	—	50	75	—	—	—	114	3-3/4 - 8un	4 - 4 unc
—	WA	—	—	100	—	—	—	155	—	4-1/2 - 8 un
—	XA	—	—	150	—	—	—	162	—	5-1/2 - 8 un
—	YA	—	—	200	—	—	—	178	—	6-1/4 - 8 un
—	ZA	—	—	300	—	—	—	219	—	7-1/2 - 8 un

\* 319AN, 320-AN, 3322 and 322AN are rated at 5 tons.

† Working Load Limit - The maximum mass or force which the product is authorized to support in general service when the pull is applied in-line, unless noted otherwise, with respect to the centerline of the product. This term is used interchangeably with the following terms: 1. WLL, 2. Rated Load Value, 3. SWL, 4. Safe Working Load, 5. Resultant Safe Working Load.

## Warning and Application Instructions For Crosby® Hook Latch Kit

### IMPORTANT SAFETY INFORMATION - READ & FOLLOW

- Always inspect hook and latch before using.
- Never use a latch that is distorted or bent.
- Always make sure spring will force the latch against the tip of the hook.
- Always make sure hook supports the load. The latch must never support the load. (See Figures 1 & 2)
- When placing two (2) sling legs in hooks, make sure the angle between the legs is less the 90° and if the hook or load is tilted, nothing bears against the bottom of this latch. (See Figures 3 & 4)
- Latches are intended to retain loose sling or devices under slack conditions.
- Latches are not intended to be an anti-fouling device.

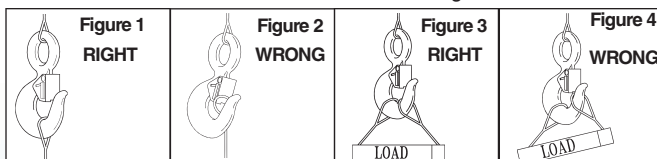

### ⚠ WARNING

- Loads may disengage from hook if proper procedures are not followed.
- A falling load may cause serious injury or death.
- See OSHA Rule 1926.1431(g)(1)(i)(A) and 1926.1501(g)(4)(iv)(B) for personnel hoisting for cranes and derricks. Only a Crosby or McKissick hook with a PL Latch attached and secured with bolt, nut and cotter (or Crosby Toggle Pin) or a Crosby hook with a S-4320 Latch attached and secured with a cotter pin, or a Crosby SHUR-LOC® hook in the locked position may be used for any personnel hoisting. A hook with a Crosby SS-4055 latch attached shall NOT be used for personnel lifting.
- Hook must always support the load. The load must never be supported by the latch.
- DO NOT use this latch in applications requiring non-sparking.
- Read and understand these instructions before using hook and latch.

HOOKS & SWIVELS

# McKissick® HOIST HOOKS

## WARNINGS & APPLICATION INSTRUCTIONS



S-320 Series



S-319 Series



S-322 Series  
Positioning  
Only



S-332B Series

### ⚠ WARNING

- Loads may disengage from hook if proper procedures are not followed.
- A falling load may cause serious injury or death.
- See OSHA Rule 1926.1431(g)(1)(i)(A) and 1926.1501(g)(4)(iv)(B) for personnel hoisting by cranes and derricks, and OSHA Directive CPL 2-1.36 - Interim Inspection Procedures During Communication Tower Construction Activities. A Crosby 319, 320 or 322 hook with a PL latch attached and secured with a bolt, nut and cotter pin (or toggle pin) may be used for lifting personnel. A Crosby 319N, 320N or 322N hook with an S-4320 latch attached and secured with cotter pin or bolt, nut and pin; or a PL-N latch attached and secured with toggle pin may be used for lifting personnel. A hook with a Crosby SS-4055 latch attached shall NOT be used for personnel lifting.
- See OSHA Directive CPL 2-1.36 - Crosby does not recommend the placement of lanyards directly into the positive locking Crosby hook when hoisting personnel. Crosby requires that all suspension systems (vertical lifelines / lanyard) shall be gathered at the positive locked load hook by use of a master link, or a bolt-type shackle secured with cotter pin.
- Threads or Split-Nut may corrode and/or strip and drop the load.
- Remove securement nut to inspect or to replace S-322 and S-3319 bearing washers (2).
- Hook must always support the load. The load must never be supported by the latch.
- Never apply more force than the hook's assigned Working Load Limit (WLL) rating.
- Read and understand these instructions before using hook.

**QUIC-CHECK®** Hoist hooks incorporate markings forged into the product which address two (2) QUIC-CHECK® features:

**Deformation Indicators** - Two strategically placed marks, one just below the shank or eye and the other on the hook tip, which allows for a QUIC-CHECK® measurement to determine if the throat opening has changed, thus indicating abuse or overload.

**To check**, use a measuring device (i.e., tape measure) to measure the distance between the marks. The marks should align to either an inch or half-inch increment on the measuring device. If the measurement does not meet criteria, the hook should be inspected further for possible damage.

**Angle Indicators** - Indicates the maximum included angle which is allowed between two (2) sling legs in the hook. These indicators also provide the opportunity to approximate other included angles between two sling legs.



### IMPORTANT SAFETY INFORMATION - READ & FOLLOW

- A visual periodic inspection for cracks, nicks, wear, gouges and deformation as part of a comprehensive documented inspection program, should be conducted by trained personnel in compliance with the schedule in ANSI B30.10.
- For hooks used in frequent load cycles or pulsating loads, the hook and threads should be periodically inspected by Magnetic Particle or Dye Penetrant. (Note: Some disassembly may be required.)
- Never use a hook whose throat opening has been increased, or whose tip has been bent more than 10 degrees out of plane from the hook body, or is in any other way distorted or bent. **Note: A latch will**

**not work properly on a hook with a bent or worn tip.**

- Never use a hook that is worn beyond the limits shown in Figure 1.
- Remove from service any hook with a crack, nick, or gouge. Hooks with a nick or gouge shall be repaired by grinding lengthwise, following the contour of the hook, provided that the reduced dimension is within the limits shown in Figure 1. Contact Crosby Engineering to evaluate any crack.
- Remove from service any hook which has threads corroded more than 20% of the nut engagement length.
- Never repair, alter, rework, or reshape a hook by welding, heating, burning, or bending.
- Never side load, back load, or tip load a hook. (Side loading, back loading and tip loading are conditions that damage and reduce the capacity of the hook). (See Figure 2.)
- Eye hooks, shank hooks and swivel hooks are designed to be used with wire rope or chain. Efficiency of assembly may be reduced when used with synthetic material.
- Do not swivel the S-322 or S-3319 swivel hooks while supporting a load. These hooks are distinguishable by hex nuts and flat washers.
- The S-3322 swivel hook is designed to rotate under load. The S-3322 is distinguishable from the S-322 by use of a round nut designed to shield bearing.
- The frequency of bearing lubrication on the S-3322 depends upon frequency and period of product use as well as environmental conditions, which are contingent upon the user's good judgment.
- The use of a latch may be mandatory by regulations or safety codes; e.g., OSHA, MSHA, ASME B30, Insurance, etc.. (Note: When using latches, see instructions in "Understanding: The Crosby Group Warnings" for further information.)
- Always make sure the hook supports the load. (See Figure 3). The latch must never support the load (See Figure 4).
- When placing two (2) sling legs in hook, make sure the angle from the vertical to the outermost leg is not greater than 45 degrees, and the included angle between the legs does not exceed 90 degrees\* (See Figure 5).
- Reference Crosby's Hoist Hook Warning and Application Information for basic machining and minimum thread size.
- See ASME B30.10 "Hooks" for additional information.

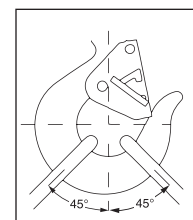
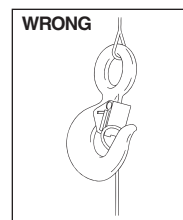
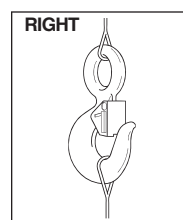
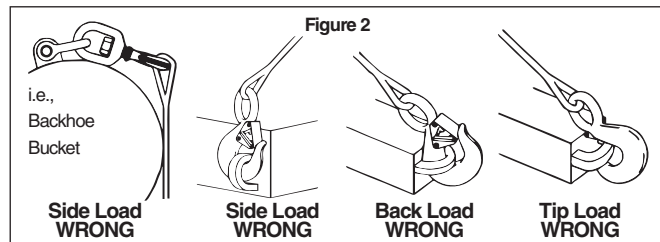
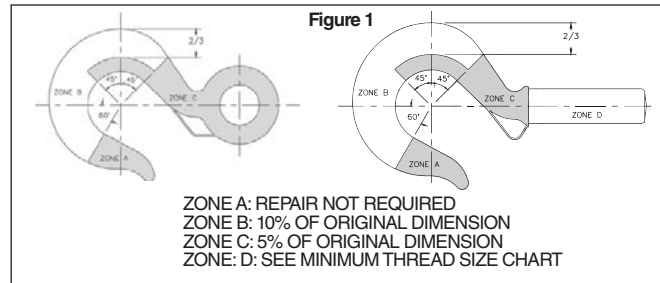

\* For two legged slings with angles greater than 90 degrees, use an intermediate link such as a master link or bolt type shackle to collect the legs of the slings. The intermediate link can be placed over the hook to provide an in-line load on the hook. This approach must also be used when using slings with three or more legs.





### Removal of Split-Nut assembly (Reference Figure A):

- Remove vinyl cover.
- Remove spring retaining ring.
- Slide steel keeper ring off split nuts **▲ (CAUTION: Removal of keeper ring will allow split nut halves to fall from hook shank).**
- Remove split nut halves.

### Inspection of split nut assembly and hook shank interface area (Reference Figure B):

- Inspect hook shank and split nut for signs of deformation on and adjacent to the load bearing surfaces.
- Inspect outside corner of hook shank load bearing surface to verify the corner is sharp.
- Verify retaining ring groove will allow proper seating of the retaining ring.
- Inspect retaining ring for corrosion or deformation. Remove from service any retaining ring that has excessive corrosion or is deformed.
- Use fine grit emery or crocus cloth to remove any corrosion from machined hook shank and split nut assembly.
- Follow inspection recommendations listed in this document under IMPORTANT SAFETY INFORMATION.
- If corrosion is present on the nut / shank interface area and deterioration or degradation of the metal components is evident, further inspection is required.
  - The use of a feeler gauge is required to properly measure the maximum allowable gap width between the split nut inside diameters and shank outside diameters.
  - With one split nut half seated against the hook shank, push the nut to one side and measure the maximum gaps as shown in Figure B. The hook should be measured in four places, 90-degrees apart.
  - Repeat above inspection procedure with other half of split nut.
  - Remove from service any hook and split nut assembly that exhibits a gap greater than 0.030"

### Installation of split nut assembly (Reference Figure A):

- Coat hook shank and inside of split nut with an anti-seize compound or heavy grease.
- Install split nut halves onto shank. The flanged bottom of the split nut should be closest to the hook shoulder.

- Slide steel keeper ring over split nut halves. Verify the split nut halves properly seat against the load bearing surface of the hook shank and the steel keeper ring seats against the flange of the split nut.
- Install retaining ring onto split nut halves. Verify the retaining ring seats properly in the retaining ring groove on the outside diameter of the split nut assembly.
- Install vinyl cover over split nut and hook shank assembly.
- Verify all fasteners are correctly installed.
- Always use Genuine Crosby replacement parts.

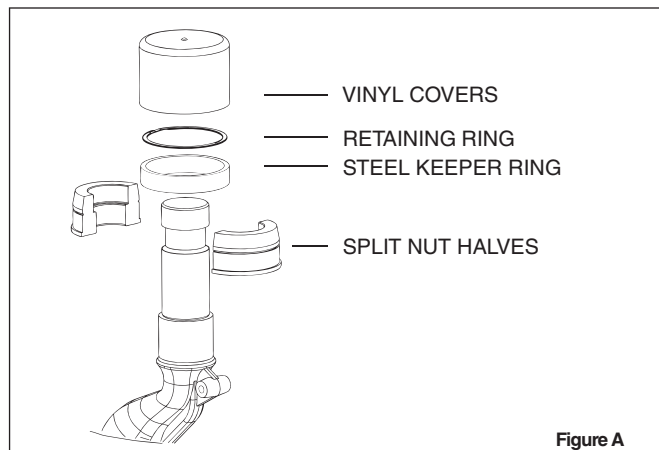

Figure A

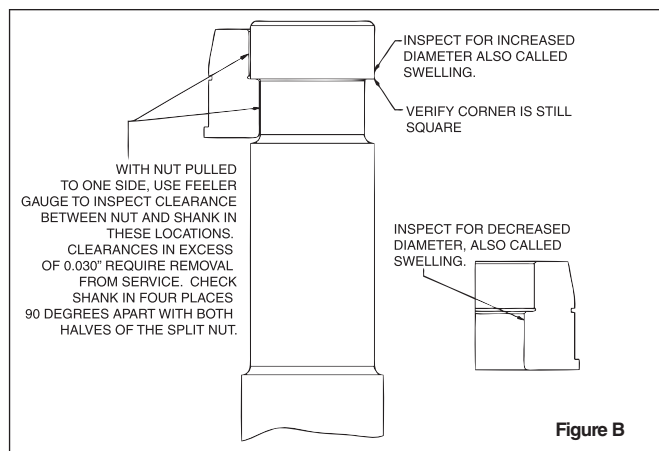
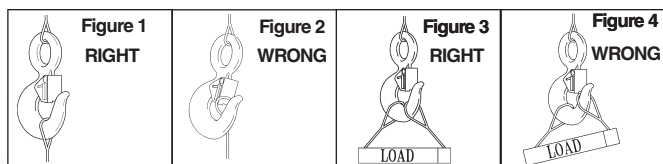

Figure B

## Warning and Application Instructions For McKISSICK® Hook Latch Kit

### IMPORTANT SAFETY INFORMATION - READ & FOLLOW

- Always inspect hook and latch before using.
- Never use a latch that is distorted or bent.
- Always make sure spring will force the latch against the tip of the hook.
- Always make sure hook supports the load. The latch must never support the load. (See Figures 1 & 2)
- When placing two (2) sling legs in hooks, make sure the angle between the legs is less the 90° and if the hook or load is tilted, nothing bears against the bottom of this latch. (See Figures 3 & 4)
- Latches are intended to retain loose sling or devices under slack conditions.
- Latches are not intended to be an anti-fouling device.



**▲ WARNING**

- Loads may disengage from hook if proper procedures are not followed.
- A falling load may cause serious injury or death.
- See OSHA Rule 1926.1431(g)(1)(i)(A) and 1926.1501(g)(4)(iv) (B) for personnel hoisting for cranes and derricks. Only a Crosby or McKissick hook with a PL Latch attached and secured with bolt, nut and cotter (or Crosby Toggle Pin) or a Crosby hook with a S-4320 Latch attached and secured with a cotter pin, or a Crosby SHUR-LOC® hook in the locked position may be used for any personnel hoisting. A hook with a Crosby SS-4055 latch attached shall NOT be used for personnel lifting.
- Hook must always support the load. The load must never be supported by the latch.
- Do not use this latch in applications requiring non-sparking.
- Read and understand these instructions before using hook and latch.

HOOKS & SWIVELS

# Crosby® / BULLARD® GOLDEN GATE® HOOKS

## WARNINGS & APPLICATION INSTRUCTIONS

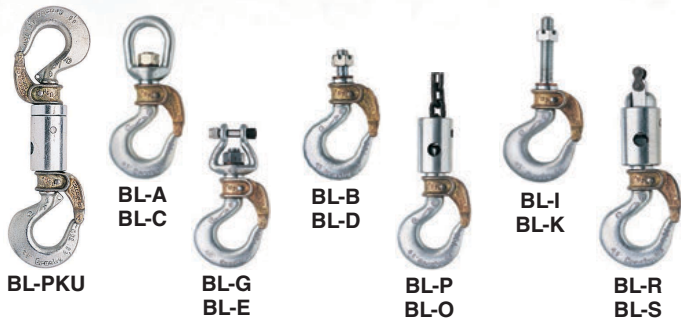

**QUIC-CHECK®** Hoist Hooks incorporate markings forged into the product which address two (2) **QUIC-CHECK®** features: **Deformation Indicators** – Two strategically placed marks, one just below the shank or eye and the other on the hook tip, which allows for a **QUIC-CHECK®** measurement to determine if the throat opening has changed, thus indicating abuse or overload.

**To check**, use a measuring device (i.e., tape measure) to measure the distance between the marks. The marks should align to either an inch or half-inch increment on the measuring device. If the measurement does not meet criteria, the hook should be inspected further for possible damage.

**Angle Indicators** – Indicates the maximum included angle which is allowed between two (2) sling legs in the hook. These indicators also provide the opportunity to approximate other included angles between two sling legs.



### IMPORTANT SAFETY INFORMATION - READ & FOLLOW

- A visual periodic inspection for cracks, nicks, wear, gouges and deformation as part of a comprehensive documented inspection program, should be conducted by trained personnel in compliance with the schedule in ANSI B 30.10.
- For hooks used in frequent load cycles or pulsating loads, the hook and threads should be periodically inspected by Magnetic Particle or Dye Penetrant. (Note: Some disassembly may be required.)
- See WARNING box and Figure 6 for special instructions for securing the nut to the shank at assembly.
- Never use a hook whose throat opening has been increased, or whose tip has been bent more than 10 degrees out of plane from the hook body, or is in any other way distorted or bent. **Note: A gate will not work properly on a hook with a bent or worn tip.**
- Manual - closing gates must be completely closed for the lock to work.
- Never use a hook that is worn beyond the limits shown in Figure 1.
- Remove from service any hook with a crack, nick, or gouge. Hooks with a nick or gouge shall be repaired by grinding lengthwise, following the contour of the hook, provided that the reduced dimension is within the limits shown in Figure 1. Contact Crosby Engineering to evaluate any crack.
- Never repair, alter, rework, or reshape a hook by welding, heating, burning, or bending.
- Never side load, back load, or tip load a hook. Side loading, back loading and tip loading are conditions that damage and reduce the capacity of the hook. (See Figure 2).
- Eye hooks, shank hooks and swivel hooks are designed to be used with wire rope or chain. Efficiency of assembly may be reduced when used with synthetic material.

### WARNING

- Loads may disengage from hook if proper procedures are not followed.
- A falling load may cause serious injury or death.
- Before using, inspect the hook and gate daily to ensure it is in proper operating condition.
- Failure to properly insert the pin could result in the load falling.
- All Golden Gate® Hooks with threaded shanks require a pin to secure the nut to the shank. This pin prevents the nut from backing off or unscrewing from the threads and causing the load to drop.
- If the pin and nut are removed from the shank to replace any hook components, the pin and nut must be installed before use.
 

**NOTE: 1.** If a solid pin was used, the old pin “must” be discarded and a new pin inserted to secure the nut to the shank.

**2.** If a spring pin (coil type) was used, it may be reused provided that the spring pin and / or the drill hole was not damaged.
- The gate is not a load-bearing device. Do not allow the sling or other loads to bear against the gate.
- Threads may corrode and / or strip and drop the load.
- Hands, fingers and body should be kept away from the hook and load whenever possible.
- Never apply more force than the hook’s assigned Working Load Limit (WLL) rating.
- Read and understand these instructions before using.

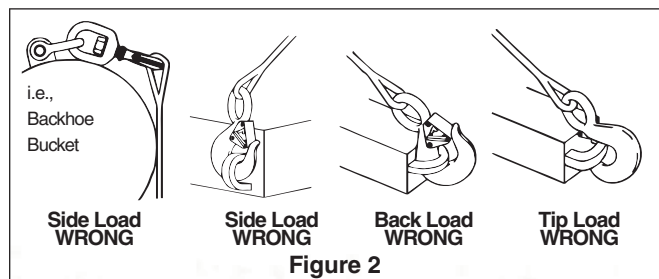
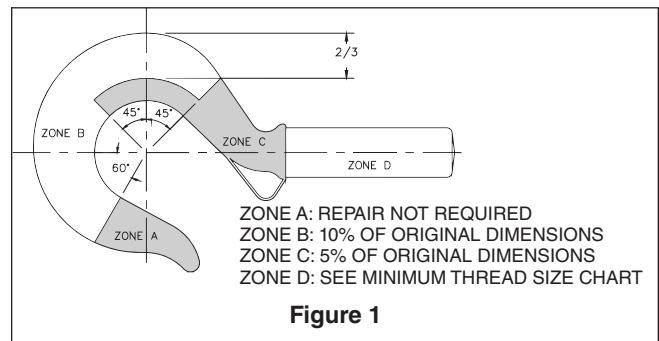





- The use of a latch may be mandatory by regulations or safety codes: e.g., OSHA, MSHA, ANSI/ASME B30, Insurance etc.
- Always make sure the hook supports the load (See Figure 3). The gate must never support the load (See Figure 4).
- When placing two (2) sling legs in hook, make sure the angle from the vertical to the outermost leg is not greater than 45 degrees, and the included angle between the legs does not exceed 90 degrees<sup>†</sup> (See Figure 5).
- See ANSI/ASME B30.10 “Hooks” for additional information.
- If any of the following conditions exist, remove hook from service immediately and repair with genuine Crosby / Bullard Golden Gate<sup>®</sup> hook parts or replace the hook.
  - The gate does not lock in the closed position.
  - The gate is worn, deformed, inoperative, or fails to bridge the hook throat opening.
  - Load pins or bolts in the chain connectors are worn or bent.
- When hook is used to support a hoist, the weight of the hoist must be deducted from the assigned hook Working Load Limit.
- The rated capacity of chain connector hook assemblies must equal or exceed the capacity of the hoist.

<sup>†</sup> For two legged slings with angles greater than 90°, use an intermediate link such as a master link or bolt type shackle to collect the legs of the slings. The intermediate link can then be placed over the hook to provide an in-line load on the hook. This approach must also be used when using slings with three or more legs.

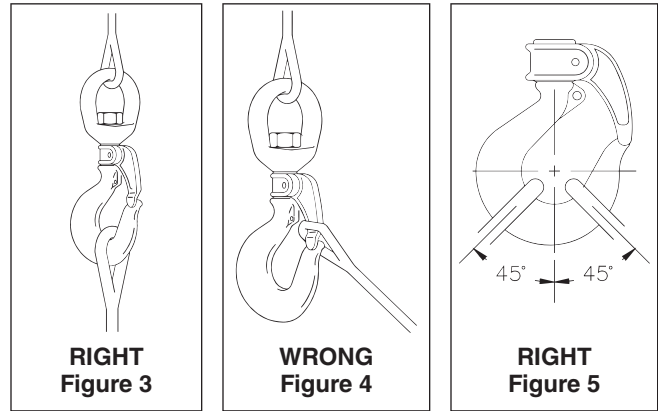

### Important – Basic Machining and Thread Information – Read and Follow

- Wrong thread and/or shank size can cause stripping and loss of load.
- The maximum diameter is the largest diameter that will fit into the gate.
- All threads must be Class 2 or better.
- The minimum thread length engaged in the nut should not be less than one (1) thread diameter.
- All nuts must be secured to the shank by cross drilling the nut and threaded shank and inserting the appropriate coil type spring pin (See WARNING box and Figure 6 for special instructions).
- Coil type spring pin must be as long as the distance across the nut flats or diameter (See Figure 6).
- Consult the Crosby / Bullard Golden Gate<sup>®</sup> Hook Identification and Working Load Limit Chart (See below) for the coil type spring pin diameter.
- Remove any hook from service that requires a larger coil type spring than that shown in the chart below.

- Hook shanks are not intended to be swaged on wire rope or rod.
- Hook shanks are not intended to be drilled and internally threaded.
- Crosby cannot assume responsibility for:
  - (A) the quality of machining,
  - (B) the type of application, or
  - (C) the means of attachment to the power source or load.
- Consult the Crosby/Bullard Golden Gate<sup>®</sup> Hook Identification & Working Load Limit Chart (below) for the minimum thread size for assigned Working Load Limits (WLL). +
- Remove from service any hook which has threads corroded more than 20% of the nut engaged length.

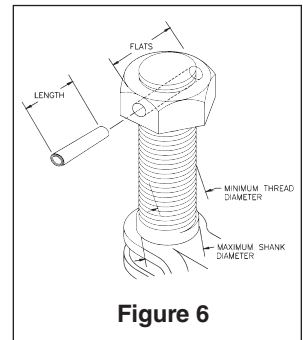

### Crosby / Bullard Golden Gate<sup>®</sup> Hook Identification and Working Load Limit Chart

Hook / Gate Size	Working Load Limit ** + (t)	Maximum Shank Diameter (mm)	Minimum Thread Size	Spring* Pin Size (mm)	Drilled Hole Size (mm)	Hook / Gate Size	Working Load Limit (t)	Maximum Shank Diameter (mm)	Minimum Thread Size	Spring* Pin Size (mm)	Drilled Hole Size (mm)
1	.45	—	—	—	—	11	8.35	38	1-1/2 - 6 UNC	7.9	7.8/8.10
2	.90	12.70	1/2 - 13 UNC	3.2	3.15/3.30	12	11.15	41.2	1-5/8 - 5-1/2 UNC	7.9	7.8/8.10
3	1.27	14.20	9/16 - 12 UNC	3.2	3.15/3.30	13	13.6	44.4	1-3/4 - 5 UNC	9.5	9.40/9.7
4	1.54	15.80	5/8 - 11 UNC	3.2	3.15/3.30	14	16.8	50.7	2 - 4-1/2 UNC	9.5	9.40/9.7
5	2.09	19.00	3/4 - 10 UNC	4.0	3.94/4.05	16	22.4	69.8	2-3/4 - 4 UNC	12.7	12.5/12.95
6	3.63	22.20	7/8 - 9 UNC	4.75	4.70/4.90	16-A	29.9	69.8	2-3/4 - 4 UNC	12.7	12.5/12.95
7	3.81	25.30	1 - 8 UNC	4.75	4.70/4.90	17	44.9	101.5	4 - 4 UNC	19.1	18.9/19.30
8	5.00	28.50	1-1/8 - 7 UNC	6.35	6.25/6.50	17-A	59.9	101.5	4 - 4 UNC	19.1	18.9/19.30
9	6.53	31.70	1-1/4 - 7 UNC	6.35	6.25/6.50	—	—	—	—	—	—

\* Heavy Duty Coil Type Spring Pin.

\*\* Minimum ultimate strength is 4 times the Working Load Limit.

+ Working Load Limit - The maximum mass or force which the product is authorized to support in general service when the pull is applied in-line, unless noted otherwise with respect to centerline of the product. This term is used interchangeably with the following terms: 1. WLL, 2. Rated Load Value, 3. SWL, 4. Safe Working Load, 5. Resultant Safe Working Load. Ultimate Load is 4 times the Working Load.

# Crosby® WELD-ON HOOKS

## WARNINGS & APPLICATION INSTRUCTIONS



BH-313

### IMPORTANT SAFETY INFORMATION - READ & FOLLOW

- Weld-On hooks are to only be welded to a structure, equipment or machinery in an area (load point) approved by the original equipment manufacturer. (Some manufacturers may not approve the modification of their product.)
- For hydraulic excavator lift capacity rating, refer to SAE standard J1097.
- A visual periodic inspection for cracks, nicks, wear, gouges and deformation as part of a comprehensive documented inspection program, should be conducted by trained personnel.
- A visual periodic inspection of the weld should be performed. Check the weld visually, or use a suitable NDE method if required.
- As excavator buckets are not specifically designed for constant use with excavator hooks, we recommend regular and very thorough inspection of the excavator bucket welding area to ensure no distortion has been made to the work area.
- Never use a hook whose throat opening has been increased, or whose tip has been bent more than 10 degrees out of plane from the hook body, or is in any other way distorted or bent.

**Note: A latch will not work properly on a hook with a bent or worn tip.**

- Never use a hook that is worn beyond the limits shown in Figure 1.
- Remove from service any hook with a crack, nick, or gouge. Hooks with a nick or gouge shall be repaired by grinding lengthwise, following the contour of the hook, provided that the reduced dimension is within the limits shown in Figure 1. Contact Crosby Engineering to evaluate any crack.
- Never repair, alter, rework, or reshape a hook by welding, heating, burning, or bending.
- Always make sure the hook supports the load. The load is to be applied within the range shown in Figure 2. The latch must never support the load (See Figure 3).
- Never side load (See Figure 4), or tip load (See Figure 5) a hook.
- The use of a latch may be mandatory by regulations or safety codes; e.g., OSHA, MSHA, ANSI/ASME B30, Insurance, etc. (Note: When using latches, see instructions in "Understanding: The Crosby Group Warnings" for further information.)
- Ensure latch functions properly. Use only genuine Crosby replacement parts.
- Never attach more than one sling directly in hook. For collecting two or more slings to the hook, use proper hardware.
- See ANSI/ASME B30.10 "Hooks" for additional information.

### ⚠ WARNING

- Loads may disengage from hook if proper procedures are not followed.
- A falling load may cause serious injury or death.
- Hook must always support the load. The load must never be supported by the latch.
- Never apply more force than the hook's assigned Working Load Limit (WLL) rating.
- Do not use Crosby weld-on hook for personnel hoisting. See OSHA Rule 1926.1431(g)(1)(i)(A) and 1926.1501(g)(4)(iv)(B).
- Read and understand these instructions before welding on, or using hook.

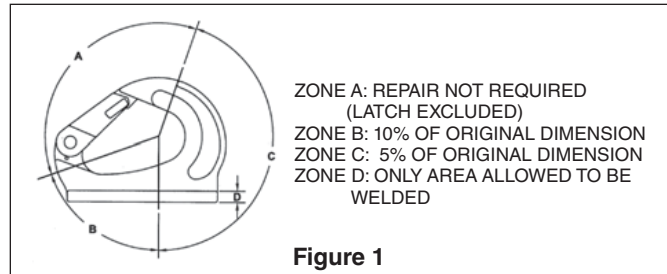

Figure 1

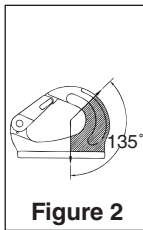
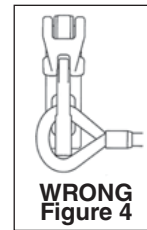

Figure 2



WRONG  
Figure 3



WRONG  
Figure 4

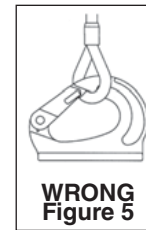

WRONG  
Figure 5

- The strength of the weld-on hook depends upon the method of attachment. Extreme care must be used in choice of support as well as during the attachment process.
- The support structure that the hook is attached to must be of suitable size, composition and quality to support the anticipated loads of all operating positions. The required support structure material thickness for a given application is dependent on variables such as unsupported length and material strength, and should be determined by a qualified individual. Minimum plate thickness required to support the welds are shown in Table 1.

Working Load Limit (t)	Minimum Plate Thickness (in.)	Minimum Fillet Size All Around (in.)	Minimum Plate Thickness (mm)	Minimum Fillet Size All Around (mm)
1	3/16	3/16	5	5
2	1/4	1/4	6	6
3	5/16	5/16	8	8
4	5/16	5/16	8	8
5	3/8	3/8	10	10
8	1/2	1/2	13	13
10	1/2	1/2	13	13





- Position the hook to ensure that the load is applied in the plane of the hook, and the load is supported by the hook in all operating positions. Ensure that the hook does not interfere with the operation of other mechanisms or cause pinch points.
- Ensure that the maximum gap between hook base and support does not exceed 1/8". Modify the support structure if required to reduce gap.
- When welding hook to carbon or low alloy steels (less than .40% carbon), the following welding recommendations are to be followed. For welding hook to other grades of steel, a qualified weld procedure must be developed. Crosby hook material is AISI 8622 modified.
- Welding is to be performed by a qualified welder using qualified procedure in accordance with American Welding Society (AWS), and/or American Society of Mechanical Engineers (ASME) requirements.
- Welding electrode to be in accordance with AWS A5.4 E-312-16. Observe the electrode manufacturer's recommendations.
- Welding preheat range outlined below.
  - Minimum preheat temperature: 212F (100C)
  - Maximum temperature: 716F (380C)
- Before welding, the surface to be welded on, including the hook and support structure, must be clean and free from rust, grease and paint.
- Fillet weld leg size should be of minimum shown in Table 1, page 150. Weld profiles to be in accordance with AWS. Weld size is measured by length of leg.
- Welding should be carried out completely around base in a minimum of two passes to ensure adequate root penetration at the base of the hook.
- Do not rapidly cool the weld.
- After welding, a visual inspection of the weld should be performed prior to painting.
- No cracks, pitting, inclusions, notches or undercuts are allowed. If doubt exists, use a suitable NDE method, such as Magnetic Particle or Liquid Penetrant to verify.
- If repair is required on weld, grind out defect and re-weld using original qualified procedure.
- After welding, the assembly should be proof tested before putting into service.

### Important – Instructions for Assembling S-4313 Latch on BH-313 Weld-On Hook

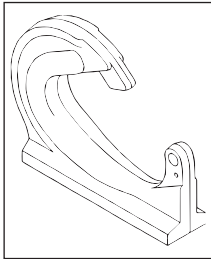

#### Step 1

1. Place hook flat on work surface as shown.

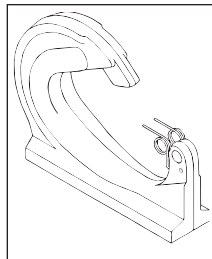

#### Step 2

#### Hook sizes 1 to 3 tons

2. Position coils of spring over hook cam, with legs of spring pointing towards hook tip and coil of spring positioned down as shown.

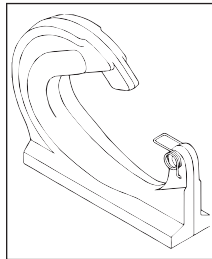

#### Step 2A

#### Hook sizes 4 to 10 tons

2A. Spread legs of spring and place into drilled hole. Position coils of spring over hook cam, with end of spring pointing toward hook tip as shown.

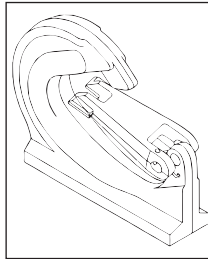

#### Step 3

3. Position latch over spring, aligning latch ears and spring coil. On pin hole side of latch, insert non-grooved end of latch pin through hole in latch and through spring until contact is made with hook body (a small punch may be required for proper alignment).

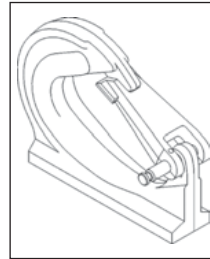

#### Step 4

4. Align holes in latch with holes in cam of hook. Continue pushing the pin through hook, spring and latch.

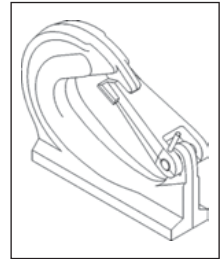

#### Step 5

5. Insert roll-pin into latch, driving it in with a hammer, while ensuring that latch pin groove is in alignment.

# Crosby® HOOK LATCH KIT

## WARNINGS & APPLICATION INSTRUCTIONS

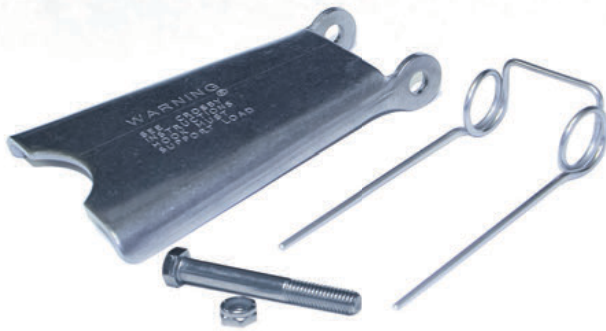

SS-4055

### IMPORTANT SAFETY INFORMATION - READ & FOLLOW

- Always inspect hook and latch before using.
- Never use a latch that is distorted or bent.
- Always make sure spring will force the latch against the tip of the hook.
- Always make sure hook supports the load. The latch must never support the load. (See Figures 1 & 2)
- When placing two (2) sling legs in hook, make sure the angle between legs is small enough and the legs are not tilted so that nothing bears against the bottom of the latch. (See Figures 3 & 4)
- Latches are intended to retain loose sling or devices under slack conditions.
- Latches are not intended to be an anti-fouling device.

### WARNING

- Loads may disengage from hook if proper procedures are not followed.
- A falling load may cause serious injury or death.
- See OSHA Rule 1926.1431(g)(1)(i)(A) and 1962.1501(g)(4)(iv)(B) A hook and this style latch must not be used for lifting personnel.
- Hook must always support the load. The load must never be supported by the latch.
- Read and understand these instructions before using hook and latch.

RIGHT



Figure 1

WRONG



Figure 2

RIGHT



Figure 3

WRONG

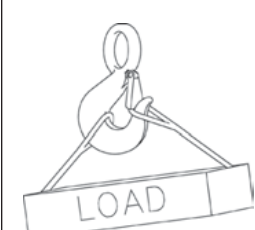

Figure 4

### IMPORTANT – Instructions for Assembling Model SS-4055 Latch on Crosby Hooks



Step 1

1. Place hook at approximately a 45 degree angle with the cam up.

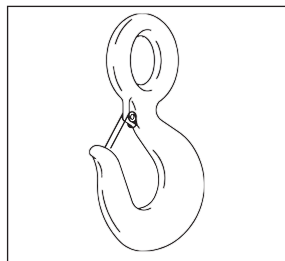

Step 2

2. Position coils of spring over cam with tines of spring pointing toward point of hook and loop of spring positioned down and lying against the hook.



Step 3

3. Position latch over tines of spring with ears partially over hook cam. Swing latch to one side of hook, point and depress latch and spring until latch clears point of hook.

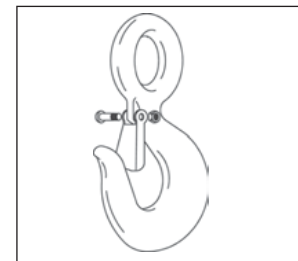

Steps 4, 5, & 6

4. Line up holes in latch with hook cam.  
5. Insert bolt through latch, spring, and cam.  
6. Tighten self-locking nut on one end of bolt.



# Crosby® MODEL PL HOOK LATCH KIT

## WARNINGS & APPLICATION INSTRUCTIONS

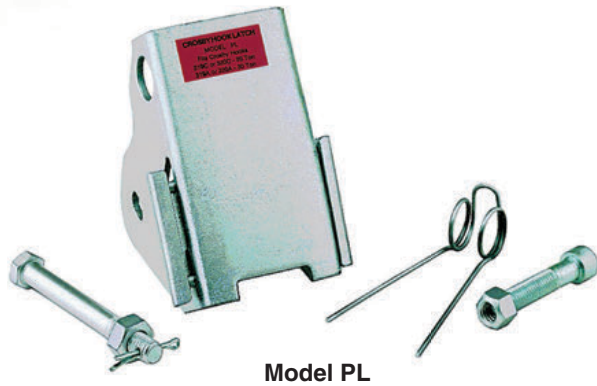

### ⚠ WARNING

- Loads may disengage from hook if proper procedures are not followed.
- A falling load may cause serious injury or death.
- See OSHA Rule 1926.1431(g)(1)(i)(A) and 1926.1501(g)(4)(iv)(B) for Personnel Hoisting by Cranes or Derricks. A Crosby or McKissick Hook with a positive Locked PL or S-4320 Latch may be used to Lift Personnel.
- Hook must always support the load. The load must never be supported by the latch.
- DO NOT use this latch in applications requiring non-sparking.
- Read and understand these instructions before using hook and latch.

### IMPORTANT SAFETY INFORMATION - READ & FOLLOW

(Pat. USA & Canada)

- Always inspect hook and latch before using.
- Never use a latch that is distorted or bent.
- Always make sure spring will force the latch against the tip of the hook.
- Always make sure hook supports the load. The latch must never support the load. (See Figures 1 & 2)
- When placing two (2) sling legs in hook, make sure the angle between the legs is less than 90° and if the hook or load is tilted, nothing bears against the bottom of this latch. (See Figures 3 & 4)
- Latches are intended to retain loose sling or devices under slack conditions.
- Latches are not intended to be an anti-fouling device.

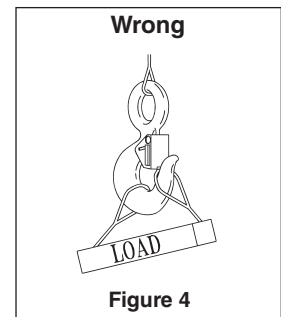
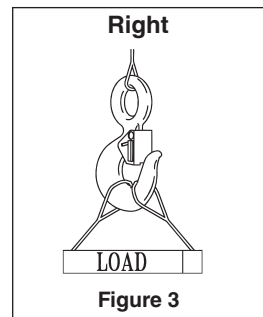
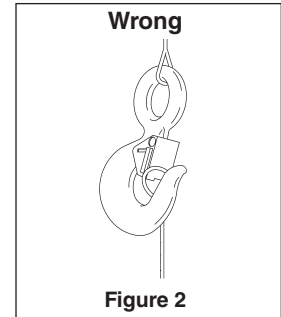
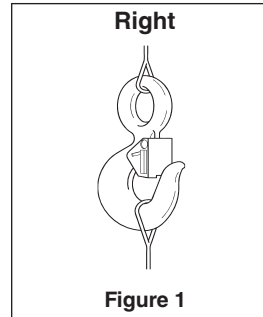

### IMPORTANT - Instructions for Assembling Model PL Latch on Crosby or McKissick Hooks



**Step 1**

1. Place hook at approximately a 45 degree angle with the cam up.

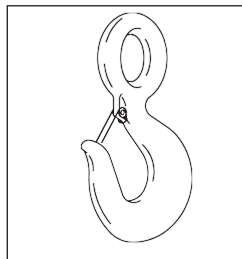

**Step 2**

2. Position coils of spring over cam with legs of spring pointing toward point of hook and loop of spring positioned down and lying against the hook.

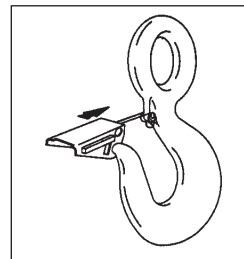

**Step 3**

3. Position latch to side of hook points. Slide latch onto spring legs between lockplate and latch body until latch is partially over hook cam. Then depress latch and spring until latch clears point of hook.

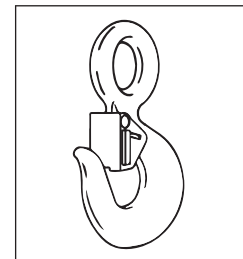

**Steps 4, 5, & 6**

4. Line up holes in latch with hook cam.  
5. Insert bolt through latch, spring, and cam.  
6. Tighten self-locking nut on one end of bolt.

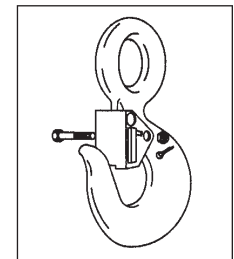

**Step 7 — For Personnel Lifting**

7. With latch in closed position and rigging resting in bowl of hook, insert bolt through latch and secure with nut and cotter pin. When bolt, nut and cotter pin are not being used, store them in a designated place upon the personnel platform.



# Crosby® MODEL PL-N/O HOOK LATCH KIT

## WARNINGS & APPLICATION INSTRUCTIONS



Model PL-N/O

### IMPORTANT SAFETY INFORMATION - READ & FOLLOW

- Always inspect hook and latch before using.
- Never use a latch that is distorted or bent.
- Always make sure spring will force the latch against the tip of the hook.
- Always make sure hook supports the load. The latch must never support the load. (See Figures 1 & 2)
- When placing two (2) sling legs in hook, make sure the angle between the legs is less than 90° and if the hook or load is tilted, nothing bears against the bottom of this latch. (See Figures 3 & 4)
- Latches are intended to retain loose sling or devices under slack conditions.
- Latches are not intended to be an anti-fouling device.

### ⚠ WARNING

- Loads may disengage from hook if proper procedures are not followed.
- A falling load may cause serious injury or death.
- See OSHA Rule 1926.1431(g)(1)(i)(A) and 1926.1501(g)(4)(iv)(B) for Personnel Hoisting by Crane or Derricks. A Crosby or McKissick Hook with a Positive Locked PL-N/O or S-4320 Latch may be used to Lift Personnel.
- Hook must always support the load. The load must never be supported by the latch.
- DO NOT use this latch in applications requiring non-sparking.
- Read and understand these instructions before using hook and latch.

RIGHT



Figure 1

WRONG



Figure 2

RIGHT



Figure 3

WRONG

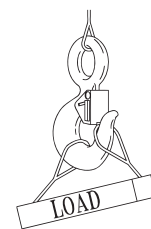
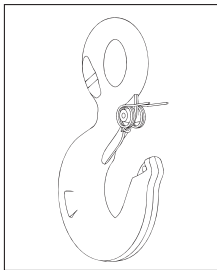

Figure 4

### IMPORTANT - Instructions for Assembling Model PL-N/O Latch on Crosby or McKissick Hooks



Step 1

1. Place hook in upright position. Position coils of spring over cam with legs of spring pointing toward tip of hook, and loop of spring positioned down and lying against the hook.

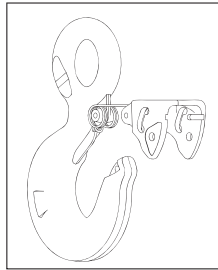

Step 2

2. Slip the latch over the spring until the two spring legs are positioned into the grooves located on the inside of the latch housing (legs of spring should fit between the gate and the housing).

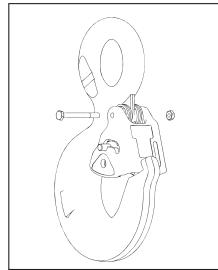

Step 3 4, 5, & 6

3. Slide latch housing up the spring legs until latch clears hook tip.  
4. Resting latch on interlocking hook tip, line up holes in latch with hook cam.  
5. Insert bolt through latch spring & cam.  
6. Tighten self-locking nut on one end of bolt.

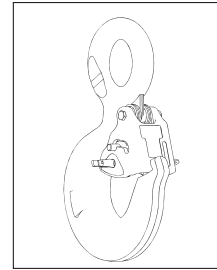

Step 7,8 - For Personnel Lifting

7. Rigging should be resting in bowl of hook, with latch in closed position and gate locked.  
8. Insert toggle lock pin through hole and depress spring until toggle clears hole on other side of latch.

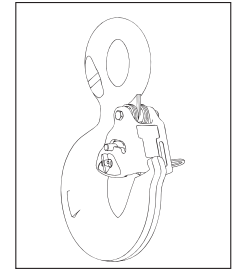

Step 9 - For Personnel Lifting

9. Rotate toggle 90 degrees to secure pin (ensure toggle is in closed position as shown).



# Crosby® ROV HOOKS

## WARNINGS & APPLICATION INSTRUCTIONS



**QUIC-CHECK®** Hoist hooks incorporate markings forged into the product which address two (2) **QUIC-CHECK®** features:



**Deformation Indicators** – Two strategically placed marks, one just below the shank or eye and the other on the hook tip, which allows for a **QUIC-CHECK®** measurement to determine if the throat opening has changed, thus indicating abuse or overload.

**To check**, use a measuring device (i.e., tape measure) to measure the distance between the marks. The marks should align to either an inch or half-inch increment on the measuring device. If the measurement does not meet criteria, the hook should be inspected further for possible damage.

**Angle Indicators** – Indicates the maximum included angle which is allowed between two (2) sling legs in the hook. These indicators also provide the opportunity to approximate other included angles between two sling legs.

### IMPORTANT SAFETY INFORMATION - READ & FOLLOW

- A visual periodic inspection for cracks, nicks, wear, gouges and deformation as part of a comprehensive documented inspection program, should be conducted by trained personnel in compliance with the schedule in ANSI B30.10 and/or regulations governing your industry or jurisdiction.
- For ROV hooks used in frequent load cycles or pulsating loads, the ROV hook components (hoist hook, eye bolt and hexagon body) and their threads should be periodically inspected by Magnetic Particle or Dye Penetrant (Disassembly will be required).
- Disassemble the eye bolt and shank hook from hexagon body (sizes up to and including 31.5t WLL). This requires removing the 2 spiral pins and unscrewing the eye bolt and hoist hook.
- Always use new spiral pins when re-assembling the ROV Hook.
- After reassembly, Crosby recommends a proof test equal to 2 times the ROV hook's stated WLL.
- Never use a hoist hook whose throat opening has been increased, or whose tip has been bent more than 10 degrees out of plane from the hook body, or is in any other way distorted or bent. Note: A latch will not work properly on a hook with a bent or worn tip.
- Never use a hoist hook that is worn beyond the limits shown in Figure 1.
- Remove from service any hoist hook with a crack, nick or gouge. Hoist hooks with a nick or gouge shall be repaired

## ⚠ WARNING

- Loads may disengage from hook if proper procedures are not followed.
- A falling load may cause serious injury or death.
- Hook must always support the load. The load must never be supported by the latch.
- Read and understand these instructions before using hook and latch.

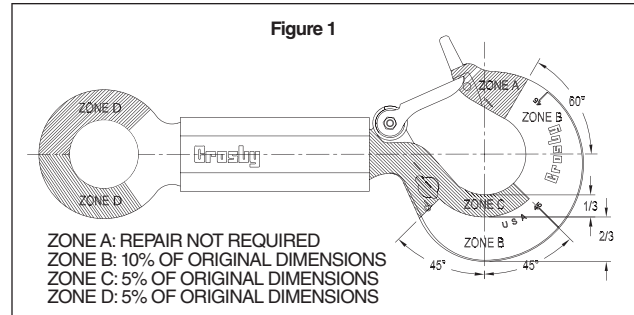

by grinding lengthwise, following the contour of the hook, provided that the reduced dimension is within the limits shown in Figure 1. Contact Crosby Engineering to evaluate any cracks.

- Never repair, alter, rework, or reshape an ROV hook by welding, heating, burning, or bending.
- Remove from service a hoist hook or eye bolt which has threads corroded more than 20% of the hexagon body engagement length.
- Never side load, back load, or tip load the hoist hook, eye bolt or hexagon body. (Side loading, back loading and tip loading are conditions that damage and reduce the capacity of the ROV hook). (See Figure 2.)
- The use of a latch may be mandatory by regulations or safety codes. Follow the regulations governing your industry

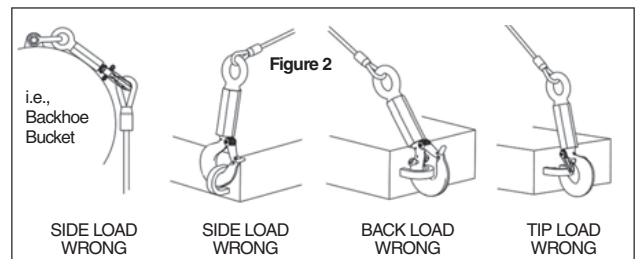

or jurisdiction.

- Always make sure the hook supports the load. (See Figure 3 on page 156). The latch must never support the load (See Figure 4 on page 156).
- When placing two (2) sling legs in hook, make sure the angle from the vertical to the outermost leg is not greater than 45 degrees, and the included angle between the legs does not exceed 90 degrees (See Figure 5 on page 156).
- See ANSI/ASME B30.10 "Hooks" for additional information.
- Remove from service any eye bolt with a crack, nick or gouge. Eye bolt with a nick or gouge shall be repaired by grinding lengthwise, following the contour of the eye bolt, provided that the reduced dimension is no greater than 5% of original dimension. Contact Crosby Engineering to evaluate any cracks.



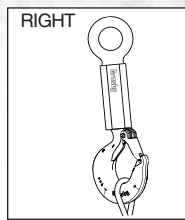

Figure 3

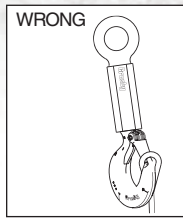

Figure 4

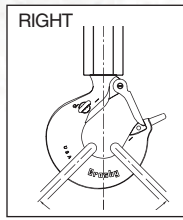

Figure 5

\* For two legged slings with angles greater than 90 degrees, use an intermediate link such as a master link or bolt type shackle to collect the legs of the slings. The intermediate link can be placed over the hook to provide an in-line load on the hook. This approach must also be used when using slings with three or more legs.

- Never use an eye bolt if eye or shank is bent or elongated.
- Remove from service the hexagon body if internal threads are corroded beyond 20% of the eye bolt or hoist hook shank's threaded engagement lengths.
- Hexagon body with nicks or gouges may be repaired by grinding lengthwise.
- Inspect the spiral pin holes on the hoist hook, hexagon body and eye bolt. At assembly, the spiral pin must engage with a press fit.

## Warning and Application Instructions for Crosby® Hook Latch

### Important Safety Information – Read & Follow

- Always inspect hook and latch before using.
- Never use a latch that is distorted or bent.
- Always make sure spring will force the latch against the tip of the hook.
- Always make sure hook supports the load. The latch must never support the load. (See Figures 1 & 2)
- When placing two (2) sling legs in hooks, make sure the angle between the legs is less the 90° and if the hook or load is tilted, nothing bears against the bottom of this latch. (See Figures 3 & 4)
- Latches are intended to retain loose sling or devices under slack conditions.
- Latches are not intended to be an anti-fouling device.

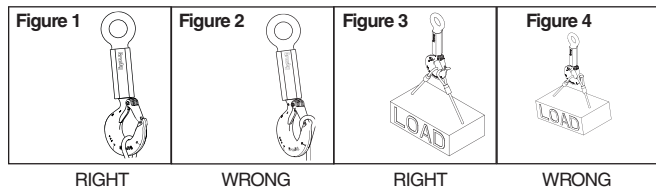

### ⚠ WARNING

- Loads may disengage from hook if proper procedures are not followed.
- A falling load may cause serious injury or death.
- See OSHA Rule 1926.550 (g)(4)(iv)(B) for personnel hoisting for cranes and derricks. Only a Crosby or McKissick hook with a PL Latch attached and secured with bolt, nut and cotter (or Crosby Toggle Pin) or a Crosby hook with a S-4320 Latch attached and secured with a cotter pin, or a Crosby SHUR-LOC® hook in the locked position may be used for any personnel hoisting. A hook with a Crosby SS-4055 latch attached shall NOT be used for personnel lifting.
- Hook must always support the load. The load must never be supported by the latch.
- Read and understand these instructions before using hook and latch.





# RIGGING ACCESSORIES

With Product Warnings and Application Information

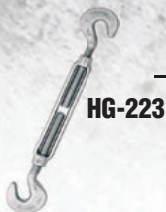

**Crosby**

# "There is No Equal"

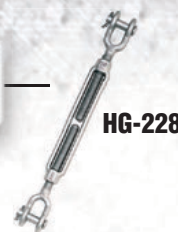
*The Market Leader: Yesterday Today and Tomorrow*

## Rigging Accessories

### DESIGN

The theoretical reserve capability of turnbuckles should be five times the Working Load Limit (FF-T-791). Known as the DESIGN FACTOR, it is usually computed by dividing the catalog ultimate load by the Working Load Limit. The ultimate load is the average load or force at which the product fails or no longer supports the load. The Working Load Limit is the maximum mass or force which the product is authorized to support in general service. The design factor is generally expressed as a ratio, such as 5 to 1.

### THE COMPETITION

**Ask:** *What is the design factor?*

Most competitors do not provide turnbuckle assemblies that exceed Crosby's Working Load Limits with a design factor of 5 to 1.

**Crosby**

All turnbuckles are designed with a design factor of at least 5 to 1. Crosby turnbuckles have the highest Working Load Limits in the industry. Crosby working load limits and design factors are based on extensive testing.

### HEAT TREATMENT

Heat treatment assures the uniformity of performance and maximizes the properties of the steel. This assures that each turnbuckle will meet its rated strength. The requirements of your job demand this reliability and consistency. All turnbuckle bodies should be normalized and end fittings should be quenched and tempered in order to assure uniformity. These heat treat processes develop a tough material that reduces the risk of a brittle, catastrophic failure, and assures the performance of the turnbuckle assembly.

### THE COMPETITION

**Ask:** *Do they utilize the combination of heat treatment that assures the performance of the turnbuckle assembly?*

Most normalize both the turnbuckle body and end fittings. Some provide turnbuckles in an "as forged" condition.

**Crosby**

All turnbuckles are heat treated. Bodies are normalized, and end fittings are quenched and tempered or normalized. These heat treat processes provide a turnbuckle assembly that has superior impact and fatigue qualities and assures performance.



### GALVANIZE AND THREAD FORM

Galvanizing provides the best resistance to corrosion. Turnbuckle ends are the most highly stressed part of the assembly. This stress is at its peak at the root of the threaded shank. The turnbuckle ends should be threaded with a modified thread that minimizes the stress at the root of the thread.

### THE COMPETITION

**Ask:** *Do they use the modified UNJ thread?*

Most galvanize their turnbuckles but do not utilize the modified thread.

**Crosby**

All turnbuckles are available galvanized. Turnbuckle ends are threaded with a modified UNJ thread. This thread form, in conjunction with quench and tempering, gives Crosby turnbuckles their superior impact and fatigue performance.

### FULL LINE AND IDENTIFICATION

The proper application of turnbuckles requires that the correct type and size of turnbuckle be used. The turnbuckle size, the manufacturer's logo, and a product identification code should be clearly and boldly marked in the end fittings as well as in the turnbuckle body. Traceability of the material chemistry is essential for total confidence in the manufacturer of the product. Availability over the full range of sizes of hook, eye, and jaw type turnbuckle assemblies is essential for flexibility in the design of a total system.

### THE COMPETITION

**Ask:** *Do they have a traceability system?*

**Ask:** *Is the full range of type and size turnbuckles offered?*

Most competitors do not have the full line that Crosby produces, or a traceability system.

**Crosby**

Crosby forges its logo, sizes, and the Product Identification Code (PIC) into each component of its full line of hook, jaw, and eye type turnbuckles.

**Remember: "When buying Crosby, you're buying more than product, you're buying Quality."**



# Crosby® VALUE ADDED

- **Charpy Impact Properties:** Crosby's quenched, tempered and normalized end fittings and normalized bodies have enhanced impact properties for greater toughness at all temperatures. If requested at the time of order, Crosby can provide Charpy impact properties.
- **Fatigue Properties:** Typical fatigue properties are available for selected sizes. Crosby turnbuckles are designed with quenched, tempered or normalized end fittings and modified UNJ threads for improved fatigue properties.
- **Typical Hardness Levels, Tensile Strengths and Ductility Properties:** These properties are available for all sizes.
- **Inspection:** If requested at the time of order, turnbuckles can be furnished proof tested or magnaflux inspected with certificates.
- **Full Line:** Turnbuckle assembly combinations include: Eye and Eye, Hook and Hook, Hook and Eye, Jaw and Jaw, Jaw and Eye.
- **Hot Dip Galvanize:** Turnbuckle components have a high quality "hot dip" galvanize finish. Self colored turnbuckle bodies are available upon request.
- **Jaw Ends:** Jaw ends are fitted with bolts and nuts (7mm through 16mm), or pins and cotters (19mm through 70mm).
- **Turnbuckle Eyes:** Eyes are elongated by design, maximizing easy attachment in system and minimizing stress in the eye. For turnbuckle sizes 7mm through 63.5, shackles one size smaller can be reeved through the eye.
- **Turnbuckle Hooks:** Crosby forges its turnbuckle hooks with a greater cross sectional area that results in a stronger hook with better fatigue properties.
- **Material Analysis:** Crosby can provide certified material (mill) analysis for each production lot, traceable by the Product Identification Code (PIC). Crosby, through its own laboratory, verifies the analysis of each heat of steel. Crosby purchases only special bar forging quality steel with specific cleanliness requirements and guaranteed hardenability.

## HG-223

### **HOOK & HOOK**

Meets the performance requirements of Federal Specifications FF-T-791b, Type 1, Form 1, Class 5, and ASTM F-1145, except for those provisions required of the contractor.



## HG-225

### **HOOK & EYE**

Meets the performance requirements of Federal Specifications FF-T-791b, Type 1, Form 1, Class 6, and ASTM F-1145, except for those provisions required of the contractor.



## HG-226

### **EYE & EYE**

Meets the performance requirements of Federal Specifications FF-T-791b, Type 1, Form 1, Class 4, and ASTM F-1145, except for those provisions required of the contractor.



## HG-227

### **JAW & EYE**

Meets the performance requirements of Federal Specifications FF-T-791b, Type 1, Form 1, Class 8, and ASTM F-1145, except for those provisions required of the contractor.



## HG-228

### **JAW & JAW**

Meets the performance requirements of Federal Specifications FF-T-791b, Type 1, Form 1, Class 7, and ASTM F-1145, except for those provisions required of the contractor.



## HG-251

### **STUB END**

Meets the performance requirements of Federal Specifications FF-T-791b, Type 1, Form 1, Class 3, and ASTM F-1145, except for those provisions required of the contractor.



# Wire Rope Thimbles



**G-414**

G-414 meets the performance requirements of Federal Specification FF-T-276b Type III, except for those provisions required of the contractor. For additional information, see page 444.

- Available in Hot Dip galvanized or Stainless Steel (Type 304).
- Stainless steel recommended for more corrosive environments where greater protection is required.
- Greater protection against wear and deformation of the wire rope eye.
- Longer service life.
- Meets the performance requirements of EN13411-1:2002.

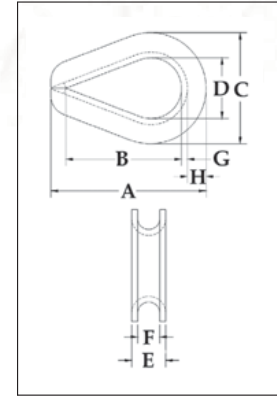

## Extra heavy Wire Rope Thimbles

Rope Dia.		Stock No.		Weight Per 100 (kg)	Dimensions (mm)							
(mm)	(in.)	G-414 Galv.	SS-414 Stainless		A	B	C	D	E	F	G	H
6-7	1/4	1037639	1037960	2.95	55.5	41.4	38.1	22.4	11.2	7.10	1.50	5.85
* 8	5/16	1037657	1037988	5.35	63.5	47.8	46.0	26.9	14.0	8.65	2.05	7.10
* 9-10	3/8	1037675	1038004	9.80	73.0	54.0	54.0	28.7	16.8	10.4	2.80	8.65
11-12	7/16	1037693	-	15.7	82.5	60.5	60.5	31.8	18.8	11.9	3.30	9.65
* 13-15	1/2 - 9/16	1037719	1038022	23.1	92.0	70.0	70.0	38.1	23.4	13.5	3.55	10.4
* 16	5/8	1037755	1038040	34.3	108	82.5	79.5	44.5	26.2	16.8	4.05	12.7
* 18-20	3/4	1037773	1038068	72	127	95.5	96.5	51.0	33.0	19.8	5.60	16.8
22	7/8	1037791	-	81	140	108	108	57.0	37.3	23.9	5.60	19.1
24-26	1	1037817	-	142	156	114	125	63.5	44.5	26.9	6.35	22.4
28-32	1-1/8 - 1-1/4	1037835	-	181	178	130	149	73.0	47.8	33.3	6.35	28.7
32-35	1-1/4 - 1-3/8	1037853	-	402	230	165	173	89.0	57.2	36.6	9.65	28.7
35-38	1-3/8 - 1-1/2	1037871	-	587	229	159	181	89.0	66.5	39.6	12.7	28.7
40	1-5/8	1037899	-	771	286	203	207	102	76.2	43.7	12.7	35.1
44	1-3/4	1037915	-	805	310	229	216	114	77.7	46.7	12.7	33.3
48-52	1-7/8 - 2	1037933	-	1259	384	305	264	152	85.9	53.0	12.7	38.1
56	2-1/4	1037951	-	1792	435	356	302	178	98.6	60.5	16.0	41.4

\*SS-414 sizes available in stainless steel type 304



**G-414 SL**

G-414 SL meets the performance requirements of Federal Specification FF-T-276b Type III, except for those provisions required of the contractor. For additional information, see page 452.

- Prevents the shackle from being removed and replaced in the field, which could compromise the certified integrity of the sling assembly.
- Available in Hot Dip galvanized. Crosby's shackle locking thimbles are galvanized after the welding of the wedge has been completed.
- Greater protection against wear and deformation of the wire rope eye.
- Longer service life.
- Meets the performance requirements of EN13411-1:2002.

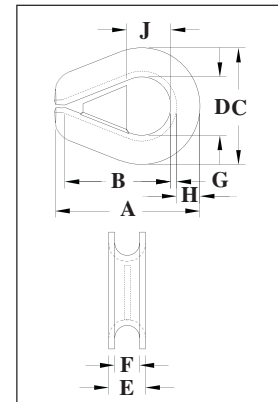

Scan our QR code with your smart device to visit the online flyer.



## Extra Heavy Wire Rope Thimbles (Shackle-Loc)

Rope Dia.		Stock No.	Weight Per 100 (kg)	Dimensions (mm)								
(mm)	(in.)	G-414 Galv.		A	B	C	D	E	F	G	H	J
* 9-10	3/8	1036800	9.80	73.0	54.0	54.0	28.7	16.8	10.4	2.80	8.65	20.5
* 13-15	1/2 - 9/16	1036808	23.1	92.0	70.0	70.0	38.1	23.4	13.5	3.55	10.4	28.4
* 16	5/8	1036817	34.3	108	82.5	79.5	44.5	26.2	16.8	4.05	12.7	31.7
* 18-20	3/4	1036826	72	127	95.5	96.5	51.0	33.0	19.8	5.60	16.8	38.1
22	7/8	1036835	81	140	108	108	57.0	37.3	23.9	5.60	19.1	41.4
24-26	1	1036844	142	156	114	125	63.5	44.5	26.9	6.35	22.4	47.7
28-32	1-1/8 - 1-1/4	1036853	181	178	130	149	73.0	47.8	33.3	6.35	28.7	54.1
35-38	1-3/8 - 1-1/2	1036862	587	229	159	181	89.0	66.5	39.6	12.7	28.7	63.5



# Wire Rope Thimbles



**G-411**

- Hot Dip galvanized steel.
- The standard choice for light duty applications and loading conditions.
- Meets the performance requirements of EN13411-1:2002.

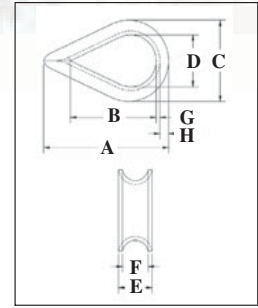

## Standard Wire Rope Thimbles

Rope Dia.		G-411 Stock No	Weight Per 100 (kg)	Dimensions (mm)							
(mm)	(in.)			A	B	C	D	E	F	G	H
3-4	1/8	1037256	1.59	49.3	33.3	26.9	17.5	6.35	4.05	1.25	3.30
5	3/16	1037274	1.59	49.3	33.3	26.9	17.5	7.85	5.60	1.25	3.30
6-7	1/4	1037292	1.59	49.3	33.3	26.9	17.5	9.65	7.10	1.25	3.30
8	5/16	1037318	1.81	54.0	38.1	31.8	20.6	11.2	8.65	1.25	3.30
9-10	3/8	1037336	3.04	60.5	41.4	37.3	23.9	13.5	10.4	1.50	4.06
11-13	1/2	1037354	5.67	70.0	47.8	44.5	28.7	17.5	13.5	2.05	4.83
16	5/8	1037372	15.7	89.0	57.0	60.5	35.1	23.1	16.8	3.30	8.64
18-20	3/4	1037390	21.4	95.5	63.5	68.5	41.4	27.4	19.8	3.55	8.64
22	7/8	1037416	38.4	127	89.0	81.0	47.8	32.3	23.9	4.05	11.2
24-26	1	1037434	44.2	145	108	95.5	63.5	35.3	26.9	4.05	10.4
28-32	1-1/8 - 1-1/4	1037452	79	159	114	109	70.0	44.5	33.3	5.60	12.7

G-411 meets the performance requirements of Federal Specification FF-T-276b Type II, except for those provisions required of the contractor. For additional information, see page 444.



**G-408**  
(Open Pattern)

- Hot Dip galvanized Steel.
- Meets the performance requirements of EN13411-1:2002.
- Recommended for light duty applications in which it is being assembled into another fitting (i.e., shackle or master link).

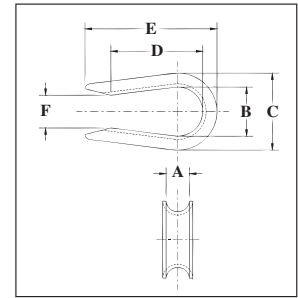

## Open Pattern Thimbles

Rope Dia.		G-408 Stock No.	Weight Per 100 (kg)	Dimensions (mm)					
(mm)	(in.)			A	B	C	D	E	F
6-7	1/4	1037531	1.36	7.10	17.5	26.9	35.8	51.5	9.65
8	5/16	1037559	1.72	8.65	20.6	31.8	38.9	55.0	12.7
9-10	3/8	1037577	3.18	11.2	23.9	37.3	43.7	62.5	15.7
11-13	1/2	1037595	5.67	13.5	28.4	44.5	37.3	72.0	19.1
16	5/8	1037611	11.3	16.8	35.1	60.5	59.5	91.0	25.4



**S-412**

- Cast Ductile Iron.
- Fits pin for open wire rope socket, boom pendant clevis and wedge socket.

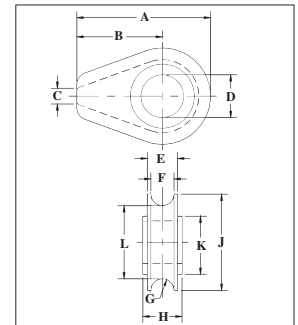

## Solid Wire Rope Thimbles

Rope Dia.		S-412 Stock No.	Weight Each Per 100 (kg)	Dimensions (mm)										
(mm)	(in.)			A	B	C	D	E	F	G	H	J	K	L
13	1/2	1037121	.28	71.5	44.5	6.35	26.9	19.1	14.2	7.10	22.4	54.0	41.4	39.6
16	5/8	1037149	1.00	119	76.0	9.65	33.3	26.9	20.6	10.4	28.7	86.0	57.0	65.0
18-20	3/4	1037167	1.05	119	76.0	9.65	38.1	26.9	20.6	10.4	35.1	86.0	57.0	65.0
22	7/8	1037185	2.47	154	97.0	12.7	44.5	35.1	26.9	13.5	41.4	114	82.5	87.5
24-26	1	1037201	2.38	154	97.0	12.7	54.0	35.1	26.9	13.5	46.0	114	82.5	87.5
28-30	1-1/8	1037229	4.21	184	116	16.0	60.5	44.5	33.3	16.8	52.5	137	98.5	103
32-35	1-1/4 - 1-3/8	1037247	4.45	184	116	16.0	67.0	49.3	38.9	19.8	58.5	137	98.5	105

# Alloy Master Links



**A-342**  
Alloy Master Links

- Alloy Steel — Quenched and Tempered.
- Individually Proof Tested to values shown, with certification.
- Proof Tested with 60% inside width special fixtures sized to prevent localized point loading per ASME A-952 , reference page 276.
- Forgings have a Product Identification Code (PIC) for material traceability, along with the size, the name Crosby and USA in raised lettering.
- Selected sizes designated with "W" in the size column have enlarged inside dimensions to allow additional room for sling hardware and crane hook.
- Crosby 32mm to 51mm 342/345 master links are type approved to DNV Certification Notes 2.7-1- Offshore Containers. These Crosby master links are 100% proof tested, MPI and impact tested. The tests are conducted by Crosby and 3.1 test certification is available upon request. Refer to page 164 for Crosby COLD TUFF® master links that meet the additional requirements of DNV rules for certification of lifting appliances - Loose Gear.
- Incorporates patented **QUIC-CHECK®** deformation indicators.
- Meets or exceeds all requirements of ASME B30.26 including identification, ductility, design factor, proof load and temperature requirements. Importantly, these links meet other critical performance requirements including fatigue life, impact properties and material traceability, not addressed by ASME B30.26.

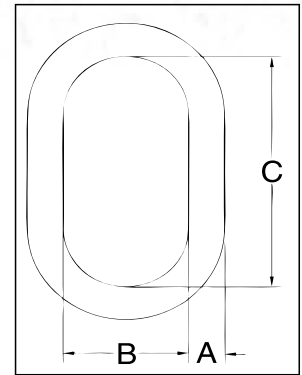

Load Rated

Fatigue Rated



MAXTOUGH®



## A-342 Alloy Master Links

Size		A-342 Stock No.	Weight Each (kg)	WLL S.F.= 5/1 for Rope (t)*	Proof Load (kN)**	Dimensions (mm)			Deformation Indicator
(mm)	(in.)					A	B	C	
13W	1/2W	1014266	0.59	3.40	77	13	71.1	127	89
16	5/8	1014280	0.69	4.00	80	16	76.2	152	89
19W	3/4W	1014285	0.91	5.60	126	19	81.3	152	102
22W	7/8W	1014319	1.50	6.90	157	22	95.3	162	114
26W	1W	1014331	2.77	11.8	267	26	109	191	140
32W	1-1/4W	1014348	5.44	17.7	402	32	140	241	178
† 32W	† 1-1/4W	1262505	4.17	† 16.4	403	32	111	222	140
38W	1-1/2W	1014365	8.44	27.7	628	38	150	267	191
† 38W	† 1-1/2W	1262514	7.21	† 24.6	604	38	133	267	165
44	1-3/4	1014388	11.4	38.5	944	44	152	305	191
† 44	† 1-3/4	1262523	11.2	† 38.5	944	44	152	305	191
51	2	1014404	16.8	46.5	1141	51	178	356	229
† 51	† 2	1262532	17.1	† 46.5	1141	51	178	356	229
57	2-1/4	1014422	24.5	64.9	1287	57	203	406	254
63	2-1/2	1014468	31.1	72.6	1423	63	213	406	279
70	2-3/4	1014440	42.6	98.4	1930	70	251	457	318
76	3	1014486	52.0	103	2029	76	251	457	330
83	3-1/4	1014501	66.0	119	2332	83	254	508	343
89	3-1/2	1014529	91.0	126	2483	89	305	610	394
95	3-3/4	1015051	90.0	152	2990	95	254	508	343
102	4	1015060	120	169	3319	102	305	610	406
†† 108	†† 4-1/4	1015067	137	160	3150	108	305	610	-
†† 114	†† 4-1/2	1015079	156	163	3202	114	356	711	-
†† 121	†† 4-3/4	1015088	198	176	3460	121	356	711	-
†† 127	†† 5	1015094	234	179	3515	127	381	762	-

\*Ultimate Load is 5 times the Working Load Limit. Based on single leg sling (in-line load), or resultant load on multiple legs with an included angle less than or equal to 120 degrees. Applications with wire rope and synthetic sling generally require a design factor of 5. \*\*Proof Test Load equals or exceeds the requirement of ASTM A952(8.1) and ASME B30.9. †Ultimate Load is 4 times the Working Load Limit for Offshore Container Master Links. †Offshore Container Master Links Proof Tested to 2.5 times the Working Load Limit with 70 percent fixtures. †† Welded Master Link.



For use with chain slings, refer to page 243 for sling ratings and page 240 for proper master link selection.



# Alloy Master Links with Engineered Flat



**A-345**  
Alloy Master  
Links

- Alloy Steel — Quenched and Tempered.
- Individually Proof Tested to values shown, with certification.
- Proof Tested with 60% inside width special fixtures sized to prevent localized point loading per ASME A-952 , reference page 276.
- Forgings have a Product Identification Code (PIC) for material traceability, along with the size, the name Crosby and USA in raised lettering.
- Selected sizes designated with "W" in the size column have enlarged inside dimensions to allow additional room for sling hardware and crane hook.
- Crosby 32mm to 51mm 342/345 master links are type approved to DNV Certification Notes 2.7-1- Offshore Containers. These Crosby master links are 100% proof tested, MPI and impact tested. The tests are conducted by Crosby and 3.1 test certification is available upon request. Refer to page 164 for Crosby COLD TUFF® master links that meet the additional requirements of DNV rules for certification of lifting appliances - Loose Gear.
- Incorporates patented **QUIC-CHECK®** deformation indicators.
- Meets or exceeds all requirements of ASME B30.26 including identification, ductility, design factor, proof load and temperature requirements. Importantly, these links meet other critical performance requirements including fatigue life, impact properties and material traceability, not addressed by ASME B30.26.

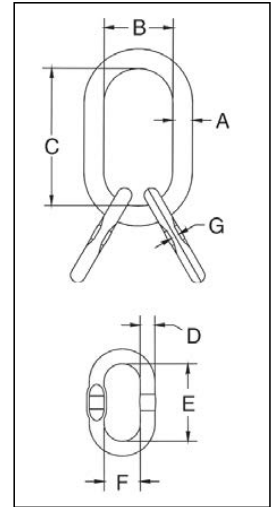

Load Rated

Fatigue Rated



MAXTOUGH



## A-345 Master Link Assembly with Engineered Flat for use with S-1325A coupler link.

Size		A-345 Stock No.	Weight Each (kg)	Working Load Limit Based on 5:1 Design Factor (t)*	Proof Load (kN)**	Dimensions (mm)							Deformation Indicator
(mm)	(in.)					A	B	C	D	E	F	G	
19W	3/4W	1014739	1.59	5.6	126	19	81.3	152	14.2	85.1	45.0	7.62	102
22W	7/8W	1014742	2.18	6.9	157	22	95.3	162	14.2	85.1	45.0	7.62	114
26W	1W	1014766	4.22	11.8	267	26	109	191	19.1	100	59.9	8.38	140
32W	1-1/4W	1014779	7.17	17.7	402	32	140	241	25.4	160	89.9	13.0	178
† 32W	† 1-1/4W	126260	12.5	† 16.4	403	32	111	222	32	222	111	-	140
38W	1-1/2W	1014807	15.47	27.7	628	38	150	267	31.8	180	100	16.5	191
† 38W	† 1-1/2W	1262612	21.6	† 24.6	604	38	133	267	38	267	133	-	160
44	1-3/4	1014814	20.9	38.5	944	44	152	305	35.1	203	127	18.5	191
† 44	† 1-3/4	1262621	33.7	† 38.5	944	44	152	305	44	305	152	-	191
51	2	1014832	30.4	46.5	1141	51	178	356	38.1	229	146	-	229
† 51	† 2	1262630	51.3	† 46.5	1141	51	178	356	51	356	178	-	229
64	2-1/2	1014855	93.4	72.6	1423	64	213	406	63.5	406	213	-	279
70	2-3/4	1014864	128	98.4	1929	70	251	457	69.9	457	251	-	318
102	4	1014999	303	169	3319	102	305	610	89.0	610	305	-	394***

\* Ultimate Load is 5 times the Working Load Limit. The maximum individual sublink working load limit is 75% of the assembly working load limit except for 2-1/2" and 2-3/4", which are 100% of assembly working load limit. Applications with wire rope and synthetic sling generally require a design factor of 5. \*\*Proof Test Load equals or exceeds the requirement of ASTM A952(8.1) and ASME B30.9. †Ultimate Load is 4 times the Working Load Limit for Offshore Container Master Links. †Offshore Container Master Links Proof Tested to 2.5 times the Working Load Limit with 70 percent fixtures. †† Welded Master Link.



For use with chain slings, refer to page 244 for sling ratings and page 240 for proper master link selection.

RIGGING ACCESSORIES

## Welded Master Links with Engineered Flat



**A-344**  
Welded Master Links

Ultimate Load is 5 times the Working Load Limit. Applications with wire rope and synthetic sling generally require a design factor of 5. Based on single leg sling (in-line load), or resultant load on multiple legs with an included angle less than or equal to 120 degrees. \*\* Proof Test Load equals or exceeds the requirement of ASTM A952(8.1) and ASME B30.9. For use with chain slings, refer to page 245 for sling ratings and page 240 for proper master link selection.

- Alloy Steel — Quenched and Tempered.
- Individually Proof Tested to values shown, with certification.
- Proof Tested with 60% inside width special fixtures sized to prevent localized point loading per ASME A-952 , reference page 276.
- Forgings have a Product Identification Code (PIC) for material traceability, along with the size, the name Crosby and USA in raised lettering.
- Selected sizes designated with "W" in the size column have enlarged inside dimensions to allow additional room for sling hardware and crane hook.
- Crosby 12mm to 57mm 344/347 master links are type approved to DNV Certification Notes 2.7-1- Offshore Containers. These Crosby master links are 100% proof tested, MPI and impact tested. The tests are conducted by Crosby and 3.1 test certification is available upon request. Refer to page 164 for Crosby COLD TUFF® master links that meet the additional requirements of DNV rules for certification of lifting appliances - Loose Gear.
- Incorporates patented **QUIC-CHECK®** deformation indicators.
- Meets or exceeds all requirements of ASME B30.26 including identification, ductility, design factor, proof load and temperature requirements. Importantly, these links meet other critical performance requirements including fatigue life, impact properties and material traceability, not addressed by ASME B30.26.

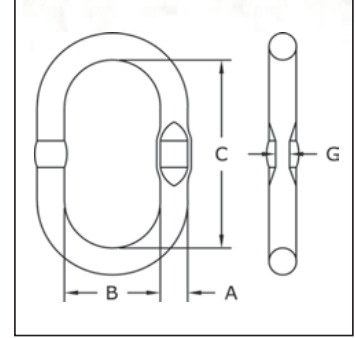

### A-344 Welded Master Links with Engineered Flat

Size		A-344 Stock No.	Weight Each (kg)*	Working Load Limit (t)*	Proof Load (kN)**	Dimensions (mm)				Engineered Flat Size for S-1325A (mm)
(mm)	(in.)					A	B	C	G	
12	7/16	1256862	.30	1.60	39	12.0	60.0	120	6.50	6
13	1/2	1256932	.36	2.50	61	13.0	60.0	120	6.50	7-8
17	11/16	1257002	.86	4.10	101	17.0	90.0	160	8.50	10
19	3/4	1257072	1.08	6.70	164	19.0	90.0	160	8.50	10
20	3/4	1257082	1.17	6.70	164	20.0	80.0	150	—	—
22	7/8	1257214	1.59	8.50	208	22.0	90.0	170	—	—
22	7/8	1257212	1.63	8.50	208	22.0	100	180	10.5	13
22	7/8	1257215	2.39	6.30	154	22.0	145	275	—	—
25	1	1257282	2.43	11.5	282	25.0	115	210	13.5	16
25	1	1257302	2.31	11.5	282	25.0	100	190	—	—
25	1	1257332	3.35	8.90	218	25.0	145	275	—	—
28	1-1/8	1257352	3.22	12.9	316	28.0	110	210	—	—
28	1-1/8	1257382	3.91	13.0	319	28.0	145	275	13.5	16
31	1-7/32	1257422	4.86	17.0	417	31.0	145	275	15.5	—
32	1-1/4	1257442	5.30	17.0	417	32.0	140	270	—	—
36	1-7/16	1257492	6.87	24.0	588	36.0	155	285	—	—
38	1-1/2	1257502	7.63	31.5	772	38.0	140	270	—	—
40	1-9/16	1257532	8.96	28.1	689	40.0	160	300	—	—
45	1-3/4	1257569	10.31	32.0	785	45.0	140	250	—	—
45	1-3/4	1257564	12.70	38.3	939	45.0	170	320	—	—
45	1-3/4	1257562	12.82	38.3	939	45.0	180	340	—	—
50	1-31/32	1257582	17.60	45.0	1103	50.0	200	380	—	—
51	2	1257632	18.72	45.0	1103	51.0	215	390	—	—
57	2-1/4	1257652	24.5	65.3	1601	57.0	203	406	—	—

\*Ultimate Load is 5 times the Working Load Limit. The maximum individual sublink working load limit is 75% of the assembly working load limit except for 63.5 and 70mm, which are 100% of assembly working load limit. Applications with wire rope and synthetic sling generally require a design factor of 5. \*There are no manufactured flats on links over 31mm (24.4). \*\*Proof Test Load equals or exceeds the requirement of ASTM A952(8.1) and ASME B30.9.



For use with chain slings, refer to page 245 for sling ratings and page 243 for proper master link selection.



# Welded Master Links with Engineered Flat



**A-347**  
Welded Master Links

Ultimate Load is 5 times the Working Load Limit. Applications with wire rope and synthetic sling generally require a design factor of 5. Based on single leg sling (in-line load), or resultant load on multiple legs with an included angle less than or equal to 120 degrees. \*\* Proof Test Load equals or exceeds the requirement of ASTM A952(8.1) and ASME B30.9. For use with chain slings, refer to page 245 for sling ratings and page 240 for proper master link selection.

- Alloy Steel — Quenched and Tempered.
- Individually Proof Tested to values shown, with certification.
- Proof Tested with 60% inside width special fixtures sized to prevent localized point loading per ASME A-952 , reference page 276.
- Forgings have a Product Identification Code (PIC) for material traceability, along with the size, the name Crosby and USA in raised lettering.
- Selected sizes designated with “W” in the size column have enlarged inside dimensions to allow additional room for sling hardware and crane hook.
- Crosby 12mm to 57mm 344/347 master links are type approved to DNV Certification Notes 2.7-1- Offshore Containers. These Crosby master links are 100% proof tested, MPI and impact tested. The tests are conducted by Crosby and 3.1 test certification is available upon request. Refer to page 164 for Crosby COLD TUFF® master links that meet the additional requirements of DNV rules for certification of lifting appliances - Loose Gear.
- Incorporates patented **QUIC-CHECK®** deformation indicators.
- Meets or exceeds all requirements of ASME B30.26 including identification, ductility, design factor, proof load and temperature requirements. Importantly, these links meet other critical performance requirements including fatigue life, impact properties and material traceability, not addressed by ASME B30.26.

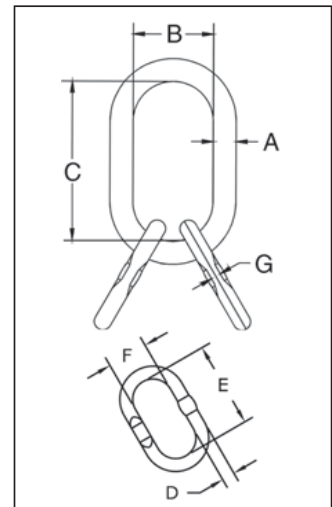

## A-347 Welded Master Link with Engineered Flat

Size		A-347 Stock No.	Weight Each (kg)	Working Load Limit (t)*	Proof Load (kN)**	Dimensions (mm)							Engineered Flat Size for S-1325A (mm)
(mm)	(in.)					A	B	C	D	E	F	G	
13/12	1/2	1257692	.81	2.40	59	13.0	60.0	120	12.0	85.0	45.0	6.00	6
17/13	11/16	1257762	1.56	4.10	101	17.0	90.0	160	13.0	120	60.0	6.50	7
19/13	3/4	1257832	1.80	4.25	104	19.0	90.0	160	13.0	120	60.0	6.50	8
22/20	7/8	1257977	3.93	8.50	208	22.0	90.0	170	20.0	150	80.0	—	—
22/17	7/8	1257972	3.35	7.98	196	22.0	100	180	17.0	160	90.0	8.50	10
22/16	7/8	1257979	3.53	5.80	142	22.0	145	275	16.0	120	60.0	—	—
25/20	1	1258122	4.65	10.7	262	25.0	100	190	20.0	150	80.0	—	—
25/19	1	1258102	5.51	8.90	218	25.0	145	275	19.0	160	90.0	—	—
28/22	1-1/8	1258162	6.40	12.9	316	28.0	110	210	22.0	170	90.0	—	—
28/22	1-1/8	1258142	7.17	14.5	355	28.0	145	275	22.0	180	100	10.5	13
31/25	1-7/32	1258182	9.72	17.0	417	31.0	145	275	25.0	210	115	13.5	16
32/25	1-1/4	1258202	9.92	17.0	417	32.0	140	270	25.0	190	100	—	—
36/28	1-3/8	1258222	12.20	23.6	579	36.0	145	275	28.0	190	100	—	—
38/32	1-1/2	1258224	18.23	28.1	689	38.0	140	270	32.0	270	140	—	—
40/31	1-9/16	1258332	18.68	28.1	689	40.0	160	300	31.0	275	145	—	—
45/38	1-3/4	1258422	27.96	38.3	939	45.0	170	320	38.0	270	140	—	—
45/36	1-3/4	1258402	26.56	38.3	939	45.0	180	340	36.0	285	155	—	—
50/38	2	1258442	32.86	45.0	1103	50.0	200	380	38.0	270	140	—	—
51/45	2	1258462	42.92	45.0	1103	51.0	190	350	45.0	340	180	—	—
57/50	2-1/4	1258482	59.70	67.0	1643	57.0	203	406	50.0	380	200	—	—

\*Ultimate Load is 5 times the Working Load Limit. The maximum individual sublink working load limit is 75% of the assembly working load limit except for 63.5 and 70mm, which are 100% of assembly working load limit. Applications with wire rope and synthetic sling generally require a design factor of 5. \*\*Proof Test Load equals or exceeds the requirement of ASTM A952(8.1) and ASME B30.9.\*\*\* Sublink only.



For use with chain slings, refer to page 246 for sling ratings and page 240 for proper master link selection.



**A-342CT**  
Master Links

- Alloy Steel - Quenched and Tempered
- Individually proof tested at 2 times Working Load Limit with certification.
- Finish is Inorganic Zinc Primer.
- Certified to meet charpy impact testing of 42J. min. avg. at -20° C.
- Individually serialized and all certification shipped with each link.
- COLD TUFF® master links are suitable for use at -46° C.
- Type Approval and certification in accordance with DNV 2.7-1 Offshore Containers, DNV-OS-E101, and Rules for Certification of Lifting Appliances, and are produced in accordance with DNV MSA requirements, including required documents.
- Refer to page 88 for COLD TUFF® Shackles.
- Meets or exceeds all requirements of ASME B30.26 including identification, ductility, design factor, proof load and temperature requirements. Importantly, these fittings meet other critical performance requirements including fatigue life, impact properties and material traceability, not addressed by ASME B30.26.

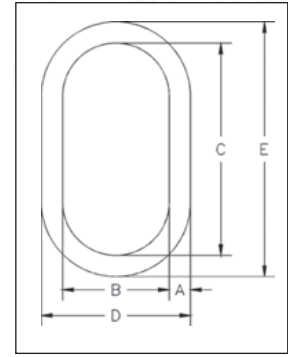

**A-342CT Master Links**

Size (mm)	A-342CT Stock No.	Working Load Limit (t)*	Weight Each (kg)	Dimensions (mm)					Deformation Indicator
				A	B	C	D	E	
31.8W	1261407	15.9	5.44	33.8	140	241	207	309	178
38.1W	1261418	27.7	8.44	40.9	149	267	231	348	191
44.5	1261423	28.3	11.4	44.5	152	305	241	394	191
51.0	1261433	44.3	16.8	51.0	178	356	279	457	229

\*Minimum Ultimate Load is 5 times the Working Load Limit.



**A-345CT**  
Master Links  
Assembly

- Alloy Steel - Quenched and Tempered
- Individually proof tested at 2 times Working Load Limit with certification.
- Finish is Inorganic Zinc Primer.
- Certified to meet charpy impact testing of 42J. min. avg. at -20° C.
- COLD TUFF® master links are suitable for use at -46° C.
- Type Approval and certification in accordance with DNV 2.7-1 Offshore Containers, DNV-OS-E101, and Rules for Certification of Lifting Appliances, and are produced in accordance with DNV MSA requirements, including required documents.
- Refer to page 88 for COLD TUFF® Shackles.
- Meets or exceeds all requirements of ASME B30.26 including identification, ductility, design factor, proof load and temperature requirements. Importantly, these fittings meet other critical performance requirements including fatigue life, impact properties and material traceability, not addressed by ASME B30.26.

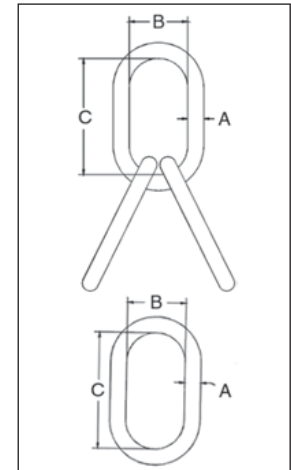

**A-345CT Master Link Assembly**

Size (mm)	A-345CT Stock No.	Working Load Limit (t)*	Weight Each (kg)	Dimensions (mm)		
				A	B	C
31.8	1261609	15.9	13.6	31.8	111	222
38.1	1261620	21.7	23.1	38.1	133	267
44.5	1261631	28.3	35.4	44.5	152	305
51.0	1261642	44.3	56	51.0	178	356

\*Minimum Ultimate Load is 5 times the Working Load Limit.



# Pear Shaped Links



**G-340 / S-340**  
Weldless End Link

- Forged carbon steel - Quenched and Tempered
- Self Colored or Hot Dip galvanized.

G-340 from 16 mm thru 22mm meet the performance requirements of Federal Specification RR-C-271F, Type XV, except for those provisions required of the contractor. For additional information, see page 450.

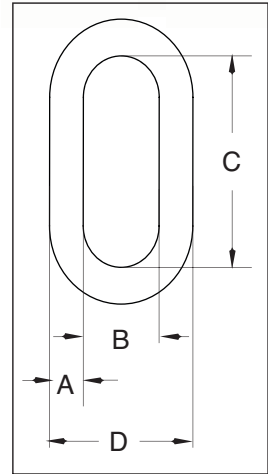

## G-340/S-340 Weldless End Links

Stock No.		Working Load Limit (t)*	Weight Each (kg)	Dimensions (mm)			
G-340 Galv.	S-340 S.C.			A	B	C	D
1014057	1014066	1.13	.07	8	12.7	44.5	30.0
1014075	1014084	1.72	.10	10	14.2	47.8	35.1
1014093	1014100	2.95	.22	13	19.1	60.5	46.0
1014119	1014128	4.22	.44	16	25.4	82.5	59.0
1014137	1014146	6.35	.68	19	28.7	89.0	68.0
1014155	1014164	5.44	1.17	22	51.0	130	95.5
1014173	1014182	6.89	1.79	25	57.0	146	108
1014191	1014208	11.97	3.31	32	63.5	178	127
1014217	1014226	13.61	4.71	35	70.0	197	140

\*Ultimate Load is 5 times the Working Load Limit. Based on single leg sling (in-line load), or resultant load on multiple legs with an included angle less than or equal to 120°.



**S-643**  
Weldless Rings

- Forged carbon steel - Quenched and Tempered.
- Self Colored

Weldless Rings meet the performance requirements of Federal Specification RR-C-271F Type VI, except for those provisions required of the contractor. For additional information, see page 450.

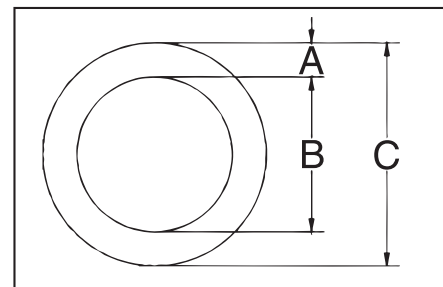

## S-643 Weldless Rings

Size (mm)	S-643 Stock No	Working Load Limit Single Pull (t)*	Weight Each (kg)	Dimensions (mm)		
				A	B	C
22.2 x 102	1013780	3.27	1.23	22.2 x 102	102	146
22.2 x 140	1013806	2.54	1.57	22.2 x 140	140	184
25.4 x 102	1013824	4.90	1.67	25.4 x 102	102	152
28.6 x 152	1013842	4.72	2.99	28.6 x 152	152	210
31.8 x 127	1013860	7.71	3.09	31.8 x 127	127	191
34.9 x 152	1013888	8.62	4.59	34.9 x 152	152	222

\*Ultimate Load is 6 times the Working Load Limit.

## Pear Shaped Links



**A-341**  
Alloy Pear Shaped Links

- Alloy Steel - Quenched and Tempered
- Individually Proof Tested at 2 times Working Load Limit with certification.
- Proof Test certification shipped with each link.
- Sizes 13mm, 16mm, 19mm, 22mm, 25mm, 32mm and 35mm are forged.

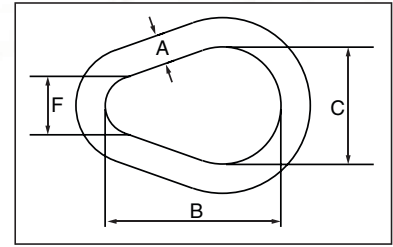

### A-341 Alloy Pear Shaped Links

Stock Size (A) (mm)	A-341 Stock No	Working Load Limit		Weight Each (kg)	Dimensions (mm)		
		(t)*	(lbs.)		B	C	F
13	1013575	3.15	7000	.25	76.2	50.8	25.4
16	1013584	4.09	9000	.50	95.3	63.5	31.8
19	1013595	5.59	12300	.80	114	76.2	38.1
22	1013604	6.81	15000	1.28	133	88.9	44.5
25	1013613	11.0	24360	1.91	152	102	51.0
28	1013622	13.9	30600	2.83	171	114	57.0
32	1013631	16.4	36000	3.74	191	127	63.5
35	1013640	19.5	43000	5.10	210	140	70.0
†† 38	1013649	24.7	54300	6.46	229	152	76.0
†† 42	1013658	28.4	62600	8.39	248	165	82.5
†† 44	1013667	38.6	84900	10.2	267	178	89.0
†† 48	1013676	43.5	95800	13.2	286	191	95.5
†† 51	1013685	46.6	102600	15.4	305	203	102
†† 57	1013694	65.0	143100	21.8	343	229	114
†† 64	1013703	66.9	147300	29.9	381	254	127
†† 70	1013712	98.6	216900	39.9	419	279	140
†† 76	1013721	103	228000	52	457	305	152
†† 83	1013730	119	262200	66	495	330	165
†† 89	1013739	126	279000	82	533	356	178
†† 102	1013748	169	373000	123	610	406	203

\*Based on single leg sling (in-line load), or resultant load on multiple legs with an included angle less than or equal to 120°. Minimum Ultimate load is 5 times the Working Load Limit. †† Welded Link.



**G-341 / S-341**  
Weldless Sling Link

- Forged carbon steel - Quenched and Tempered.
- Self Colored or Hot Dip galvanized.

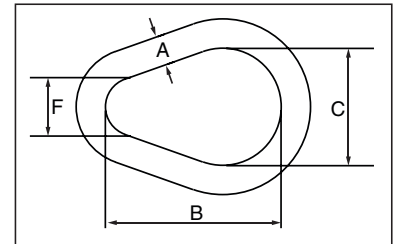

### G-341 / S-341 Weldless Sling Links

Size (A) (mm)	Stock No.		Working Load Limit Single Pull (t.)*	Weight Each (kg)	Dimensions (mm)		
	G-341 Galv.	S-341 S.C.			B	C	F
10	1013897	1013904	.82	0.10	57.2	38.1	19.1
13	1013913	1013922	1.32	.25	76.2	50.8	25.4
16	1013931	1013940	1.91	.48	95.5	63.5	31.8
19	1013959	1013968	2.72	.85	114	76.2	38.1
22	1013977	1013986	3.76	1.25	133	88.9	44.5
25	1013995	1014002	4.90	1.97	152	102	51.0
32	1014011	1014020	7.60	3.45	197	127	63.5
35	1014039	1014048	9.30	5.13	210	140	70.0

\*Ultimate Load is 6 times the Working Load Limit. Based on single leg sling (in-line load), or resultant load on multiple legs with an included angle less than or equal to 120°.



# Forged Eye Bolts



**G-291**  
Regular Nut  
Eye Bolt

- Forged Steel - Quenched and Tempered.
- Fatigue rated at 1-1/2 times the Working Load Limit at 20,000 cycles.
- All Bolts Hot Dip galvanized after threading (UNC).
- Furnished with standard Hot Dip galvanized hex nuts.
- Recommended for in-line pull.
- Meets or exceeds all requirements of ASME B30.26 including identification, ductility, design factor, proof load and temperature requirements. Importantly, these bolts meet other critical performance requirements including fatigue life, impact properties and material traceability, not addressed by ASME B30.26.

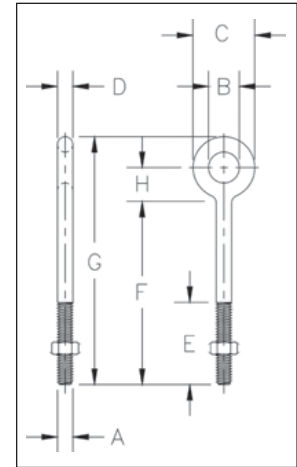

**Fatigue Rated**



## G-291 Regular Nut Eye Bolts

Shank Dia. & Length (mm)	G-291 Stock No.	Working Load Limit (t)*	Weight Per 100 (kg)	Dimensions (mm)							
				A	B	C	D	E	F	G	H
6.35 x 51.0	1043230	.29	3.72	6.35	12.7	25.4	6.35	38.1	51.0	77.5	14.2
6.35 x 102	1043258	.29	5.31	6.35	12.7	25.4	6.35	63.5	102	129	14.2
7.94 x 57.0	1043276	.54	6.03	7.85	15.7	31.8	7.85	38.1	57.0	90.5	17.5
7.94 x 108	1043294	.54	11.3	7.85	15.7	31.8	7.85	63.5	108	141	17.5
9.53 x 63.5	1043310	.70	10.6	9.65	19.1	38.1	9.65	38.1	63.5	105	22.4
9.53 x 114	1043338	.70	13.4	9.65	19.1	38.1	9.65	63.5	114	155	22.4
9.53 x 152	1043356	.70	16.0	9.65	19.1	38.1	9.65	63.5	152	194	22.4
12.7 x 82.5	1043374	1.18	22.8	12.7	25.4	51.0	12.7	38.1	82.5	137	28.4
12.7 x 152	1043392	1.18	30.0	12.7	25.4	51.0	12.7	76.0	152	206	28.4
12.7 x 203	1043418	1.18	37	12.7	25.4	51.0	12.7	76.0	203	257	28.4
12.7 x 254	1043436	1.18	40	12.7	25.4	51.0	12.7	76.0	254	308	28.4
12.7 x 305	1043454	1.18	52	12.7	25.4	51.0	12.7	76.0	305	359	28.4
15.9 x 102	1043472	2.35	47	15.7	31.8	63.5	15.7	51.0	102	170	36.6
15.9 x 152	1043490	2.35	54	15.7	31.8	63.5	15.7	76.0	152	221	36.6
15.9 x 203	1043515	2.35	61	15.7	31.8	63.5	15.7	76.0	203	272	36.6
15.9 x 254	1043533	2.35	70	15.7	31.8	63.5	15.7	76.0	254	322	36.6
15.9 x 305	1043551	2.35	76	15.7	31.8	63.5	15.7	102	305	373	36.6
19.1 x 114	1043579	3.26	76	19.1	38.1	76.0	19.1	51.0	114	195	42.9
19.1 x 152	1043597	3.26	84	19.1	38.1	76.0	19.1	76.0	152	233	42.9
19.1 x 203	1043613	3.26	94	19.1	38.1	76.0	19.1	76.0	203	284	42.9
19.1 x 254	1043631	3.26	107	19.1	38.1	76.0	19.1	76.0	254	335	42.9
19.1 x 305	1043659	3.26	117	19.1	38.1	76.0	19.1	102	305	386	42.9
19.1 x 381	1043677	3.26	135	19.1	38.1	76.0	19.1	127	381	462	42.9
22.2 x 127	1043695	4.80	122	22.4	44.5	89.0	22.4	63.5	127	222	51.0
22.2 x 203	1043711	4.80	140	22.4	44.5	89.0	22.4	102	203	298	51.0
22.2 x 305	1043739	4.80	181	22.4	44.5	89.0	22.4	102	305	400	51.0
25.4 x 152	1043757	6.03	191	25.4	51.0	102	25.4	76.0	152	262	58.5
25.4 x 229	1043775	6.03	213	25.4	51.0	102	25.4	102	229	338	58.5
25.4 x 305	1043793	6.03	245	25.4	51.0	102	25.4	102	305	414	58.5
25.4 x 457	1043819	6.03	295	25.4	51.0	102	25.4	178	457	567	58.5
31.8 x 203	1043837	9.52	340	31.8	63.5	127	31.8	102	203	340	73.0
31.8 x 305	1043855	9.52	408	31.8	63.5	127	31.8	102	305	441	73.0
31.8 x 508	1043873	9.52	549	31.8	63.5	127	31.8	152	508	645	73.0

\*Ultimate Load is 5 times the Working Load Limit. Working Load Limit shown is for in-line pull. Maximum Proof Load is 2 times the Working Load Limit.

## Forged Eye Bolts



**G-277**  
Shoulder Nut  
Eye Bolts

- Forged Steel - Quenched and Tempered.
- Fatigue rated at 1-1/2 times the Working Load Limit at 20,000 cycles.
- Working Load Limits shown are for in-line pull. For angle loading, see page 202.
- Meets or exceeds all requirements of ASME B30.26 including identification, ductility, design factor, proof load and temperature requirements. Importantly, these bolts meet other critical performance requirements including fatigue life, impact properties and material traceability, not addressed by ASME B30.26.
- All Bolts Hot Dip galvanized after threading (UNC).
- Furnished with standard Hot Dip galvanized, heavy hex nuts.

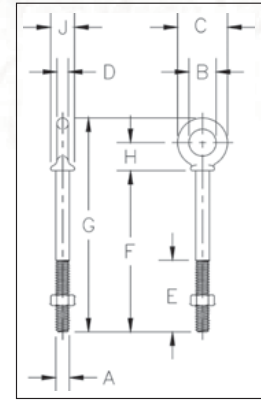

**Fatigue Rated**



### G-277 Shoulder Nut Eye Bolts

Shank Diameter & Length (mm)	G-277 Stock No.	Working Load Limit (t)*	Weight Per 100 (kg.)	Dimensions (mm)									
				A	B	C	D	E	F	G	H	J	
6.35 x 51.0	1045014	.29	2.99	6.35	12.7	22.4	4.85	38.1	51.0	74.5	12.7	11.9	
6.35 x 102	1045032	.29	4.13	6.35	12.7	22.4	4.85	63.5	102	125	12.7	11.9	
7.94 x 57.0	1045050	.54	5.67	7.85	15.7	28.4	6.35	38.1	57.0	89.0	17.5	14.2	
7.94 x 108	1045078	.54	8.53	7.85	15.7	28.4	6.35	63.5	108	140	17.5	14.2	
9.53 x 63.5	1045096	.70	9.71	9.65	19.1	35.1	7.85	38.1	63.5	101	19.8	16.8	
9.53 x 114	1045112	.70	11.5	9.65	19.1	35.1	7.85	63.5	114	152	19.8	16.8	
12.7 x 82.5	1045130	1.18	19.3	12.7	25.4	44.5	9.65	38.1	82.5	130	25.4	23.1	
12.7 x 152	1045158	1.18	25.8	12.7	25.4	44.5	9.65	76.0	152	200	25.4	23.1	
15.9 x 102	1045176	2.35	31.1	15.7	31.8	57.0	12.7	51.0	102	164	33.3	28.4	
15.9 x 152	1045194	2.35	46.4	15.7	31.8	57.0	12.7	76.0	152	214	33.3	28.4	
19.1 x 114	1045210	3.26	66	19.1	38.1	70.0	15.7	51.0	114	189	39.6	35.1	
19.1 x 152	1045238	3.26	76	19.1	38.1	70.0	15.7	76.0	152	227	39.6	35.1	
22.2 x 127	1045256	4.80	102	22.4	44.5	82.5	19.1	63.5	127	215	46.7	39.6	
25.4 x 152	1045292	6.03	166	25.4	51.0	95.5	22.4	76.0	152	253	53.0	46.0	
25.4 x 229	1045318	6.03	192	25.4	51.0	95.5	22.4	102	229	329	53.0	46.0	
31.8 x 203	1045336	9.52	295	31.8	63.5	114	25.4	102	203	323	62.5	58.0	
31.8 x 305	1045354	9.52	361	31.8	63.5	114	25.4	102	305	425	62.5	58.0	
38.1 x 381	1045372	10.8	646	38.1	76.0	140	31.8	152	381	527	76.0	70.0	

\*Ultimate Load is 5 times the Working Load Limit. Maximum Proof Load is 2 times the Working Load Limit.



**G-275**  
Screw Eye Bolts

- Forged Steel — Quenched and Tempered.
- Hot Dip galvanized.

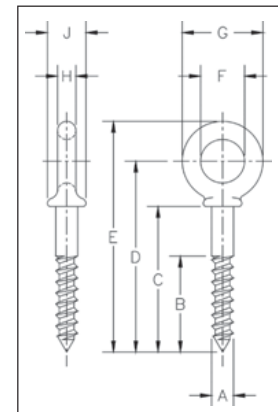

### G-275 Screw Eye Bolts

Shank Diameter & Length (mm)	G-275 Stock No.	Weight Per 100 (kg)	Dimensions (mm)									
			A	B	C	D	E	F	G	H	J	
6.35 x 51.0	1046111	1.95	6.35	38.1	51.0	63.5	74.5	12.7	22.4	4.83	11.9	
7.94 x 57.0	1046139	4.49	7.85	42.9	57.0	74.5	89.0	16.0	28.7	6.35	14.2	
9.53 x 63.5	1046157	8.56	9.65	47.8	63.5	83.5	101	19.1	35.1	7.87	16.8	
12.7 x 82.5	1046175	17.0	12.7	62.0	82.5	108	130	25.4	44.5	9.65	23.1	
15.9 x 102	1046193	38.8	16.0	76.0	102	135	164	31.8	57.0	12.7	28.4	



# Forged Machinery Eye Bolts



**S-279 / M-279**  
Shoulder Type  
Machinery Eye Bolts

- Forged Steel - Quenched & Tempered.
- Working Load Limits shown are for in-line pull. For angle loading, see page 202.
- Fatigue rated at 1-1/2 times the Working Load Limit at 20,000 cycles. traceability, not addressed by ASME B30.26.
- Recommended for in-line pull.
- S-279 threaded UNC.
- M-279 metric threaded.
- Meets or exceeds all requirements of ASME B30.26 including identification, ductility, design factor, proof load and temperature requirements. Importantly, these bolts meet other critical performance requirements including fatigue life, impact properties and material

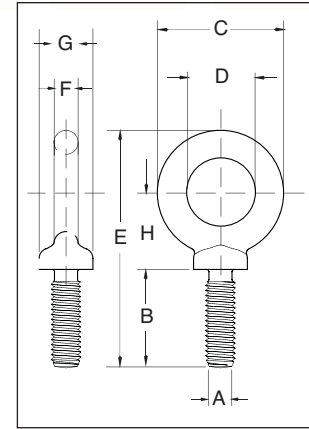

**Fatigue Rated**



## S-279 UNC Shoulder Type Machinery Eye Bolts

Size (mm)	S-279 Stock No.	Working Load Limit (t)*	Weight Each (kg)	Dimensions (mm)							
				A** Thread	B	C	D	E	F	G	H
6.35 x 25.4	9900182	.29	.02	1/4 - 20	25.9	28.7	19.1	58.0	4.85	13.5	19.6
7.94 x 28.6	9900191	.54	.04	5/16 - 18	29.2	35.1	22.4	69.5	6.35	15.0	24.1
9.53 x 31.8	9900208	.70	.06	3/8 - 16	32.3	41.1	25.4	78.0	7.85	17.5	26.7
12.7 x 38.1	9900217	1.18	.12	1/2 - 13	38.9	49.5	30.2	94.0	9.65	23.1	32.3
15.9 x 44.5	9900226	2.35	.24	5/8 - 11	45.5	60.5	35.1	113	12.7	28.7	38.9
19.1 x 51.0	9900235	3.26	.43	3/4 - 10	52.0	70.0	38.1	129	16.0	35.1	43.4
22.2 x 57.0	9900244	4.80	.70	7/8 - 9	58.5	82.5	44.5	149	19.1	39.6	50.8
25.4 x 63.5	9900253	6.03	1.1	1 - 8	65.5	95.5	51.0	169	22.4	46.0	58.4
28.5 x 70.0	9900257	6.80	1.5	1-1/8 - 7	69.8	107	57.1	183	24.6	52.3	59.7
31.8 x 76.0	9900262	9.52	1.8	1-1/4 - 7	78.5	114	63.5	202	25.4	58.0	69.3
38.1 x 89.0	9900271	10.8	3.2	1-1/2 - 6	91.5	140	76.0	241	31.8	70.0	83.3
44.5 x 95.0	9900280	15.4	4.7	1-3/4 - 5	95.2	159	88.9	266	35.0	76.2	91.4
51 x 102	9900289	19.0	8.6	2 - 4-1/2	102	194	101	313	46.0	85.9	114
63.5 x 127	9900298	29.5	14.5	2-1/2 - 4	127	223	114	378	53.8	108	140

\*Ultimate Load is 5 times the Working Load Limit. Maximum Proof Load is 2 times the Working Load Limit. \*\* All bolts threaded UNC.



## M-279 Metric

Size (mm)	M-279 Stock No.	Working Load Limit (t)*	Weight Each (kg.)	Dimensions (mm)							
				A** Thread	B	C	D	E	F	G	H
M6 x 13	1045753	.20	.03	M6 x 1.0	13.0	28.7	19.1	47.0	4.9	13.5	19.6
M8 x 13	1045789	.40	.05	M8 x 1.25	13.0	35.1	22.4	54.6	6.4	15.0	24.1
M10 x 17	1045833	.64	.07	M10 x 1.5	17.0	41.1	25.4	64.3	7.9	17.5	26.5
M12 x 20.5	1045869	1.0	.11	M12 x 1.75	20.5	49.5	30.2	77.7	9.7	23.1	32.8
M16 x 27	1045913	1.8	.25	M16 x 2.0	27.0	60.5	35.1	96.0	12.7	28.7	38.9
M20 x 30	1045995	2.5	.42	M20 x 2.5	30.0	70.0	38.1	108	16.0	35.1	43.4
M24 x 36	1046029	4.0	1.05	M24 x 3.0	36.0	95.5	51.0	142	22.4	46.0	58.4
M27 x 69.8	1046038	5.0	1.42	M27 x 3.0	69.8	107	57.1	183	24.6	52.3	59.7
M30 x 45	1046075	6.0	1.77	M30 x 3.5	45.0	114	63.5	171	25.4	58.0	69.3
M36 x 54	1046109	8.5	3.12	M36 x 4.0	54.0	140	76.0	207	31.8	70.0	83.3
M42 x 95.2	1046118	14.0	4.58	M42 x 4.5	95.2	159	88.9	266	35.0	76.2	91.4
M48 x 102	1046127	17.3	8.71	M48 x 5.0	102	194	101	313	46.0	85.9	114
M64 x 127	1046136	29.5	14.74	M64 x 6.0	127	223	114	378	53.8	108	140

\*Ultimate Load is 5 times the Working Load Limit. Maximum Proof Load is 2 times the Working Load Limit. \*\* On Request: Special threading or as forged bolts for customer conversion.

**RIGGING ACCESSORIES**



**S-293**  
Rivet Eye Bolt

- Forged steel - Quenched and Tempered.



## S-293 Rivet Eye Bolts

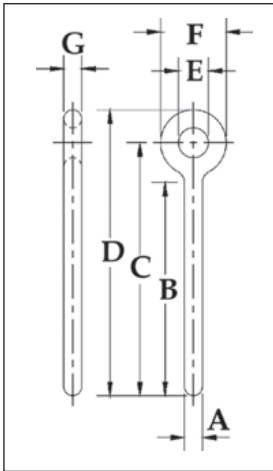

Shank Diameter & Length (mm)	S-293 Stock No.	Weight Per 100 (kg)	Dimensions (mm)						
			A	B	C	D	E	F	G
6.35 x 51.0	1043882	2.85	6.35	51.0	67.0	79.5	12.7	25.4	6.35
6.35 x 102	1043908	5.12	6.35	102	118	130	12.7	25.4	6.35
7.94 x 57.0	1043926	5.44	7.94	57.0	76.0	92.0	16.0	31.8	7.87
7.94 x 108	1043944	8.30	7.94	108	127	143	16.0	31.8	7.87
9.53 x 63.5	1043962	11.33	9.53	63.5	86.0	104	19.1	38.1	9.65
9.53 x 114	1043980	12.51	9.53	114	137	155	19.1	38.1	9.65
9.53 x 152	1044006	14.28	9.53	152	175	193	19.1	38.1	9.65
12.7 x 82.5	1044024	19.86	12.7	82.5	111	136	25.4	51.0	12.7
12.7 x 152	1044042	28.34	12.7	152	181	206	25.4	51.0	12.7
15.9 x 102	1044060	42.5	15.9	102	140	171	31.8	63.5	15.8
15.9 x 152	1044088	51.2	15.9	152	190	222	31.8	63.5	15.8
19.1 x 114	1044104	65.2	19.1	114	159	196	38.1	76.0	19.1
19.1 x 152	1044122	73.7	19.1	152	197	234	38.1	76.0	19.1
22.2 x 127	1044140	108	22.2	127	178	222	44.5	89.0	22.2
22.2 x 203	1044168	132	22.2	203	254	298	44.5	89.0	22.2
25.4 x 152	1044186	170	25.4	152	213	263	51.0	102	25.4
25.4 x 229	1044202	204	25.4	229	289	339	51.0	102	25.4
31.8 x 203	1044220	327	31.8	203	279	340	63.0	127	31.8
31.8 x 305	1044248	388	31.8	305	378	441	63.0	127	31.8



**S-276**  
Shoulder Rivet Eye Bolt

- Forged steel - Quenched and Tempered.



## S-276 Shoulder Rivet Eye Bolts

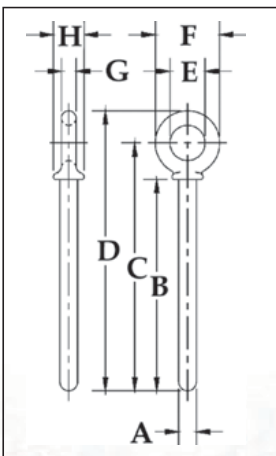

Shank Diameter & Length (mm)	S-276 Stock No.	Weight Per 100 (kg)	Dimensions (mm)							
			A	B	C	D	E	F	G	H
6.35 x 51.0	1045746	2.49	6.35	51.0	63.5	74.5	12.7	22.4	4.85	11.9
6.35 x 102	1045764	3.18	6.35	102	114	125	12.7	22.4	4.85	11.9
7.94 x 57.0	1045782	2.86	7.85	57.0	74.5	89.0	16.0	28.7	6.35	14.2
7.94 x 108	1045808	6.71	7.85	108	125	140	16.0	28.7	6.35	14.2
9.53 x 63.5	1045826	8.53	9.65	63.5	83.5	101	19.1	35.1	7.85	16.8
9.53 x 114	1045844	11.3	9.65	114	134	152	19.1	35.1	7.85	16.8
12.7 x 82.5	1045862	15.0	12.7	82.5	108	130	25.4	44.5	9.65	23.1
12.7 x 152	1045880	22.7	12.7	152	178	200	25.4	44.5	9.65	23.1
15.9 x 102	1045906	31.2	16.0	102	135	164	31.8	57.0	12.7	28.4
15.9 x 152	1045924	34.0	16.0	152	186	214	31.8	57.0	12.7	28.4
19.1 x 114	1045942	57	19.1	114	154	189	38.1	70.0	15.7	35.1
19.1 x 152	1045960	68	19.1	152	192	227	38.1	70.0	15.7	35.1
22.2 x 127	1045988	91	22.4	127	174	215	44.5	82.5	19.1	39.6
25.4 x 152	1046022	135	25.4	152	205	253	51.0	95.5	22.4	46.0
25.4 x 229	1046040	193	25.4	229	282	329	51.0	95.5	22.4	46.0
31.8 x 203	1046068	297	31.8	203	266	323	63.5	114	25.4	58.0
31.8 x 305	1046086	323	31.8	305	368	425	63.5	114	25.4	58.0
38.1 x 381	1046102	646	38.1	381	457	527	76.0	140	31.8	70.0



# Ring Bolts -Pad Eyes



- Forged Steel - Quenched and Tempered.
- Hot Dip galvanized.
- All Bolts Hot Dip galvanized after threading.
- Diameter of ring stock is same as shank diameter.

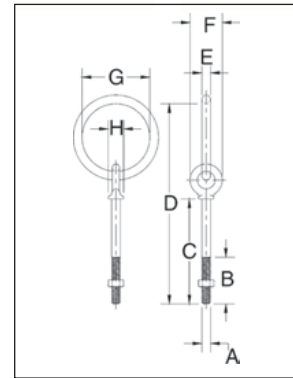

**G-257**  
Shoulder Nut  
Ring Bolts



## G-257 Shoulder Nut Ring Bolts

Ring Bolt Size (mm)	G-257 Stock No.	Working Load Limit (t)*	Weight Per 100 (kg)	Dimensions (mm)							
				A	B	C	D	E	F	G	H
9.53 X 114	1046335	.54	25.7	9.65	63.5	114	195	9.70	35.1	51.0	16.8
12.7 X 152	1046371	1.00	45.4	12.7	76.0	152	254	12.7	44.5	63.5	23.1

\*Ultimate Load is 5 times the Working Load Limit.



**S-264**  
Pad Eye

- Forged Steel — Quenched and Tempered.
- Forged from 1035 Carbon Steel.
- Excellent welding qualities.
- Widely used on farm machinery, trucks, steel hulled marine vessels and material handling equipment.
- Reference American Welding Society specifications for proper welding procedures.

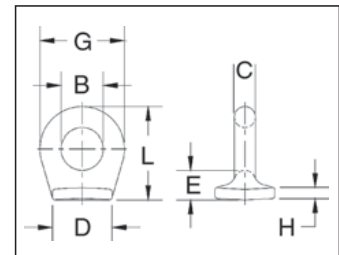

## S-264 Pad Eyes

Size No.*	S-264 Stock No.	Weight Per 100 (kg)	Dimensions (mm)						
			B	C	D	E	G	H	L
* 0	1090722	1.27	6.35	4.85	16.0	7.85	16.0	2.30	19.1
* 1	1090740	2.95	9.65	6.35	22.4	10.4	22.4	3.30	26.2
* 1.5	1090768	4.72	16.0	6.35	25.4	11.2	28.7	4.05	33.3
2	1090786	9.57	19.1	9.65	26.9	12.7	38.1	4.85	41.4
4	1090802	23.7	25.4	14.2	36.6	19.8	54.0	5.60	59.5
5	1090820	37.4	31.8	17.5	44.5	20.6	67.0	6.35	70.0

\*Meets the requirements of Military Specification MS-51930A.

**RIGGING ACCESSORIES**

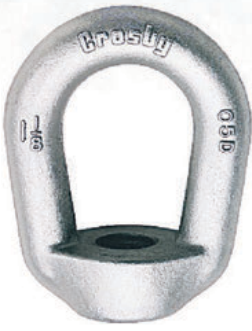

**G-400**  
Eye Nut

- Forged Steel - Quenched and Tempered.
- Hot Dip galvanized.
- Tapped with standard UNC class 2 threads after galvanizing.
- Also available in blank (as forged) item (S-4028) or on request with metric threading ( M-400).
- Recommended for In-Line pull.
- Meets or exceeds all requirements of ASME B30.26 including identification, ductility, design factor, proof load and temperature requirements. Importantly, these products meet other critical performance requirements including fatigue life, impact properties and material traceability, not addressed by ASME B30.26.

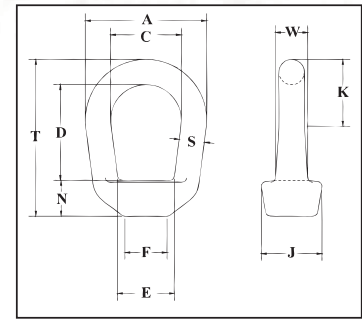

## G-400 Eye Nuts

Size No.	"S" Stock Size (mm)	G-400 Stock No	Std. Tap Size (in.)	Working Load Limit (t)*	Weight Each (kg)	Dimensions (mm)									
						A	C	D	E	F	J	K	N	T	W
1	6.35	1090438	1/4	.24	.04	31.8	19.1	25.4	19.1	12.7	17.5	16.0	9.65	43.7	7.85
2	7.85	1090474	3/8	.57	.08	41.1	25.4	30.5	21.1	14.2	20.6	22.6	12.7	53	10.4
3A	9.65	1090517	1/2	1.02	.13	51.0	31.8	36.6	27.4	20.6	25.4	27.7	15.7	63.5	12.7
4	12.7	1090535	5/8	1.63	.27	63.5	38.1	48.8	34.3	25.4	33.3	33.3	17.5	82.5	17.5
5	16	1090553	3/4	2.36	.45	76.0	44.5	60.5	40.4	28.4	38.1	39.9	22.4	98.8	21.3
6	19.1	1090571	7/8	3.27	.75	89.0	51.0	66.8	49.8	35.1	47.8	45.0	23.9	110	25.4
7	22.4	1090599	1	4.54	1.22	102	57.0	77.7	56.0	39.6	54.0	51.5	27.2	127	30.2
8	25.4	1090633	1-1/4	7.03	1.98	114	63.5	88.9	62.5	47.8	60.5	57.5	31.8	147	35.1
9	28.7	1090651	1-3/8	8.39	2.27	127	70.0	102	68.5	51.0	65.0	64.5	35.1	165	38.1
10	31.8	1090679	1-1/2	10.21	3.08	143	79.0	109	78.5	57.0	76.0	71.5	38.1	179	42.2
11	38.1	1090697	2	18.14	6.62	181	104	157	104	79.5	95.5	93.5	52.3	252	49.3

\*Working Load Limit shown is for In-Line pull. Ultimate Load is 5 times the Working Load Limit. Rating based on standard tap size.



**S-405**  
Lifting Eye

- Forged Steel — Quenched and Tempered.
- On request: threaded to customer specification.

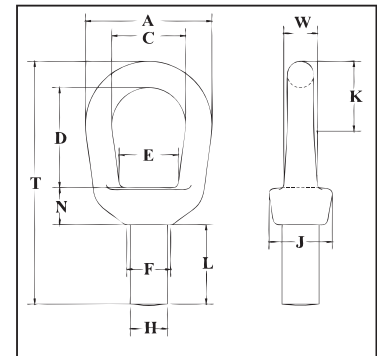

## S-405 Lifting Eyes

Size No.	S-405 Stock No.	Working Load Limit Threaded (t)*	Maximum Thread Diam. (mm)	Weight Each (kg)	Dimensions (mm)											
					A	C	D	E	F	H †	J	K	L	N	T	W
1	1090269	.39	7.85	.05	31.8	19.1	25.9	16.8	12.7	8.65	17.5	17.0	17.5	10.7	62.5	7.85
2	1090287	.57	9.65	.09	41.1	25.4	30.5	19.1	14.2	10.4	20.6	23.4	23.9	14.0	76	10.4
3	1090303	1.02	12.7	.23	51.0	31.8	36.6	25.4	20.6	13.5	28.7	28.7	31.8	17.3	93.5	12.7
4	1090321	1.63	16.0	.36	63.5	38.1	48.8	30.2	25.4	16.8	33.3	35.1	38.1	20.3	116	17.5
5	1090349	2.36	19.1	.57	76.0	44.5	58.0	35.1	28.4	19.8	38.1	42.2	44.5	24.9	140	21.3
6	1090367	3.27	22.4	1.02	89.0	51.0	63.5	41.4	35.1	23.1	47.8	48.5	47.8	26.9	156	25.4
7	1090385	4.54	25.4	1.47	102	57.0	74.0	47.8	39.6	26.2	54.0	55.0	52.5	30.5	179	30.2
8	1090401	5.67	28.7	2.13	114	63.5	85.0	49.3	47.8	29.5	60.5	62.5	63.5	35.6	207	35.1
10	1090410	8.16	38.1	4.23	143	79.0	97.0	70.0	57.0	38.9	76.0	75.5	81.5	42.9	252	42.2

\*Ultimate Load is 5 times the Working Load Limit. Rating based on UNC thread size shown in Max Thread Diameter column. † Dimension before machining (as forged).



# Crosby Bundle Clip



**G-460**  
Soft Eye  
Bundle Clip  
(For use without Thimble)

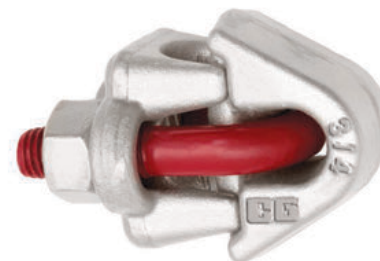

**G-461**  
Thimble  
Eye Bundle Clip

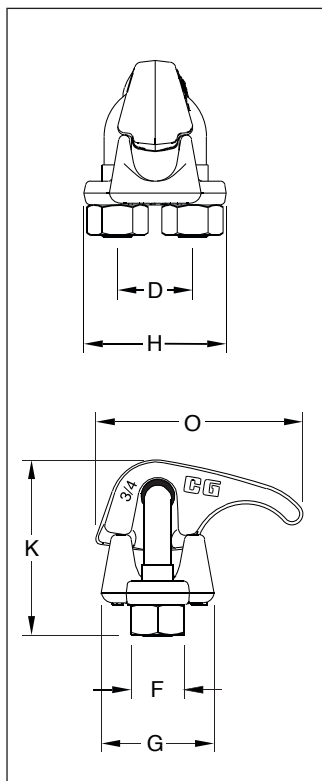

- Each base and Bundle Clip adapter has a Product Identification Code (PIC) for material tracability, the name Crosby or CG, and a size forged into it.
- Entire clip galvanized to resist corrosive and rusting action.
- Forged bases and bundle clip adapters.
- All bundle clips are individually bagged or tagged with proper application instructions and warning information.
- Clips have rolled threads.
- Bundle Clip Adapter for Soft Eye (G4460) and for Thimble Eye (G4461) kits available.
- Look for the Red-U-Bolt, your assurance of Genuine Crosby Products.
- Meets or exceeds all requirements of ASME B30.26 including manufacturing I.D. and size requirements. Importantly, these wire rope bundle clips meet material traceability not addressed by ASME B30.26.

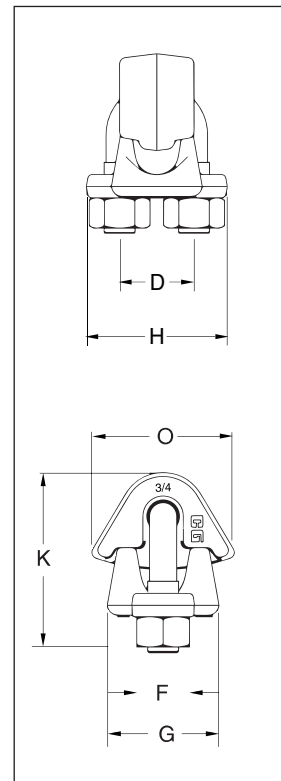

## G-460 Soft Eye / G-461 Thimble Eye Bundle Clip

Rope Size		Bundle Clip Style	Stock No.	Dimensions (mm)						Weight each (kg)
(mm)	(in.)			D	F	G	H	K	O	
18-20	3/4	G460	1010509	38.1	26.9	57.2	72.1	88.9	105	1.1
18-20	3/4	G461	1010619	38.1	26.9	57.2	72.1	88.9	72.4	1.1



# Swivel Hoist Ring



**HR-125M**  
Swivel Hoist Ring

Color coded to distinguish between UNC (Red) and Metric (Silver) thread types.



**HR-125**  
Swivel Hoist Ring

- Available in UNC and Metric thread sizes.
  - UNC threads available in sizes from 800 pounds to 100,000 pounds Working Load Limit, with a design factor of 5 to 1.
  - Metric threads available in sizes from 400kg to 16,900kg and dual rated in both a 4 to 1 and 5 to 1 design factor.
- All Components are Alloy Steel - Quenched and Tempered.
- Rated at 100% at 90° angle.
- 100% individually proof tested to 2-1/2 times the Working Load Limit with certification and Statistically Magnetic Particle inspected. (Can be furnished 100% Magnetic Particle inspected when requested at time of order.)
- Each product has a Product Identification Code (PIC) for material traceability along with a Working Load Limit and the name Crosby or "CG" stamped into it.
- 360° swivel and 180° pivot action.
- Fatigue rated to 20,000 cycles at 1-1/2 times the Working Load Limit.
- Individually packaged along with proper application instructions and warning information.
- Bolt is secured with E-clip, threads are grooved. This method allows for easy disassembly and assembly of hoist ring for thorough examination of all components. Replacement kits are available.
- Bolts are individually Proof Tested.
- Multiple Bolt length available to meet specific application requirements.
- Zinc Plated (Yellow Chromate) finish for increased corrosion protection thru 30,000 pound size.
- Meets or exceeds all the requirements of ASME B30.26 including identification, ductility, design factor, proof load and temperature requirements. Importantly, these hoist rings meet other critical performance requirements including fatigue life, impact properties and material traceability, not addressed by ASME B30.26.



**Fatigue Rated**



**Load Rated**



Scan this QR code with your smart device to view our Eye Bolts & Hoist Rings video.



# UNC Swivel Hoist Rings



**HR-125**  
Swivel Hoist Ring

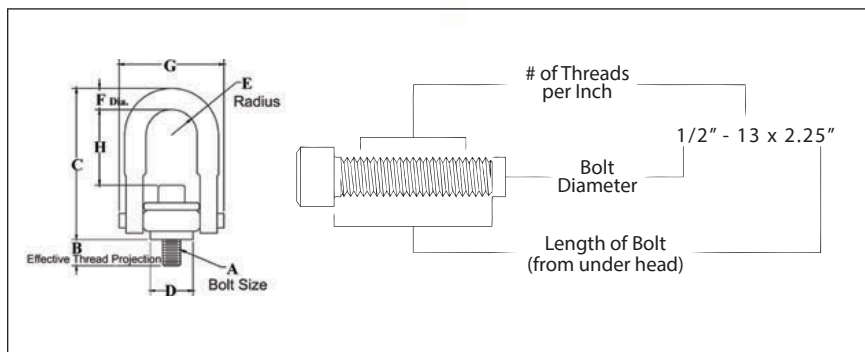

- Top washer has the following features:
  - The Working Load Limit and Recommended Torque value are permanently stamped into each washer.
  - Washer is color coded for easy identification: Red - UNC thread.
- Individually Proof Tested to 2-1/2 times Working Load Limit.
- Bolt specification is an Alloy socket head cap screw to ASTM A 574.
- All threads listed are UNC.
- **BOLT SIZE IDENTIFICATION:** The size of the bolt will be stated as in the drawing above. Illustration shows meaning of each dimension given.
- NOTE: For Special Applications, see page 457.
- Frame 2 and larger are **RFID EQUIPPED**.

**Fatigue Rated**



**Load Rated**

**SEE APPLICATION AND WARNING INFORMATION**  
On Pages 210 - 211  
Para Español: [www.thecrosbygroup.com](http://www.thecrosbygroup.com)

## HR-125 UNC Threads

Frame Size (mm)	HR-125 Stock No.	Working Load Limit (kg)*	Torque (Nm)	Bolt Size A ‡ (in.)	Dimensions (mm)							Weight Each (kg.)
					Effective Thread Projection Length B	C	D	Radius E	Diameter F	G	H	
1 †	1016887	363	10	5/16 - 18 x 1.50	14.7	69.1	24.6	11.7	8.60	47.5	28.4	.17
1 †	1016898	454	16	3/8 - 16 x 1.50	14.7	69.1	24.6	11.7	8.60	47.5	26.7	.18
2	1016909	1134	38	1/2 - 13 x 2.00	17.8	123	49.8	22.1	19.0	85.1	58.2	1.06
2 †	1016912	1134	38	1/2 - 13 x 2.50	30.5	123	49.8	22.1	19.0	85.1	58.2	1.07
2	1016920	1814	81	5/8 - 11 x 2.00	17.8	123	49.8	22.1	19.0	85.1	54.9	1.09
2 †	1016924	1814	81	5/8 - 11 x 2.75	36.8	123	49.8	22.1	19.0	85.1	54.9	1.12
2	1016931	2268	136	3/4 - 10 x 2.25	24.1	123	49.8	22.1	19.0	85.1	51.8	1.14
2 †	1016935	2268	136	3/4 - 10 x 2.75	36.8	123	49.8	22.1	19.0	85.1	51.8	1.17
3	1016942	3175**	136	3/4 - 10 x 2.75	22.6	167	75.2	34.5	23.9	124	75.4	3.05
3 †	1016946	3175**	136	3/4 - 10 x 3.50	41.7	167	75.2	34.5	23.9	124	75.4	3.09
3	1016953	3629	217	7/8 - 9 x 2.75	22.6	167	75.2	34.5	23.9	124	72.1	3.10
3 †	1016957	3629	217	7/8 - 9 x 3.50	41.7	167	75.2	34.5	23.9	124	72.1	3.16
3	1016964	4536	312	1 - 8 x 3.00	29.0	167	75.2	34.5	23.9	124	69.1	3.22
3 †	1016969	4536	312	1 - 8 x 4.00	54.4	167	75.2	34.5	23.9	124	69.1	3.32
4	1016975	6804	637	1-1/4 - 7 x 4.50	56.1	221	94.2	44.5	30.2	157	99.8	6.58
5	1016986	10890	1085	1-1/2 - 6 x 6.50	3.0	315	120	60.7	44.5	215	143	17.1
5	1016997	13610	1491	2 - 4-1/2 x 6.50	3.0	315	120	60.7	44.5	215	131	18.5
6	1017001	22680	2847	2-1/2 - 4 x 8.0	102	429	146	76.2	57.2	279	204	39.9
7	1017005	34020	5830	3 - 4 x 10.5	127	495	184	95.3	69.9	360	216	75.3
8	1017009	45360	6915	3-1/2 - 4 x 13.0 #	178	561	197	102	82.6	404	236	120

\*Ultimate Load is 5 times the Working Load Limit.

\*\* Ultimate Load is 4.5 times the Working Load Limit for 317.5 kg Hoist Ring when tested in 90 degree orientation.

† Long Bolts are designed to be used with soft metal (i.e., aluminum) workpiece. While the long bolts may also be used with ferrous metal (i.e., steel & iron) workpiece, short bolts are designed for ferrous workpieces only.

‡ Bolt specification is an Alloy socket head cap screw to ASTM A 574.

# Hex head bolt used on Frame 8 (100,000lb.) Hoist Ring.

**RIGGING ACCESSORIES**



**HR-125M**  
Swivel Hoist Ring

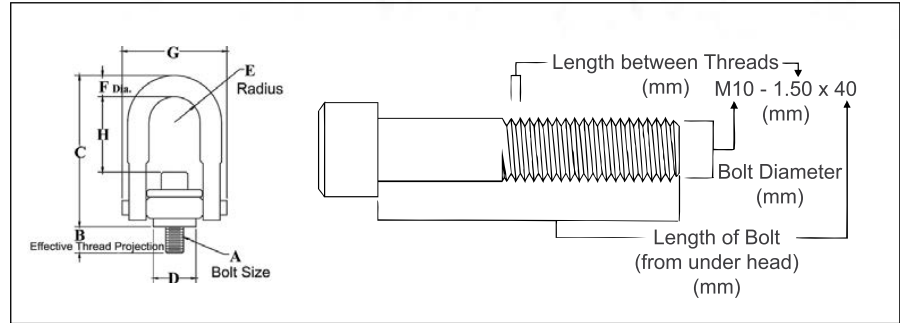

- Top washer has the following features:
  - The Working Load Limit and Recommended Torque value are permanently stamped into each washer.
  - Washer is color coded for easy identification: Silver - Metric thread.
- Individually Proof Tested to 2-1/2 times Working Load Limit.
- Bolt specification is a Grade 12.9 Alloy socket head cap screw to Din 912. All threads listed are metric (ASME B18.3.1m).
- Designed to be used with ferrous workpiece only.
- BOLT SIZE IDENTIFICATION: The size of the bolt will be stated as in the drawing above. Illustration shows meaning of each dimension given.
- NOTE: For Special Applications, see page 457.
- Frame 2 and larger RFID EQUIPPED.



**Fatigue Rated**



**Load Rated**



## HR-125M Metric Threads

Frame Size No.	HR-125M Stock No.	Working Load Limit (kg)		Torque (Nm)*	Dimensions (mm)								Weight Each (kg)
		At a 5:1 Design Factor †	At a 4:1 Design Factor †		(A) Bolt Size ‡	(B) Effective Thread Projection Length	C	D	Radius E	Diameter F	G	H	
1	1016602	400	500	10	M8X1.25X40	16.9	69.9	24.6	11.8	8.5	47.5	29.9	.17
1	1016613	450	550	16	M10X1.50X40	16.9	69.9	24.6	11.8	8.5	47.5	28.1	.18
2	1016624	1050	1300	38	M12X1.75X50	16.9	123	49.8	22.3	17.5	85.1	60.4	1.05
2	1016635	1900	2400	81	M16X2.00X60	26.9	123	49.8	22.3	17.5	85.1	56.3	1.11
2	1016644	2150	2700	136	M20X2.50X65	31.9	123	49.8	22.3	17.5	85.1	52.3	1.17
3	1016657	3000	3750	136	M20X2.50X75	27.8	167	75.2	34.7	25.4	124	76.6	3.09
3	1016668	4200	5250	312	M24X3.00X80	32.8	167	75.2	34.7	25.4	124	70.5	3.21
4	1016679	7000	8750	637	M30X3.50X120	61.7	222	94.2	44.5	30.5	157	102	6.53
5	1016690	11000	13750	1005	M36X4.00X150	54.0	318	120	60.7	44.5	215	142	16.8
5	1016701	12500	15600	1005	M42X4.50X160	64.0	318	120	60.7	44.5	215	136	17.4
5	1016712	13500	16900	1350	M48X5.00X160	74.0	318	120	60.7	44.5	215	130	18.0

\*The tightening torque values shown are based upon threads being clean, dry and free of lubrication.  
 † Individually proof loaded to 2-1/2 times the Working Load Limit based on the 4:1 design factor.  
 ‡ Bolt specification is a Grade 12.9 Alloy socket head cap screw to Din 912. All threads are metric (ASME/ANSI B18.3.1m).

# Heavy Lift Swivel Hoist Rings



HR-1000

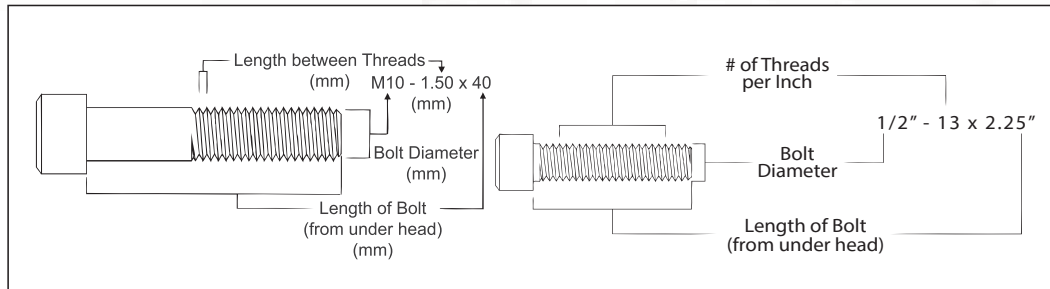

- Forged bail provides the following:
  - Easily readable "Raised Lettering" showing the name Crosby or "CG" and PIC Code for material traceability.
  - Greater durability providing the increased "Toughness" desired in potentially abusive field conditions.
  - Larger opening than standard Hoist Ring bail.
- Top washer is color coded for easy identification (Red for UNC threads and Silver for Metric threads)
- The Working Load Limit and Recommended Torque value are permanently stamped into each washer.
- Individually Proof Tested to 2-1/2 times Working Load Limit.
- Available in both UNC Thread and Metric Thread style.
- **BOLT SIZE IDENTIFICATION:** The size of the bolt will be stated as in the drawing below. Illustration shows meaning of each dimension given.
- **NOTE:** For Special Applications, see page 449.
- Frame 2 and larger are **RFID EQUIPPED**.

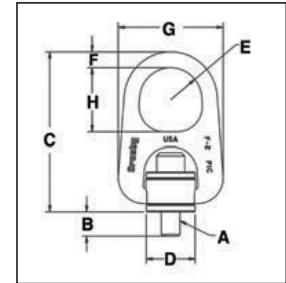

**Fatigue Rated**



**Load Rated**



## HR-1000 UNC Threads

Frame Size No.	HR-1000 Stock No.	Working Load Limit (kg)*	Torque (Nm)	Bolt Size A ‡ (in.)	Dimensions (mm)								Weight Each (kg.)
					Eff. Thread Projection Length B	C	D	Radius E	Diameter F	G	H		
1	1068002	363	10	5/16 - 18 x 1.50	13.2	93.7	24.6	15.7	11.2	57.7	35.1	.27	
1	1068006	454	16	3/8 - 16 x 1.50	13.2	93.7	24.6	15.7	11.2	57.7	35.1	.28	
2	1068010	1134	38	1/2 - 13 x 2.25	17.5	159	49.8	31.8	15.7	107	63.5	1.38	
2 †	1068014	1134	38	1/2 - 13 x 2.75	30.2	159	49.8	31.8	15.7	107	63.5	1.39	
2	1068018	1814	81	5/8 - 11 x 2.25	17.5	159	49.8	31.8	15.7	107	63.5	1.41	
2 †	1068022	1814	81	5/8 - 11 x 3.00	36.6	159	49.8	31.8	15.7	107	63.5	1.44	
2	1068026	2268	136	3/4 - 10 x 2.50	23.9	159	49.8	31.8	15.7	107	63.5	1.47	
2 †	1068030	2268	136	3/4 - 10 x 3.00	36.6	159	49.8	31.8	15.7	107	63.5	1.50	
3	1068034	3175**	136	3/4 - 10 x 3.00	21.6	220	75.2	41.4	25.4	159	82.6	4.58	
3 †	1068038	3175**	136	3/4 - 10 x 3.50	34.3	220	75.2	41.4	25.4	159	82.6	4.63	
3	1068042	3629	217	7/8 - 9 x 3.00	21.6	220	75.2	41.4	25.4	158	82.6	4.63	
3 †	1068046	3629	217	7/8 - 9 x 3.50	34.3	220	75.2	41.4	25.4	158	82.6	4.71	
3	1068050	4536	312	1 - 8 x 3.50	34.3	220	75.2	41.4	25.4	158	82.6	4.76	
3 †	1068054	4536	312	1 - 8 x 4.50	59.7	220	75.2	41.4	25.4	158	82.6	4.86	
4	1068058	6804	637	1-1/4 - 7 x 5.00	53.1	285	94.2	50.8	31.8	199	102	9.93	
4	1068062	10890	1085	1-1/2 - 6 x 5.50	65.8	285	94.2	50.8	31.8	199	102	10.4	

## HR-1000M Metric Threads

Frame Size No.	HR-1000M Stock No.	Working Load Limit (kg)*		Torque (Nm)	Bolt Size A ‡	Dimensions (mm)								Weight Each (kg)
		At a 5:1 Design Factor***	At a 4:1 Design Factor***			Eff. Thread Projection Length B	C	D	Radius E	Diameter F	G	H		
1	1068307	400	500	10	M8 x 1.25 x 40	15.2	93.7	24.6	15.7	11.2	57.7	35.1	.3	
1	1068316	450	550	16	M10 x 1.50 x 40	15.2	93.7	24.6	15.7	11.2	57.7	35.1	.3	
2	1068325	1050	1300	38	M12 x 1.75 x 55	15.5	162	49.8	31.8	19.1	107	63.5	1.5	
2	1068334	1900	2400	81	M16 x 2.00 x 65	25.5	162	49.8	31.8	19.1	107	63.5	1.5	
2	1068343	2150	2700	136	M20 x 2.50 x 70	30.5	162	49.8	31.8	19.1	107	63.5	1.6	
3	1068352	3000	3750	136	M20 x 2.50 x 80	25.4	220	75.2	41.4	25.4	159	82.6	4.6	
3	1068361	4200	5250	312	M24 x 3.00 x 90	35.4	220	75.2	41.4	25.4	159	82.6	4.8	
4	1068370	7000	8750	637	M30 x 3.50 x 140	66.2	285	94.2	50.8	31.8	199	102	9.7	
4	1068389	11000	13750	1005	M36 x 4.00 x 130	56.2	285	94.2	50.8	31.8	199	102	10.2	

\*Ultimate Load is 5 times the Working Load Limit. \*\* Ultimate Load is 4.5 times the Working Load Limit for 317.5 kg Hoist Ring when tested in 90 degree orientation. \*\*\* Individually proof loaded to 2-1/2 times the Working Load Limit based on the 4:1 design factor. † Long Bolts are designed to be used with soft metal (i.e., aluminum) workpiece. While the long bolts may also be used with ferrous metal (i.e., steel & iron) workpiece, short bolts are designed for ferrous workpieces only. ‡ Bolt specification is an Alloy socket head cap screw to ASTM A 574. †† Bolt specification is a Grade 12.9 Alloy socket head cap screw to DIN 912. NOTE: The tightening torque values shown are based upon threads being clean, dry and free of lubrication.



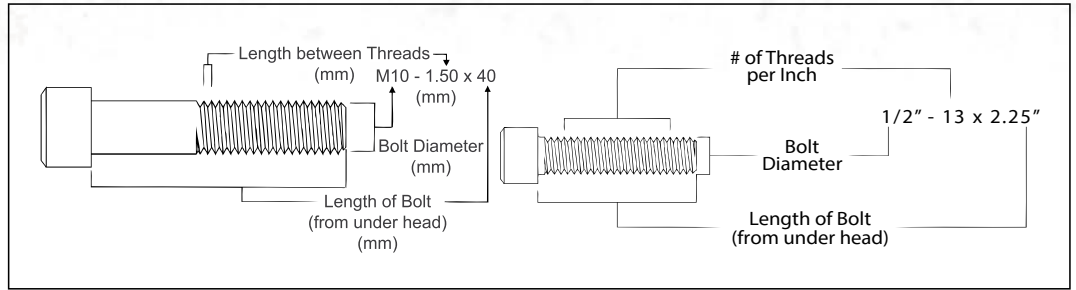

## HR-1000CT

- All load bearing components are heat treated, Quenched & Tempered alloy steel.
- All components, with the exception of the retaining ring, are produced with maximum material hardness of 34 HRc. All primary load bearing components have charpy impact testing. The body, bushing, washer and bail meet impact requirements of 31 ft-lbs min. avg. at -4°F. The bolt meets impact requirements of 20 ft-lbs min. avg. at -150°F.
- Individually Mag inspected with certification.
- Forged bail provides the following:
  - Easily readable raised lettering showing the name Crosby or "CG" and PIC Code for material traceability.
  - Greater durability providing the increased "Toughness" desired in potentially abusive field conditions.
  - Larger opening than standard Hoist Ring bail.
- Top washer is color coded for easy identification (blue for UNC threads and grey for Metric threads).
- The Working Load Limit and Recommended Torque value are permanently stamped into each washer.
- Individually Proof Tested to 2 times Working Load Limit (90° and in-line).
- **BOLT SIZE IDENTIFICATION:** The size of the bolt will be stated as in the drawing above. Illustration shows meaning of each dimension given.
- **NOTE:** For Special Applications, see page 457.
- Frame 2 and larger are **RFID EQUIPPED**.
- Individually serialized.
- 100% MPI all primary load bearing components.
- Coating: Thermo-diffusion galvanized.
- Optional bolt sizes available upon request.

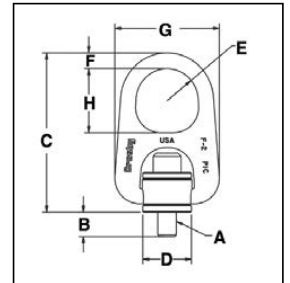

**Fatigue Rated**



**Load Rated**

**SEE APPLICATION AND WARNING INFORMATION**  
 On Pages 210 - 211  
 Para Español: www.thecrosbygroup.com

## HR-1000CT UNC Threads

Frame Size No.	HR-1000CT Stock No.	Working Load Limit (kg)*	Torque (Nm)	Dimensions (mm)								Mass Each (kg)
				Bolt Size A ‡	Eff. Thread Projection Length B	C	D	Radius E	Diameter F	G	H	
2	6608103	862	38	1/2 - 13 x 2.25	17.8	161	49.8	31.8	19.1	107	63.5	1
2	6608112	862	38	1/2 - 13 x 2.75	30.5	161	49.8	31.8	19.1	107	63.5	1
2	6608121	1361	81	5/8 - 11 x 2.25	17.8	161	49.8	31.8	19.1	107	63.5	1
3	6608130	2177	136	3/4 - 10 x 3.00	21.6	218	75.2	41.4	25.4	159	82.6	5
3	6608139	2812	217	7/8 - 9 x 3.00	21.6	218	75.2	41.4	25.4	159	82.6	5
3	6608148	3765	312	1 - 8 x 3.50	34.3	218	75.2	41.4	25.4	159	82.6	5
4	6608149	5670	637	1-1/4 - 7 x 5.00	53.3	287	94.2	50.8	36.6	207	102	11
4	6607669	9072	1085	1-1/2 - 6 x 5.50	66.0	287	94.2	50.8	36.6	207	102	12
4	6607727	9072	1085	1-1/2 - 8 x 5.50	66.0	287	94.2	50.8	36.6	207	102	12
5	6607670	12701	1491	2 - 4.5 x 7.50	81.3	385	102	68.3	44.5	296	127	31
6	6607671	20412	2847	2 1/2 - 4 x 9.50	94.7	506	146	76.2	69.9	368	143	71

\*Ultimate Load is 5 times the Working Load Limit. ‡ Bolt specification is an Alloy socket head cap screw to ASTM A320 Grade L7 or L43.  
 NOTE: The tightening torque values shown are based upon threads being clean, dry and free of lubrication.

# Heavy Lift Swivel Hoist Rings

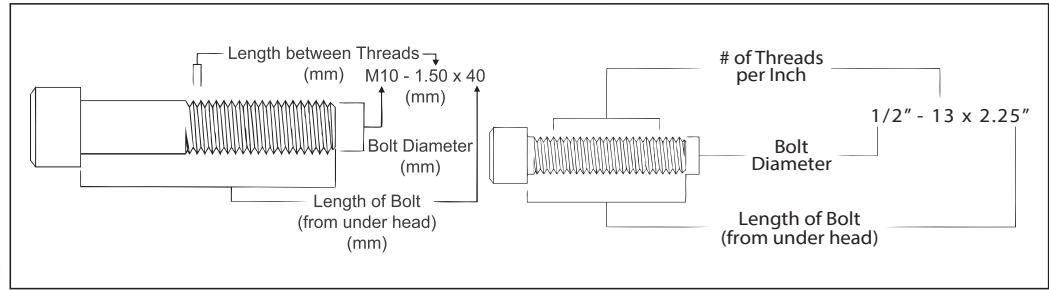

**HR-1000MCT**

- All load bearing components are heat treated, Quenched & Tempered alloy steel.
- All components, with the exception of the retaining ring, are produced with maximum material hardness of 34 HRC. All primary load bearing components have Charpy impact testing. The body, bushing, washer and bail meet impact requirements of 31 ft-lbs min. avg. at -4°F. The bolt meets impact requirements of 20 ft-lbs min. avg. at -150°F.
- Individually Mag inspected with certification.
- Forged bail provides the following:
  - Easily readable raised lettering showing the name Crosby or "CG" and PIC Code for material traceability.
  - Greater durability providing the increased "Toughness" desired in potentially abusive field conditions.
  - Larger opening than standard Hoist Ring bail.
- Top washer is color coded for easy identification (blue for UNC threads and grey for Metric threads).
- The Working Load Limit and Recommended Torque value are permanently stamped into each washer.
- Individually Proof Tested to 2 times Working Load Limit (90° and in-line).
- **BOLT SIZE IDENTIFICATION:** The size of the bolt will be stated as in the drawing above. Illustration shows meaning of each dimension given.
- **NOTE:** For Special Applications, see page 457.
- Frame 2 and larger are **RFID EQUIPPED**.
- Individually serialized.
- 100% MPI all primary load bearing components.
- Coating: Thermo-diffusion galvanized.
- Optional bolt sizes available upon request.

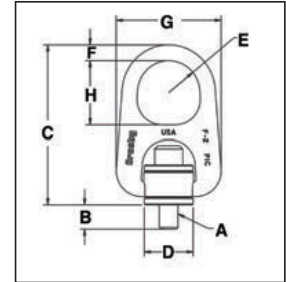

**Fatigue Rated**



**Load Rated**

**SEE APPLICATION AND WARNING INFORMATION**  
On Page 210 -211  
Para Español: www.thecrosbygroup.com

## HR-1000MCT Metric Threads

Frame Size No.	HR-1000MCT Stock No.	Working Load Limit (kg)*		Torque (Nm)	Dimensions (mm)								Mass Each (kg.)
		Design Factor 5:1	Design Factor 4:1		Bolt Size A ‡	Eff. Thread Projection Length B	C	D	Radius E	Diameter F	G	H	
2	6630058	825	1,030	38	M12 x 1.75 x 55	15.6	160.6	49.7	31.8	19.1	106.7	63.5	1
2	6630059	1,350	1,690	81	M16 x 2.00 x 65	25.5	160.6	49.7	31.8	19.1	106.7	63.5	1
3	6630060	2,250	2,810	136	M20 x 2.50 x 80	25.3	218.2	75.1	41.4	25.4	158.8	82.6	5
3	6630061	3,175	3,970	312	M24 x 3.00 x 90	35.4	218.2	75.1	41.4	25.4	158.8	82.6	5
4	6630062	5,450	6,810	637	M30 x 3.50 x 140	65.9	287.3	94.1	50.8	36.6	206.5	101.6	11
4	6630063	7,450	9,310	1,005	M36 x 4.00 x 130	56.3	287.3	94.1	50.8	36.6	206.5	101.6	12
5	6630064	13,250	16,560	1,350	M46 x 5.00 x 180	50.7	384.9	101.6	68.3	44.5	295.6	127.0	30

\*Ultimate Load is 5 times the Working Load Limit. ‡ Bolt specification is an Alloy socket head cap screw to ASTM A320 Grade L7 or L43.  
NOTE: The tightening torque values shown are based upon threads being clean, dry and free of lubrication.

**RIGGING ACCESSORIES**

# Stainless Steel Swivel Hoist Rings



**SS-125UNC**

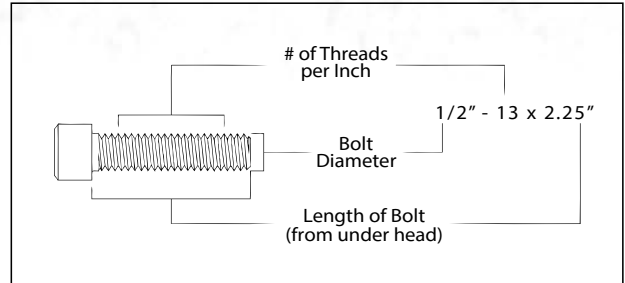
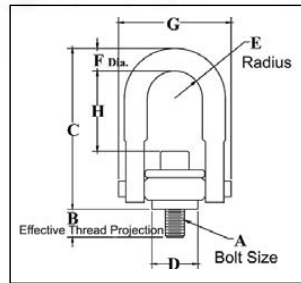

- All components are 316 stainless steel, except bolt retainers, which are made from 15-7 PH (UNS 15700) magnetic stainless steel.
- Available in capacities from 200 kg to 22,300 kg.
- Rated at 100 percent at 90 degree angle.
- Each product has a Product Identification Code (PIC) for material traceability, along with the Working Load Limit and the name Crosby or "CG" stamped into it.
- Individually proof tested to 2 times the Working Load Limit with certification.
- Fatigue Rated to 20,000 cycles at 1-1/2 times the Working Load Limit.
- Washer is color coded for easy identification (Red - UNC thread).
- Bolt specification is 316 Stainless Steel socket head cap screw to ASTM F 837M (316).
- All threads listed are Metric (ASME/ANSI B18.3.1M).
- **BOLT SIZE IDENTIFICATION:** The size of the bolt will be stated as in the drawing above. Illustration shows meaning of each dimension given.
- **NOTE:** For Special Applications, see page 457.
- Frame 2 and larger are **RFID EQUIPPED**.

**Fatigue Rated**



**Load Rated**

**SEE APPLICATION AND WARNING INFORMATION**  
 On Pages 210 -211  
 Para Español: www.thecrosbygroup.com

## SS-125UNC Threads

Frame Size No.	SS-125UNC Stock No.	Working Load Limit (kg)*	Torque (Nm)	Bolt Size A ‡	Effective Thread Projection Length B	Dimensions (mm)						Weight Each (kg.)
						C	D	Radius E	Diameter F	G	H	
1	1065000	400	3.5	5/16 - 18 x 1.0	.29	2.67	.71	.43	.34	1.84	1.27	.30
1	1065004	400	3.5	5/16 - 18 x 1.25	.54	2.67	.71	.43	.34	1.84	1.27	.30
1	1065008	500	6	3/8 - 16 x 1.25	.54	2.67	.71	.43	.34	1.84	1.27	.30
2	1065016	1250	14	1/2 - 13 x 2.0	.78	4.78	1.45	.88	.69	3.52	2.31	2.6
2	1065020	1250	14	1/2 - 13 x 2.25	1.03	4.78	1.45	.88	.69	3.52	2.31	2.6
2	1065024	1250	14	1/2 - 13 x 2.5	1.28	4.78	1.45	.88	.69	3.52	2.31	2.6
2	1065028	2000	30	5/8 - 11 x 2.0	.78	4.78	1.45	.88	.69	3.52	2.18	2.6
2	1065032	2000	30	5/8 - 11 x 2.25	1.03	4.78	1.45	.88	.69	3.52	2.18	2.6
2	1065036	2000	30	5/8 - 11 x 2.5	1.28	4.78	1.45	.88	.69	3.52	2.18	2.6
2	1065040	2500	50	3/4 - 10 x 2.25	1.03	4.78	1.45	.88	.69	3.52	2.06	3.0
2	1065044	2500	50	3/4 - 10 x 2.75	1.53	4.78	1.45	.88	.69	3.52	2.06	3.0
3	1065048	3500	50	3/4 - 10 x 2.75	1.04	6.52	2.20	1.40	.94	5.14	3.06	7.0
3	1065052	3500	50	3/4 - 10 x 3.25	1.54	6.52	2.20	1.40	.94	5.14	3.06	7.0
3	1065056	4000	80	7/8 - 9 x 2.75	1.04	6.52	2.20	1.40	.94	5.14	2.93	7.0
3	1065060	4000	80	7/8 - 9 x 3.0	1.29	6.52	2.20	1.40	.94	5.14	2.93	7.0
3	1065068	5000	115	1 - 8 x 3.25	1.54	6.52	2.20	1.40	.94	5.14	2.81	7.5
3	1065072	5000	115	1 - 8 x 4.0	2.29	6.52	2.20	1.40	.94	5.14	2.81	7.5
4	1065080	7500	235	1-1/4 - 7 x 4.0	1.89	8.73	3.19	1.75	1.25	6.50	4.12	14.0
5	1065084	12000	400	1-1/2 - 6 x 5.5	2.70	12.47	4.87	2.25	1.75	8.55	6.41	34.0
5	1065088	15000	550	2 - 4.5 x 5.75	2.96	12.47	4.87	2.25	1.75	8.55	5.91	36.0
6	1065092	25000	1050	2-1/2 - 4 x 8.0	4.00	16.87	6.52	3.00	2.25	11.67	8.03	88.0
6	1065096	25000	1050	2-1/2 - 8 x 8.0	4.00	16.87	6.52	3.00	2.25	11.67	8.03	88.0
7	1065100	37500	2150	3 - 4 x 10.25	5.00	19.50	8.10	3.75	2.75	14.15	8.48	166.0
8	1065104	50000	2550	3-1/2 - 4 x 13	7.00	22.09	8.60	4.00	3.25	15.90	9.28	265.0
8	1065263	22300	3459	1 - 8 x 3.0	177	561	216	102	83	404	235	118.0

\*Ultimate Load is 5 times the Working Load Limit.

‡ Bolt specification is 316 Stainless Steel socket head cap screw to ASTM F 837M Group 1 (316).



# Stainless Steel Swivel Hoist Rings



SS-125M

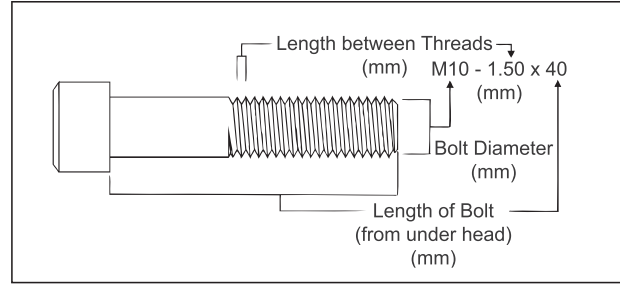
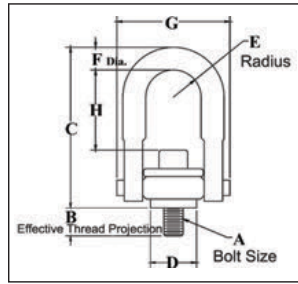

- All components are 316 stainless steel, except bolt retainers, which are made from 15-7 PH (UNS 15700) magnetic stainless steel.
- Available in capacities from 200 kg to 22.300 kg.
- Rated at 100 percent at 90 degree angle.
- Each product has a Product Identification Code (PIC) for material traceability, along with the Working Load Limit and the name Crosby or "CG" stamped into it.
- Individually proof tested to 2 times the Working Load Limit with certification.
- Fatigue Rated to 20,000 cycles at 1-1/2 times the Working Load Limit.
- Washer is color coded for easy identification (Silver - Metric thread).
- Bolt specification is 316 Stainless Steel socket head cap screw to ASTM F 837M (316).
- All threads listed are Metric (ASME/ANSI B18.3.1M).
- **BOLT SIZE IDENTIFICATION:** The size of the bolt will be stated as in the drawing above. Illustration shows meaning of each dimension given.
- **NOTE:** For Special Applications, see page 457.
- Frame 2 and larger are **RFID EQUIPPED**.

**Fatigue Rated**



**Load Rated**

**SEE APPLICATION AND WARNING INFORMATION**  
 On Pages 210 -211  
 Para Español: [www.thecrosbygroup.com](http://www.thecrosbygroup.com)

## SS-125M Metric Threads

Frame Size No.	SS-125M Stock No.	Working Load Limit (kg)*	Torque (Nm)	Dimensions (mm)								Weight Each (kg)
				Bolt Size A ‡	Effective Thread Projection Length B	C	D	Radius E	Diameter F	G	H	
1	1065203	200	4	M8 x 1.25	13	68	18	11	8.5	47	32	.17
1	1065207	250	8	M10 x 1.50	18	68	18	11	8.5	47	30	.17
2	1065211	525	18	M12 x 1.75	19	121	37	22	17.5	89	60	1.1
2	1065215	950	40	M16 x 2.00	29	121	37	22	17.5	89	56	1.1
2	1065219	1075	68	M20 x 2.50	34	121	37	22	17.5	89	52	1.2
3	1065223	1500	68	M20 x 2.50	32	166	56	36	25	131	78	3.0
3	1065227	2100	108	M24 x 3.00	37	166	56	36	25	131	74	3.1
3	1065231	2100	108	M30 x 3.50	58	206	56	36	25	131	108	3.1
4	1065235	3500	318	M30 x 3.50	42	222	81	45	31	165	106	6.3
4	1065239	3500	318	M30 x 3.50	62	222	81	45	31	165	106	6.4
5	1065243	5500	542	M36 x 4.00	64	317	124	57	43	217	166	15.5
5	1065247	6250	542	M42 x 4.50	82	317	124	57	43	217	160	16.0
5	1065251	6750	746	M48 x 5.00	82	317	124	57	43	217	154	16.8
6	1065255	11150	1423	M64 x 6.00	101	428	165	76	56	296	204	39.0
7	1065259	15750	2915	M72 x 6.00	132	495	206	95	69	359	220	74.0
8	1065263	22300	3459	M90 x 6.00	177	561	216	102	83	404	235	118.0

\*Ultimate Load is 5 times the Working Load Limit.

‡ Bolt specification is 316 Stainless Steel socket head cap screw to ASTM F 837 Group 1 (316).

## Trench Cover Hoist Rings



HR-500

- Designed to simplify the lifting and placement of steel plates used to cover trenches in streets.
- Provides a standard fitting to be used in place of products not designed for trench cover applications.
- Capacities of 2.27, 4.54 & 6.82t for plate thicknesses of 19mm to 38mm.
- Detailed welding instructions included with every hoist ring.
- Forged bail provides the following:
  - Easily readable raised lettering showing the name Crosby or "CG" and PIC code for material traceability.
  - More durability provides the increased "Toughness" desired in potentially abusive field conditions.
- 180 degree pivot and 360 degree rotation at full capacity.
- Design Factor of 5 to 1.
- Individually Proof Tested to 2-1/2 times Working Load Limit.
- All sizes are **RFID EQUIPPED**.

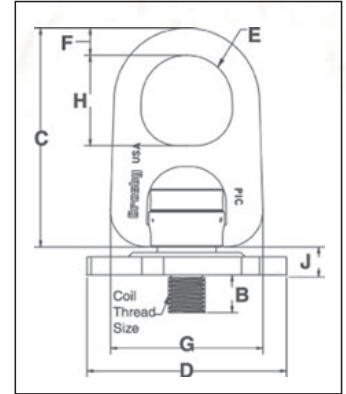

### HR-500 Trench Cover Hoist Rings Coil Threads

HR-500 Stock No.	Working Load Limit (t)*	Weight Each (kg)	Dimensions (mm)								
			Coil Thread Size A	Effective Thread Projection Length B	C	D	Radius E	F	G	H	J
1017907	2.27	2.5	1" - 3.5	25.4	150	140	31.8	19.1	107	63.5	19.6
1017916	4.54	7.1	1-1/4" - 3.5	25.4	210	178	41.4	25.4	159	82.5	20.6
1017925	6.82	13.5	1-1/2" - 3.5	38.1	270	232	51.0	31.8	199	102	20.3

\*Ultimate Load is 5 times the Working Load Limit.



HRN-500

### HRN-500 Trench Cover Nuts

HRN-500 Stock No.	Working Load Limit (t)	Weight Each (kg)	Coil Thread Size	Dimensions (mm)		
				Nut Diam. K	Trench Cover Hole Diam. L	Nut Thickness M
1063405	2.27	.45	1" - 3.5	76.2	79.2	19.1
1063414	2.27	.64	1" - 3.5	76.2	79.2	22.4
1063423	2.27	.73	1" - 3.5	76.2	79.2	25.4
1063432	4.54	.50	1-1/4" - 3.5	76.2	79.2	19.1
1063441	4.54	.59	1-1/4" - 3.5	76.2	79.2	22.4
1063450	4.54	.68	1-1/4" - 3.5	76.2	79.2	25.4
1063454	4.54	.86	1-1/4" - 3.5	76.2	79.2	31.8
1063458	4.54	1.04	1-1/4" - 3.5	76.2	79.2	38.1
1063469	6.82	.91	1-1/2" - 3.5	88.9	91.9	25.4
1063478	6.82	1.18	1-1/2" - 3.5	88.9	91.9	31.8
1063487	6.82	1.41	1-1/2" - 3.5	88.9	91.9	38.1

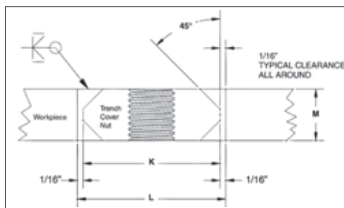

## Trench Cover Lifting Ring Tools and Accessories



### HR-500HG Hole Gauge

Aids in determining when studs and plate nuts need replacing.

Coil Thread Size (in.)	HR-500HG Stock No.	Weight Each (kg)
1.00 - 3.5	1064666	.27
1.25 - 3.5	1064675	.36
1.50 - 3.5	1064684	.45



### HR-500TC Thread Clean-Up Tool

Cleans dirt and other material as from nut threads.

Coil Thread Size (in.)	HR-500TC Stock No.	Weight Each (kg)
1.00 - 3.5	1064639	.27
1.25 - 3.5	1064648	.36
1.50 - 3.5	1064657	.45



### HR-500WF Weld Fixture

Holds nut securely in place to ease in initial tack welding.

Coil Thread Size (in.)	HR-500WF Stock No.	Weight Each (kg)
1.00 - 3.5	1064602	.27
1.25 - 3.5	1064611	.36
1.50 - 3.5	1064620	.45

# Pivot Hoist Rings



**HR-100 UNC**  
**HR-100M METRIC**

- Forged bail provides the following:
  - Easily readable raised lettering showing the name Crosby or "CG" and PIC code for material traceability.
  - More durability provides the increased "Toughness" desired in potentially abusive field conditions.
  - Larger opening than standard Hoist Ring bails.
- 180 degree pivot action at full capacity.
- Bolts included as part of assembly.
- Design Factor of 5 to 1.
- Individually Proof Tested to 2-1/2 times Working Load Limit.
- UNC Bolt specification is a Grade 8 Alloy socket head cap screw to ASTM A 574.
- Metric Bolt specification is a Grade 12.9 Alloy socket head cap screw to DIN 912.
- Frame 2 and larger are **RFID EQUIPPED**.

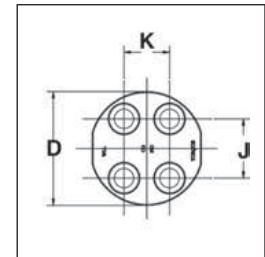
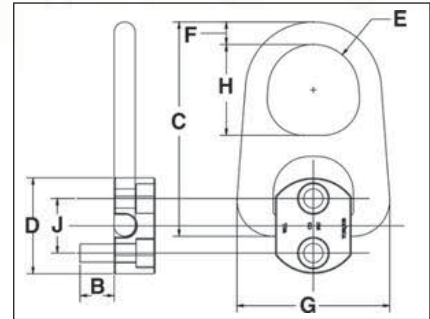

**Load Rated**

**SEE APPLICATION AND WARNING INFORMATION**  
On Page 202-203  
Para Español: [www.thecrosbygroup.com](http://www.thecrosbygroup.com)

## HR-100 Pivot Hoist Rings Coil Threads

Frame Size No.	HR-100 Stock No.	Working Load Limit (kg)*	Torque (Nm)	No. of Bolts	Weight Each (kg)	Bolt Size A (in.)	Dimensions (mm)									
							Effective Thread Projection Length B	C	Diameter D	Radius E	F	G	H	J	K	
1	1067408	907	10	2	.30	5/16-18 x 1.25	20.8	87.1	50.8	15.7	11.2	57.7	35.1	25.4	-	
2	1067417	1134	16	2	1.40	3/8-16 x 1.25	16.5	153	57.2	31.8	19.1	107	63.5	28.6	-	
2	1067426	2268	38	2	1.50	1/2-13 x 2.00	35.6	153	66.8	31.8	19.1	107	63.5	38.1	-	
3	1067435	5443	38	4	4.80	1/2-13 x 2.75	41.9	210	79.5	41.4	25.4	159	82.6	41.3	31.8	
4	1067444	9072	81	4	10.0	5/8-11 x 3.25	41.9	270	114	50.8	31.8	199	102	52.4	31.8	

\*Ultimate Load is 5 times the Working Load Limit.

## HR-100M Pivot Hoist Rings Metric Threads

Frame Size No.	HR-100M Stock No.	Working Load Limit (kg)*	Torque (Nm)	No. of Bolts	Weight Each (kg)	Bolt Size A	Dimensions (mm)									
							Effective Thread Projection Length B	C	Diameter D	Radius E	F	G	H	J	K	
1	1067905	900	10	2	.3	M8-1.25 x 30	19.1	87.1	51.0	15.8	11.2	57.7	35.1	25.4	-	
2	1067914	1150	16	2	1.4	M10-1.50 x 30	14.8	153	57.2	31.8	19.1	107	63.5	28.6	-	
2	1067923	2150	38	2	1.5	M12-1.75 x 50	34.8	153	66.8	31.8	19.1	107	63.5	38.1	-	
3	1067932	5100	38	4	4.8	M12-1.75 x 70	42.1	210	79.5	41.4	25.4	159	82.6	41.3	31.8	
4	1067941	9000	81	4	10.0	M16-2.00 x 80	39.4	270	114	51.0	31.8	199	102	52.4	31.8	

\*Ultimate Load is 5 times the Working Load Limit.

**RIGGING ACCESSORIES**



## HR-1200 Side Pull Hoist Rings



HR-1200

- Wide range of capacities available:
  - 650 lbs. to 29,000 lbs.
  - Metric sizes from 300 kg. to 13,000 kg.
- Body components are Alloy Steel - Quenched and Tempered.
- Rated at 100% of Working Load Limit for angles up to 90 degrees.
- Each product is stamped with a Product Identification Code (PIC) for material traceability, along with a Working Load Limit, and the name Crosby or "CG".
- Hoist Ring body is furnished with Yellow Chromate finish for improved corrosion resistance.
- Utilize standard Crosby Red Pin® Shackles to connect to wire rope or synthetic slings. (sold separately)
- Multiple bolt lengths available to meet specific application requirements.
- Individually Proof Tested to 2-1/2 times Working Load Limit.
- All sizes are **RFID EQUIPPED**.

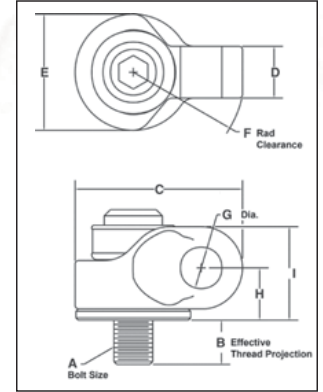

### HR-1200 UNC Side Pull Hoist Rings

Weight Each (kg.)	Working Load Limit (lbs.)*	HR-1200 Stock No.	Hoist Ring Bolt Torque (Ft. Lbs.)	A Bolt Size (mm)	B Eff. Thread Proj. (mm)	Dimensions (mm)								Recommended Shackles			
						C	D	E	F	Dia. G	H	I	Red Pin® Shackles 209,210,213, 215,2130,2150		Red Pin Web Shackles S-281		
													Nominal Size (in.)	WLL (t)	Web Size (mm)	WLL (t)	
.16	650	1067700	7	5/16-18x1.50	15.0	49.0	18.3	25.4	39.6	20.3	21.6	36.3	1/2, 5/8	2, 3-1/4	50	2.95	
.16	800	1067704	12	3/8-16x1.50	15.0	49.0	18.3	25.4	39.6	20.3	21.6	36.3	1/2, 5/8	2, 3-1/4	50	2.95	
.64	2000	1067708	28	1/2-13x2.00	18.0	75.4	24.6	50.8	54.1	23.6	27.2	45.5	5/8, 3/4	3-1/4, 4-3/4	50, 35	2.95, 4.08	
.64	2000	1067712	28	1/2-13x2.50	30.7	75.4	24.6	50.8	54.1	23.6	27.2	45.5	5/8, 3/4	3-1/4, 4-3/4	50, 35	2.95, 4.08	
.68	3000	1067716	60	5/8-11x2.00	18.0	75.4	24.6	50.8	54.1	23.6	27.2	45.5	5/8, 3/4	3-1/4, 4-3/4	50, 35	2.95, 4.08	
.68	3000	1067720	60	5/8-11x2.75	37.1	75.4	24.6	50.8	54.1	23.6	27.2	45.5	5/8, 3/4	3-1/4, 4-3/4	50, 35	2.95, 4.08	
2.04	5000	1067724	100	3/4-10x2.75	22.9	110	34.0	76.2	76.2	27.2	34.3	61.5	7/8	6-1/2	50	5.67	
2.09	5000	1067728	100	3/4-10x3.50	41.9	110	34.0	76.2	76.2	27.2	34.3	61.5	7/8	6-1/2	50	5.67	
2.09	6500	1067732	160	7/8-9x2.75	22.9	110	34.0	76.2	76.2	27.2	34.3	61.5	7/8	6-1/2	50	5.67	
2.18	6500	1067736	160	7/8-9x3.50	41.9	110	34.0	76.2	76.2	27.2	34.3	61.5	7/8	6-1/2	50	5.67	
2.18	8000	1067740	230	1-8x3.00	29.2	110	34.0	76.2	76.2	27.2	34.3	61.5	7/8	6-1/2	50	5.67	
2.27	8000	1067744	230	1-8x4.00	54.6	110	34.0	76.2	76.2	27.2	34.3	61.5	7/8	6-1/2	50	5.67	
4.63	14000	1067748	470	1-1/4-7x4.5	56.4	142	39.9	95.3	99.3	37.3	48.8	86.9	1, 1-1/8, 1-1/4	8-1/2, 9-1/2, 12	75	7.70	
10.7	17200	1067756	800	1-1/2-6x6.5	75.7	186	52.3	121	132	53.6	61.2	109	1-3/8, 1-1/2, 1-3/4	13-1/2, 17, 25	-	-	
11.5	29000	1067764	1100	2-4.5x6.5	75.7	186	52.3	121	132	53.6	61.2	109	1-3/8, 1-1/2, 1-3/4	13-1/2, 17, 25	-	-	

\*Ultimate Load is 5 times the Working Load Limit.

### HR-1200M Metric Side Pull Hoist Rings

Weight Each (kg)	Working Load Limit (kg)*	HR-1200M Stock No.	Hoist Ring Bolt Torque (Nm)	(A) Bolt Size (mm)	(B) Eff. Thread Proj. (mm)	Dimensions (mm)								Recommended Shackles			
						C	D	E	F	G	H	I	Red Pin® Shackles 209,210,213, 215,2130,2150		Red Pin Web Shackles S-281		
													Nominal Size (in.)	WLL (t)	Web Size (mm)	WLL (t)	
.18	300	1067803	10	M8x1.25x40	16.9	49.0	18.3	25.4	39.6	20.3	21.6	36.3	1/2, 5/8	2, 3-1/4	50	2.95	
.18	400	1067807	16	M10x1.50x40	16.9	49.0	18.3	25.4	39.6	20.3	21.6	36.3	1/2, 5/8	2, 3-1/4	50	2.95	
.63	1000	1067811	38	M12x1.75x50	17.2	75.4	24.6	50.8	54.1	23.6	27.2	45.5	5/8, 3/4	3-1/4, 4-3/4	50, 35	2.95, 4.08	
.68	1400	1067815	81	M16x2.0x60	27.2	75.4	24.6	50.8	54.1	23.6	27.2	45.5	5/8, 3/4	3-1/4, 4-3/4	50, 35	2.95, 4.08	
2.0	2250	1067823	136	M20x2.5x75	28.1	110	34.0	76.2	76.2	27.2	34.4	61.5	7/8	6-1/2	50	5.67	
2.2	3500	1067827	312	M24x3.0x80	33.1	110	34.0	76.2	76.2	27.2	34.4	61.5	7/8	6-1/2	50	5.67	
4.5	6250	1067831	637	M30x3.5x120	65.1	142	39.9	95.3	99.3	37.3	48.8	86.9	1, 1-1/8, 1-1/4	8-1/2, 9-1/2, 12	75	7.70	
10.4	7750	1067835	1005	M36x4.0x150	60.6	186	52.3	121	132	53.6	61.2	109	1-3/8, 1-1/2, 1-3/4	13-1/2, 17, 25	-	-	
10.7	10000	1067839	1005	M42x4.5x160	70.6	186	52.3	121	132	53.6	61.2	109	1-3/8, 1-1/2, 1-3/4	13-1/2, 17, 25	-	-	
11.0	13000	1067843	1350	M48x5.0x160	70.6	186	52.3	121	132	53.6	61.2	109	1-3/8, 1-1/2, 1-3/4	13-1/2, 17, 25	-	-	

\*Ultimate Load is 5 times the Working Load Limit.

# Hoist Ring to Chain or Webbing



**HR-125C**  
Hoist Ring to Chain

- Available in capacities from 2 to 8.2 tonnes.
- Fits Grade 8 Chain size 7, 8, 10, 13 and 16mm.
- Forged Alloy Steel.
- Design factor of 4 to 1.
- Individually Proof Tested to 2-1/2 times Working Load Limit.
- "Yellow Chromate" finish for increased corrosion protection.
- Full 360 degrees swivel and 180 degrees pivot action.
- Bolt specification is a Grade 8 Alloy socket head cap screw to ASTM A574. All threads are UNC.
- All sizes are **RFID EQUIPPED**.

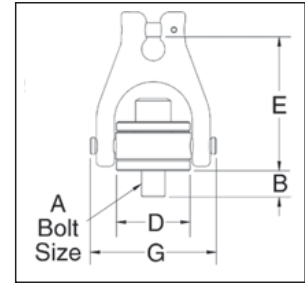

## HR-125C Hoist Ring to Chain

HR-125C Stock No.	Working Load Limit (t)*	Torque (Nm)	Effective Thread Projection Length (mm)	Spectrum 8 Chain Size (in. - mm)	Dimensions (mm)					Weight Each (kg)
					UNC Thread A ‡	B	D	E	G	
1067492	2	81	18.0	1/4-5/16 7-8	5/8-11 x 2.00	17.8	49.8	90.0	85.0	.95
1067494	2	81	37.1	1/4-5/16 7-8	5/8-11 x 2.75	30.5	49.8	90.0	85.0	.95
1067500	3.2	136	22.9	3/8 10	3/4-10 x 2.75	22.6	75.0	121	124	2.45
1067502	3.2	136	41.9	3/8 10	3/4-10 x 3.50	41.7	75.0	121	124	2.45
1067509	5.4	312	29.2	1/2 13	1-8 x 3.00	29.0	75.0	122	124	2.90
1067511	5.4	312	54.6	1/2 13	1-8 x 4.00	54.5	75.0	122	124	3.04
1067518	8.2	637	56.4	5/8 16	1-1/4-7 x 4.50	56.0	94.0	166	157	5.81

\*Ultimate load is 4 times the Working Load Limit. Individually tested to 2-1/2 the Working Load Limit. ‡ Long Bolts are designed to be used with soft metal (i.e., aluminum) workpiece. While the long bolts may also be used with ferrous metal (i.e., steel & iron) workpiece, short bolts are designed for ferrous workpieces only.



**HR-125W**  
Hoist Ring to Web

- Available in capacities from 2.8 to 5.6t.
- Fits webbing sizes 50 to 100mm.
- Forged Alloy Steel
- Durable plastic cover protects the sling at the eye as well as keeps the sling positioned correctly on the spool.
- Bolt specification is a Grade 8 Alloy socket head cap screw to ASTM A574. All threads are UNC.
- Design Factor of 5 to 1.
- Individually Proof Tested to 2-1/2 times the Working Load Limit.
- Designed for use with Type III (Eye & Eye), class 7, 2 ply webbing & synthetic round slings. Also accommodates single ply endless slings.
- All sizes are **RFID EQUIPPED**.

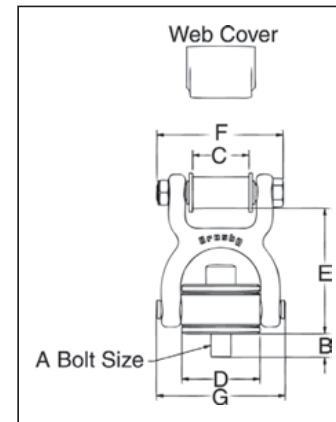

## HR-125W Hoist Ring to Web

HR-125W Stock No.	Round Sling Size (No.)	Web Width (mm)	Eye Width (mm)	Working Load Limit (t)*	Torque (Nm)	Eff. Thread Proj. Length (mm)	Spool bolt & nut Torque in Ft.-Lbs.	Dimensions (mm)							Weight Each (kg)
								UNC Thread A ‡	B	C	D	E	F	G	
1067610	1 & 2	50	50	2.8	136	22.9	90	3/4-10x2.75	22.6	54.0	75.0	121	121	124	2.81
1067615	1 & 2	50	50	2.8	136	41.9	90	3/4-10x3.50	41.7	54.0	75.0	121	121	124	2.86
1067629	3	75	35	4.0	312	29.2	110	1-8x3.00	29.0	41.4	75.0	121	115	124	3.22
1067634	3	75	35	4.0	312	54.6	110	1-8x4.00	54.5	41.4	75.0	121	115	124	3.31
1067638	4	100	50	5.6	637	56.4	130	1-1/4-7x4.5	56.0	54.0	94.0	158	109	157	6.21

\*Ultimate load is 5 times the Working Load Limit. Individually tested to 2-1/2 times the Working Load Limit. ‡ Long Bolts are designed to be used with soft metal (i.e., aluminum) workpiece. While the long bolts may also be used with ferrous metal (i.e., steel & iron) workpiece, short bolts are designed for ferrous workpieces only.



# Crosby SL150M Slide-Loc™

www.thecrosbygroup.com

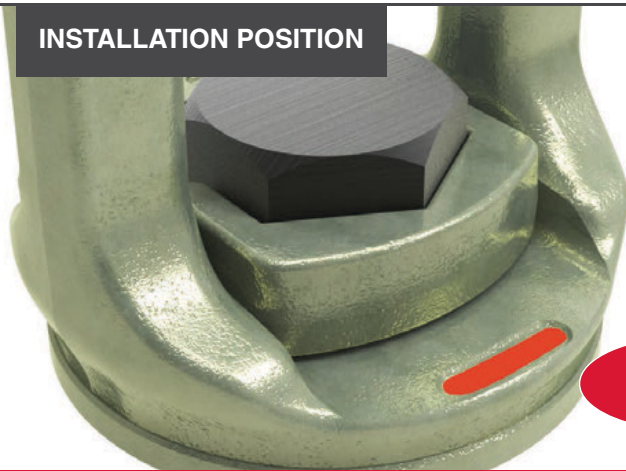

INSTALLATION POSITION

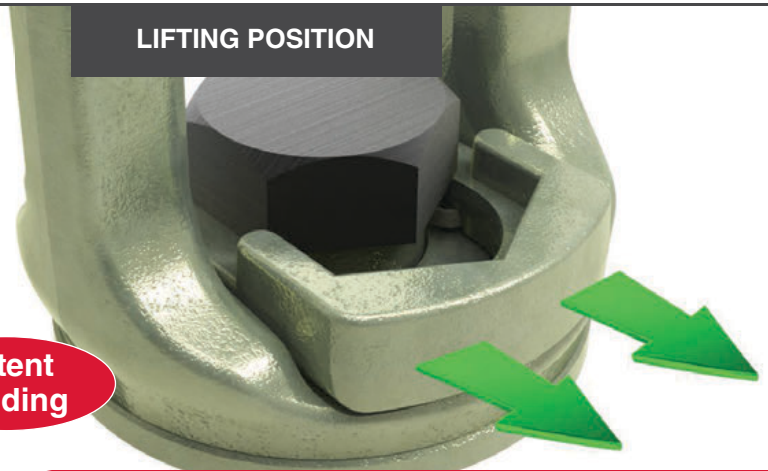

LIFTING POSITION

Patent Pending

The visible red QUIC-CHECK® mark indicates that the Crosby Slide-Loc™ is ready for installation but not for lifting.

QUIC-CHECK®



When the red QUIC-CHECK® mark is under the slide, the Crosby Slide-Loc™ is ready for lifting.

## CROSBY'S INNOVATIVE ALTERNATIVE TO STANDARD EYE BOLTS

The new Crosby SL150M Slide-Loc™ provides features not found on standard lifting eye bolts. At the center of the new design is the **patent pending locking mechanism** that slides to lock the bolt for faster installation, then slides back to make ready for lifting — *without the need for tools*.

- When compared to respective size eye bolts, the Crosby SL150M Slide-Loc™:
  - Has a larger eye opening for easy access.
  - Utilizes a bail that swivels 360° to keep load aligned with the sling leg, and maintains full WLL at any angle.
- Fatigue Rated® to 20,000 cycles at 1-1/2 times the WLL.
- The patent pending locking mechanism provides quicker installation, without the need for tools.
- QUIC-CHECK® mark indicates if the Crosby SL150M Slide-Loc™ is ready for the lift.
- Forged alloy steel and Quenched and Tempered bail provides toughness in potentially abusive field conditions.
- Meets the Machinery Directive 2006/42/EC guidelines and is marked with CE accordingly.

Swivels 360°



View Video

Fatigue Rated®



Load Rated®

QUIC-CHECK®





# Lifting Points



**NEW**

**SL-150**  
Slide-Loc  
Lifting Point

- Available in capacities from .5 to 3.2 metric tons
- Bail is Forged Alloy Steel – Quenched and Tempered
- Bail swivels 360° degree
- Rated at 100% for 90 degree angle.
- Fatigue rated to 20,000 cycles at 1-1/2 times the Working Load Limit.
- Meets the Machinery Directive 2006/42/EC guidelines and is marked with CE accordingly.
- Meets or exceeds all requirements of ASME B30.26 including identification, ductility, design factor, proof load and temperature requirements. Importantly, these bolts meet other critical performance requirements including fatigue life, impact properties and material traceability, not addressed by ASME B30.26.
- Replaceable bolts available, including longer bolts.
- Bolt specification for metric bolt is Grade 10.9 alloy cap screw to ISO 898-1.
- Unique locking mechanism makes the lifting point well suited for quick attachment to load surface. No need for tools.
- Features **QUIC-CHECK®** markings on bail to assist in knowing when device is ready for lifting.

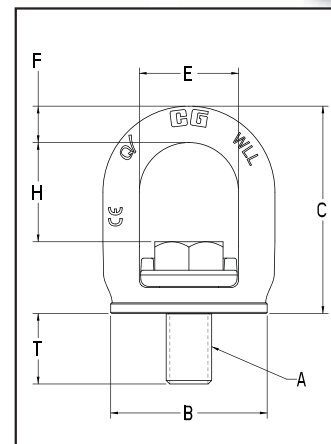

**Load Rated**

**Fatigue Rated**

**QUIC-CHECK®**



**SEE APPLICATION AND WARNING INFORMATION**  
On Page 210 -211  
Para Español: [www.thecrosbygroup.com](http://www.thecrosbygroup.com)

## SL-150 UNC SLIDE-LOC™ LIFT POINT

Weight Each (lbs.)	SL-150M Stock No.	Working Load Limit (t)*	Dimensions (in.)						Effective Thread Projection Length T
			Bolt Size A	B	C	F	E	H	
0.30	1068507	.5	3/8 - 16 x 1	1.40	2.09	0.33	1.10	1.10	14.7
0.53	1068516	.75	1/2 - 13 x 1 - 1/4	1.67	2.48	0.41	1.30	1.30	18.1
1.10	1068525	1.5	5/8 - 11 x 1 - 5/8	2.17	2.98	0.52	1.46	1.46	24.5
2.05	1068534	2.3	3/4 - 10 x 2	2.71	3.59	0.63	1.72	1.72	1.25
2.16	1068543	2.3	7/8 - 9 x 2 - 1/1	2.71	3.56	0.63	1.72	43.6	1.28
3.73	1068552	3.2	1 - 8 x 3	3.25	4.33	0.72	2.08	52.8	1.59

\*Ultimate load is 4 times the Working Load Limit.

## SL-150 M Metric SLIDE-LOC™ LIFT POINT

Weight Each (kg)	SL-150M Stock No.	Working Load Limit (t)*	Dimensions (mm.)						Effective Thread Projection Length T
			Bolt Size A	B	C	F	E	H	
.14	1068515	.5	M10X1.5 X 25	35,5	53,1	8,5	28,0	28,0	14,7
.23	1068524	.75	M12x1.75x30	42,5	62,9	10,5	33,0	33,0	18,1
.50	1068533	1.5	M16x2x40	55,0	75,7	13,2	37,0	37,0	24,5
.94	1068542	2.3	M20x2.5x50	68,8	91,1	16,0	43,6	43,6	31,0
1.60	1068551	3.2	M24x3x60	82,5	110,0	18,2	52,8	52,8	37,0

\*Ultimate load is 4 times the Working Load Limit.



**S-265**  
Weld-On Pivot Link

- Forged Steel — Quenched and Tempered.
- Excellent welding qualities.
- Widely used on farm machinery, trucks, steel hulled marine vessels and material handling equipment.
- Reference American Welding Society specifications for proper welding procedures.



**SEE APPLICATION AND WARNING INFORMATION**  
On Pages 218 -209  
Para Español: [www.thecrosbygroup.com](http://www.thecrosbygroup.com)

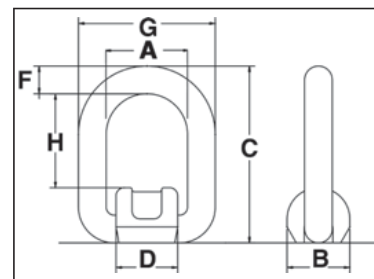

## S-265 Weld-On Pivot Link

Working Load Limit (t)		S-265 Stock No	Weight Each (kg)	Dimensions (mm)							Minimum Fillet Weld Size (mm)
Design Factor 5:1	Design Factor 4:1			A	B	C	D	F	G	H	
1	1.2	1290740	.40	40	36	83	35	13	66	42	3
2.5	3.2	1290768	.60	45	44	99	42	18	81	48	3
4.2	5.3	1290786	1.20	55	50	123	49	22	99	57	6
6.4	8	1290802	2.40	70	64	144	64	26	122	67	6
12	15	1290820	5.90	97	90	193	86	34	165	94	8

**RIGGING ACCESSORIES**

**HG-223**

**HOOK & HOOK**

Meets the performance requirements of Federal Specifications FF-T-791b, Type 1, Form 1, Class 5, and ASTM F-1145, except for those provisions required of the contractor.



**HG-225**

**HOOK & EYE**

Meets the performance requirements of Federal Specifications FF-T-791b, Type 1, Form 1, Class 6, and ASTM F-1145, except for those provisions required of the contractor.



**HG-226**

**EYE & EYE**

Meets the performance requirements of Federal Specifications FF-T-791b, Type 1, Form 1, Class 4, and ASTM F-1145, except for those provisions required of the contractor.



**HG-227**

**JAW & EYE**

Meets the performance requirements of Federal Specifications FF-T-791b, Type 1, Form 1, Class 8, and ASTM F-1145, except for those provisions required of the contractor.



**HG-228**

**JAW & JAW**

Meets the performance requirements of Federal Specifications FF-T-791b, Type 1, Form 1, Class 7, and ASTM F-1145, except for those provisions required of the contractor.

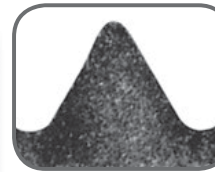

**Modified Thread:**

Note stress relieving radii in this unretouched photo enlargement of the supabuckle.



**Standard Thread:**

Note stress building sharp "V" in this unretouched photo enlargement.



**Turnbuckle Information**

- Turnbuckle assembly combinations include: Eye and Eye, Hook and Hook, Hook and Eye, Jaw and Jaw & Jaw and Eye.
- End fittings are Quenched and Tempered or Normalized, bodies heat treated by normalizing.
- Crosby's Quenched and Tempered end fittings and normalized bodies have enhanced impact properties for greater toughness at all temperatures.
- Hot Dip galvanized.
- Hooks are forged with a greater cross sectional area that results in a stronger hook with better fatigue properties.
- Modified UNJ thread on end fittings for improved fatigue properties. Body has UNC threads.
- Turnbuckle eyes are forged elongated, by design, to maximize easy attachment in system and minimize stress in the eye. For turnbuckle sizes 6.35mm through 63.5mm, a shackle one size smaller can be reeved through eye.
- Forged jaw ends are fitted with bolts and nuts on size 6.35mm- 15.9mm, and pins and cotter on sizes 19.1mm - 70.0mm.

**TURNBUCKLES RECOMMENDED FOR STRAIGHT OR IN-LINE PULL ONLY.**

- Lock Nuts available for all sizes.
- Typical hardness levels, tensile strengths and ductility properties are available for all sizes.
- Turnbuckles can be furnished proof tested or magnaflux inspected with certificates if requested at time of order.
- Meets or exceeds all the requirements of ASME B30.26 including identification, ductility, design factor, proof load and temperature requirements. Importantly, these turnbuckles meet other critical performance requirements, including fatigue life, impact properties and material traceability, not addressed by ASME B30.26.

# Hooks & Hook Turnbuckles



**HG -223**  
Hook & Hook

- End fittings are Quenched and Tempered or Normalized, bodies heat treated by normalizing.
- Hot Dip galvanized steel.
- Hooks are forged with a greater cross sectional area that results in a stronger hook with better fatigue properties.
- **TURNBUCKLES RECOMMENDED FOR STRAIGHT OR IN-LINE PULL ONLY.**
- Modified UNJ thread on end fittings for improved fatigue properties.
- Body has UNC threads.
- Lock Nuts available for all sizes (see page 198).
- Comprehensive end fitting data provided on page 194.
- Fatigue Rated.
- Meets or exceeds all requirements of ASME B30.26 including identification, ductility, design factor, proof load and temperature requirements. Importantly, these turnbuckles meet other critical performance requirements including fatigue life, impact properties and material traceability, not addressed by ASME B30.26.

Meets the performance requirements of Federal Specifications FF-T-791b, Type 1 Form 1 - CLASS 5, and ASTM F-1145, except for those provisions required of the contractor. For additional information, see page 476.

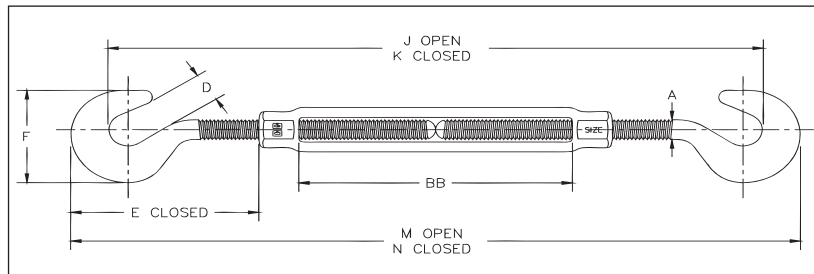

## HG-223 Hook & Hook

Thread Diameter & Take Up (mm)	HG-223 Stock No.	Working Load Limit (t)*	Weight Each (kg)	Dimensions (mm)								
				A	D	E Closed	F	J Open	K Closed	M Open	N Closed	BB
† 6.35 x 102	1030011	.18	.15	6.35	11.2	42.3	32.3	249	187	310	208	103
† 7.94 x 114	1030039	.32	.24	7.94	12.7	50.7	38.1	294	218	358	243	116
† 9.53 x 152	1030057	.45	.38	9.53	14.2	57.8	44.7	387	270	453	301	155
12.7 x 152	1030075	.68	.85	12.7	16.5	89.7	57.9	457	335	527	375	153
12.7 x 305	1030119	.68	1.26	12.7	16.5	89.2	57.9	769	495	839	535	314
15.9 x 305	1030137	1.02	1.46	15.9	22.9	108	71.4	495	368	572	419	153
15.9 x 305	1030173	1.02	2.08	15.9	22.9	107	71.4	809	529	885	580	315
19.1 x 152	1030191	1.36	1.91	19.1	24.9	129	84.6	538	406	620	467	156
19.1 x 305	1030235	1.36	3.14	19.1	24.9	128	84.6	853	568	935	630	320
19.1 x 457	1030253	1.36	3.92	19.1	24.9	129	84.6	1158	721	1240	782	471
22.2 x 305	1030271	1.81	4.47	22.2	28.7	148	96.0	886	597	972	667	309
25.4 x 305	1030333	2.27	6.70	25.4	31.8	167	108	929	637	1019	714	309

\*Proof Load is 2.5 times the Working Load Limit. Ultimate Load is 5 times the Working Load Limit. † Mechanical Galvanized





**HG -225**  
Hook & Eye

Meets the performance requirements of Federal Specifications FF-T-791b, Type 1 Form 1 - CLASS 4, and ASTM F-1145, except for those provisions required of the contractor. For additional information, see page 476.

- End fittings are Quenched and Tempered or Normalized, bodies heat treated by normalizing.
- Hot Dip galvanized steel.
- Turnbuckle eyes are forged elongated, by design, to maximize easy attachment in system and minimize stress in the eye. For turnbuckles sizes 6mm through 25mm, a shackle one size smaller can be reeved through eye.
- Turnbuckle hooks are forged with a greater cross sectional area that results in a stronger hook with better fatigue properties.
- **TURNBUCKLES RECOMMENDED FOR STRAIGHT OR IN-LINE PULL ONLY.**
- Modified UNJ thread on end fittings for improved fatigue properties.
- Body has UNC threads.
- Lock Nuts available for all sizes (see page 198).
- Comprehensive end fitting data provided on pages 195 & 196.
- Fatigue Rated.
- Meets or exceeds all requirements of ASME B30.26 including identification, ductility, design factor, proof load and temperature requirements. Importantly, these turnbuckles meet other critical performance requirements including fatigue life, impact properties and material traceability, not addressed by ASME B30.26

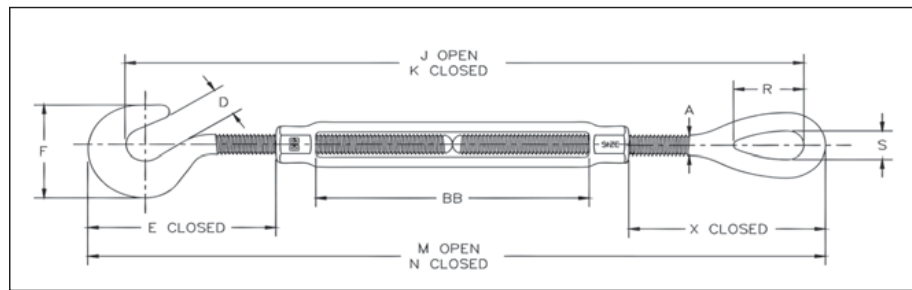

**HG-225 Hook & Eye**

Thread Diameter & Take Up (mm)	HG-225 Stock No.	Working Load Limit (t)*	Weight Each (kg)	Dimensions (mm)											
				A	D	E Closed	F	J Open	K Closed	M Open	N Closed	R	S	X Closed	BB
† 6.35 x 102	1030636	.18	.14	6.35	11.2	42.3	32.3	296	195	312	211	20.6	8.64	44.6	103
† 7.94 x 114	1030654	.32	.23	7.94	12.7	50.7	38.1	343	229	363	248	24.1	11.2	55.8	116
† 9.53 x 152	1030672	.45	.36	9.53	14.2	57.8	44.7	434	282	458	306	28.7	13.5	62.9	155
12.7 x 152	1030690	.68	.82	12.7	16.5	89.7	57.9	497	345	528	376	35.8	18.0	90.4	153
12.7 x 305	1030734	.68	1.22	12.7	16.5	89.2	57.9	809	504	840	535	35.8	18.0	89.9	314
15.9 x 152	1030752	1.02	1.35	15.9	22.9	108	71.4	536	384	574	422	45.7	22.4	110	153
15.9 x 305	1030798	1.02	1.97	15.9	22.9	107	71.4	850	545	888	583	45.7	22.4	110	315
19.1 x 152	1030814	1.36	1.91	19.1	24.9	129	84.6	574	422	621	469	53.1	25.4	130	156
19.1 x 305	1030850	1.36	2.96	19.1	24.9	128	84.6	889	584	936	631	53.1	25.4	129	320
19.1 x 457	1030878	1.36	3.74	19.1	24.9	129	84.6	1194	737	1241	784	53.1	25.4	130	471
22.2 x 305	1030896	1.81	4.24	22.2	28.7	148	96.0	917	612	971	666	60.5	31.8	147	309
25.4 x 305	1030958	2.27	6.29	25.4	31.8	167	108	956	652	1018	713	76.2	36.3	165	309

\*Proof Load is 2.5 times the Working Load Limit. Ultimate Load is 5 times the Working Load Limit. † Mechanical Galvanized

# Eye & Eye Turnbuckles



**HG -226**  
Eye & Eye

Meets the performance requirements of Federal Specifications FF-T-791b, Type 1 Form 1 - CLASS 4, and ASTM F-1145, except for those provisions required of the contractor. For additional information, see page 476.

- End fittings are Quenched and Tempered or Normalized, bodies heat treated by normalizing.
- Hot Dip galvanized steel.
- Turnbuckle eyes are forged elongated, by design, to maximize easy attachment in system and minimize stress in the eye. For turnbuckle sizes 6 mm through 64 mm, a shackle one size smaller can be reeved through eye.
- Modified UNJ thread on end fittings for improved fatigue properties. Body has UNC threads.
- **TURNBUCKLES RECOMMENDED FOR STRAIGHT OR IN-LINE PULL ONLY.**
- Lock Nuts available for all sizes (see page 198).
- Comprehensive end fitting data provided on page 195.
- Fatigue Rated.
- Meets or exceeds all requirements of ASME B30.26 including identification, ductility, design factor, proof load and temperature requirements. Importantly, these turnbuckles meet other critical performance requirements including fatigue life, impact properties and material traceability, not addressed by ASME B30.26.

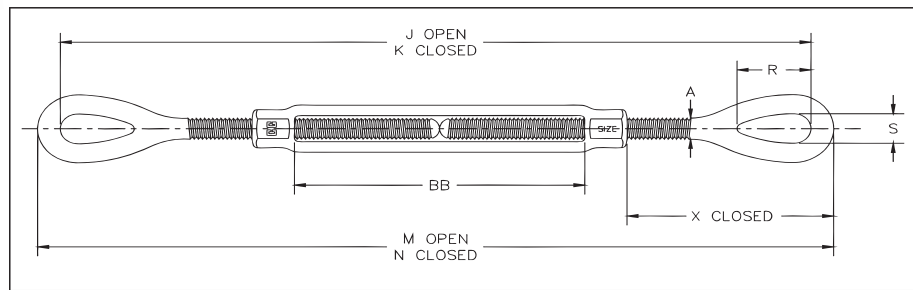

**QT** Fatigue Rated

## HG-226 Eye & Eye

Thread Diameter & Take Up (mm)	HG-226 Stock No.	Working Load Limit (t)*	Weight Each (kg)	Dimensions (mm)								
				A	J Open	K Closed	M Open	N Closed	R	S	X Closed	BB
† 6.35 x 102	1031252	.23	.13	6.35	303	202	314	213	20.6	8.64	44.6	103
† 7.94 x 114	1031270	.36	.22	7.94	354	239	368	253	24.1	11.2	55.8	116
† 9.53 x 152	1031298	.54	.34	9.53	446	294	463	311	28.7	13.5	62.9	155
12.7 x 152	1031314	1.00	.78	12.7	506	354	529	376	35.8	18.0	90.4	153
12.7 x 305	1031350	1.00	1.19	12.7	819	514	841	536	35.8	18.0	89.9	314
15.9 x 152	1031378	1.59	1.25	15.9	552	399	577	425	45.7	22.4	110	153
15.9 x 305	1031412	1.59	1.87	15.9	865	560	891	586	45.7	22.4	110	315
19.1 x 152	1031430	2.36	1.91	19.1	590	438	622	470	53.1	25.4	130	156
19.1 x 305	1031476	2.36	2.78	19.1	905	600	937	632	53.1	25.4	129	320
19.1 x 457	1031494	2.36	3.55	19.1	1210	753	1242	785	53.1	25.4	130	471
22.2 x 305	1031519	3.27	4.01	22.2	932	627	970	665	60.5	31.8	147	309
22.2 x 457	1031537	3.27	5.22	22.2	1249	792	1287	830	60.5	31.8	147	473
25.4 x 152	1031555	4.54	4.36	25.4	666	514	711	559	76.2	36.3	165	157
25.4 x 305	1031573	4.54	5.88	25.4	971	666	1016	711	76.2	36.3	165	309
25.4 x 457	1031591	4.54	7.40	25.4	1276	819	1321	864	76.2	36.3	165	462
25.4 x 610	1031617	4.54	9.14	25.4	1596	987	1641	1031	76.2	36.3	164	631
31.8 x 305	1031635	6.89	9.01	31.8	1070	766	1127	822	91.2	46.2	216	306
31.8 x 457	1031653	6.89	10.8	31.8	1375	918	1432	975	91.2	46.2	216	459
31.8 x 610	1031671	6.89	12.6	31.8	1694	1085	1751	1141	91.2	46.2	216	625
38.1 x 305	1031699	9.71	13.0	38.1	1124	819	1187	882	104	53.8	240	313
38.1 x 457	1031715	9.71	15.4	38.1	1428	971	1492	1035	104	53.8	240	465
38.1 x 610	1031733	9.71	17.9	38.1	1749	1139	1813	1203	104	53.8	240	633
44.5 x 457	1031779	12.7	23.0	44.5	1457	1000	1534	1076	118	60.5	253	467
44.5 x 610	1031797	12.7	26.4	44.5	1762	1153	1838	1229	118	60.5	253	619
51.0 x 610	1031813	16.8	37.9	50.8	1922	1313	2011	1402	148	68.3	331	622
63.5 x 610	1031831	27.2	67.4	63.5	2011	1402	2113	1503	165	79.2	350	625
70.0 x 610	1031859	34.0	79.1	69.9	2066	1456	2180	1571	178	82.6	383	626

\*Proof Load is 2.5 times the Working Load Limit. Ultimate Load is 5 times the Working Load Limit. † Mechanical Galvanized

**RIGGING ACCESSORIES**



**HG-227**  
Jaw & Eye

Meets the performance requirements of Federal Specifications FF-T-791b, Type 1 Form 1 - CLASS 8, and ASTM F-1145, except for those provisions required of the contractor. For additional information, see page 476.

- End fittings are Quenched and Tempered or Normalized, bodies heat treated by normalizing.
- Hot Dip galvanized steel.
- Turnbuckles eyes are forged and elongated, by design, to maximize easy attachment in system and minimize stress in the eye. For turnbuckles size 6 mm through 64 mm, a shackle one size smaller can be reeved through eye.
- Forged jaw ends are fitted with bolts and nuts for 6mm through 16mm, and pins and cotters on 19 mm through 70 mm sizes.
- Modified UNJ thread on end fittings for improved fatigue properties.
- Body has UNC threads.
- **TURNBUCKLES RECOMMENDED FOR STRAIGHT OR IN-LINE PULL ONLY.**
- Lock Nuts available for all sizes (see page 198).
- Comprehensive End fitting data on pages 195 & 196.
- Fatigue Rated.
- Meets or exceeds all requirements of ASME B30.26 including identification, ductility, design factor, proof load and temperature requirements. Importantly, these turnbuckles meet other critical performance requirements including fatigue life, impact properties and material traceability, not addressed by ASME B30.26.

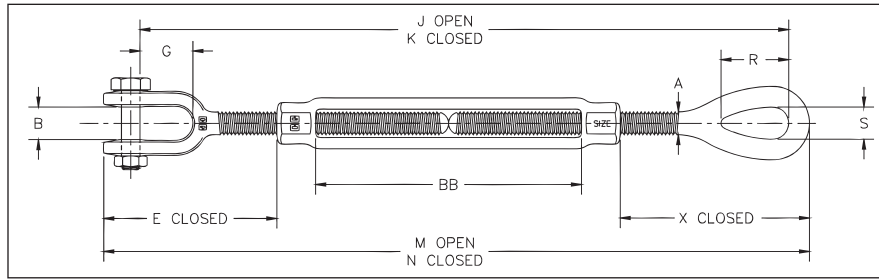

## HG-227 Jaw & Eye

Thread Diameter & Take Up (mm)	HG-227 Stock No.	Working Load Limit (t)*	Weight Each (kg)	Dimensions (mm)											
				A	B	E Closed	G	J Open	K Closed	M Open	N Closed	R	S	X Closed	BB
† 6.35 x 102	1031877	.23	.15	6.35	11.4	42.0	16.1	294	192	312	210	20.6	8.64	44.6	103
† 7.94 x 114	1031895	.36	.24	7.94	12.7	51.2	22.0	343	228	363	249	24.1	11.2	55.8	116
† 9.53 x 152	1031911	.54	.36	9.53	13.5	53.5	21.5	429	277	454	301	28.7	13.5	62.9	155
12.7 x 152	1031939	1.00	.80	12.7	16.3	81.8	27.1	490	338	520	368	35.8	18.0	90.4	153
12.7 x 229	1031957	1.00	1.02	12.7	16.3	81.3	27.1	650	421	680	451	35.8	18.0	89.9	238
12.7 x 305	1031975	1.00	1.21	12.7	16.3	81.3	27.1	802	497	832	528	35.8	18.0	89.9	314
15.9 x 152	1031993	1.59	1.35	15.9	20.1	99.1	33.5	527	374	566	413	45.7	22.4	110	153
15.9 x 229	1032019	1.59	1.69	15.9	20.1	98.8	33.5	688	459	727	498	45.7	22.4	110	239
15.9 x 305	1032037	1.59	1.97	15.9	20.1	98.8	33.5	840	535	879	574	45.7	22.4	110	315
19.1 x 152	1032055	2.36	2.05	19.1	24.6	120	38.5	563	411	612	459	53.1	25.4	130	156
19.1 x 229	1032073	2.36	2.52	19.1	24.6	119	38.5	726	497	774	546	53.1	25.4	129	244
19.1 x 305	1032091	2.36	2.91	19.1	24.6	119	38.5	878	573	927	622	53.1	25.4	129	320
19.1 x 457	1032117	2.36	3.69	19.1	24.6	120	38.5	1183	726	1232	774	53.1	25.4	130	471
22.2 x 305	1032135	3.27	4.13	22.2	29.5	140	44.8	906	601	963	658	60.5	31.8	147	309
22.2 x 457	1032153	3.27	5.28	22.2	29.5	140	44.8	1223	766	1280	822	60.5	31.8	147	473
25.4 x 152	1032171	4.54	4.55	25.4	34.0	155	52.1	636	483	701	548	76.2	36.3	165	157
25.4 x 305	1032199	4.54	6.06	25.4	34.0	155	52.1	941	636	1006	701	76.2	36.3	165	309
25.4 x 457	1032215	4.54	7.58	25.4	34.0	155	52.1	1245	788	1310	853	76.2	36.3	165	462
25.4 x 610	1032233	4.54	9.33	25.4	34.0	154	52.1	1565	956	1630	1021	76.2	36.3	164	631
31.8 x 305	1032251	6.89	9.48	31.8	46.7	205	71.5	1035	730	1117	812	91.2	46.2	216	306
31.8 x 457	1032279	6.89	11.3	31.8	46.7	205	71.5	1340	883	1422	965	91.2	46.2	216	459
31.8 x 610	1032297	6.89	13.1	31.8	46.7	205	71.5	1659	1050	1741	1131	91.2	46.2	216	625
38.1 x 305	1032313	9.71	13.9	38.1	52.3	227	71.4	1080	775	1174	869	104	53.8	240	313
38.1 x 457	1032331	9.71	16.3	38.1	52.3	227	71.4	1384	927	1479	1021	104	53.8	240	465
38.1 x 610	1032359	9.71	18.8	38.1	52.3	227	71.4	1705	1095	1799	1189	104	53.8	240	633
44.5 x 457	1032395	12.7	23.6	44.5	66.0	238	85.0	1406	949	1518	1061	118	60.5	253	467
44.5 x 610	1032411	12.7	27.1	44.5	66.0	238	85.0	1711	1101	1823	1213	118	60.5	253	619
51.0 x 610	1032439	16.8	40.8	50.8	66.5	300	95.0	1846	1236	1980	1370	148	68.3	331	622
63.5 x 610	1032457	27.2	71.7	63.5	77.7	337	113	1932	1323	2100	1490	165	79.2	350	625
70.0 x 610	1032475	34.0	84.6	69.9	93.7	379	106	1982	1373	2176	1566	178	82.6	383	626

\*Proof Load is 2.5 times the Working Load Limit. Ultimate Load is 5 times the Working Load Limit. † Mechanical Galvanized



# Jaw & Jaw Turnbuckles



**HG-228**  
Jaw & Jaw

Meets the performance requirements of Federal Specifications FF-T-791b, Type 1 Form 1 - CLASS 7, and ASTM F-1145, except for those provisions required of the contractor. For additional information, see page 476.

- End fittings are Quenched and Tempered or Normalized, bodies heat treated by normalizing.
- Hot Dip galvanized steel.
- **TURNBUCKLES RECOMMENDED FOR STRAIGHT OR IN-LINE PULL ONLY.**
- Forged jaw ends are fitted with bolts and nuts for 6 mm through 16 mm, and pins and cotters on 19 mm through 70 mm sizes.
- Modified UNJ thread on end fittings for improved fatigue properties.
- Body has UNC threads.
- Lock Nuts available for all sizes (see page 198).
- Comprehensive end fitting data provided on page 196.
- Fatigue Rated.
- Meets or exceeds all requirements of ASME B30.26 including identification, ductility, design factor, proof load and temperature requirements. Importantly, these turnbuckles meet other critical performance requirements including fatigue life, impact properties and material traceability, not addressed by ASME B30.26.

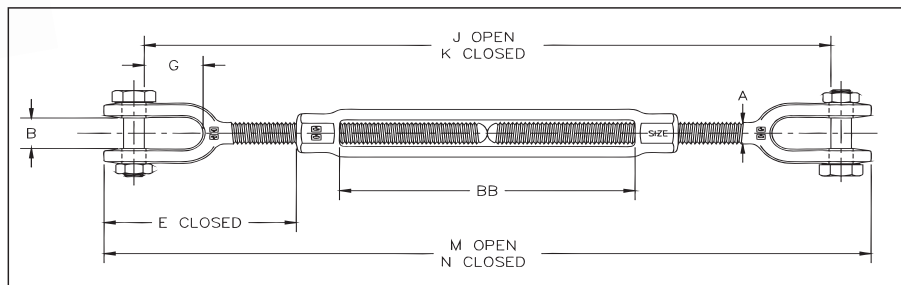

**Fatigue Rated**

## HG-228 Jaw & Jaw

Thread Diameter & Take Up (mm)	HG-228 Stock No.	Working Load Limit (t)*	Weight Each (kg)	Dimensions (mm)								
				A	B	E Closed	G	J Open	K Closed	M Open	N Closed	BB
† 6.35 x 102	1032493	.23	.17	6.35	11.4	42.0	16.1	284	183	309	208	103
† 7.94 x 114	1032518	.36	.25	7.94	12.7	51.2	22.0	332	218	359	244	116
† 9.53 x 152	1032536	.54	.39	9.53	13.5	53.5	21.5	413	260	445	292	155
12.7 x 152	1032554	1.00	.83	12.7	16.3	81.8	27.1	474	321	512	359	153
12.7 x 229	1032572	1.00	1.04	12.7	16.3	81.3	27.1	633	405	671	443	238
12.7 x 305	1032590	1.00	1.23	12.7	16.3	81.3	27.1	786	481	824	519	314
15.9 x 152	1032616	1.59	1.46	15.9	20.1	99.1	33.5	501	349	554	402	153
15.9 x 229	1032634	1.59	1.79	15.9	20.1	98.8	33.5	662	434	715	487	239
15.9 x 305	1032652	1.59	2.08	15.9	20.1	98.8	33.5	815	510	868	563	315
19.1 x 152	1032670	2.36	2.18	19.1	24.6	120	38.5	536	383	601	449	156
19.1 x 229	1032698	2.36	2.65	19.1	24.6	119	38.5	698	470	764	535	244
19.1 x 305	1032714	2.36	3.05	19.1	24.6	119	38.5	851	546	916	612	320
19.1 x 457	1032732	2.36	3.83	19.1	24.6	120	38.5	1155	698	1221	764	471
22.2 x 305	1032750	3.27	4.25	22.2	29.5	140	44.8	880	575	956	651	309
22.2 x 457	1032778	3.27	5.34	22.2	29.5	140	44.8	1197	740	1272	815	473
25.4 x 152	1032796	4.54	4.74	25.4	34.0	155	52.1	605	453	690	538	157
25.4 x 305	1032812	4.54	6.25	25.4	34.0	155	52.1	910	605	995	690	309
25.4 x 457	1032830	4.54	7.77	25.4	34.0	155	52.1	1215	757	1300	843	462
25.4 x 610	1032858	4.54	9.51	25.4	34.0	154	52.1	1535	925	1620	1010	631
31.8 x 305	1032876	6.89	9.94	31.8	46.7	205	71.5	1000	695	1107	802	306
31.8 x 457	1032894	6.89	11.7	31.8	46.7	205	71.5	1305	848	1412	955	459
31.8 x 610	1032910	6.89	13.5	31.8	46.7	205	71.5	1624	1014	1731	1121	625
38.1 x 305	1032938	9.71	14.8	38.1	52.3	227	71.4	1035	731	1160	855	313
38.1 x 457	1032956	9.71	17.2	38.1	52.3	227	71.4	1340	883	1465	1008	465
38.1 x 610	1032974	9.71	19.7	38.1	52.3	227	71.4	1661	1051	1786	1176	633
44.5 x 457	1033018	12.7	24.3	44.5	66.0	238	85.0	1355	898	1503	1045	467
44.5 x 610	1033036	12.7	27.7	44.5	66.0	238	85.0	1660	1050	1807	1198	619
51.0 x 610	1033054	16.8	43.7	50.8	66.5	300	95.0	1769	1159	1949	1339	622
63.5 x 610	1033072	27.2	75.9	63.5	77.7	337	113	1853	1244	2087	1478	625
70.0 x 610	1033090	34.0	90.1	69.9	93.7	379	106	1899	1289	2172	1562	626

\*Proof Load is 2.5 times the Working Load Limit. Ultimate Load is 5 times the Working Load Limit. † Mechanical Galvanized

**RIGGING ACCESSORIES**

## Turnbuckles - Hook End Fittings



**HG -4037**  
Hook End  
Fitting

- Quenched and Tempered or Normalized.
- Hot Dip galvanized steel.
- Hooks are forged with a greater cross sectional area that results in a stronger hook with better fatigue properties.
- Modified UNJ thread for improved fatigue properties.
- Fatigue Rated.

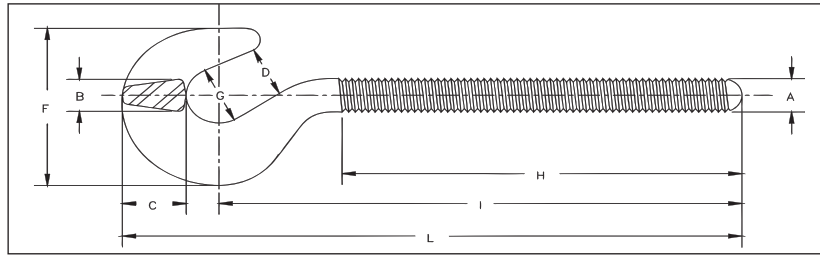

### HG-4037 Hook End Fittings

Shank Diameter & Take Up (mm)	RH Hook Stock No.	LH Hook Stock No.	Working Load Limit (t)	Weight Each (kg)	Dimensions (mm)								
					A	B	C	D	F	G	H	I	L
* 6.35 x 102	1070012	1070539	.18	.04	6.35	6.35	10.4	11.2	32.3	12.7	65.8	87.4	104
* 7.94 x 114	1070030	1070557	.32	.07	7.94	7.87	12.7	12.7	38.1	14.2	76.2	102	122
* 9.53 x 152	1070058	1070575	.45	.12	9.53	9.65	15.5	14.2	44.7	15.7	98.6	127	150
12.7 x 152	1070076	1070593	.68	.27	12.7	12.7	19.8	16.5	57.9	20.8	106	157	187
12.7 x 305	1070110	1070637	.68	.34	12.7	12.7	19.8	16.5	57.9	20.8	183	233	264
15.9 x 305	1070138	1070655	1.02	.48	15.9	16.0	25.4	22.9	71.4	25.4	113	171	210
15.9 x 305	1070174	1070691	1.02	.59	15.9	16.0	25.4	22.9	71.4	25.4	189	248	286
19.1 x 152	1070192	1070717	1.36	.61	19.1	19.1	30.7	24.9	84.6	28.4	116	189	234
19.1 x 305	1070236	1070753	1.36	.97	19.1	19.1	30.7	24.9	84.6	28.4	192	265	310
19.1 x 457	1070254	1070771	1.36	1.14	19.1	19.1	30.7	24.9	84.6	28.4	268	341	386
22.2 x 305	1070272	1070799	1.81	1.42	22.2	22.4	34.8	28.7	96.0	32.0	198	283	334
22.2 x 457	1070290	1070815	1.81	1.64	22.2	22.4	34.8	28.7	96.0	32.0	275	359	410
25.4 x 152	1070316	1070833	2.27	1.80	25.4	25.4	38.9	31.8	108	35.1	129	225	281
25.4 x 305	1070334	1070851	2.27	2.14	25.4	25.4	38.9	31.8	108	35.1	205	301	357

\* Mechanical Galvanized

# Turnbuckles - Eye End Fittings



- Quenched and Tempered or Normalized.
- Hot Dip galvanized steel.
- Turnbuckle eyes are forged elongated, by design, to maximize easy attachment in system and minimize stress in the eye. For turnbuckle sizes 6 mm through 64 mm, a shackle one size smaller can be reeved through eye.
- Modified UNJ thread for improved fatigue properties.
- Fatigue Rated.

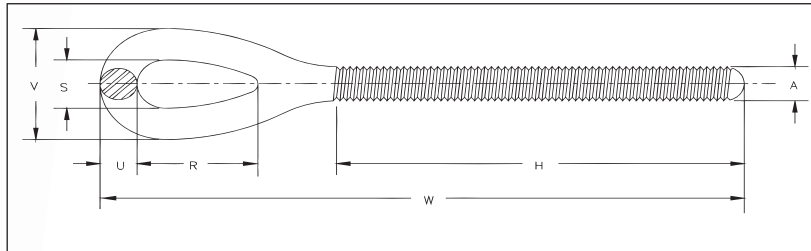

**HG -4037**  
Eye End Fitting



**Fatigue Rated**

## HG-4037 Eye End Fittings

Shank Diameter & Take Up (mm)	RH Eye Stock No.	LH Eye Stock No.	Working Load Limit (t)	Weight Each (kg)	Dimensions (mm)						
					A	H	R	S	U	V	W
*6.35 x 102	1071057	1071672	.23	.03	6.35	65.8	20.6	8.64	5.59	19.8	106
* 7.94 x 114	1071075	1071690	.36	.06	7.94	76.2	24.1	11.2	7.11	25.4	127
* 9.53 x 152	1071093	1071716	.54	.10	9.53	98.6	28.7	13.5	8.64	30.7	155
12.7 x 152	1071119	1071734	1.00	.23	12.7	106	35.8	18.0	11.2	40.4	188
12.7 x 229	1071137	1071752	1.00	.27	12.7	145	35.8	18.0	11.2	40.4	226
12.7 x 305	1071155	1071770	1.00	.31	12.7	183	35.8	18.0	11.2	40.4	264
15.9 x 305	1071173	1071798	1.59	.37	15.9	113	45.7	22.4	12.7	47.8	212
15.9 x 229	1071191	1071814	1.59	.43	15.9	151	45.7	22.4	12.7	47.8	250
15.9 x 305	1071217	1071832	1.59	.49	15.9	189	45.7	22.4	12.7	47.8	289
19.1 x 152	1071235	1071850	2.36	.62	19.1	116	53.1	25.4	16.0	57.4	235
19.1 x 229	1071253	1071878	2.36	.70	19.1	154	53.1	25.4	16.0	57.4	273
19.1 x 305	1071271	1071896	2.36	.78	19.1	192	53.1	25.4	16.0	57.4	311
19.1 x 457	1071299	1071912	2.36	.95	19.1	268	53.1	25.4	16.0	57.4	387
22.2 x 305	1071315	1071930	3.27	1.18	22.2	198	60.5	31.8	19.1	69.9	333
22.2 x 457	1071333	1071958	3.27	1.42	22.2	275	60.5	31.8	19.1	69.9	409
25.4 x 152	1071351	1071976	4.54	1.43	25.4	129	76.2	36.3	22.4	81.0	279
25.4 x 305	1071379	1071994	4.54	1.73	25.4	205	76.2	36.3	22.4	81.0	356
25.4 x 457	1071397	1072010	4.54	2.03	25.4	281	76.2	36.3	22.4	81.0	432
25.4 x 610	1071413	1072038	4.54	2.34	25.4	357	76.2	36.3	22.4	81.0	508
31.8 x 305	1071431	1072056	6.89	3.21	31.8	213	91.2	46.2	28.4	103	411
31.8 x 457	1071459	1072074	6.89	3.68	31.8	289	91.2	46.2	28.4	103	487
31.8 x 610	1071477	1072092	6.89	4.15	31.8	365	91.2	46.2	28.4	103	564
38.1 x 305	1071495	1072118	9.71	4.68	38.1	222	104	53.8	31.8	117	441
38.1 x 457	1071510	1072136	9.71	5.37	38.1	298	104	53.8	31.8	117	517
38.1 x 610	1071538	1072154	9.71	6.05	38.1	375	104	53.8	31.8	117	594
44.5 x 457	1071574	1072190	12.7	7.93	44.5	309	118	60.5	38.1	137	538
44.5 x 610	1071592	1072216	12.7	8.85	44.5	385	118	60.5	38.1	137	614
51.0 x 610	1071618	1072234	16.8	13.1	50.8	396	148	68.3	44.5	157	701
63.5 x 610	1071636	1072252	27.2	21.0	63.5	446	165	79.2	50.8	181	752
70.0 x 610	1071654	1072270	34.0	27.3	69.9	449	178	82.6	57.2	197	785

\* Mechanical Galvanized



## Turnbuckles - Jaw End Fittings

### HG-4037 Jaw End Fittings

- Quenched and Tempered or Normalized.
- Hot dip galvanized steel.
- Forged jaw ends are fitted with bolts and nuts on sizes 6 mm through 16 mm, and pins and cotters on sizes 19 mm through 70 mm.
- Modified UNJ thread for improved fatigue properties.
- Fatigue Rated.

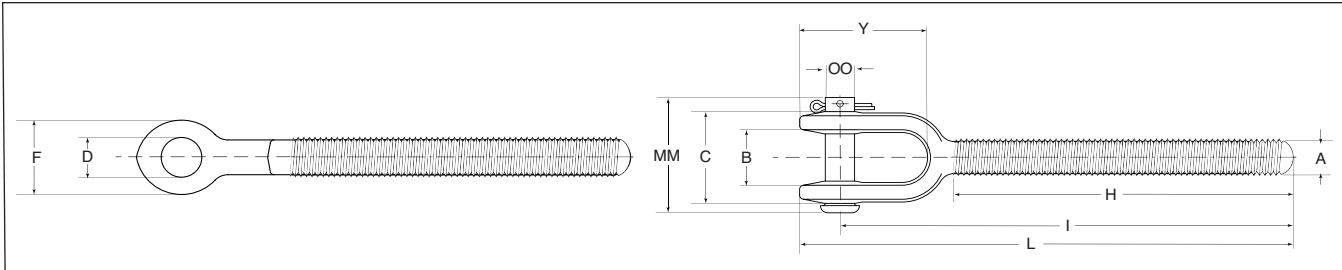

**Fatigue Rated**

### HG-4037 Jaw End Fittings

Shank Diameter & Take Up (mm)	RH Jaw Stock No.	LH Jaw Stock No.	Working Load Limit (t)	Weight Each (kg)	Dimensions (mm)										
					A	B	C	D	F	H	I Nom. Min.	L Nom. Min.	Y	MM	OO Bolt Pin
*6.35 x 102	1072298	1072911	.23	.05	6.35	11.4	23.1	7.62	16.0	65.8	94.5	104	28.7	35.8	6.35
*7.94 x 114	1072314	1072939	.36	.08	7.94	12.7	25.9	7.62	17.5	76.2	112	122	35.3	35.8	6.35
*9.53 x 152	1072332	1072957	.54	.13	9.53	13.5	29.2	9.14	20.6	98.6	134	146	37.3	40.1	7.87
12.7 x 152	1072350	1072975	1.00	.25	12.7	16.3	34.5	10.7	25.4	106	165	180	46.0	47.5	9.40
12.7 x 229	1072378	1072993	1.00	.29	12.7	16.3	34.5	10.7	25.4	145	203	218	46.0	47.5	9.40
12.7 x 305	1072396	1073019	1.00	.33	12.7	16.3	34.5	10.7	25.4	183	242	256	46.0	47.5	9.40
15.9 x 152	1072412	1073037	1.59	.48	15.9	20.1	44.5	14.0	33.3	109	181	201	59.9	62.0	12.7
15.9 x 229	1072430	1073055	1.59	.54	15.9	20.1	44.5	14.0	33.3	148	219	239	59.9	62.0	12.7
15.9 x 305	1072458	1073073	1.59	.59	15.9	20.1	44.5	14.0	33.3	186	257	277	59.9	62.0	12.7
19.1 x 152	1072476	1073091	2.36	.75	19.1	24.6	53.1	17.5	41.4	116	200	225	71.4	65.0	16.0
19.1 x 229	1072494	1073117	2.36	.83	19.1	24.6	53.1	17.5	41.4	154	238	263	71.4	65.0	16.0
19.1 x 305	1072519	1073135	2.36	.92	19.1	24.6	53.1	17.5	41.4	192	276	301	71.4	65.0	16.0
19.1 x 457	1072537	1073153	2.36	1.09	19.1	24.6	53.1	17.5	41.4	268	352	377	71.4	65.0	16.0
22.2 x 305	1072555	1073171	3.27	1.31	22.2	29.5	65.0	20.6	47.8	198	297	325	82.6	78.5	19.1
22.2 x 457	1072573	1073199	3.27	1.47	22.2	29.5	65.0	20.6	47.8	275	373	402	82.6	78.5	19.1
25.4 x 152	1072591	1073215	4.54	1.61	25.4	34.0	70.1	23.9	53.8	129	237	269	94.7	87.4	22.4
25.4 x 305	1072617	1073233	4.54	1.91	25.4	34.0	70.1	23.9	53.8	205	314	345	94.7	87.4	22.4
25.4 x 457	1072635	1073251	4.54	2.22	25.4	34.0	70.1	23.9	53.8	281	390	421	94.7	87.4	22.4
25.4 x 610	1072653	1073279	4.54	2.52	25.4	34.0	70.1	23.9	53.8	357	466	498	94.7	87.4	22.4
31.8 x 305	1072671	1073297	6.89	3.67	31.8	46.7	94.5	30.2	66.8	213	362	401	125	115	28.7
31.8 x 457	1072699	1073313	6.89	4.15	31.8	46.7	94.5	30.2	66.8	289	438	477	125	115	28.7
31.8 x 610	1072715	1073331	6.89	4.62	31.8	46.7	94.5	30.2	66.8	365	514	553	125	115	28.7
38.1 x 305	1072733	1073359	9.71	5.57	38.1	52.3	106	37.3	79.2	222	383	428	134	130	35.1
38.1 x 457	1072751	1073377	9.71	6.26	38.1	52.3	106	37.3	79.2	298	459	504	134	130	35.1
38.1 x 610	1072779	1073395	9.71	6.94	38.1	52.3	106	37.3	79.2	375	535	580	134	130	35.1
44.5 x 457	1072813	1073439	12.7	8.57	44.5	66.0	118	43.7	88.9	309	470	523	159	152	41.4
44.5 x 610	1072831	1073457	12.7	9.50	44.5	66.0	118	43.7	88.9	385	546	599	159	152	41.4
51.0 x 610	1072859	1073475	16.8	16.0	50.8	66.5	142	53.1	106	396	605	670	185	175	50.8
63.5 x 610	1072877	1073493	27.2	25.3	63.5	77.7	148	60.5	143	437	650	739	230	191	57.2
70.0 x 610	1072895	1073518	34.0	32.8	69.9	93.7	167	73.2	155	441	679	781	243	213	69.9

\* Mechanical Galvanized

# Turnbuckles - Body Only



## HG-2510 BODY

- Heat treat by normalizing.
- Hot Dip galvanized.
- UNC threads
- Fatigue Rated.
- Meets the performance requirements of Federal Specifications FF-T-791b, Type 1, Form 1 - Class 2, except for those provisions required by the contractor.

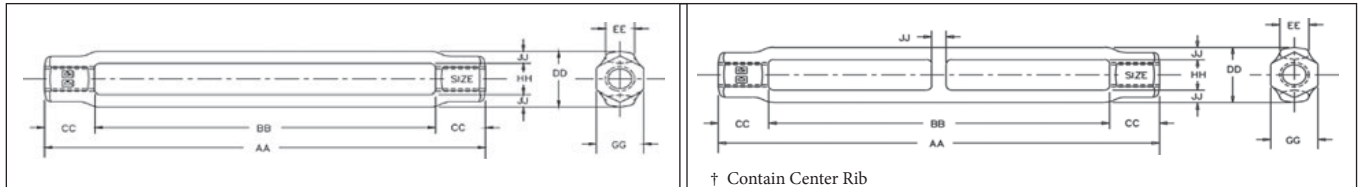

## HG-2510 Body

Shank Diameter & Take Up (mm)	HG-2510 Stock No.	Working Load Limit (t)	Weight Each (kg)	Dimensions (mm)							
				AA	BB	CC	DD	EE	GG	HH	JJ
* 6.35 x 102	1033893	.23	.07	124	103	10.2	18.3	8.64	12.7	9.65	4.32
* 7.94 x 114	1033919	.36	.10	142	116	12.7	20.8	9.65	14.2	11.2	4.83
* 9.53 x 152	1033937	.54	.13	185	155	15.0	22.4	9.65	16.0	12.7	4.83
12.7 x 152	1033955	1.00	.32	196	153	21.1	30.2	17.3	20.6	16.0	7.11
†12.7 x 229	1033973	1.00	.47	280	238	21.1	30.2	17.3	20.6	16.0	7.11
†12.7 x 305	1033991	1.00	.58	356	314	21.1	30.2	17.3	20.6	16.0	7.11
15.9 x 305	1034017	1.59	.50	204	153	25.1	36.3	21.1	25.4	19.1	8.64
†15.9 x 229	1034035	1.59	.72	289	239	25.1	36.3	21.1	25.4	19.1	8.64
†15.9 x 305	1034053	1.59	.89	365	315	25.1	36.3	21.1	25.4	19.1	8.64
19.1 x 152	1034071	2.36	.68	210	156	26.9	44.2	23.9	28.7	23.9	10.2
†19.1 x 229	1034099	2.36	.98	298	244	26.9	44.2	23.9	28.7	23.9	10.2
†19.1 x 305	1034115	2.36	1.21	374	320	26.9	44.2	23.9	28.7	23.9	10.2
†19.1 x 457	1034133	2.36	1.65	525	471	26.9	44.2	23.9	28.7	23.9	10.2
22.2 x 305	1034179	3.27	1.64	371	309	31.2	50.8	28.7	33.3	26.9	11.9
†22.2 x 457	1034197	3.27	2.39	536	473	31.2	50.8	28.7	33.3	26.9	11.9
25.4 x 152	1034213	4.54	1.51	229	157	35.8	62.2	31.8	38.1	31.8	15.2
25.4 x 305	1034231	4.54	2.42	381	309	35.8	62.2	31.8	38.1	31.8	15.2
25.4 x 457	1034259	4.54	3.33	533	462	35.8	62.2	31.8	38.1	31.8	15.2
†25.4 x 610	1034277	4.54	4.47	703	631	35.8	62.2	31.8	38.1	31.8	15.2
31.8 x 305	1034339	6.89	2.59	391	306	42.4	66.5	31.8	47.8	38.1	14.2
31.8 x 457	1034357	6.89	3.44	544	459	42.4	66.5	31.8	47.8	38.1	14.2
†31.8 x 610	1034375	6.89	4.29	710	625	42.4	66.5	31.8	47.8	38.1	14.2
38.1 x 305	1034437	9.71	3.63	402	313	44.5	75.9	38.1	57.2	44.5	15.7
38.1 x 457	1034455	9.71	4.72	554	465	44.5	75.9	38.1	57.2	44.5	15.7
†38.1 x 610	1034473	9.71	5.85	723	633	44.5	75.9	38.1	57.2	44.5	15.7
44.5 x 457	1034552	12.7	7.12	570	467	51.6	91.9	44.5	66.5	53.8	19.1
44.5 x 610	1034570	12.7	8.71	722	619	51.6	91.9	44.5	66.5	53.8	19.1
51.0 x 610	1034632	16.8	11.7	740	622	58.9	105	50.8	76.2	60.5	22.4
63.5 x 610	1034678	27.2	25.4	804	625	89.7	143	69.9	98.6	79.3	31.8
70.0 x 610	1034696	34.0	24.5	804	626	88.9	143	69.9	98.6	114	31.8

\* Mechanical Galvanized

† Contains Center Rib for additional body support.

RIGGING ACCESSORIES

## Stub End Turnbuckles



**HS - 251**  
Stub End  
Turnbuckles

- End fittings are Quenched and Tempered or Normalized, bodies heat treated by normalizing.
- Complete assembly is self colored.
- Reference American Welding Society Specifications for proper welding procedures.
- Meets the performance requirements of Federal Specifications FF-T-791b, Type 1 Form 1 - CLASS 3, and ASTM F-1145, except for those provisions required of the contractor.

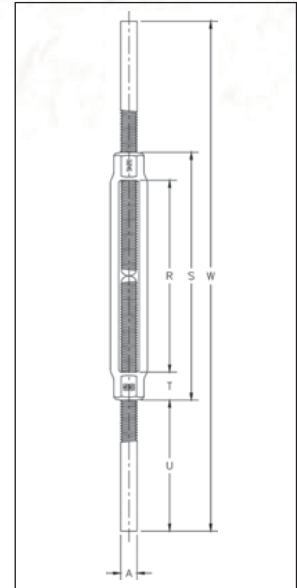

### HS-251 Stub End Turnbuckles

Shank Diameter & Take up (in.)	Shank Diameter & Take Up (mm)	HS-251 Stock No.	Working Load Limit (t)	Weight Each (kg)	Dimensions (mm)					
					A	R	S	T	U	W
3/8 x 6	9.53 x 152	1033143	.54	.34	9.65	152	181	14.2	113	406
1/2 x 6	12.7 x 152	1033161	1.00	.57	12.7	152	190	19.1	108	406
5/8 x 6	15.9 x 152	1033223	1.59	.96	16.0	305	200	23.8	103	406
3/4 x 6	19.1 x 152	1033287	2.36	1.48	19.1	152	209	28.7	111	431
7/8 x 6	22.2 x 152	1033367	3.27	2.17	22.4	152	219	33.2	119	457
1 x 6	25.4 x 152	1033429	4.54	2.88	25.4	152	228	38.1	127	482
1 x 12	25.4 x 305	1033447	4.54	3.99	25.4	304	381	38.1	127	635
1-1/8 x 6	28.6 x 152	1033508	5.62	4.03	28.7	152	231	39.6	125	482
1-1/4 x 6	31.8 x 152	1033526	6.89	4.62	31.8	152	231	39.6	138	508
1-1/4 x 12	31.8 x 305	1033544	6.89	6.17	31.8	304	384	39.6	138	660
1-1/2 x 12	38.1 x 305	1033642	9.71	9.27	38.1	304	400	47.7	137	673

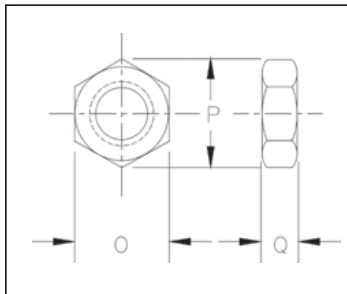

**HG -4060/  
HG -4061**  
Lock Nuts

### HG-4060 / HG-4061 Lock Nuts

Thread Diameter (in.)	Right Hand HG-4060 Stock No.	Left Hand HG-4061 Stock No.	Weight Per 100 (kg)	Dimensions (mm)		
				O	P	Q
1/4	1075115	1075491	.36	11.2	12.7	4.05
5/16	1075133	1075516	.59	12.7	14.2	4.85
3/8	1075151	1075534	.91	14.2	16.3	5.60
1/2	1075197	1075570	1.81	19.1	21.8	7.85
5/8	1075213	1075598	3.18	23.9	26.9	9.65
3/4	1075231	1075614	4.99	28.7	32.0	10.7
7/8	1075259	1075632	7.39	33.3	38.1	12.2
1	1075277	1075650	10.8	38.1	42.9	14.0
1-1/8	1075295	1075678	14.5	38.1	42.9	14.0
1-1/4	1075311	1075696	28.3	47.8	54.0	18.3
1-1/2	1075357	1075730	32.7	57.0	64.5	21.3
1-3/4	1075393	1075776	51	70.0	81.0	25.4
2	1075419	1075794	68	79.0	91.5	28.4
2-1/2	1075455	1075838	150	98.5	114	38.1
2-3/4	1075473	1075856	193	108	125	41.1





**Vitalife® products are the preferred wire rope lubricants in the industry because of their ability to penetrate into wire rope and displace water and contain nants, thus reducing wear and corrosion throughout the rope.**

- Available in a variety of container sizes.
- Provides inner strand preservation and lubricity.
- Allows for easy visual inspection of the ropes.
- Reduces the friction between the strands of the wire rope, thus extending rope life.
- Adheres to surface of strands, forming an outer film which provides excellent corrosive protection.
- Non-tacky (will not attract dust)
- Vitalife® in aerosol form is a regulated dangerous good. See MSDS sheet for shipping instructions.
- Vitalife® Bio-Lube has been developed especially for environmentally friendly applications.
- Vitalife® 500 has been developed exclusively for ski lifts and tramways.
- Vitalife® 600 has been developed exclusively for elevator applications.

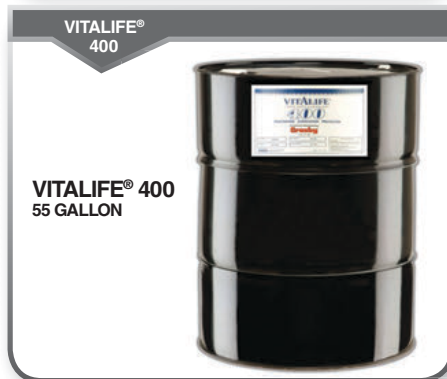

Vitalife® Type	Container Size	Vitalife® Stock No.	Weight Each (kg)
Vitalife® 400 (Standard)	340 grammes	1038946	0.45
	18.9 Litre	1038955	18.6
	208 Litre	1038964	191
Vitalife® 410 BIO-LUBE (Environmentally Friendly)	340 grammes	1039004	0.45
	18.9 Litre	1039013	18.6
	208 Litre	1039022	191
Vitalife® 500 (Ski Lifts and Tramways)	18.9 Litre	1038973	18.6
	208 Litre	1038982	191
	.94 Litre	1038034	0.91
Vitalife® 600 (Elevator Cables)	3.7 Litre	1039037	3.72
	18.9 Litre	1039040	18.6
	208 Litre	1039043	191



### VSP Vitalife® Spray Applicators

- Designed and manufactured to work in the rugged field conditions of the construction industry.
- All applicator seals are specially designed to work with Vitalife® 400 and BIO-LUBE products.

Description	VSP Stock No.	Weight Each (kg)
15 Liter Backpack Sprayer	1039092	5.3



View Video

# FORGED EYE BOLT

## WARNINGS & APPLICATION INSTRUCTIONS

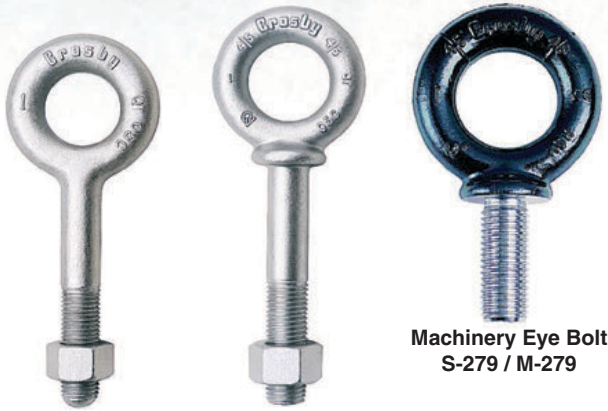

Regular Nut Eye Bolt G-291

Shoulder Nut Eye Bolt G-277

Machinery Eye Bolt S-279 / M-279

### Important Safety Information - Read & Follow

#### Inspection/Maintenance Safety:

- Always inspect eye bolt before use.
- Never use eye bolt that shows signs of wear or damage.
- Never use eye bolt if eye or shank is bent or elongated.
- Always be sure threads on shank and receiving holes are clean.
- Never machine, grind, or cut eye bolt.

#### Assembly Safety:

- Never exceed load limits specified in Table I & Table 2.
- Never use regular nut eye bolts for angular lifts.
- Always use shoulder nut eye bolts (or machinery eye bolts) for angular lifts.
- For angular lifts, adjust working load as follows:

Direction of Pull (from In-Line)	Adjusted Working Load
45 degrees	30% of rated working load
90 degrees	25% of rated working load

- Never undercut eye bolt to seat shoulder against the load.
- Always countersink receiving hole or use washers with sufficient I.D. to seat shoulder.
- Always screw eye bolt down completely for proper seating.
- Always tighten nuts securely against the load.

Size (in.)	Working Load Limit (kg)
1/4	295
5/16	544
3/8	703
1/2	1,179
5/8	2,359
3/4	3,266
7/8	4,808
1	6,033
1-1/8	6,804
1-1/4	9,525
1-1/2	10,890
1-3/4	15,420
2	19,050
2-1/2	29,480

## WARNING

- Load may slip or fall if proper eye bolt assembly and lifting procedures are not used.
- A falling load can seriously injure or kill.
- Read and understand these instructions, and follow all eye bolt safety information presented here.
- Read, understand, and follow information in diagrams and charts below before using eye bolt assemblies.

### Shoulder Nut Eye Bolt – Installation for Angular Loading

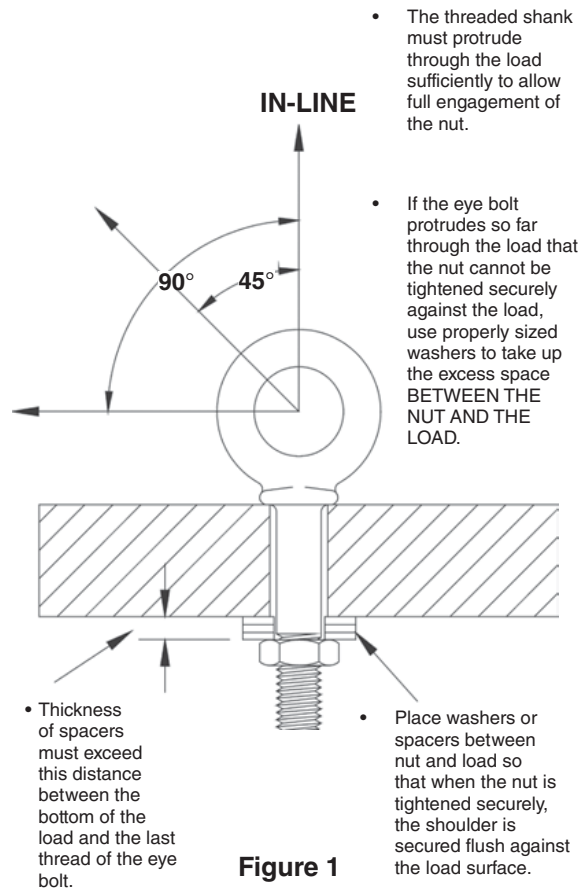
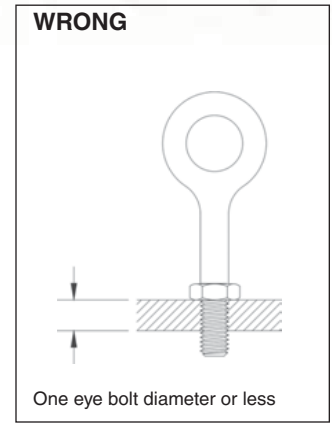
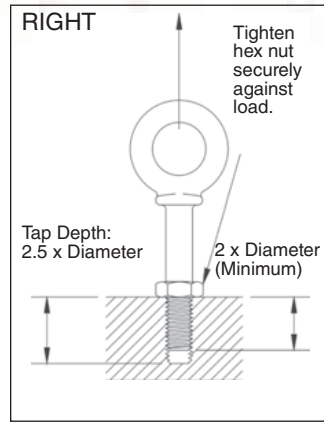
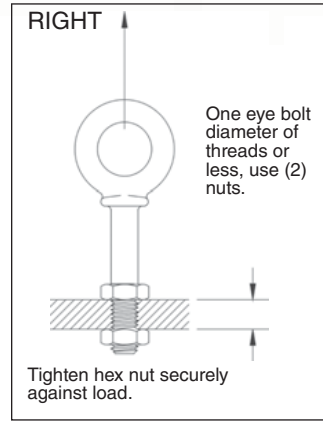
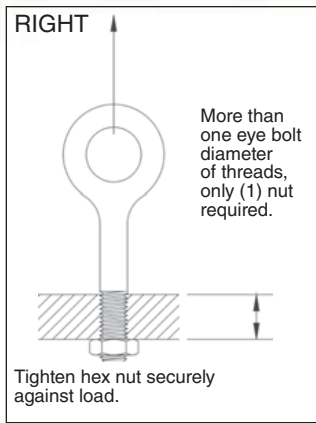

Figure 1

Metric Size	Working Load Limit - kg
m6	200
m8	400
m10	640
m12	1000
m16	1800
m20	2500
m24	4000
m27	5000
m30	6000
m36	8500
m42	14000
m48	17300
m64	29500

## Important – Read and understand these instructions before using eye bolts. Regular Nut & Shoulder Nut Eye Bolt – Installation for In-Line Loading



### Operating Safety

- Always stand clear of load.
- Always lift load with steady, even pull – do not jerk.
- Always apply load to eye bolt in the plane of the eye – not at an angle.
- Never exceed the capacity of the eye bolt—see Table 1 & 2.
- When using lifting slings of two or more legs, make sure the loads in the legs are calculated using the angle from the vertical sling angle to the leg and properly size the shoulder nut or machinery eye bolt for the angular load.

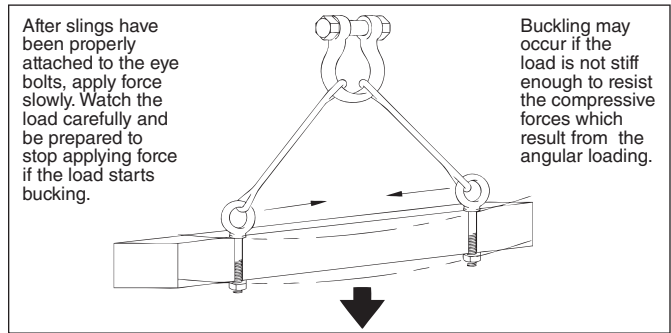
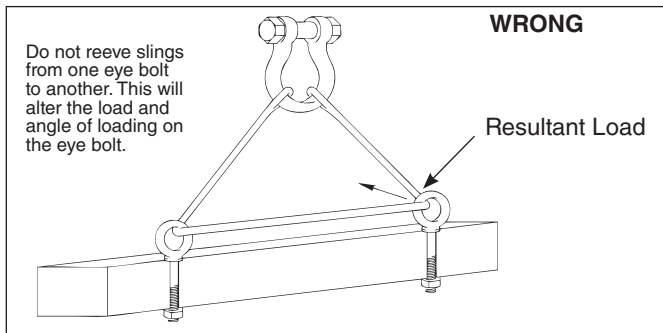

### Machinery Eye Bolt - Installation for In-Line & Angular Loading

These eye bolts are primarily intended to be installed into tapped holes.

1. After the loads on the eye bolts have been calculated, select the proper size eye bolt for the job.

For angular lifts, adjust working load as follows:

Direction of Pull (from In-Line)	Adjusted Working Load
45 degrees	30% of rated working load
90 degrees	25% of rated working load

2. Drill and tap the load to the correct sizes to a minimum depth of one-half the eye bolt size beyond the shank length of the machinery eye bolt.
3. Thread the eye bolt into the load until the shoulder is flush and securely tightened against the load.
4. If the plane of the machinery eye bolt is not aligned with the sling line, estimate the amount of unthreading rotation necessary to align the plane of the eye properly.
5. Remove the machinery eye bolt from the load and add shims (washers) of proper thickness to adjust the angle of the plane of the eye to match the sling line. Use Table 3 to estimate the required shim thickness for the amount of unthreading rotation required.

Eye Bolt Size (in.)	Shim Thickness Required to Change Rotation 90° (in.)	Eye Bolt Size (mm)	Shim Thickness Required to change Rotation 90° (mm)
1/4	.0125	M6	.25
5/16	.0139	M8	.31
3/8	.0156	M10	.38
1/2	.0192	M12	.44
5/8	.0227	M16	.50
3/4	.0250	M20	.62
7/8	.0278	M24	.75
1	.0312	M27	.75
1-1/8	.0357	M30	.88
1-1/4	.0357	M36	1.00
1-1/2	.0417	M42	1.13
1-3/4	.0500	M48	1.25
2	.0556	M64	1.50
2-1/2	.0625	—	—

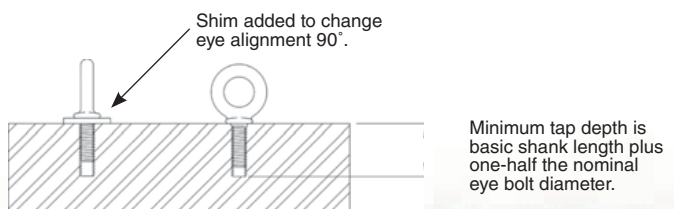



# CROSBY® PIVOT HOIST RING

## WARNINGS & APPLICATION INSTRUCTIONS



### Pivot Hoist Ring Application / Assembly Instructions

- Use pivot hoist ring only with ferrous metal (steel, iron) workpiece.
- After determining the loads on each pivot hoist ring, select the proper size using the Working Load Limit (WLL) ratings in Table 1 for UNC threads or Table 2 for Metric threads (on next page).
- Drill and tap the workpiece to the correct size to a minimum depth of one-half the threaded bolt diameter plus the effective thread projection length (see Table 1 or Table 2, on next page). To select proper bolt and thread sizes see Table 1 or Table 2, on next page.
- Install the pivot hoist ring to recommended torque with a torque wrench making sure the pivot hoist ring body meets the load (workpiece) surface. See rated load limit and bolt torque requirements imprinted on top of the pivot hoist ring body (see Table 1 or Table 2 on next page).
- Never use spacers between the pivot hoist ring body and workpiece surface.
- Always select proper load rated lifting device for use with pivot hoist ring.
- Attach lifting device ensuring free fit to pivot hoist ring bail (lifting ring) (Figure 1).
- Apply partial load and check proper pivot. Ensure load alignment is in the direction of pivot (Figure 4). There should be no interference between load (workpiece) and pivot hoist ring bail (Figure 2).

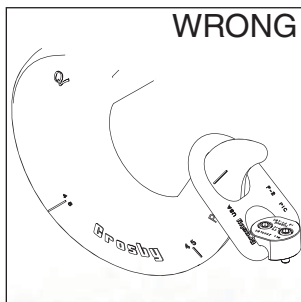

Figure 1

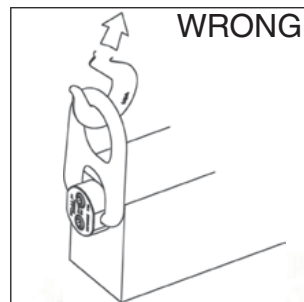

Figure 2

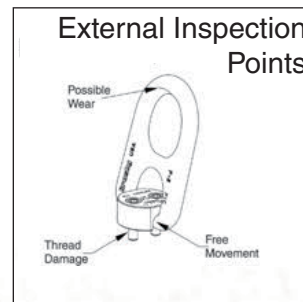

Figure 3

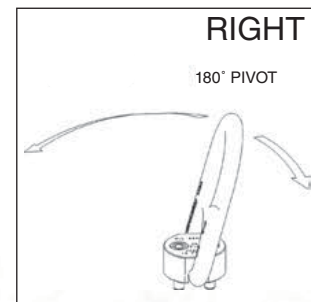

Figure 4

### ⚠ WARNING

- Load may slip or fall if proper Hoist Ring assembly and lifting procedures are not used.
- A falling load can seriously injure or kill.
- Do not use with damaged slings or chain. For inspection criteria see ASME B30.9.
- Never apply load except in line with the pivot direction.
- Use only genuine Crosby bolts as replacements.
- Read and understand these warnings and application instructions

### Pivot Hoist Ring Inspection / Maintenance

- Always inspect pivot hoist ring before use.
- Regularly inspect pivot hoist ring parts (Figure 3).
- Never use pivot hoist ring that shows signs of corrosion, wear or damage.
- Never use pivot hoist ring if bail is bent or elongated.
- Do not use parts showing cracks, nicks or gouges.
- Always be sure threads on bolts and receiving holes are clean, not damaged or worn, and fit properly.
- Always check with torque wrench before using an already installed pivot hoist ring.
- Always make sure there are no spacers (washers) used between pivot hoist ring body and the workpiece surface. Remove any spacers (washers) and retorque before use.
- Always ensure free movement of the bail. The bail should pivot 180 degrees (Figure 4).
- Always be sure total workpiece surface is in contact with the pivot hoist ring body mating surface. Drilled and tapped holes must be 90 degrees to load (workpiece) surface.
- Always make sure that the load is applied in the direction of pivot.

## Operating Safety

- Never exceed the capacity (WLL) of the pivot hoist ring, See Table 1 for UNC threads or Table 2 for Metric threads.
- When using lifting slings of two or more legs, make sure the forces in the legs are calculated using the angle from the horizontal sling angle to the leg and select the proper size pivot hoist ring. When using a multi-leg lifting sling, the pivot hoist ring must be mounted so that the pivot direction is inline with the load applied.

Table 1 HR-100 Pivot Hoist Rings**				
Working Load Limit* (lbs.)	Torque in Ft. Lbs.†	No. of Bolts	Dimensions (in.)	
			Bolt Size††	Effective Thread Projection Length
2,000	7	2	5/16 - 18	0.82
2,500	12	2	3/8 - 16	0.65
5,000	28	2	1/2 - 13	1.40
12,000	28	4	1/2 - 13	1.65
20,000	60	4	5/8 - 11	1.65

Table 2 HR-100M Pivot Hoist Rings**				
Working Load Limit* (Kg)	Torque in Nm†	No. of Bolts	Dimensions (mm)	
			Bolt Size††	Effective Thread Projection Length
900	10	2	M8 - 1.25	19.08
1,150	16	2	M10 - 1.50	14.76
2,150	38	2	M12 - 1.75	34.76
5,100	38	4	M12 - 1.75	42.06
9,000	81	4	M16 - 2.0	39.36

\* Ultimate load is 5 times the working load limit. Individually proof tested to 2-1/2 times the working load limit.

† Tightening torque values shown are based upon threads being clean, dry and free of lubrication.

\*\* Designed to be used with ferrous workpiece only.

†† Only use Crosby high strength replacement bolts. Do not use any other bolts.

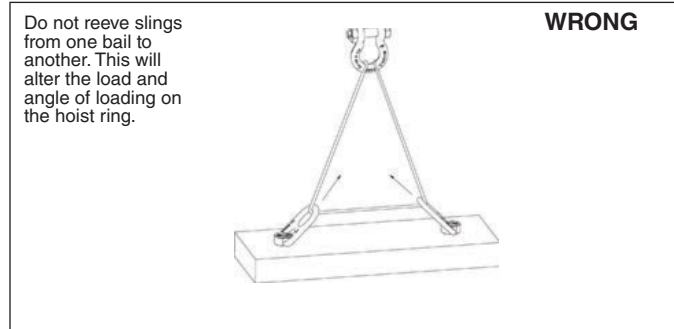
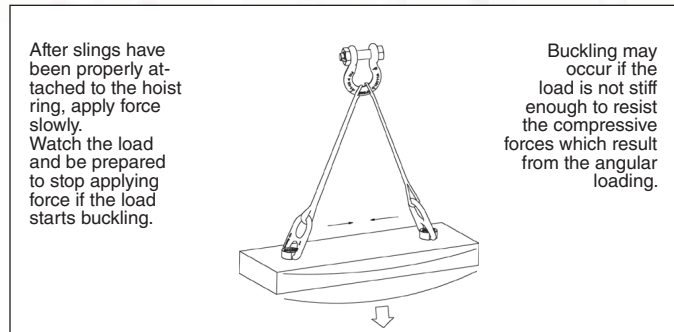

# CROSBY® TRENCH COVER HOIST RING

## WARNINGS & APPLICATION INSTRUCTIONS



HR-500

### Trench Cover Hoist Ring Application / Assembly Instructions

- Use trench cover hoist ring only with ferrous metal (steel, iron) workpiece.
- After determining the loads on each trench cover hoist ring, select the proper size using the Working Load Limit (WLL) ratings in Table 1 (see next page). For proper nut selection, reference trench cover nut welding guidelines (see next page). Nut thickness must equal workpiece thickness.
- For proper welding of nut, reference Nut Welding Guidelines on the following page.
- Always make sure the nut is free of dirt or contaminants before installation of the Trench Cover Hoist Ring. A clean out tool is available from Crosby.
- To install, spin base down flush with workpiece surface and tap one of the lugs on the base with a hammer to tighten; repeat procedure before each use.
- Never use spacers between the trench cover hoist ring base and workpiece surface.
- Always select proper load rated lifting device for use with trench cover hoist ring.
- Attach lifting device ensuring free fit to trench cover hoist ring bail (lifting ring) (Figure 1).
- Apply partial load and check proper rotation and alignment. There should be no interference between load (workpiece) and trench cover hoist ring bail (Figure 2).
- Always ensure free movement of bail. The bail should pivot 180 degrees and swivel 360 degrees (Figure 4).

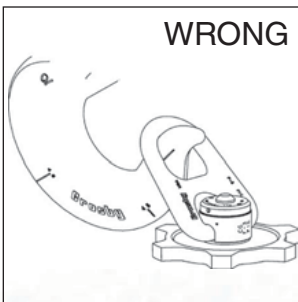

Figure 1

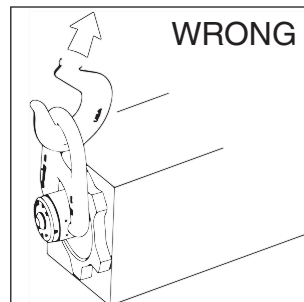

Figure 2

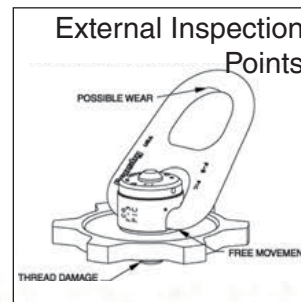

Figure 3

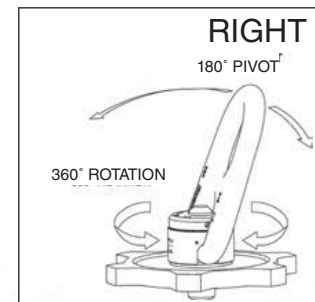

Figure 4

### ⚠ WARNING

- Load may slip or fall if proper Trench Cover Hoist and lifting procedures are not used.
- A falling load can seriously injure or death.
- Do not use with damaged slings or chain. For inspection criteria see ASME B30.9.
- Never apply load except in line with the pivot direction.
- Use only genuine Crosby parts as replacements.
- Read and understand these warnings and application instructions.

### Trench Cover Hoist Ring Inspection / Maintenance

- Always inspect trench cover hoist ring parts before use (Figure 3). Be sure threads on shank and receiving hole are clean, not damaged or worn, and fit properly. A thread gauge is available from Crosby.
- Never use trench cover hoist ring that shows signs of corrosion, wear or damage.
- Never use trench cover hoist ring if bail is bent or elongated.
- Do not use parts showing cracks, nicks or gouges. Always make sure there are no spacers (washers) used between trench cover hoist ring body and the workpiece surface. Remove any spacers (washers) and retighten before use.
- Always be sure total workpiece surface is in contact with the trench cover hoist ring body mating surface.
- Drilled and tapped hole in the weld-in nut must be 90 degrees to load (workpiece) surface. A welding fixture is available from Crosby.
- A visual periodic inspection of the nut to workpiece weld should be performed. Check the weld visually, or use a suitable NDE (Non-Destructive Examination) method if required.



## Operating Safety

- Never exceed the capacity (WLL) of the trench cover hoist ring, see Table 1.
- When using lifting slings of two or more legs, make sure the forces in the legs are calculated using the angle from the horizontal sling angle to the leg and select the proper size trench cover hoist ring.

Working Load Limit (t)*	Dimensions		Weight Each (kg)
	Coil Thread Size (in.) A	Effective Thread Projection Length (mm) B	
2.27	1" - 3.5	25.4	3.6
4.54	1-1/4" - 3.5	25.4	7.3
6.82	1-1/2" - 3.5	38.1	12.7

\* Ultimate load is 5 times the working load limit. Individually proof tested to 2-1/2 times the working load limit.

\*\* Designed to be used with ferrous workpiece only.

## Trench Cover Nut Welding Guidelines

1. Select the correct size trench cover hoist ring to be used. Be sure to calculate the maximum load that will be applied to the trench cover hoist ring. The nut thickness should be equal to the workpiece thickness.
2. Cut a hole in the workpiece per Table 2 below.
3. Insert the trench cover nut into the hole. The trench cover nut should have 1/16" clearance around its outer edge. The surface of the trench cover nut must be parallel and even with the surface of the workpiece (See Figure 5).
4. A welding fixture is available from Crosby for this.
5. Welding is to be performed by a qualified welder using a qualified procedure in accordance with American Welding Society and/or American Society of Mechanical Engineers requirements.

Working Load Limit (t)*	Dimensions (mm)			
	Coil Thread Size (in.)	Nut Diameter K	Trench Cover Hole Diameter L	Nut Thickness = Workpiece Thickness M
2.27	1" - 3.5	76.2	79.2	19
2.27	1" - 3.5	76.2	79.2	22
2.27	1" - 3.5	76.2	79.2	25
4.54	1-1/4" - 3.5	76.2	79.2	19
4.54	1-1/4" - 3.5	76.2	79.2	22
4.54	1-1/4" - 3.5	76.2	79.2	25
4.54	1-1/4" - 3.5	76.2	79.2	32
4.54	1-1/4" - 3.5	76.2	79.2	38
6.82	1-1/2" - 3.5	88.9	91.9	25
6.82	1-1/2" - 3.5	88.9	91.9	32
6.82	1-1/2" - 3.5	88.9	91.9	38

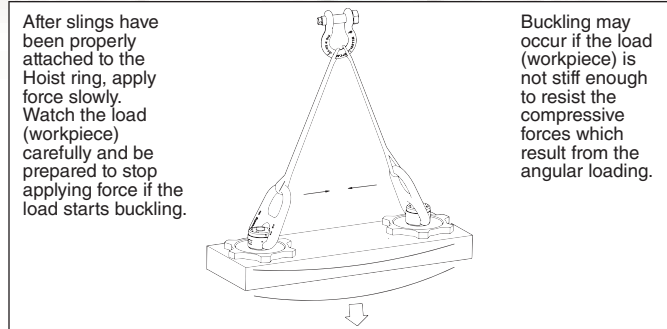

Buckling may occur if the load (workpiece) is not stiff enough to resist the compressive forces which result from the angular loading.

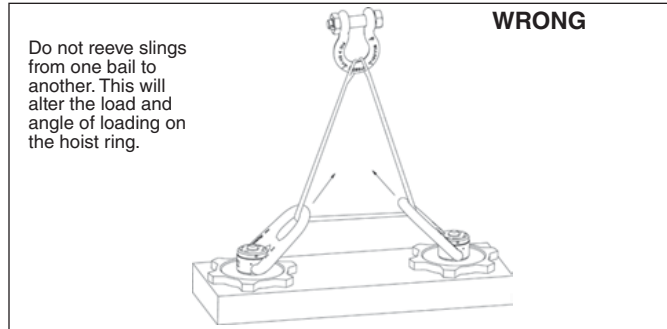

6. When welding to low or medium carbon cover steel, the following suggestions should be included in the qualified procedure.
  - A. Before welding, all weld surfaces must be clean and free from rust, grease, paint, slag and any other contaminants.
  - B. Weld material is to have a minimum tensile strength of 70,000 PSI (such as AWS A5. 1E-7018). Observe the electrode manufacturer's recommendations.
  - C. Completely fill internal bevel created between trench cover nut and the workpiece.
  - D. Do not rapidly cool the weld.
  - E. The surface of the weld must be ground sufficiently so that the trench cover hoist ring will fit flush against the workpiece.
  - F. Using the same procedure, weld the opposite side.
  - G. A thorough inspection of the weld should be performed. No cracks, pitting, inclusions, notches or undercuts are allowed. If doubt exists, use a suitable NDE method, such as magnetic particle or liquid penetrant to verify.
  - H. If repair is required, grind out the defect and re-weld using the original qualified procedure.

**NOTE: For welding to other grades of steel, a qualified weld procedure must be developed.**

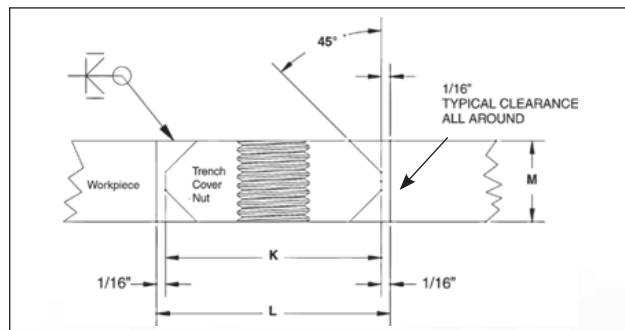

Figure 5



## SIDE PULL HR-1200

### WARNINGS & APPLICATION INSTRUCTIONS



HR-1200

### Hoist Ring Application / Assembly Instruction

- The Crosby side pull swivel hoist ring is designed to accept standard Crosby fittings to facilitate wider slings and quick attachment. In order to use the larger fittings, the load rating on the (shackle) fitting may be greater than the hoist ring frame. **Never exceed the Working Load Limit of the hoist ring frame.**
- Use swivel hoist ring only with a ferrous metal (steel, iron) or non-ferrous (i.e., aluminum) loads (workpiece). Do not leave threaded end of hoist ring in aluminum loads for long time periods due to corrosion.
- After determining the loads on each hoist ring, select the proper size hoist ring using the Working Load Limit ratings in Table 1 for UNC threads and Table 2 for Metric threads (On next page.)
- For Subsea or Metric environment application, use the HR-1200 CT Series Hoist Ring Only.
- Drill and tap the workpiece to the correct size to a minimum depth of one-half the threaded shank diameter plus the threaded shank length.
- Install hoist ring to recommended torque with a torque wrench making sure the bushing flange is fully supported by the load (workpiece) surface. See rated load limit and bolt torque requirements imprinted on hoist ring body (See Table 1 or Table 2).
- Never use spacers between bushing flange and mounting surface.
- Always select proper lifting device for use with Swivel Hoist Ring (See Tables 1 & 2 On next page).
- Attach lifting device ensuring free fit to hoist shackle (See Figure 3).
- Apply partial load and check proper rotation and alignment of shackle. There should be no interference between load (workpiece) and hoist shackle (See Figure 1 and Figure 3).
- The Hoist ring should rotate into normal operating position, with shackle aligned with load as shown in Figure 3. If shackle is oriented as shown in Figure 4, **DO NOT LIFT**.
- Special Note:** when a Hoist Ring is installed with a retention nut, the nut must have full thread engagement and must meet one of the following standards to develop the Working Load Limit (WLL).
  - ASTMA-563 (A) Grade D Hex Thick
  - (B) Grade DH Standard Hex
  - SAE Grade 8 - Standard Hex

### Hoist Ring Inspection / Maintenance

- Always inspect hoist ring before use.
- Regularly inspect hoist ring parts (Figure 2).
- For hoist rings used in frequent load cycles or on pulsating loads, the bolt threads should be periodically inspected by magnetic particle or dye penetrant.
- Do not use part showing cracks, nicks or gouges.
- Repair minor nicks or gouges to hoist frame by lightly grinding until surfaces are smooth. Do not reduce original dimension more than 10%. Do not repair by welding.

### WARNING

- Loads may slip or fall if proper Hoist Ring assembly and lifting procedures are not followed.
- A falling load may cause serious injury or death.
- Install hoist ring bolt to torque requirements listed in tables.
- The side pull hoist ring frame will be only one part of a lifting system with several components (i.e., shackles and slings). Never exceed the Working Load Limit of the hoist ring frame.
- Do not use damaged slings or chain. For inspection criteria, see ASME B30.9.
- Read and understand these instructions before using hoist ring.
- Use only genuine Crosby parts as replacements.

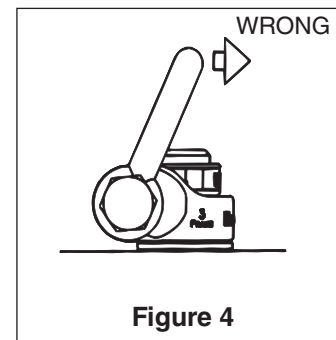
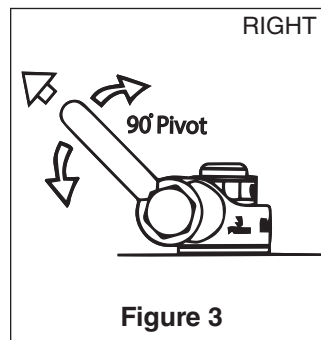
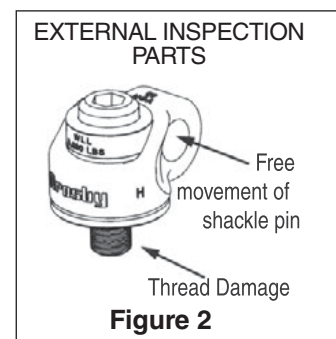
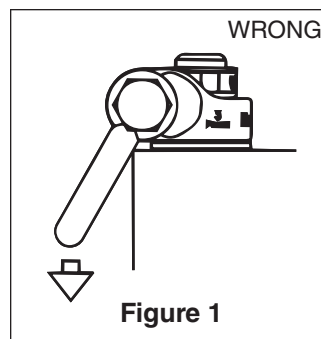

- Never use hoist ring that shows signs of corrosion, wear or damage.
- Never use hoist ring if components are bent or elongated.
- Always be sure threads on bolt and receiving tapped holes are clean, undamaged, and fit properly.
- Always check with torque wrench before using an already installed hoist ring.
- Always make sure there are no spacers (washers) used between bushing flange and the mounting surface. Remove any spacers (washers) and retorque before use.
- Always ensure free movement of shackle. The shackle should pivot 90° and the hoist ring should swivel 360° (See Figure 3).
- Always be sure total workpiece surface is in contact with hoist ring bushing mating surface. Drilled and tapped hole must be 90° to load (workpiece) surface.

## OPERATING SAFETY



- Never exceed the capacity of the hoist ring, see Table 1 for UNC threads and Table 2 for Metric threads.
- When using lifting slings of two or more legs, make sure the forces in the legs are calculated using the angle from the horizontal sling angle to the leg and select the proper size swivel hoist ring to allow for the angular forces.

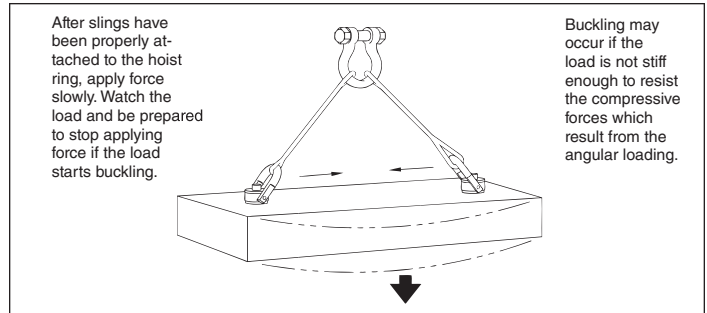
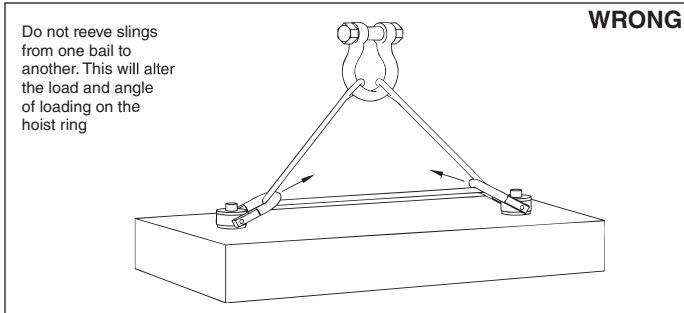

**HR1200 UNC Threads      TABLE 1**

Frame Size	Working Load Limit * (lbs.)	Hoist Ring Bolt Torque in Ft. Lbs. †	Bolt Size ‡ (in.)	Effective Thread Projection Length (in.)	Recommended Shackles	
					Red Pin® Shackles 209, 210, 213 215, 2130, 2150	Red Pin® Web Shackles S-281
1	650††	7	5/16 - 18 x 1.5	.59	1/2" - (2) 5/8" - (3-1/4)	2" - (3-1/4)
	800††	12	3/8 - 18 x 1.5	.59		
2	2000	28	1/2 - 13 x 2.0	.71	5/8" - (3-1/4) 3/4" - (4-3/4)	2" - (3-1/4) 1-1/2" - (4-1/2)
	2000††	28	1/2 - 13 x 2.5	1.21		
	3000	60	5/8 - 11 x 2.0	.71		
	3000††	60	5/8 - 11 x 2.75	1.46		
3	5000	100	3/4 - 10 x 2.75	1.46	7/8" - (6-1/2)	2" - (6-1/4)
	5000††	100	3/4 - 10 x 3.5	1.63		
	6500	160	7/8 - 9 x 2.5	.90		
	6500††	160	7/8 - 9 x 3.5	1.65		
	8000	230	1 - 8 x 3.0	1.15		
	8000††	230	1 - 8 x 4.0	2.15		
4	14000	470	1-1/4 - 7 x 4.5	2.22	1" - (8-1/2) 1-1/8" - (9-1/2) 1-1/4" - (12)	3" - (8-1/2)
5	17200	800	1-1/2 - 6 x 6.5	2.98	1-3/8" - (13-1/2) 1-1/2" - (17) 1-3/4" - (25)	—
	29000	1100	2 - 4-1/2 x 6.5	2.98		

**HR1200M Metric Threads      TABLE 2**

Frame Size	Working Load Limit * (kg)	Hoist Ring Bolt Torque Nm †	Bolt Size ‡ (mm)	Effective Thread Projection Length (mm)	Recommended Shackles	
					Red Pin® Shackles 209, 210, 213 215, 2130, 2150	Red Pin® Web Shackles S-281
1	300	10	M8 x 1.25 x 40	16.9	1/2" - (2) 5/8" - (3-1/4)	2" - (3-1/4)
	400	16	M10 x 1.5 x 40	16.9		
2	1000	31	M12 x 1.75 x 50	17.2	5/8" - (3-1/4) 3/4" - (4-3/4)	2" - (3-1/4) 1-1/2" - (4-1/2)
	1400	81	M16 x 2.00 x 60	27.2		
3	2250	136	M20 x 2.50 x 75	28.1	7/8" - (6-1/2)	2" - (6-1/4)
	3500	312	M24 x 3.00 x 80	33.1		
4	6250	637	M30 x 3.5 x 120	65.1	1" - (8-1/2) 1-1/8" - (9-1/2) 1-1/4" - (12)	3" - (8-1/2)
5	7750	1005	M36 x 4.0 x 150	60.6	1-3/8" - (13-1/2) 1-1/2" - (17) 1-3/4" - (25)	—
	10000	1005	M42 x 4.5 x 160	70.6		
	13000	1350	M48 x 5.0 x 160	70.6		

Designed to be used with Ferrous workpiece only

\* Ultimate load is 5 times the Working Load Limit. Individually proof tested to 2-1/2 times the Working Load Limit.

† Tightening torque values shown are based upon threads being clean, dry and free of lubrication.

†† Long bolts are designed to be used with soft metal (i.e., aluminum) workpiece. While the long bolts may also be used with ferrous metal (i.e., steel & iron) workpieces, short bolts are designed for ferrous workpieces only.

‡ Bolt specification is a Grade 8 Alloy socket head cap screw to ASTM A574. All threads are UNC - 3A.

‡‡ Bolt specification is a Grade 12.9 Alloy socket head cap to DIN 912. All threads are metric (ASME/ANSI B18.3.1m).

**RIGGING ACCESSORIES**



# CROSBY® WELD-ON PIVOTING LINK

## WARNING & APPLICATION INSTRUCTIONS



**⚠ WARNING**

- Loads may disengage from link if proper welding, assembly, and lifting procedures are not used.
- A falling load may cause serious injury or death.
- Do not use with damaged slings or chain. For sling inspection criteria see ASME B30.9.
- Read and understand these instructions before welding on, or using the pivoting link.

### Important Safety Information - Read and Follow

- Use weld-on pivoting link only with ferrous metal (steel) workpiece.
- After determining the loads on each weld-on pivoting link, select the proper size using the Working Load Limit (WLL) ratings in Table 1 on next page.
- Always make sure the weld-on pivoting link and mounting surface is free of dirt or contaminants before installation.
- Never use spacers between the weld-on pivot link and mounting surface.
- Always select proper load rated lifting device for use with weld-on pivoting link.
- Attach lifting device ensuring free movement of weld-on pivoting link bail (Figure 1).
- Apply partial load and check proper alignment. There should be no interference between load (workpiece) and weld-on pivoting link (Figure 2).
- Always ensure free movement of bail. The bail should pivot 180 degrees (Figure 4).
- The support structure that the pivot link is attached to must be of suitable size, composition and quality to support the anticipated loads of all operating positions. The required support structure thickness for a given application is dependent on variables such as unsupported length and material strength, and should be determined by a qualified individual.
- Never repair, alter, rework or reshape the pivoting link bail by welding, heating, burning or bending.

## Weld-on Pivoting Link Inspection / Maintenance

- Always inspect weld-on pivoting link before use.
- Regularly inspect weld-on pivoting link parts (Figure 3).
- Never use weld-on pivoting link that shows signs of corrosion, wear or damage.
- Never use weld-on pivoting link if bail is bent or elongated.
- Do not use part showing cracks, nicks or gouges.
- Always make sure there are no spacers used between weld-on pivoting link and the mounting surface.
- Always be sure workpiece surface is in total contact with the weld-on pivoting link base mating surface.
- Always inspect the weld-on pivoting link bail and base for wear.
- A visual periodic inspection of the weld should be performed. Check the weld visually, or use a suitable NDE method if required.

## Operating Safety

- Never exceed the capacity (WLL) of the weld-on pivoting link (Table 1, next page).
- Never apply load except in line with the pivot direction (Figure 4).
- When using lifting slings of two or more legs, make sure the forces in the legs are calculated using the angle from the horizontal sling angle to the leg and select the proper size link.

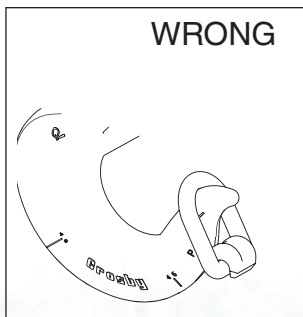
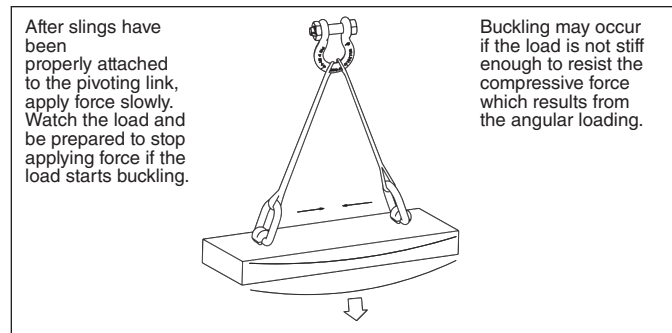
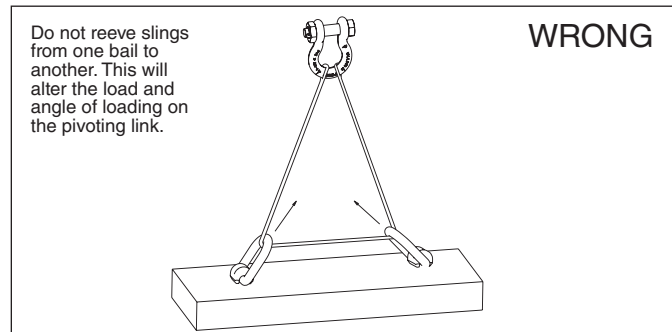

Figure 1

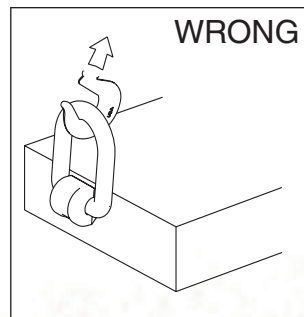

Figure 2

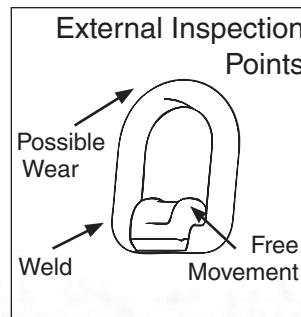

Figure 3

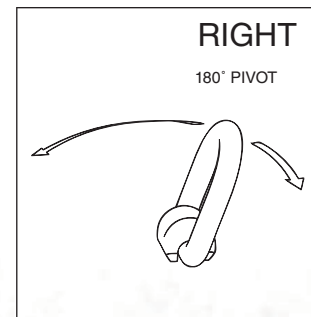

Figure 4

rev 2

## Weld-on Pivoting Link Welding Guidelines



1. Select the correct size weld-on pivoting link to be used. Be sure to calculate the maximum load that will be applied to the weld-on pivoting link.
2. Place the weld-on pivoting link onto the mounting surface. The bottom of the link base must be parallel and even with the mounting surface.
3. Welding is to be performed by a qualified welder using a qualified procedure in accordance with American Welding Society and/or American Society of Mechanical Engineers requirements. Always follow your country or local mandatory regulations or codes.
4. The following welding recommendations should be included in the qualified procedure for welding to low or medium carbon plate steel. For welding to other grades of steel, a qualified weld procedure must be developed.
  - A. Weld material is to have a minimum tensile strength of 70,000 PSI (such as AWS A5.1 E-7018). Observe the electrode manufacturer's recommendations. Completely fill internal fillet created between weld-on pivoting link base and mounting surface.
  - B. Before welding, all weld surfaces must be clean and free from rust, grease, paint, slag and any other contaminants.
  - C. Fillet weld leg size should be minimum shown in Table 1. Weld profiles to be in accordance with AWS. Weld size is measured by length of leg.
  - D. Welding should be carried out in a minimum of two passes to ensure adequate root penetration at the base of the pivoting link.
  - E. Weld full length of "D" dimension on both sides of link base (Figure 5).
  - F. Do not weld close to the bail. After welding, ensure bail pivots full 180° without interfering with the weld.
  - G. Do not rapidly cool the weld.
  - H. The ends of the weld must be ground sufficiently so that the weld-on pivoting link will fit flush against the mounting surface.
  - I. A thorough inspection of the weld should be performed. No cracks, pitting, inclusions, notches or undercuts are allowed. If doubt exists, use a suitable NDE method, such as magnetic particle or liquid penetrant to verify.
  - J. If repair is required, grind out the defect and re-weld using the original qualified procedure.

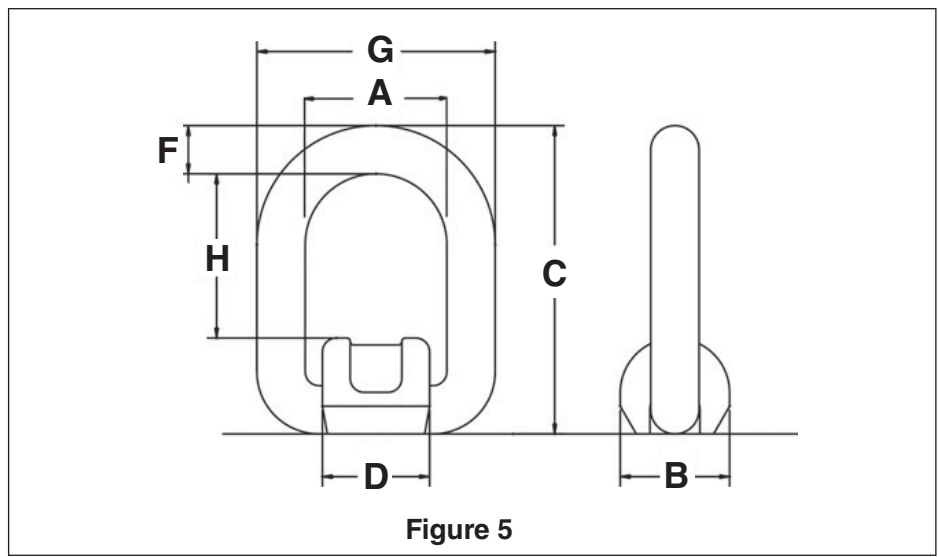

Figure 5

Table 1 S-265 Weld-on Pivoting Links *											
Stock Number	Working Load Limit (t)		Dimensions (mm)							Minimum Fillet Weld Size	Weight Each (kg)
	Design Factor 5:1	Design Factor 4:1	A	B	C	D	F	G	H		
1290740	1	1.2	40	36	83	35	13	66	42	3	.40
1290768	2.5	3.2	45	44	99	42	18	81	48	3	.60
1290786	4	5	55	50	123	49	22	99	57	6	1.20
1290802	6.4	8	70	64	144	64	26	122	67	6	2.40
1290820	12	15	97	90	193	86	34	165	94	8	5.90

\*Designed to be used with ferrous workpiece only.

# CROSBY SWIVEL HOIST RING

## WARNING & APPLICATION INSTRUCTIONS



**HR-125/SS-125**  
(Red Washer)  
**HR-125M**  
**SS-125M**  
(Silver Washer)



**HR-1000**  
(Red Washer)  
**HR-1000M**  
(Silver Washer)  
**HR-1000CT**  
(Blue Washer)



**HR-125C**



**HR-125W**

### Hoist Ring Application Assembly Safety

- Use swivel hoist ring only with a ferrous metal (steel, iron) or soft metal (i.e., aluminum) load (workpiece). Do not leave threaded end of hoist ring in aluminum loads for long time periods due to corrosion.
- For subsea or marine environment applications, use the HR-1000CT series Hoist Ring only.
- After determining the loads on each hoist ring, select the proper size hoist ring using the Working Load Limit ratings in Tables 1, 2, 3, 6 and 7 for UNC threads and Tables 5 and 8 for Metric threads (on next page).
- Drill and tap the workpiece to the correct size to a minimum depth of one-half the threaded shank diameter plus the threaded shank length. See rated load limit and bolt torque requirements imprinted on top of the swivel trunnion (See Table 1 through Table 8 on next page).
- When a hoist ring is used in a side load application, ensure equal loading on the pins by aligning the bail as shown in (Fig. 5).
- Always be sure total workpiece surface is in contact with hoist ring bushing mating surface. Drilled and tapped hole must be 90 degrees to load (workpiece) surface.
- Install hoist ring to recommended torque with a torque wrench making sure the bushing flange meets the load (workpiece) surface.
- Never use spacers between bushing flange and mounting surface.
- Always select proper load rated lifting device for use with Swivel Hoist Ring.
- Attach lifting device ensuring free fit to hoist ring bail (lifting ring) (Fig. 1).
- Apply partial load and check proper rotation and alignment. There should be no interference between load (workpiece) and hoist ring bail (Fig. 2).
- Special Note: When a Hoist Ring is installed with a retention nut, the nut must have a full thread engagement and must meet one of the following standards to develop the Working Load Limit (WLL).

#### 1. ASTM A-563

- (A) Grade D Hex Thick
- (B) Grade DH Standard Hex

#### 2. SAE Grade 8 — Standard Hex

### Hoist Ring Inspection / Maintenance

- Always inspect hoist ring before use.
- Regularly inspect hoist ring parts (Fig.3).
- Never use hoist ring that shows signs of corrosion, wear or damage.
- Never use hoist ring if bail is bent or elongated.
- Always be sure threads on shank and receiving hole are clean, not damaged, and fit properly.
- Always check with torque wrench before using an already installed hoist ring.

- Always make sure there are no spacers (washers) used between bushing flange and the mounting surface. Remove any spacers (washers) and retorque before use.
- Prior to loading always ensure free movement of bail. The bail should pivot 180 degrees and swivel 360 degrees (Fig. 4).

### WARNING

- Loads may slip or fall if proper Hoist Ring assembly and lifting procedures are not used.
- A falling load may cause serious injury or death.
- Install hoist ring bolt to torque requirements listed in tables 1, 2, 3, 4, 5, 6 & 7 for the HR-125, HR-1000, HR125C, HR-1000CT, HR-125M, HR-1000M and HR125W, SS-125 and SS-125M respectively.
- Web sling HR-125W spool bolt must be securely tightened in place. The jam nut must then be securely tightened onto the connecting bolt, see Table 5, last column.
- Read, understand and follow all instructions and chart information.
- Do not use with damaged slings, chain, or webbing. For inspection criteria see ASME B30.9.
- Use only genuine Crosby parts as replacements.
- HR-125C chain connecting pin must be properly secured with the locking pin into the clevis ear.
- Before uses tighten bolt first, then tighten nut (HR-125W).

### Operating Safety

- Never exceed the capacity of the swivel hoist ring, see Tables 1, 2, 3, 5 and 6 for UNC threads and Tables 4 and 7 for Metric threads. (See next page for tables.)
- When using lifting slings of two or more legs, make sure the forces in the legs are calculated using the angle from the horizontal sling angle to the leg and select the proper size swivel hoist ring to allow for the angular forces.

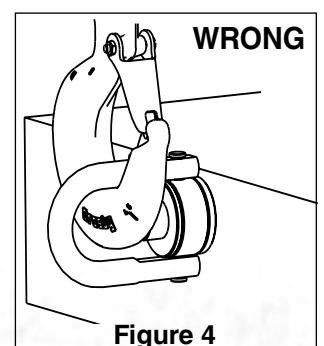
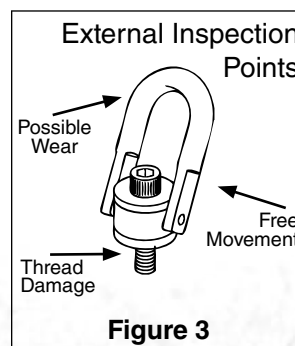
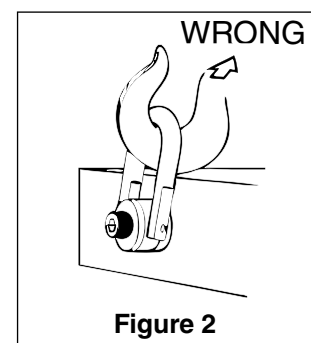
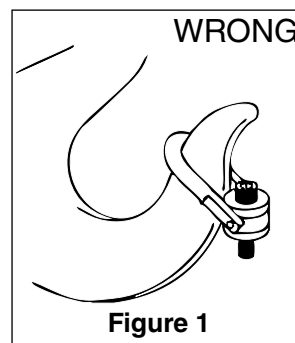
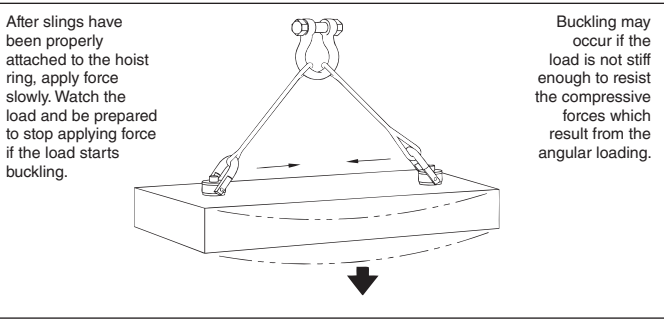
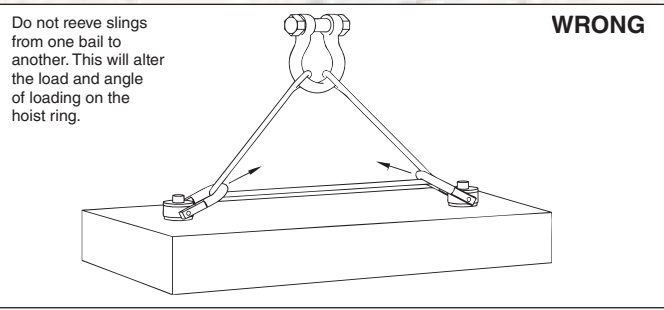





Table 1					
Working Load Limit* 5:1 (lbs.)	Hoist Ring Bolt Torque Ft.-lbs. †	HR-125		HR-1000	
		Bolt Size ‡ (in.)	Effective Thread Project. Length (in.)	Bolt Size ‡ (in.)	Effective Thread Project. Length (in.)
800 ††	7	5/16 - 18 x 1.50	.58	5/16 - 18 x 1.50	.52
1000 ††	12	3/8 - 16 x 1.50	.58	3/8 - 16 x 1.50	.52
2500	28	1/2 - 13 x 2.00	.70	1/2 - 13 x 2.25	.69
2500 ††	28	1/2 - 13 x 2.50	1.20	1/2 - 13 x 2.75	1.19
4000	60	5/8 - 11 x 2.00	.70	5/8 - 11 x 2.25	.69
4000 ††	60	5/8 - 11 x 2.75	1.45	5/8 - 11 x 3.00	1.44
5000	100	3/4 - 10 x 2.25	.95	3/4 - 10 x 2.50	.94
5000 ††	100	3/4 - 10 x 2.75	1.45	3/4 - 10 x 3.00	1.44
7000 Ω	100	3/4 - 10 x 2.75	.89	3/4 - 10 x 3.00	.85
7000 ††Ω	100	3/4 - 10 x 3.50	1.64	3/4 - 10 x 3.50	1.35
8000	160	7/8 - 9 x 2.75	.89	7/8 - 9 x 3.00	.85
8000 ††	160	7/8 - 9 x 3.50	1.64	7/8 - 9 x 3.50	1.35
10000	230	1 - 8 x 3.00	1.14	1 - 8 x 3.50	1.35
10000 ††	230	1 - 8 x 4.00	2.14	1 - 8 x 4.50	2.35
15000	470	1-1/4 - 7 x 4.50	2.21	1-1/4 - 7 x 5.00	2.09
24000	800	1-1/2 - 6 x 6.75	2.97	1-1/2 - 6 x 5.50	2.59
30000	1100	2 - 4-1/2 x 6.75	2.97	—	—
50000	2100	2-1/2 - 4 x 8.00	4.00	—	—
75000	4300	3 - 4 x 10.50	5.00	—	—
100000	5100	3-1/2 - 4 x 13.00	7.00	—	—



Ω Ultimate Load is 4.5 times Working Load Limit for 7000# Hoist Ring when tested in 90° orientation. All sizes are individually proof tested to 2-1/2 times the Working Load Limit. †, ††, ‡ (See footnotes to the right of Table on next page)

Table 2				
HR-125C Swivel Hoist Ring to Grade 8 Chain				
Working Load Limit ** 4:1 (lbs.)	Hoist Ring Bolt Torque in Ft.-lbs. †	Bolt Size (in.) ‡	Effective Thread Projection Length (in.)	Spectrum 8 Chain Size (in. - mm)
4500	60	5/8 - 11 x 2.00	.71	1/4 - 5/16 - 7 - 8
4500 ††	60	5/8 - 11 x 2.75	1.46	1/4 - 5/16 - 7 - 8
7100	100	3/4 - 10 x 2.75	.90	3/8 - 10
7100 ††	100	3/4 - 10 x 3.50	1.65	3/8 - 10
12000	230	1 - 8 x 3.00	1.15	1/2 - 13
12000 ††	230	1 - 8 x 4.00	2.15	1/2 - 13
18100	470	1-1/4 - 7 x 4.50	2.22	5/8 - 16

Table 3			
HR-1000CT			
Working Load Limit 5:1 (lbs.)****	Hoist Ring Bolt Torque in Ft.-lbs. †	Bolt Size (in.) Δ	Effective Thread Projection Length (in.)
2000	28	1/2 - 13 x 2.25	.69
3200	60	5/8 - 11 x 2.25	.69
5400	100	3/4 - 10 x 3.00	.85
7200	160	7/8 - 9 x 3.00	.85
10000	230	1 - 8 x 3.50	1.35
13500	470	1 1/4 - 7 x 5.00	2.09
20000	800	1 1/2 - 6 x 5.50	2.59
28000	1100	2 - 4.5 x 7.50	3.21

Table 4				
Working Load Limit (kg)****		HR-1000MCT		
Design Factor 5:1	Design Factor 4:1	Hoist Ring Bolt Torque in (Nm) †	Bolt Size (mm) ‡	Effective Thread Projection Length (mm)
825	1030	38	M12 x 1.75 x 55	15.6
1350	1690	81	M16 x 2.00 x 65	25.5
2250	2810	136	M20 x 2.50 x 80	25.3
3175	3970	312	M24 x 3.00 x 90	35.4
5450	6810	637	M30 x 3.50 x 140	65.9
7450	9310	1005	M36 x 4.00 x 130	56.3
13250	16560	1350	M48 x 5.00 x 180	50.7

Table 5						
Working Load Limit (kg)***		Hoist Ring Bolt Torque in Nm †	HR-125M		HR-1000M	
Design Factor 5:1	HR-125M Design 4:1		Bolt Size ‡ (mm)	HR-125M Effective Thread Projection Length (mm)	Bolt Size ‡ (mm)	HR-1000M Effective Thread Projection Length (mm)
400	500	10	M 8 X 1.25 X 40	16.9	M 8 X 1.25 X 40	15.2
450	550	16	M 10 X 1.50 X 40	16.9	M 10 X 1.50 X 40	15.2
1050	1300	38	M 12 X 1.75 X 50	17.2	M 12 X 1.75 X 55	15.5
1900	2400	81	M 16 X 2.00 X 60	27.2	M 16 X 2.00 X 65	25.5
2150	2700	136	M 20 X 2.50 X 65	31.2	M 20 X 2.50 X 70	30.5
3000	3750	136	M 20 X 2.50 X 75	28.1	M 20 X 2.50 X 80	25.4
4200	5250	312	M 24 X 3.00 X 80	33.1	M 24 X 3.00 X 90	35.4
7000	8750	637	M 30 X 3.50 X 120	65.1	M 30 X 3.50 X 140	66.2
11000	13750	1005	M 36 X 4.00 X 150	60.6	M 36 X 4.00 X 150	56.2
12500	15600	1005	M 42 x 4.50 x 160	70.6	—	—
13500	16900	1350	M 48 x 5.00 x 160	101	—	—
22300	27900	2847	M 64 x 6.00 x 204	101	—	—
31500	39400	5830	M 72 x 6.00 x 265	132	—	—
44600	55800	6914	M 90 x 6.00 x 330	177	—	—

**RIGGING ACCESSORIES**

Table 6								
HR-125W Swivel Hoist Ring to Webbing								
HR-125W Web Sling				HR-125W Working Load Limit 5:1 (tons) *	Hoist Ring Bolt Torque in Ft. Ft-lbs. †	Bolt Size (in.) ‡	Effective Thread Projection Length (in.)	Torque in Ft.-lbs. Spool bolt and nut †††
Round Sling Size (in.)	Web Width (in.)	Eye Width (in.)	Ply. (in.)					
1 & 2	2	2	2	3-1/4	100	3/4 - 10 x 2.75	.90	90
1 & 2	2	2	2	3-1/4	100	3/4 - 10 x 3.50	1.65	90
3	3	1.5	2	4-1/2	230	1 - 8 x 3.00	1.15	110
3	3	1.5	2	4-1/2	230	1 - 8 x 4.00	2.15	110
4	4	2	2	6-1/4	470	1-1/4 - 7 x 4.50	2.22	130

† Tightening torque values shown are based upon threads being clean, dry and free of lubrication.

Footnotes below relate to tables 1-5

\* Ultimate load is 5 times the Working Load Limit. Individually proof tested to 2-1/2 times the Working Load Limit.

\*\* Ultimate load is 4 times the Working Load Limit. Individually proof tested to 2-1/2 times the Working Load Limit.

\*\*\* Individually proof tested to 2-1/2 times the Working Load Limit based on 4:1 design factor

\*\*\*\* Ultimate load is 5 times the Working Load Limit. Individually proof tested to 2 times the Working Load Limit.

†† Long bolts are designed to be used with soft metal (i.e., aluminum) workpiece. While the long bolts may also be used with ferrous metal (i.e., steel & iron) workpieces, short bolts are designed for ferrous workpieces only.

‡ Bolt specification is an Alloy socket head cap screw to ASTM A574. All threads are UNC.

‡‡ Bolt specification is a Grade 12.9 Alloy socket head cap screw to DIN 912. All threads are metric (ASME/ANSI B18.3.1m)

Δ Bolt specification is a Grade L7 or L43 Alloy socket head cap screw to ASTM A320. All threads are UNC.

††† Tighten bolt to specified torque, then tighten nut to specified torque.

All Swivel Hoist Rings are individually proof tested.

Table 7			
SS-125 ¥¥			
Working Load Limit (lbs.) ¥	Torque in Ft.-Lbs. †	Bolt Size (in.) §	Effective Thread Projection (in.)
400	3.5	5/16 - 18 x 1	.29
400	3.5	5/16 - 18 x 1.25	.54
500	6	3/8 - 16 x 1.25	.54
1250	14	1/2 - 13 x 2	.78
1250	14	1/2 - 13 x 2.25	1.03
1250	14	1/2 - 13 x 2.5	1.28
2000	30	5/8 - 11 x 2	.78
2000	30	5/8 - 11 x 2.25	1.03
2000	30	5/8 - 11 x 2.5	1.28
2500	50	3/4 - 10 x 2.25	1.03
2500	50	3/4 - 10 x 2.75	1.53
3500	50	3/4 - 10 x 2.75	1.04
3500	50	3/4 - 10 x 3.25	1.54
4000	80	7/8 - 9 x 2.75	1.04
4000	80	7/8 - 9 x 3	1.29
5000	115	1 - 8 x 3	1.29
5000	115	1 - 8 x 3.25	1.54
5000	115	1 - 8 x 4	2.29
7500	235	1-1/4 - 7 x 4	1.89
12000	400	1-1/2 - 6 x 5.5	2.70
15000	550	2 - 4-1/2 x 5.75	2.96
25000	1050	2-1/2 - 4 x 8	4.00
25000	1050	2-1/2 - 8 x 8	4.00
37500	2150	3 - 4 x 10.25	5.00
50000	2550	3-1/2 - 4 x 13	7.00

Table 8			
SS-125M ¥¥			
Working Load Limit (kg) ¥	Torque in (Nm) †	Bolt Size (mm) §§	Effective Thread Projection (mm)
200	4	M 8 x 1.25 x 30	13
250	8	M 10 x 1.50 x 35	18
525	18	M 12 x 1.75 x 50	19
950	40	M 16 x 2.00 x 60	29
1075	68	M 20 x 2.50 x 65	34
1500	68	M 20 x 2.50 x 75	32
2100	108	M 24 x 3.00 x 80	37
2100	108	M 30 x 3.50 x 110	58
3500	318	M 30 x 3.50 x 95	42
3500	318	M 30 x 3.50 x 115	62
5500	542	M 36 x 4.00 x 135	64
6250	542	M 42 x 4.50 x 155	82
6750	746	M 48 x 5.00 x 155	82
11150	1423	M 64 x 6.00 x 205	101
15750	2915	M 72 x 6.00 x 265	132
22300	3459	M 90 x 6.00 x 330	177

Footnotes below relate to Tables 6 and 7

¥ Ultimate load is 5 times the Working Load Limit. Individually proof tested to 2 times the Working Load Limit.

¥¥ All components are 316 Stainless Steel, except Bolt Retainers, which are made from 15-7 PH (UNS 15700) magnetic stainless steel.

§ Bolt specification is 316 Stainless Steel socket head cap screw to ASTM F 837 Group 1 (316).

§§ Bolt specification is 316 Stainless Steel socket head cap screw to ASTM F837M (316).

All threads are Metric (ASME/ANSI B18.3.1M).

# CROSBY® THIMBLE EYE BUNDLE CLIPS

## WARNING & APPLICATION INSTRUCTIONS

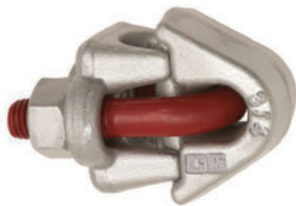

**G-461**

The Bundle Clip is utilized in a choker hitch application to maintain the shape of bundled packages after a load is placed. The Bundle Clip is attached to live line of choker hitch, but it is never to be used as a button or ferrule to carry a load in the primary load path.

Certain conditions (such as extreme variation of the choke size) or improper installation may cause the eye of the choke hitch to disengage from the Bundle Clip and allow the eye to seat away from or below the Bundle Clip (see Figure 3). If this occurs, the Bundle Clip must be removed and installed in the proper position.

The Bundle Clip is sized to provide a grip to the live rope without reducing the efficiency of a choker hitch. This grip is adequate to keep the bundle clip in position.

These instructions are for use with thimble eyes formed with RRL or RLL wire rope, 6 x 19 or 6 x 36 Class, FC or IWRC; IPS or XIP, XXIP, and a Crosby Thimble. For other classes of wire rope not mentioned above, we recommend contacting Crosby Engineering.

**For Soft Eye applications see the Crosby G-460 Soft Eye Bundle Clip.**

**For OSHA (Construction) applications, see OSHA 1926.251.**

1. The eye of the sling must be in the choked position (around live line). Choker hitch applications should comply with the requirements of ASME B30.9 Slings. Install the choker hitch to provide a minimum choke angle of 120 degrees (See Figure 1). Refer to ASME B30.9 for required de-rating of the sling if choke angle is less than 120 degrees.

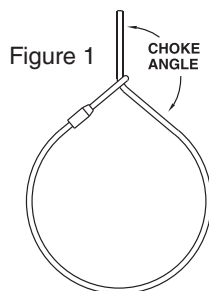

2. Before installing Bundle Clip, apply initial load by lifting the bundle and clearing the support, producing a tight choke. Repeat as necessary until the bundle package is in the most compact position (See figure 2, Loaded). **Keep hands and feet from under load.**

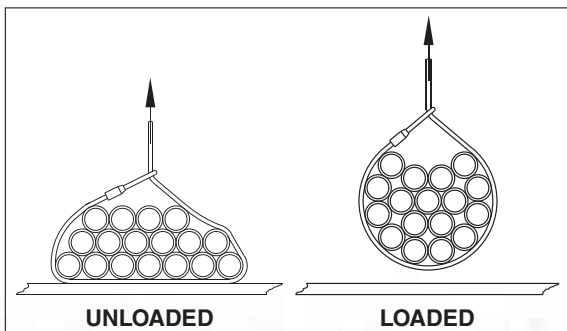

Figure 2

## WARNING

- Failure to read, understand, and follow these instructions may cause death or serious injury.
- A falling load may seriously injure or kill.
- Read and understand these instructions before using clips.
- Failure to properly position the Bundle Clip may allow the load to slip and fall.
- Match the same size clip to the same size wire rope.
- Install Bundle Clip only as instructed.
- Do not use with plastic coated wire rope.
- Do not use for lifting personnel.

3. After initial loading, install the Bundle Clip. The orientation of the Bundle Clip on the live line is not an important consideration, as the assembly is of adequate size to prevent passage through proper size Crosby Thimble and next larger size Thimble. Insert U-bolt through the Bundle Clip. Properly position the clip base over the U-bolt and install nuts (See Figure 3). Use torque wrench to tighten evenly, alternating from one nut to the other until the bundle stop bottoms out on the clip base, and the recommended torque is reached (See Table 1).

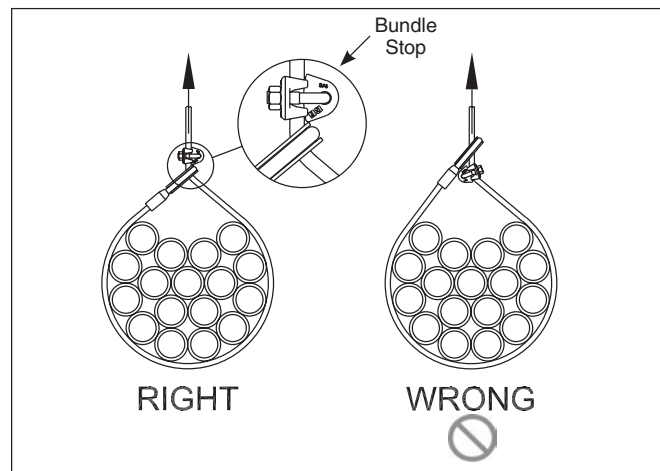

Figure 3

**Table 1 – Recommended Torque**

Clip Size	Rope Size (mm)	Torque (Nm)
5/8	16	129
3/4	19	176
7/8	22	305

4. Before each lift, check to ensure that the choke eye has not slipped from the Bundle Clip. Repeat Step 3 if necessary.
5. When disconnecting, the load should be clear of the stable support (See figure 2, Loaded). Remove Bundle Clip. Stay clear of the load as the bundle is lowered and the load is removed from the sling.

In accordance with good rigging and maintenance, the wire rope sling should be inspected periodically for wear, abuse, and general adequacy.

rev 1



# CROSBY® SOFT EYE BUNDLE CLIPS

## WARNING & APPLICATION INSTRUCTIONS

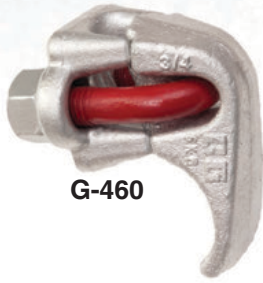

G-460

The Bundle Clip is utilized in a choker hitch application to maintain the shape of bundled packages after a load is placed. The Bundle Clip is attached to live line of choker hitch, but it is never to be used as a button or ferrule to carry a load in the primary load path.

Certain conditions (such as extreme variation of the choke size) or improper installation may cause the eye of the choke hitch to disengage from the Bundle Clip and allow the eye to seat away from or below the Bundle Clip (see Figure 3). If this occurs, the Bundle Clip must be removed and installed in the proper position.

The Bundle Clip is sized to provide a grip to the live rope without reducing the efficiency of a choker hitch. This grip is adequate to keep the bundle clip in position. The eye may pull free of the Bundle Clip if not positioned properly.

These instructions are for use with soft eyes (no thimble) formed with RRL or RLL wire rope, 6 x 19 or 6 x 36 Class, FC or IWRC; IPS or XIP, XXIP. For other classes of wire rope not mentioned above, we recommend contacting Crosby Engineering.

**For Thimble Eye applications see the Crosby G-461 Thimble Eye Bundle Clip.**

**For OSHA (Construction) applications, see OSHA 1926.251.**

1. The eye of the sling must be in the choked position (around live line). Choker hitch applications should comply with the requirements of ASME B30.9 Slings. Install the choker hitch to provide a minimum choke angle of 120 degrees (See Figure 1). Refer to ASME B30.9 for required de-rating of the sling if choke angle is less than 120 degrees.

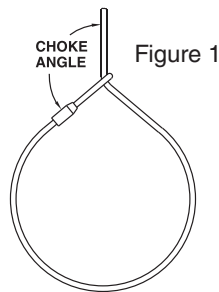

2. Before installing Bundle Clip, apply initial load by lifting the bundle and clearing the support, producing a tight choke. Repeat as necessary until the bundle package is in the most compact position (See figure 2, Loaded). **Keep hands and feet from under load.**

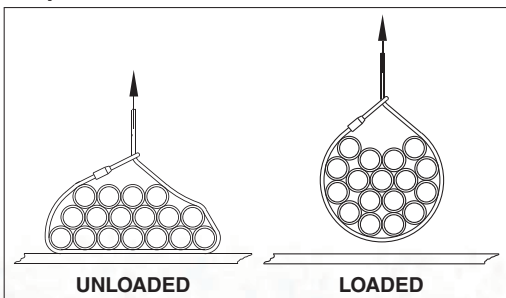

Figure 2

rev 1

### WARNING

- Failure to read, understand, and follow these instructions may cause death or serious injury.
- A falling load may seriously injure or kill.
- Read and understand these instructions before using clips.
- Failure to properly position the Bundle Clip may allow the load to slip and fall.
- Do not use the Bundle Clip to form the choke hitch (See Figure 3).
- Match the same size clip to the same size wire rope.
- Install Bundle Clip only as instructed.
- Do not use with plastic coated wire rope.
- Do not use for lifting personnel.

3. After initial loading, install the Bundle Clip in proper orientation, with curved portion (Bundle Clip tip) over the eye of the sling. Insert U-bolt through the Bundle Clip. Properly position the clip base over the U-bolt and install nuts (See Figure 3). Use torque wrench to tighten evenly, alternating from one nut to the other until the curved portion bottoms out on the clip base, and the recommended torque is reached (See Table 1).

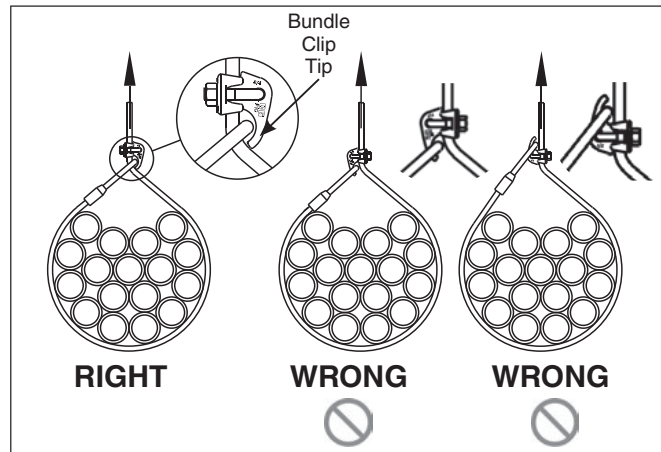

Figure 3

Clip Size	Rope Size (mm)	Torque (Nm)
5/8	16	129
3/4	19	176
7/8	22	305

4. Before each lift, check to ensure that the choke eye has not slipped from the Bundle Clip tip. Repeat Step 3 if necessary.
5. When disconnecting, the load should be clear of the stable support (See figure 2, Loaded). Remove Bundle Clip. Stay clear of the load as the bundle is lowered and the load is removed from the sling.

In accordance with good rigging and maintenance, the wire rope sling should be inspected periodically for wear, abuse, and general adequacy.

# CROSBY Slide-Loc® Lifting Point

## WARNINGS & APPLICATION INSTRUCTIONS



SL-150 & SL-150M  
Slide-Loc Lifting Point

### WARNING

- Load may slip or fall if proper Lifting Point assembly and lifting procedures are not used.
- A falling load can seriously injure or kill.
- Do not use with damaged slings or chain. For inspection criteria see ASME B30.9.
- Use only genuine Crosby bolts as replacements.
- Read and understand these warnings and application instructions.
- Do not load the Lifting Point if the slide lock is in the installation position (Red QUIC-CHECK mark is visible).

### LIFTING POINT

#### APPLICATION / ASSEMBLY INSTRUCTIONS

- Lifting Points incorporate a red indented area on each forged bail that provides a quick indicator to determine whether the Lifting Point is in the installation position or the lifting position. If the **QUIC-CHECK** mark (Figure 2) means the slide lock and bolt are engaged for installation. When Lifting Point is properly installed, move slide lock to lifting position (Figure 1).
- **To check**, look for indented surface (red) on bail. A visible **QUIC-CHECK** mark (Figure 2) means the slide lock and bolt are engaged for installation. When Lifting Point is properly installed, move slide lock to lifting position (Figure 1).
- Use Lifting Points only with a ferrous metal (i.e., steel, iron) or soft metal (e.g., aluminum) load (workpiece). Do not leave threaded end of Lifting Point in aluminum loads for long time periods due to corrosion.
- When using lifting slings of two or more legs, make sure the forces in the legs are calculated using the angle from the horizontal sling angle to the leg and select the proper size swivel hoist ring to allow for the angular forces.
- After determining the loads on each Lifting Point, select the proper size Lifting Point using the Working Load Limit ratings in Table 1 for UNC threads and Table 2 for Metric threads.
- Never exceed rated capacity of Lifting Point. See Table 1 for UNC threads, and Table 2 for metric threads.
- Drill and tap the workpiece to the correct size to a minimum depth of one-half the threaded shank diameter plus the threaded shank length.
- Install Lifting Point by hand so that the bushing flange is held tight to the mounting surface by the bolt. The bushing flange should engage the entire mounting surface.
- Never use spacers between bushing flange and mounting surface.
- Always select proper load rated lifting device for use with Lifting Points.
- Attach lifting device ensuring free fit to Lifting Point bail. (Figure 6)
- Never lift load if Red **QUIC-CHECK** indicator is visible. (Figure 2)
- Apply partial load and check proper rotation and alignment. The Lifting Point bail should be in-line with the direction of the load.

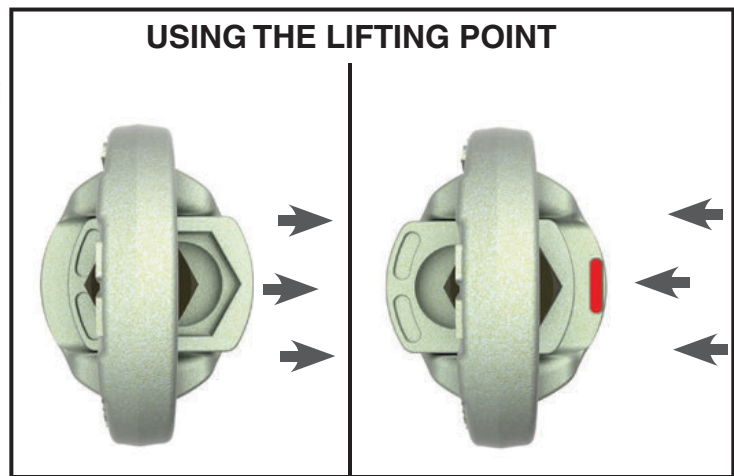

Figure 1

Figure 2

- Do not load in a direction perpendicular to the bail. (Figure 5)
- Special Note: When a Lifting Point is installed with a retention nut, the nut must have a full thread engagement and must meet one of the following standards to develop the Working Load Limit (WLL):

1. ASTM A-563
  - A. Grade D Hex Thick
  - B. Grade DH Standard Hex
2. SAE Grade 10.9 — Standard Hex

#### To place the Lifting Point:

- Move the slide lock into the installation position, such that the four flats on the bolt head are engaged. (Figure 2)
- Thread the bolt of the Lifting Point into the hole of your workpiece making sure that the entire length of exposed bolt thread is engaged. If the hole on your workpiece is not threaded, ensure that the Lifting Point is secured with a nut on the opposite side of your workpiece and that that nut thread is fully engaged.

- Before applying any load, ensure that the slide lock has been moved back into the lifting position and that the bail is free to rotate. (Figure 1)
- The Lifting Point can be loaded in any direction shown in Figure 4.
- Do not swivel the Lifting Point while supporting a load. The Lifting Point is a positioning device and is not intended to swivel under load.

### To remove Lifting Point

- Move the slide lock into the installation position, such that the four flats on the bolt head flats are engaged. (Figure 2)
- Unthread the Lifting Point from your workpiece.

### Lifting Point Inspection / Maintenance

- Perform regular daily inspections as recommended.
- Always inspect Lifting Point before use.
- Regularly inspect Lifting Point parts. (Figure 3)
- Never use Lifting Point that shows signs of corrosion, wear or damage.
- Never use Lifting Point if bail is bent or elongated.
- Always be sure threads on shank and receiving hole are clean, not damaged, and fit properly.
- Never use spacers (washers) between bushing flange and the mounting surface.
- Always ensure free movement of bail. The bail should swivel 360 degrees. (Figure 3)
- Always be sure total workpiece surface is in contact with Lifting Point bushing mating surface. Drilled and tapped hole must be 90 degrees to load (workpiece) surface.

Table 1		
Working Load Limit 4:1 (t)	UNC Bolt Size (in.)	Effective Thread Projection Length (in.)
.5	3/8	.61
.75	1/2	.80
1.50	5/8	1.01
2.30	3/4	1.28
2.30	7/8	1.63
3.20	1	1.93

Table 2		
Working Load Limit 4:1 (t)	Metric Bolt Size (mm)	Effective Thread Projection Length (mm)
.5	10	14.7
.75	12	18.1
1.50	16	24.5
2.30	20	31.0
3.20	24	37.0

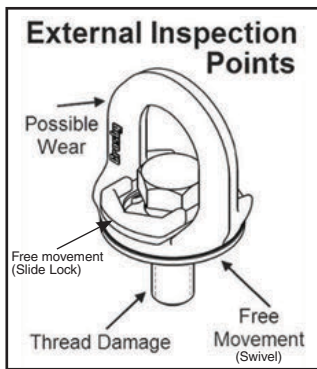

Figure 3

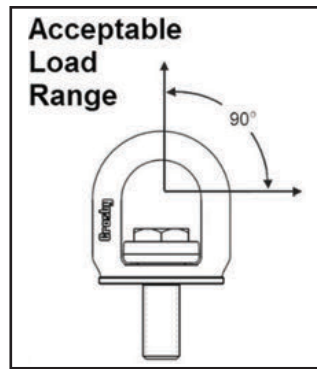

Figure 4

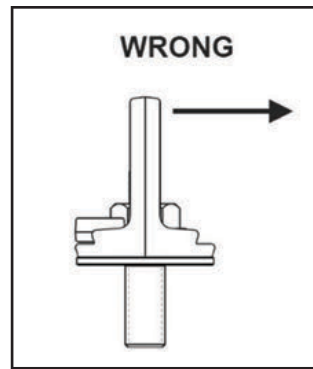

Figure 5

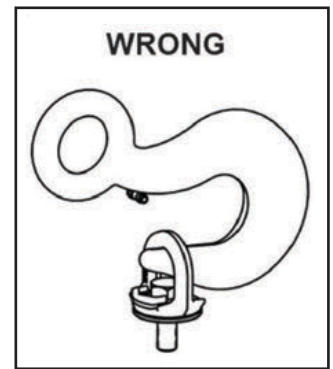
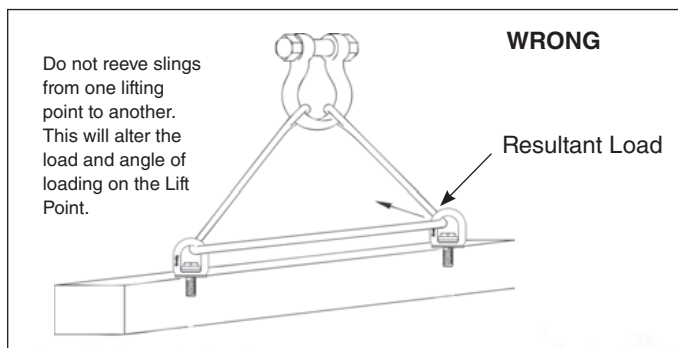
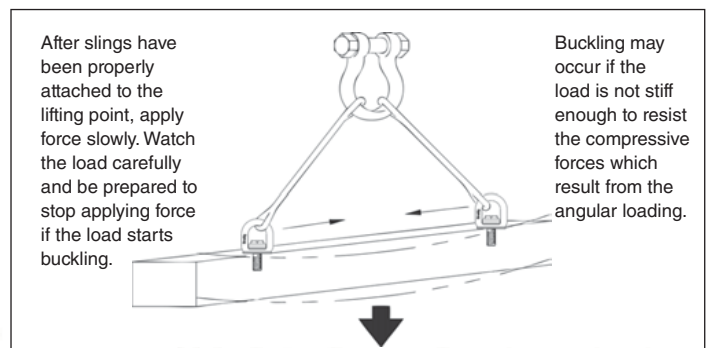

Figure 6



**WRONG**

Resultant Load



Buckling may occur if the load is not stiff enough to resist the compressive forces which result from the angular loading.





# CHAIN & ACCESSORIES

With Product Warning and Application Information



# CROSBY ELIMINATOR®

LOOK TO THE CROSBY PLATINUM LINE FOR PREMIUM SLING RIGGING



A-1361 shown with optional S-4104N Latch Pin.

A-1362 shown with optional S-4104N Latch Pin

## The Top ELIMINATOR Advantages Over The Competition

- RFID-equipped: No extra tag needed when using an electronic inspection system
- Crosby QUIC-CHECK® marks forged into the bail for quick and easy overload indication
- Optional S-4104N Latch Pin keeps the shortened chain in position when sling is removed from the crane hook temporarily
- Hinged design prevents bending when fitting is against a curved object
- The Crosby Eliminator® 2-piece design allows maximum flexibility; The same bail fits either the single or double hook
- Available in five sizes, 9/32" (7mm) through 5/8" (16mm)
- Wider and longer bail accommodates more hook sizes
- Only 2 fittings needed to build any adjustable sling, from single leg to quad
- Easy assembly of triple and quad chain slings
- Use the ELIMINATOR assembly with an oblong link to fit oversize hooks
- All Crosby ELIMINATOR® fittings are made in the U.S.A.

Crosby 8/10™ Fatigue Rated

QT  
QUENCHED & TEMPERED



QUIC-CHECK®



Crosby®



Scan this QR Code with your smart device to view the catalog page.



## GENERAL INFORMATION

### WORKING LOAD LIMIT

The "Working Load Limit" is the maximum load in pounds which should ever be applied to chain, when the chain is new or in as-new" condition, and when the load is uniformly applied in direct tension to a straight length of chain.

### PROOF TEST

The "Proof Test" is a term designating the tensile test applied to new chain for the sole purpose of detecting injurious defects in the material or manufacture. It is the load that the chain has withstood under a test in which the load has been applied in direct tension to a straight length of chain.

### MINIMUM ULTIMATE LOAD

The "Minimum Ultimate Load" is the minimum load at which new chain will break when tested by applying direct tension to a straight length of chain at a uniform rate of speed in a testing machine.

### ATTACHMENTS

Any attachments, such as hooks or links, should have a rated "Working Load Limit" at least equal to the chain with which it is used.

### SYMMETRICAL LOADING

Rated Working Load Limit assumes symmetrical loading of all sling legs.

### SPECIFICATIONS: ANSI B30.9 2006

Paragraph 9-1.6.1 "Prior to initial use, all new and repaired chain and components of an alloy steel chain sling, either individually or as an assembly, shall be proof tested by the sling manufacturer or qualified person."



## CAUTION

Only Crosby Alloy chain, Spectrum 8® or Spectrum 10®, should be used for overhead lifting applications.

**General Usage** – It must be recognized that certain factors in the usage of chain and attachments can be abusive and lessen the load that the chain or attachments can withstand. Some examples are twisting of the chain; disfigurement; deterioration by straining, usage, weathering and corrosion; rapid application of load or jerking; applying excessive loads; sharp corner cutting action and non-symmetrical loading effects.

When using chain slings in choker applications, the Working Load Limit must be reduced by 20% Crosby recommends a minimum angle of choke of 120 degrees. Consult Crosby when planning to use an angle of choke of less than 120 degrees. If Crosby A-1338 cradle grab hooks are used at a minimum angle of choke of 120 degrees, the full sling rated WLL can be utilized.



In shortening applications, a 20% reduction of the Working Load Limit is required except when using the Crosby A-1338 Cradle Grab Hooks, S-1311 Chain Shortener Link, the A-1355 Chain Choker Hook in conjunction with the S-1325 Chain Coupler Link, or the Crosby ELIMINATOR® shortener link. They can be used without any reduction to the Working Load Limit.

Care should be taken to observe these derated applications or chain may fracture or permanently stretch at loads less than the advertised chain ultimate strength and proof load respectively.

**Environmental Effects** – Excessive high or low temperatures, or exposure to chemically active environments such as acids or corrosive liquids or fumes, can reduce the performance of the chain.

### Temperature

- Extreme temperatures will reduce the performance of alloy steel chain slings.
- Normal operating temperature is -40° F to 400° F (-40° C to 204° C).

- See the temperature exposure chart (Table 1) to determine reduction of WLL due to operation at, and exposure to, elevated temperatures.

**Chemically Active Environments** can have detrimental effects on the performance of chain. The effects can be both visible loss of material and undetectable material degradation causing significant loss of strength.

- Usage Exposure – Exposure to chemically active environments such as acids or corrosive liquids or fumes can reduce the performance of the chain.
- Special Surface Coating/Plating/Galvanizing – Chain should not be subjected to galvanizing, or any plating process.
- If it is suspected that the chain has been exposed to chemically active environment, remove from service.

Temperature of Chain		Grade 8 (80) Chain		Grade 10 (100) Chain	
(F°)	(C°)	Temporary Reduction of Rated Load at Elevated Temperature*	Permanent Reduction of Rated Load After Exposure to Temperature**	Temporary Reduction of Rated Load at Elevated Temperature*	Permanent Reduction of Rated Load After Exposure to Temperature**
Below 400	Below 204	None	None	None	None
400	204	10%	None	15%	None
500	260	15%	None	25%	5%
600	316	20%	5%	30%	15%
700	371	30%	10%	40%	20%
800	427	40%	15%	50%	25%
900	482	50%	20%	60%	30%
1000	538	60%	25%	70%	35%
Over 1000	Over 538	OSHA 1910.184 and ASME B30.9 requires all slings exposed to temperatures over 1000° F to be removed from service.			

\* Crosby does not recommend the use of Alloy Chain at temperatures above 800° F.

\*\* When chain is used at room temperature after being heated to temperatures shown in the first column.



# Crosby® Grade 100 Chain Sling Configurations

## TO MAKE YOUR CROSBY® GRADE 100 ALLOY CHAIN SLING

Follow these simple steps in making a sling assembly:

1. Determine the maximum load to be lifted by the sling assembly.
2. Choose the type of sling assembly suited for the shape of the load and the size of the sling assembly for the load to be lifted. The decision must take into account the angle of the sling legs in multileg slings.
3. Determine the overall reach from bearing point of master link to bearing point on hook (see Fig. 1).
4. Select components, assemble chain and components.
5. Affix sling identification tag to sling. The tag is available from your Authorized Crosby Distributor.



Fig. 1

Each sling shall be marked to show: name or trademark of manufacturer, grade, nominal chain size, number of legs, rated load for the type(s) of hitch(es) used and angle upon which it is based (reach).

If measurement comes in the link, cut the following link. For two leg type slings, count the links and use an even number for clevis

hooks and an odd number for eye hooks. This will position hooks in the same plane. In multileg slings always use the same number of links in each leg.

When using chain slings in choker applications, the Working Load Limit must be reduced by 20%. Crosby recommends a minimum angle of choke of 120 degrees. Consult Crosby when planning to use an angle of choke of less than 120 degrees. If Crosby A-1338 cradle grab hooks are used at a minimum angle of choke of 120 degrees, the full sling rated WLL can be utilized.



In shortening applications, a 20% reduction of the Working Load Limit is required except when using the Crosby A-1338 Cradle Grab Hooks, S-1311 Chain Shortener Link, the A-1355 Chain Choker Hook in conjunction with the S-1325 Chain Coupler Link, or the Crosby ELIMINATOR® shortener link. They can be used without any reduction to the Working Load Limit.



The Slings shown here are standard assemblies that can be made from "Proof Tested" Crosby Components and Alloy Chain supplied by your authorized Crosby distributor. Assemblies must include chain sling identification tag (not shown, see page 238).



TYPE CO    TYPE SOS    TYPE SOG    TYPE SOF    TYPE SSS    TYPE SGS    TYPE ASOS    TYPE ASOF    TYPE ASOG    TYPE SOCH

Type	Description	Type	Description
CO	Single Chain Sling with Master Link each end	SGS	Single Chain Sling with Grab Hook and Sling Hook
SOS	Single Chain Sling with Master Link and Sling Hook	ASOS	Adjustable Single Chain with Master Link and Sling Hook
SOG	Single Chain Sling with Master Link and Grab Hook	ASOF	Adjustable Single Chain Sling with Master Link and Foundry Hook
SOF	Single Chain Sling with Master Link and Foundry Hook	ASOG	Adjustable Single Chain Sling with Master Link and Grab Hook
SSS	Single Chain Sling with Sling Hook each end	SOCH	Single with 1355 Choker



TYPE DOS    TYPE DOG    TYPE DOF    TYPE ADOS    TYPE ADOG    TYPE DOCH

Type	Description	Type	Description
DOS	Double Chain Sling with Master Link and Sling Hook	ADOS	Adjustable Double Chain Sling with Master Link and Sling Hook
DOG	Double Chain Sling with Master Link and Grab Hook	ADOG	Adjustable Double Chain Sling with Master Link and Grab Hook
DOF	Double Chain Sling with Master Link and Foundry Hook	DOCH	Double with 1355 Choker



TYPE TOS    TYPE TOG    TYPE TOF    TYPE TOCH    TYPE QOS    TYPE QOG    TYPE QOF

Type	Description	Type	Description
TOS	Triple Chain Sling with Master Link and Sling Hook	QOS	Quadruple Chain Sling with Master Link and Sling Hook
TOG	Triple Chain Sling with Master Link and Grab Hook	QOG	Quadruple Chain Sling with Master Link and Grab Hook
TOF	Triple Chain Sling with Master Link and Foundry Hook	QOF	Quadruple Chain Sling with Master Link and Foundry Hook
TOCH	Triple with 1355 Choker		

# Crosby® ELIMINATOR

## TO ORDER YOUR CROSBY ELIMINATOR® GRADE 100 ALLOY CHAIN SLING

Follow these simple steps to order a sling assembly:

1. Determine the maximum load to be lifted by the sling assembly.
2. Choose the type of sling assembly suited for the shape of the load and the size of the sling assembly for the load to be lifted. The decision must take into account the angle of the sling legs in multileg slings.
3. Determine the overall reach from bearing point of Eliminator Bail to bearing point on hook (see Fig. 1).
4. Select components, assemble chain and components.
5. Affix sling identification tag to sling. The tag is available from your Authorized Crosby Distributor.



Fig. 1

When using chain slings in choker applications, the Working Load Limit must be reduced by 20%. Crosby recommends a minimum angle of choke of 120 degrees. Consult Crosby when planning to use an angle of choke of less than 120 degrees. If Crosby A-1338 cradle grab hooks are used at a minimum angle of choke of 120 degrees, the full sling rated WLL can be utilized.



In shortening applications, a 20% reduction of the Working Load Limit is required except when using the Crosby A-1338 Cradle Grab Hooks, S-1311 Chain Shortener Link, the A-1355 Chain Choker Hook in conjunction with the S-1325 Chain Coupler Link, or the Crosby ELIMINATOR® shortener link. They can be used without any reduction to the Working Load Limit.

Each sling shall be marked to show: name or trademark of manufacturer, grade, nominal chain size, number of legs, rated load for the type(s) of hitch(es) used and angle upon which it is based (reach).



TYPE ESOS



TYPE ESOG



TYPE ESOL



TYPE ESOF

Type	Description	Type	Description
ESOS	Crosby ELIMINATOR® Single Chain Sling with Sling Hook	ESOL	Crosby ELIMINATOR® Single Chain with SHUR-LOC® Hook
ESOG	Crosby ELIMINATOR® Single Chain Sling with Grab Hook	ESOF	Crosby ELIMINATOR® Single Chain with Foundry Hook



TYPE EDOS



TYPE EDQG



TYPE EDOL



TYPE EDQF

Type	Description	Type	Description
EDOS	Crosby ELIMINATOR® Double Chain Sling with Sling Hooks	EDOL	Crosby ELIMINATOR® Double Chain with SHUR-LOC® Hooks
EDQG	Crosby ELIMINATOR® Double Chain Sling with Grab Hooks	EDQF	Crosby ELIMINATOR® Double Chain with Foundry Hooks



TYPE ETOS



TYPE ETQG



TYPE ETOL



TYPE ETQF



TYPE EQOS



TYPE EQQG



TYPE EQOL



TYPE EQQF

Type	Description	Type	Description
ETOS	Crosby ELIMINATOR® Triple Chain Sling with Master Link and Sling Hooks	EQOS	Crosby ELIMINATOR® Quad Chain Sling with Master Link and Sling Hooks
ETQG	Crosby ELIMINATOR® Triple Chain Sling with Master Link and Grab Hooks	EQQG	Crosby ELIMINATOR® Quad Chain Sling with Master Link and Grab Hooks
ETOL	Crosby ELIMINATOR® Triple Chain Sling with Master Link and SHUR-LOC® Hooks	EQOL	Crosby ELIMINATOR® Quad Chain Sling with Master Link and SHUR-LOC® Hooks
ETQF	Crosby ELIMINATOR® Triple Chain Sling with Master Link and Foundry Hooks	EQQF	Crosby ELIMINATOR® Quad Chain Sling with Master Link and Foundry Hooks

## SINGLE LEG SLING

Spectrum 10 <sup>®</sup> Chain Size											
(mm)	(in.)	Grade 100 Chain Stock No.	Master Link A-1343 Stock No.	Master Link Assembly A-1346 Stock No.	ELIMINATOR L-1361 Stock No.	LOK-A-LOY <sup>®</sup> A-1337 Stock No.	Chain Coupler S-1325A Stock No.	Chain Shortener Link S-1311N Stock No.	SHUR-LOC <sup>®</sup> Clevis Hook S-1317 Stock No.	SHUR-LOC <sup>®</sup> Eye Hook S-1316 Stock No.	SHUR-LOC <sup>®</sup> Swivel Hook S-1326 Stock No.
7	1/4 (9/32)	1210055	1247076	—	1049802	1015104	1098500	1017869	1029000	1022914	1004313
8	5/16	1210076	1247076	—	1049809	1015113	1098504	1017878	1029009	1022914	1004313
10	3/8	1210097	1247087	—	1049818	1015122	1098508	1017897	1029018	1022923	1004322
13	1/2	1210118	1247096	—	1049827	1015136	1098512	1017906	1029027	1022932	1004331
16	5/8	1210139	1247124	—	1049836	1015145	1098516	1017915	1029036	1022941	1004340
18	3/4	1210160	1247133	—	—	1015154	—	—	1029071	1022942	1004349
20	3/4	1210160	1247142	—	—	1015154	—	—	1021071	1022942	1004349
22-23	7/8	1210202	1247151	—	—	1015163	—	—	1029080	1022943	1004358
26	1	1210223	1247160	—	—	1015172	—	—	1029089	1022944	—
32	1-1/4	—	1247165	—	—	1015181	—	—	—	—	—

## DOUBLE LEG SLING

Spectrum 10 <sup>®</sup> Chain Size		Grade 100 Chain Stock No.	Master Link A-1343 Stock No.	Master Link Assembly A-1346 Stock No.	ELIMINATOR L-1362 Stock No.	LOK-A-LOY <sup>®</sup> A-1337 Stock No.	Chain Coupler S-1325A Stock No.	Chain Shortener Link S-1311N Stock No.	SHUR-LOC <sup>®</sup> Clevis Hook S-1317 Stock No.	SHUR-LOC <sup>®</sup> Eye Hook S-1316 Stock No.	SHUR-LOC <sup>®</sup> Swivel Hook S-1326 Stock No.
(mm)	(in.)	Grade 100 Chain Stock No.	Master Link A-1343 Stock No.	Master Link Assembly A-1346 Stock No.	ELIMINATOR L-1362 Stock No.	LOK-A-LOY <sup>®</sup> A-1337 Stock No.	Chain Coupler S-1325A Stock No.	Chain Shortener Link S-1311N Stock No.	SHUR-LOC <sup>®</sup> Clevis Hook S-1317 Stock No.	SHUR-LOC <sup>®</sup> Eye Hook S-1316 Stock No.	SHUR-LOC <sup>®</sup> Swivel Hook S-1326 Stock No.
7	1/4 (9/32)	1210055	1247087	—	1049913	1015104	1098500	1017869	1029000	1022914	1004313
8	5/16	1210076	1247087	—	1049922	1015113	1098504	1017878	1029009	1022914	1004313
10	3/8	1210097	1247096	—	1049931	1015122	1098508	1017897	1029018	1022923	1004322
13	1/2	1210118	1247124	—	1049940	1015136	1098512	1017906	1029027	1022932	1004331
16	5/8	1210139	1247142	—	1049949	1015145	1098516	1017915	1029036	1022941	1004340
18	3/4	1210160	1247151	—	—	1015154	—	—	1029071	1022942	1004349
20	3/4	1210160	1247151	—	—	1015154	—	—	1021071	1022942	1004349
22-23	7/8	1210202	1247160	—	—	1015163	—	—	1029080	1022943	1004358
26	1	1210223	1247165	—	—	1015172	—	—	1029089	1022944	—
32	1-1/4	—	1247172	—	—	1015181	—	—	—	—	—

## TRIPLE AND QUAD LEG SLINGS

Spectrum 10 <sup>®</sup> Chain Size		Grade 100 Chain Stock No.	Master Link A-1343 Stock No.	Master Link Assembly A-1346 Stock No.	ELIMINATOR L-1361 Stock No.	LOK-A-LOY <sup>®</sup> A-1337 Stock No.	Chain Coupler S-1325A Stock No.	Chain Shortener Link S-1311N Stock No.	SHUR-LOC <sup>®</sup> Clevis Hook S-1317 Stock No.	SHUR-LOC <sup>®</sup> Eye Hook S-1316 Stock No.	SHUR-LOC <sup>®</sup> Swivel Hook S-1326 Stock No.	
(mm)	(in.)	Grade 100 Chain Stock No.	Master Link A-1343 Stock No.	Master Link Assembly A-1346 Stock No.	ELIMINATOR L-1361 Stock No.	LOK-A-LOY <sup>®</sup> A-1337 Stock No.	Chain Coupler S-1325A Stock No.	Chain Shortener Link S-1311N Stock No.	SHUR-LOC <sup>®</sup> Clevis Hook S-1317 Stock No.	SHUR-LOC <sup>®</sup> Eye Hook S-1316 Stock No.	SHUR-LOC <sup>®</sup> Swivel Hook S-1326 Stock No.	
7	1/4 (9/32)	1210055	—	1256874	See Page 225	1015104	1098500	1017869	1029000	1022914	1004313	
8	5/16	1210076	—	1256883		1015113	1098504	1017878	1029009	1022914	1022914	1004313
10	3/8	1210097	—	1256892		1015122	1098508	1017897	1029018	1022923	1022923	1004322
13	1/2	1210118	—	1256926		1015136	1098512	1017906	1029027	1022932	1022932	1004331
16	5/8	1210139	—	1256935		1015145	1098516	1017915	1029036	1022941	1022941	1004340
18	3/4	1210160	—	1256944		1015154	—	—	1029071	1022942	1022942	1004349
20	3/4	1210160	—	1256953		1015154	—	—	1021071	1022942	1022942	1004349
22-23	7/8	1210202	—	1256962		1015163	—	—	1029080	1022943	1022943	1004358
26	1	1210223	—	1256971		1015172	—	—	1029089	1022944	1022944	—
32	1-1/4	—	—	1014864*		1015181	—	—	—	—	—	—

\*A-1345





## SINGLE LEG SLING

Spectrum 10 <sup>®</sup> Chain Size											
(mm)	(in.)	SHUR-LOC <sup>®</sup> Swivel Hook w/ Bearing S-13326 Stock No.	Clevis Sling Hook L-1339 Stock No.	Eye Sling Hook L-1327 Stock No.	Cradle Grab Hook A-1338* Stock No.	Clevis Grab Hook A-1358* Stock No.	Clevis Grab Hook A-1348 Stock No.	Eye Grab Hook A-1328 Stock No.	Clevis Foundry Hook A-1359 Stock No.	Eye Foundry Hook A-1329 Stock No.	Chain Choker A-1355 Stock No.
7	1/4 (9/32)	1004413	1049112	1025869	1049417	1049610	1026200	1026169	1049907	1026280	1015204
8	5/16	1004413	1049121	1025869	1049426	1049629	1026200	1026169	1049911	1026280	1015204
10	3/8	1004422	1049130	1025878	1049435	1049638	1026209	1026187	1049916	1026289	1015213
13	1/2	1004431	1049149	1025887	1049444	1049647	1026218	1026196	1049925	1026297	1015222
16	5/8	1004440	1049158	1025896	1049453	1049656	1026227	1026205	1049934	1026306	1015231
18	3/4	—	1049167	1025915	—	—	—	1026214	1049943	1026315	—
20	3/4	—	1049167	1025915	—	—	—	1026214	1049943	1026315	—
22-23	7/8	—	1049176	1025924	—	—	—	1026223	1049952	1026324	—
26	1	—	—	1025933	—	—	—	1016232	—	—	—
32	1-1/4	—	—	1025942	—	—	—	1026241	—	—	—

## DOUBLE LEG SLING





Spectrum 10 <sup>®</sup> Chain Size		SHUR-LOC <sup>®</sup> Swivel Hook w/ Bearing S-13326 Stock No.	Clevis Sling Hook A-1339 Stock No.	Eye Sling Hook L-1327 Stock No.	Cradle Grab Hook A-1338* Stock No.	Clevis Grab Hook A-1358* Stock No.	Clevis Grab Hook A-1348 Stock No.	Eye Grab Hook A-1328 Stock No.	Clevis Foundry Hook A-1359 Stock No.	Eye Foundry Hook A-1329 Stock No.	Chain Choker A-1355 Stock No.
(mm)	(in.)										
7	1/4 (9/32)	1004413	1049112	1025869	1049417	1049610	1026200	1026169	1049907	1026280	1015204
8	5/16	1004413	1049121	1025869	1049426	1049629	1026200	1026169	1049911	1026280	1015204
10	3/8	1004422	1049130	1025878	1049435	1049638	1026209	1026187	1049916	1026289	1015213
13	1/2	1004431	1049149	1025887	1049444	1049647	1026218	1026196	1049925	1026297	1015222
16	5/8	1004440	1049158	1025896	1049453	1049656	1026227	1026205	1049934	1026306	1015231
18	3/4	—	1049167	1025915	—	—	—	1026214	1049943	1026315	—
20	3/4	—	1049167	1025915	—	—	—	1026214	1049943	1026315	—
22-23	7/8	—	1049176	1025924	—	—	—	1026223	1049952	1026324	—
26	1	—	—	1025933	—	—	—	1016232	—	—	—
32	1-1/4	—	—	1025942	—	—	—	1026241	—	—	—

## TRIPLE AND QUAD LEG SLINGS

Spectrum 10 <sup>®</sup> Chain Size		SHUR-LOC <sup>®</sup> Swivel Hook w/ Bearing S-13326 Stock No.	Clevis Sling Hook L-1339 Stock No.	Eye Sling Hook L-1327 Stock No.	Cradle Grab Hook A-1338* Stock No.	Clevis Grab Hook A-1358* Stock No.	Clevis Grab Hook A-1348 Stock No.	Eye Grab Hook A-1328 Stock No.	Clevis Foundry Hook A-1359 Stock No.	Eye Foundry Hook A-1329 Stock No.	Chain Choker A-1355 Stock No.
(mm)	(in.)										
7	1/4 (9/32)	1004413	1049112	1025869	1049417	1049610	1026200	1026169	1049907	1026280	1015204
8	5/16	1004413	1049121	1025869	1049426	1049629	1026200	1026169	1049911	1026280	1015204
10	3/8	1004422	1049130	1025878	1049435	1049638	1026209	1026187	1049916	1026289	1015213
13	1/2	1004431	1049149	1025887	1049444	1049647	1026218	1026196	1049925	1026297	1015222
16	5/8	1004440	1049158	1025896	1049453	1049656	1026227	1026205	1049934	1026306	1015231
18	3/4	—	1049167	1025915	—	—	—	1026214	1049943	1026315	—
20	3/4	—	1049167	1025915	—	—	—	1026214	1049943	1026315	—
22-23	7/8	—	1049176	1025924	—	—	—	1026223	1049952	1026324	—
26	1	—	—	1025933	—	—	—	1016232	—	—	—
32	1-1/4	—	—	1025942	—	—	—	1026241	—	—	—

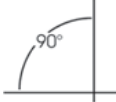
\* Available in latch version.

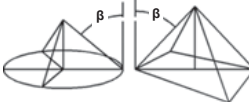
## WORKING LOAD LIMIT – 4 TO 1 DESIGN FACTOR

Nominal Size of Sling							
			Two Leg Slings		Triple and Four-Leg Slings		
(in.)	(mm)	Single Leg t	0° < β ≤ 45° t	45° < β ≤ 60° t	0° < β ≤ 45° t	45° < β ≤ 60° t	Choker Hitch *t
7/32	6	1,40	2,00	1,40	3,00	2,12	1,12
1/4 (9/32)	7	2,00	2,80	2,00	4,20	3,00	1,60
5/16	8	2,50	3,55	2,50	5,30	3,75	2,00
3/8	10	4,00	5,60	4,00	8,00	6,00	3,20
1/2	13	6,70	9,50	6,70	14,0	10,0	5,35
5/8	16	10,0	14,0	10,0	21,2	15,0	8,00
3/4	19	14,0	20,0	14,0	30,0	21,0	11,2
7/8	22	18,8	27,0	18,8	39,4	28,0	15,0
7/8	23	21,0	29,5	21,0	44,4	31,5	16,8
1	27	27,0	38,0	27,0	57,0	40,0	21,6
1-1/4	32	40,0	56,0	40,0	85,0	60,0	32,5

\*For choker applications, the Working Load Limit must be reduced by 20%. The Crosby A-1338 cradle grab hook and S1311N chain shorten link do not require any reduction of the Working Load Limit. The design factor of 4 to 1 on Spectrum® 10 Alloy Chain agrees with the design factor used by the International Standards Organization (I.S.O.) and ANSI B30.9 and is the preferred set of Working Load Limit values to be used.

# Crosby ELIMINATOR® Fittings



**A-1361**  
Single Hook

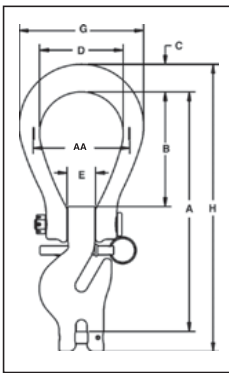

The Crosby ELIMINATOR® combines selected features and functionality of a master link, connecting link, grab hook and adjuster legs to provide you with one fitting that is suitable for applications that require an adjustable length chain sling.

- Forged Alloy Steel - Quenched and Tempered.
- Innovative two piece design allows for maximum flexibility.
- Individually Proof Tested with certification.
- The Crosby ELIMINATOR®, if properly installed and locked, can be used for personnel lifting applications and meets the intent of OSHA Rule 1926.1431(g)(1)(i)(A) and 1926.1501(g)(4)(iv)(B).
- Suitable for use with Grade 100 and Grade 80 chain.
- Engineered to accommodate optional locking pins that can be inserted to “lock” the shortened chain legs into place.
- Fatigue rated at 1-1/2 times the Working Load Limit at 20,000 cycles.
- Use the A-1361 and A-1362 in combination to make 3 leg chain slings.
- Load pin assembly instructions on page 276.
- “Look for the Platinum Color - Crosby Grade 100 Alloy Products.”
- All sizes are **RFID EQUIPPED**.



**A-1362**  
Single Hook

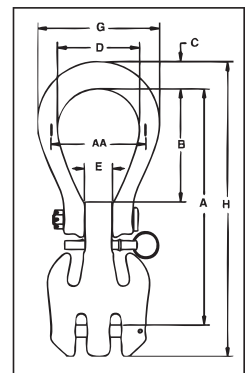

**Crosby 8/10™**



**Fatigue Rated®**



## A-1361 Crosby ELIMINATOR® Single Hook

Chain Size		Frame Size	Working Load Limit (t)*	A-1361 Stock No.	L-1361 Stock No.	Weight Each (kg)	Dimensions (mm)							
(in.)	(mm)						A	B	C	D	E	AA	G	H
1/4	7	2	2.0	1049797	1049802	1.76	208	99.0	22.9	76.2	23.9	89.0	112	248
5/16	8	2	2.6	1049804	1049809	1.76	208	99.0	22.9	76.2	23.9	89.0	112	248
3/8	10	3	4.0	1049813	1049818	2.94	255	122	29.5	88.9	28.7	102	132	306
1/2	13	4	6.8	1049822	1049827	6.12	327	152	41.4	105	33.3	127	162	395
5/8	16	5	10.3	1049831	1049836	10.9	388	175	49.8	121	41.4	152	188	472

\* Proof tested at 2.5 times the Working Load Limit. Minimum Ultimate Load is 4 times the Working Load Limit.

## A-1362 Crosby ELIMINATOR® Double Hook

Chain Size		Frame Size	Working Load Limit (t)*	A-1362 Stock No.	L-1362 Stock No.	Weight Each (kg)	Dimensions (mm)							
(in.)	(mm)						A	B	C	D	E	AA	G	H
1/4	7	2	3.9	1049859	1049913	2.13	208	99.0	22.9	76.2	23.9	89.0	112	257
5/16	8	2	5.0	1049868	1049922	2.13	208	99.0	22.9	76.2	23.9	89.0	112	257
3/8	10	3	8.0	1049877	1049931	3.67	255	122	29.5	88.9	28.7	102	132	319
1/2	13	4	13.6	1049886	1049940	7.84	327	152	41.4	105	33.3	127	162	413
5/8	16	5	20.5	1049895	1049949	14.3	388	175	49.8	121	41.4	152	188	491

\* Proof tested at 2 times the Working Load Limit. Minimum Ultimate Load is 4 times the Working Load Limit.

## Using Crosby ELIMINATOR® in 3 and 4 Leg Slings

See page 222-223 for basic chain sling components.

Spectrum 10® Chain Size		Master Link A-342 Stock No.	Master Link A-1342 Stock No.	Crosby ELIMINATOR® Single A-1361 Stock No.	Crosby ELIMINATOR® Double A-1362 Stock No.	Spectrum 10® Chain Size		Master Link A-342 Stock No.	Master Link A-1342 Stock No.	Crosby ELIMINATOR® Single A-1361 Stock No.	Crosby ELIMINATOR® Double A-1362 Stock No.
(in.)	(mm)					(in.)	(mm)				
1/4 (9/32)	7	1014285	1011412	1049797	1049859	1/4 (9/32)	7	1014285	1011412	—	1049859
5/16	8	1014319	1011421	1049804	1049868	5/16	8	1014319	1011421	—	1049868
3/8	10	1014331	1011430	1049813	1049877	3/8	10	1014331	1011430	—	1049877
1/2	13	1014348	1011449	1049822	1049886	1/2	13	1014348	1011449	—	1049886
5/8	16	1014365	1011458	1049831	1049895	5/8	16	1014365	1011458	—	1049895

Use one of either A-342 or A-1342 master link.  
Use one of each when making three leg sling.

Use one of either A-342 or A-1342 master link.  
Use two A-1362 fittings when making quad leg sling.





**A-1360B**  
Bail

**A-1360B Bail**

Chain Size		Frame Size	A-1360B Stock No.	Weight Each (kg)	S-4103 Replacement Hinge Pin Kit Stock No.
(in.)	(mm)				
1/4 - 5/16	7 - 8	2	1049626	.95	1092916
3/8	10	3	1049635	1.67	1092925
1/2	13	4	1049644	3.35	1092934
5/8	16	5	1049653	5.89	1092943



**A-1360S**  
Single Hook

**A-1360S Single Hook** (Shown with optional S-4104 Latch Pin)

Chain Size		Frame Size	Working Load Limit (t)*	A-1360S Stock No.	L-1360S Stock No.	Weight Each (kg)	S-4100 Replacement Load Pin Kit Stock No.
(in.)	(mm)						
1/4	7	2	2	1049671	1049790	.81	1091801
5/16	8	2	2.5	1049680	1049799	.81	1091810
3/8	10	3	4.0	1049699	1049808	1.27	1091829
1/2	13	4	6.7	1049706	1049817	2.76	1091838
5/8	16	5	10.0	1049715	1049826	5.03	1091847

\* Ultimate Load is 4 times the Working Load Limit.



**A-1360D**  
Double Hook

**A-1360D Double Hook** (Shown with optional S-4104 Latch Pin)

Chain Size		Frame Size	Working Load Limit (t)*	A-1360D Stock No.	L-1360D Stock No.	Weight Each (kg)	S-4102 Replacement Load Pin Kit Stock No.
(in.)	(mm)						
1/4	7	2	3.9	1049733	1049838	1.17	1092713
5/16	8	2	5.0	1049742	1049847	1.17	1092722
3/8	10	3	8.0	1049751	1049856	1.99	1092731
1/2	13	4	13.6	1049760	1049865	4.49	1092740
5/8	16	5	20.5	1049779	1049874	8.39	1092759

\* Ultimate Load is 4 times the Working Load Limit.

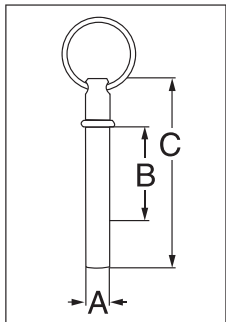

**S-4104N**  
Latch Pin

**S-4104N Latch Pin** • The new style S-4104N latch pin is colored yellow zinc. • The old style S-4104 latch pin is colored silver zinc.

Chain Size		Frame Size	S-4104N Stock No.	Weight Each (kg)	Dimensions (mm)		
(in.)	(mm)				A	B	C
1/4 - 5/16	7 - 8	2	1092983	.06	7.95	34.5	65.5
3/8	10	3	1092992	.06	7.95	38.6	78.2
1/2	13	4	1093001	.06	7.95	46.5	97.3
5/8	16	5	1093010	.06	7.95	56.1	117



## Grade 100 Alloy Chain



**Spectrum 10®**  
Grade 100  
Alloy Chain

- Alloy Steel.
- Heat Treated.
- 25% stronger than Grade 80 Alloy Chain.
- Permanently embossed with CG (Crosby Group) and 10 (Grade).
- Finish - Black rust preventative coating.
- Proof Tested at 2 times the Working Load Limit with certification.
- Standard container - fiber drum.

### Grade 100 Alloy Chain Recommended for overhead lifting applications

Chain Size		Gr. 100 Stock No.	Meters Per Drum	Dimensions (mm)	Working Load Limit (t)*	Weight Per Meter (kg)
(in.)	(mm)					
9/32 (1/4)	7	1210055	200	7 x 21	2.0	1.05
5/16	8	1210076	200	8 x 24	2.5	1.25
3/8	10	1210097	200	10 x 30	4.0	2.20
1/2	13	1210118	150	13 x 39	6.7	3.80
5/8	16	1210139	100	16 x 48	10.0	5.70
3/4	19	1210160	50	19 x 57	14.0	8.03
7/8	22	273867	50	23 x 69	21.0	10.9
7/8	23	1210202	50	23 x 69	21.0	10.9
1	26	1210232	50	26 x 78	26.5	15.2
1-1/4	32	1210250	20	32 x 96	40.0	23.0

\* Proof tested at 2 times Working Load Limit. Ultimate Load is 4 times the Working Load Limit.



**A-1337**  
10 Alloy  
Connecting Link

- Suitable for use with both Grade 80 and Grade 100 chain.
- Individually Proof Tested at 2-1/2 times Working Load Limit with certification.
- Locking system that provides for simple assembly and disassembly - no special tools needed.
- 25% stronger than Grade 80.
- Meets ASTM A-952-02 standards for Grade 100 chain fittings.
- Forged Alloy Steel - Quenched and Tempered.
- Sizes 9/32 through 1 inch are fatigue rated.
- "Look for the Platinum Color - Crosby Grade 100 Alloy Products."

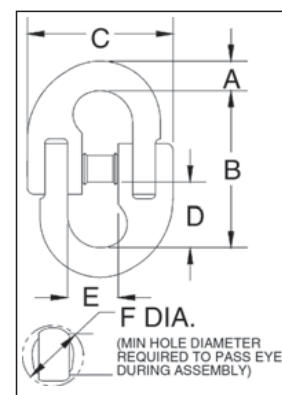

**Crosby 8/10™**



**Fatigue Rated®**

### LOK-A-LOY® 10 Alloy Connecting Link

Chain Size		A-1337 Stock No.	Pkg. Qty.	Weight Each (kg)	Working Load Limit (t)*	Dimensions (mm)					
(in.)	(mm)					A	B	C	D	E	F
9/32 (1/4)	7	1015104	60	.12	2.0	9.7	49.3	48.3	20.6	17.5	14.5
5/16	8	1015113	50	.16	2.5	9.40	59.7	52.6	25.1	18.3	16.3
3/8	10	1015122	40	.34	4.0	12.2	68.6	62.7	28.4	22.9	19.8
1/2	13	1015136	12	.73	6.8	17.3	87.6	84.1	36.6	28.4	24.6
5/8	16	1015145	10	1.30	10.3	20.6	105	99.1	43.7	34.3	29.0
3/4	20	1015154	1	2.26	16.0	23.6	118	118	53.1	40.4	32.5
7/8	22	1015163	1	3.41	19.4	26.9	140	143	58.7	50.0	36.6
1	25	1015172	1	5.00	27.1	31.0	152	157	63.5	56.4	47.8
1-1/4	32	1015181	1	9.25	41.0	38.1	189	194	78.5	64.3	55.6

\*Ultimate Load is 4 times the Working Load Limit. For Grade 6 LOK-A-LOY®, see page 252.

## Grade 100 Alloy Master Links



**A-1370**  
Reeving Link

- Alloy Steel - Quenched and Tempered.
- Individually proof tested to 2.5 times the Working Load Limit.
- Proof test certification shipped with each link.
- Each link has a Product Identification Code (PIC) for material traceability, along with the size and the name Crosby in raised letters.
- Suitable for use with Grade 100 and Grade 80 chain.
- "Look for the Platinum Color - Crosby Grade 100 Alloy Products."

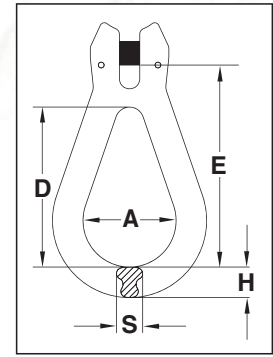

### A-1370 Reeving Link

Chain Size		Working Load Limit (t)	A-1370 Stock No.	Weight Each (kg)	Dimensions (mm)				
(in.)	(mm)				A	D	E	H	S
1/4-5/16	7-8	2.5	1012000	.26	39.0	67.5	90.0	16.0	10.0
3/8	10	4.0	1012009	.50	49.0	85.5	108	17.0	14.0
1/2	13	6.8	1012018	1.10	62.5	108	138	21.0	18.0
5/8	16	10.3	1012027	2.55	79.0	139	180	30.5	25.5



**A-1348**  
Eye Cradle Grab Hook

- Alloy Steel - Quenched and Tempered.
- Forged Alloy Steel - Quenched and Tempered.
- Innovative cradle design allows for 100% efficiency of Grade 100 chain.
- Individually Proof Tested to 2-1/2 times the Working Load Limit with certification.
- Each hook has a Product Identification Code (PIC) for material traceability, along with the size and the name Crosby in raised letters.
- Suitable for use with Grade 100 and Grade 80 chain.
- The use of A-1348 Cradle Grab Hook will allow 100% percent of the chain sling capacity. When used to hook back to chain leg to form a choker, the angle of the choke must be 120 degrees or greater. When used as a chain shortener, minimize twist of chain and ensure chain is fully engaged in hook.
- Fatigue rated at 1-1/2 times the Working Load Limit at 20,000 cycles.
- "Look for the Platinum Color - Crosby Grade 100 Alloy Products."

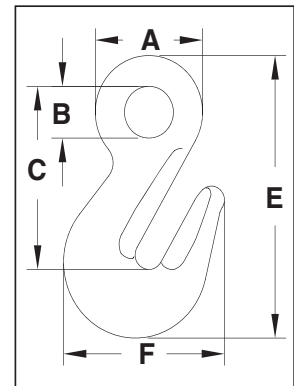

### A-1348 Eye Cradle Grab Hook

Chain Size		Working Load Limit (t)*	A-1348 Stock No.	Weight Each (kg)	Dimensions (mm)				
(in.)	(mm)				A	B	C	E	F
1/4-5/16	7-8	2.5	1026200	.35	36.3	16.5	64.0	98.2	58.2
3/8	10	4.0	1026209	.64	49.5	26.0	78.0	120	68.8
1/2	13	6.8	1026218	1.70	71.4	33.0	115	175	101
5/8	16	10.3	1026227	2.90	78.9	38.0	133	204	125

\* Minimum Ultimate Load is 4 times the Working Load Limit based on single leg sling.



# Grade 100 Welded Master Links



**A-1343**  
Welded Master Link

- Ratings below are for use with chain slings fabricated in accordance with ASTM B30.9.
- Alloy Steel - Quenched and Tempered.
- Design Factor of 4 to 1.
- Individually Proof Tested to values shown.
- Meets or exceeds all requirements of ASME B30.26 including identification, ductility, design factor, proof load and temperature requirements. Importantly, these master links meet other critical performance requirements including fatigue life, impact properties and material traceability, not addressed by ASME B30.26.
- Each link has a Product Identification Code (PIC) for material traceability, along with the size and "CG" stamped into it.



**A-1346**  
Welded Master Link Assembly

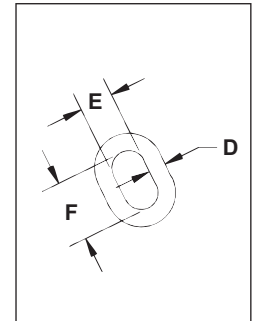
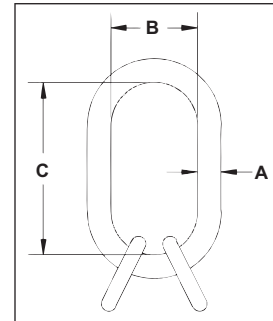
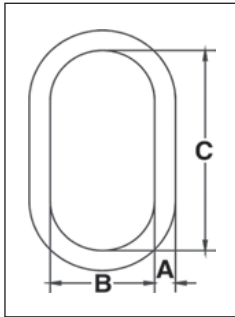

## A-1343 Welded Master Link

Size	A-1343 Stock No. S.C.	Weight Each (kg)	For use as Grade 100 Chain Sling		For use as Grade 80 Chain Sling		WLL (t)	Proof Load (t)	Dimensions (mm)		
			Single Leg Chain Size (mm)	Double Leg Chain Size (mm)	Single Leg Chain Size (mm)	Double Leg Chain Size (mm.)			A	B	C
12X1	1247069	0.30	6	—	6-7	6	1.6	4	12	60	120
13X2	1247076	0.36	7-8	6	8	7	2.5	6.3	13	60	120
17X3	1247087	0.86	10	7-8	10	8	4.1	10.3	17	90	160
19X4A	1247096	1.08	13	10	13	10	6.7	16.8	19	90	160
22X4B	1247115	1.59	13	10	16	13	8.5	21.3	22	90	170
25X5	1247124	2.43	16	13	18-19	16	11.5	28.8	25	115	210
28X6	1247133	3.91	16-18	13	18-20	16	13	32.5	28	145	275
31X7	1247142	4.86	19-20	16	22-23	18-20	17	42.5	31	145	275
36X8	1247151	6.87	22-23	18-20	26	22-23	24	60	36	155	285
38X9	1247160	7.63	26	22-23	32	26	31.5	78.8	38	140	270
50X10A	1247165	17.6	32	26	—	32	45	112.5	50	200	380
57X10B	1247172	24.5	—	32	—	—	65.3	163.3	57	203	406

See chart on page 206 for other sling angles.

## A-1346 Welded Master Link Assembly

Size	A-1346 Stock No.	Weight Each (kg)	For use as Grade 100 Chain Sling Three Four Legs Chain Size (mm)	For use as Grade 80 Chain Sling Three Four Legs Chain Size (mm)	WLL (t)	Proof Load (t)	Dimensions (mm)					
							A	B	C	D	E	F
17X1	1256868	1.58	6	7	4.1	10.3	17	90	160	13	60	120
19X2A	1256874	1.8	7	8	4.3	10.6	19	90	160	13	60	120
22X2B	1256883	3.35	8	10	6.7	16.8	22	100	180	17	90	160
25X3	1256892	5.51	10	10	8.9	22.3	25	146	275	19	90	160
28X4A	1256917	7.17	13	13	14.5	36.3	28	145	275	22	100	180
31X4B	1256926	9.72	13	16	17	42.5	31	145	275	25	115	210
36X5	1256935	12.2	16	18-19	23.6	59	36	146	275	28	100	190
40X6	1256944	18.68	18	19-20	28.1	70.3	40	160	300	31	145	275
45X7	1256953	26.56	19-20	22-23	38.3	95.8	45	180	340	36	155	285
50X8	1256962	32.86	22-23	26	45	112.5	50	200	380	38	140	370
57X9	1256971	59.7	26	32	67	167.5	57	203	406	50	200	380

\* A-1345. See chart on page 206 for other sling angles.

# Crosby® Grade 100 Eye Sling Hooks



**S-1327**  
Eye Sling Hook

- Forged Alloy Steel - Quenched and Tempered.
- Each hook has a Product Identification Code (PIC) for material traceability, along with the size and the name Crosby & U.S.A. in raised letters.
- 25% stronger than Grade 80.
- Eye Sling hooks incorporate two types of strategically placed markings forged into the product which address two (2) **QUIC-CHECK®** features: Deformation Indicators and Angle Indicators.
- Low profile hook tip.
- Utilizes S-4320 integrated latch which meets the world standard for lifting.
  - Heavy duty stamped latch interlocks with the hook tip.
  - High cycle, long life spring.
- When secured with the proper cotter pin through the hole in the tip of hook, meets the intent of OSHA Rule 1926.1431(g) and 1926.1501(g) for personnel lifting.
- Individually Proof Tested to 2-1/2 times the Working Load Limit with certification.
- Suitable for use with Grade 100 and Grade 80 chain.
- Fatigue rated at 1-1/2 times the Working Load Limit at 20,000 cycles.
- “Look for the Platinum Color - Crosby Grade 100 Alloy Products.”

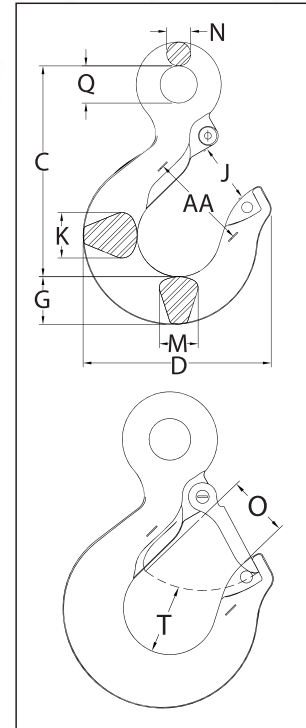

## S/L-1327 Eye Sling Hook

Grade 100 Alloy Chain Size		Working Load Limit (t)*	Hook ID Code	S-1327 Stock No.	L-1327 Stock No.	Weight Each (kg)	Dimensions (mm)										Replacement Latch Stock No.	
(in.)	(mm)						C	D	G	J	K	M	N	O	Q	T		AA
-	6	1.5	DA	1025857	1025860	.23	84.8	72.9	18.5	22.9	16.0	16.0	9.1	22.6	19.1	22.1	38.1	1096325
1/4-5/16	7 - 8	2.6	HA	1025866	1025869	.59	107	99.1	26.2	30.0	19.1	19.1	12.7	29.2	19.1	29.5	50.8	1096468
3/8	10	4.0	IA	1025875	1025878	1.04	127	110	30.2	38.9	30.2	25.4	14.2	35.6	23.9	31.2	63.5	1096515
1/2	13	6.8	JA	1025884	1025887	2.04	161	144	36.6	45.2	34.8	29.7	18.3	42.4	28.4	47.8	76.2	1096562
5/8	16	10.3	KA	1025893	1025896	3.81	189	172	47.8	60.5	42.2	36.6	22.4	56.1	33.3	51.6	102	1096609
3/4	18-20	16.0	KA	1025911	1025915	6.80	230	189	57.2	58.2	47.8	41.4	28.2	52.8	62.0	62.7	102	1096609
7/8	22-23	21.0	LA	1025920	1025924	9.39	256	211	65.8	63.5	55.6	49.3	32.3	57.7	72.1	66.5	102	1096657
1	26	27.1	NA	1025929	1025933	17.9	326	262	76.2	83.8	68.3	60.5	39.6	76.7	88.9	71.9	127	1096704
1 1/4	32	41.0	PA	1025938	1025942	47.6	462	357	116	108	95.3	81.0	50.8	76.2	114	98.6	178	1093717

\* Ultimate Load is 4 times the Working Load Limit.

# Crosby® Grade 100 Clevis Sling Hooks



**A-1339**  
Clevis Sling Hook

- Forged Alloy Steel - Quenched and Tempered.
- Individually Proof Tested to 2-1/2 times the Working Load Limit with certification.
- Each hook has a Product Identification Code (PIC) for material traceability, along with the size and the name Crosby & U.S.A. in raised letters.
- Hoist hooks incorporate two types of strategically placed markings forged into the product which address two (2) **QUIC-CHECK®** features: Deformation Indicators and Angle Indicators.
- Low profile hook tip.
- New integrated latch (S-4320/S-4339) meets the world standard for lifting.
  - Heavy duty stamped latch interlocks with the hook tip.
  - High cycle, long life spring.
  - When secured with the proper cotter pin through the hole in the tip of hook, meets the intent of OSHA Rule 1926.1431(g) and 1926.1501(g) for personnel lifting.
- Suitable for use with Grade 100 and Grade 80 chain.
- Fatigue rated at 1-1/2 times the Working Load Limit at 20,000 cycles.
- "Look for the Platinum Color - Crosby Grade 100 Alloy Products."

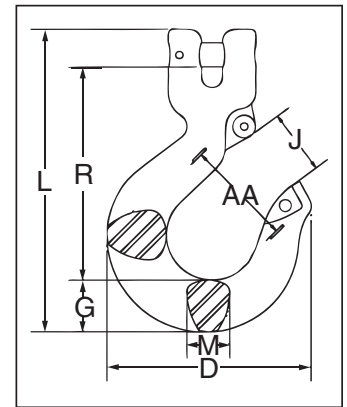

**Crosby 8/10™**



**Fatigue Rated®**



## A/L-1339 Clevis Sling Hook

Chain Size		Working Load Limit (t)*	Hook ID Code	A-1339 Stock No.	L-1339 Stock No.	Weight Each (kg)	Dimensions (mm)							S-4320 Rep. Latch Stock No.	S-4339 Rep. Latch Stock No.
(in.)	(mm)						D	G	J	L	M	R	AA		
-	6	1.5	DA	1048982	1049103	0.29	72.6	18.5	23.6	107	16.0	74.9	38.1	1096325	-
1/4	7	2.0	HA	1048991	1049112	0.72	98.0	26.4	30.2	144	19.1	101	50.8	1096468	-
5/16	8	2.6	HA	1049000	1049121	0.71	98.0	26.4	30.2	144	19.1	100	50.8	1096468	-
3/8	10	4.0	IA	1049009	1049130	1.17	111	30.2	38.9	171	25.4	120	63.5	1096515	-
1/2	13	6.8	JA	1049018	1049149	2.39	142	36.6	45.2	213	29.7	150	76.2	1096562	-
5/8	16	10.3	KA	1049027	1049158	4.45	172	48.0	61.2	259	36.6	177	102	1096609	-
3/4	18-20	16.0	-	1049036	1049167	8.30	211	71.9	68.3	332	50.0	203	114	-	1048714
7/8**	22-23**	21.0	-	1049045	1049176	11.2	233	78.0	77.5	355	50.0	223	127	-	1048732

\* Ultimate Load is 4 times the Working Load Limit.

\*\* 7/8 in. (22-23 mm) size does not have cam, latch attaches to unique pin.



# Crosby® Grade 100 Foundry Hooks



**A-1359**  
Clevis Foundry Hook

- Forged Alloy Steel - Quenched and Tempered.
- Individually Proof Tested to 2-1/2 times the Working Load Limit with certification.
- Each hook has a Product Identification Code (PIC) for material traceability, along with the size and the name Crosby & U.S.A. in raised letters.
- Suitable for use with Grade 100 and Grade 80 chain.
- Fatigue rated at 1-1/2 times the Working Load Limit at 20,000 cycles.
- "Look for the Platinum Color - Crosby Grade 100 Alloy Products."
- Hook can be tip loaded at the reduced Working Load Limit, see below. Operator must ensure the load is retained properly in the hook.

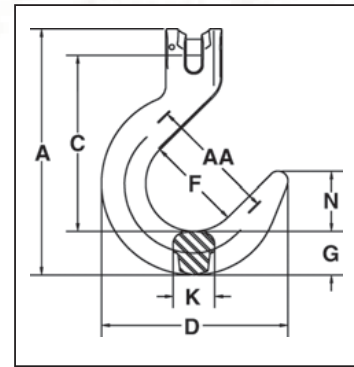

## A-1359 Clevis Foundry Hook

Chain Size		A-1359 Stock No.	Working Load Limit at Saddle of Hook (t)*	Working Load Limit at Tip of Hook (t)*	Weight Each (kg)	Dimensions (mm)							Deformation Indicators AA
(in.)	(mm)					A	C	D	F	G	K	N	
1/4	7	1049907	2.0	1.0	0.98	159.0	111.3	122.4	63.5	28.7	22.4	39.9	88.9
5/16	8	1049911	2.6	1.3	0.93	159.0	111.0	122.4	63.5	28.7	22.4	39.9	88.9
3/8	10	1049916	4.0	2.0	1.95	197.1	140.7	147.8	76.2	35.1	33.0	47.8	101.6
1/2	13	1049925	6.8	3.4	3.62	238.3	169.4	178.8	88.9	41.4	38.1	57.2	114.3
5/8	16	1049934	10.3	5.1	6.44	285.8	195.1	207.5	101.6	55.6	44.5	64.3	127.0
3/4	18-20	1049943	16.0	8.0	11.2	366.5	248.7	245.1	127.0	61.0	55.9	86.1	152.4
7/8	22-23	1049952	21.0	10.0	19.9	412.8	279.9	280.2	139.7	78.0	69.1	95.0	165.1

\* Ultimate Load is 4 times the Working Load Limit.



**A-1329**  
Eye Foundry Hook

- Forged Alloy Steel - Quenched and Tempered.
- Individually Proof Tested to 2-1/2 times the Working Load Limit with certification.
- Each hook has a Product Identification Code (PIC) for material traceability, along with the size and the name Crosby & U.S.A. in raised letters.
- Suitable for use with Grade 100 and Grade 80 chain.
- Fatigue rated at 1-1/2 times the Working Load Limit at 20,000 cycles.
- "Look for the Platinum Color - Crosby Grade 100 Alloy Products."
- Hook can be tip loaded at the reduced Working Load Limit, see below. Operator must ensure the load is retained properly in the hook.

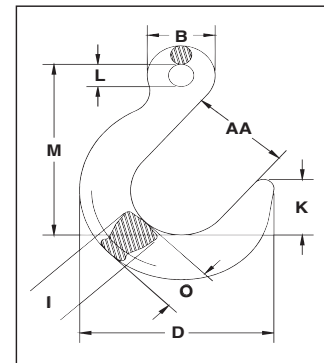

## A-1329 Eye Foundry Hook

Chain Size		A-1329 Stock No.	Working Load Limit at Saddle of Hook (t)*	Working Load Limit at Tip of Hook (t)*	Weight Each (kg)	Dimensions (mm)								Deformation Indicators AA
(in.)	(mm)					B	D	I	K	L	M	N	O	
1/4 - 5/16	7-8	1026280	2.6	1.3	.91	39.6	122.4	22.4	39.9	16.0	122.2	63.5	28.7	89
3/8	10	1026289	4.0	2.0	1.72	52.6	147.8	33.0	47.8	20.6	139.7	76.2	35.1	102
1/2	13	1026297	6.8	3.4	3.27	64.3	178.8	38.1	57.2	26.2	180.6	88.9	41.4	114
5/8	16	1026306	10.3	5.1	5.58	76.2	207.5	44.5	64.3	31.8	202.2	101.6	55.6	127
3/4	18-20	1026315	16.0	8.0	10.4	104.9	245.1	55.9	86.1	50.0	273.1	127.0	61.0	165
7/8	22-23	1026324	21.0	10.0	18.4	121.2	280.2	69.1	95.0	57.9	311.2	139.7	78.0	178
1	26	1026333	27.1	13.5	23.5	135.4	302.3	71.9	99.8	65.0	339.6	152.4	84.1	191
1 1/4	32	1026342	41.0	20.5	38.3	167.9	336.6	88.9	110.0	80.0	387.4	165.1	97.5	203

\* Ultimate Load is 4 times the Working Load Limit.

# Crosby® Grade 100 Clevis Grab Hooks



**A -1338**  
Cradle Grab Hook

- Forged Alloy Steel - Quenched and Tempered.
- Innovative cradle design allows for 100% efficiency of Grade 100 chain.
- Individually Proof Tested to 2-1/2 times the Working Load Limit with certification.
- Each hook has a Product Identification Code (PIC) for material traceability, along with the size and the name Crosby & U.S.A. in raised letters.
- Suitable for use with Grade 100 and Grade 80 chain.
- The use of A-1338 Cradle Grab Hook will allow 100 percent of the chain sling capacity. When used to hook back to chain leg to form a choker, the angle of the choke must be 120 degrees or greater. When used as a chain shortener, minimize twist of chain and ensure chain is fully engaged in hook.
- Fatigue rated at 1-1/2 times the Working Load Limit at 20,000 cycles.
- "Look for the Platinum Color - Crosby Grade 100 Alloy Products."



**L-1338**  
Cradle Grab Hook

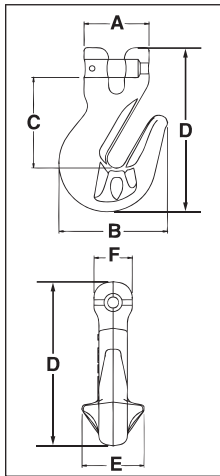

## A/L-1338 Cradle Grab Hook

Chain Size (in.) (mm)	Working Load Limit (t)*	A-1338 Stock No.	L-1338 Stock No.	Weight Each (kg)	Dimensions (mm)						S-4338 Replacement Latch Kit Stock No.
					A	B	C	D	E	F	
1/4 7	2.0	1049417	1049480	.20	43.7	64.5	55.9	98.5	38.1	22.4	1048426
5/16 8	2.6	1049426	1049489	.45	43.7	64.5	55.4	98.5	38.1	22.4	1048426
3/8 10	4.0	1049435	1049498	.82	47.0	78.5	65.5	119	46.5	27.7	1048435
1/2 13	6.8	1049444	1049507	1.78	60.7	97.3	83.3	149	57.2	36.1	1048444
5/8 16	10.3	1049453	1049516	3.18	67.8	115	97.8	179	74.5	44.5	1048453

\* Ultimate Load is 4 times the Working Load Limit.

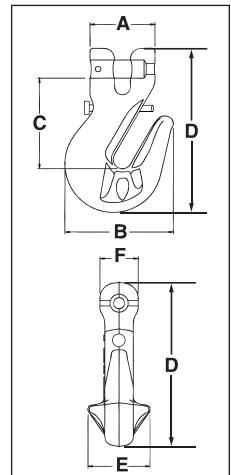

**A -1358**  
Grab Hook

- Forged Alloy Steel - Quenched and Tempered.
- Individually Proof Tested to 2-1/2 times the Working Load Limit with certification.
- Each hook has a Product Identification Code (PIC) for material traceability, along with the size and the name Crosby & U.S.A. in raised letters.
- Suitable for use with Grade 100 and Grade 80 chain.
- Fatigue rated at 1-1/2 times the Working Load Limit at 20,000 cycles.
- "Look for the Platinum Color - Crosby Grade 100 Alloy Products."



**L -1358**  
Grab Hook

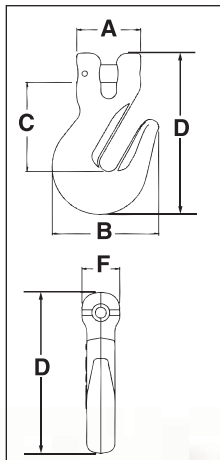

## A/L-1358 Grab Hook

Chain Size (in.) (mm)	Working Load Limit (t)*	A-1358 Stock No.	L-1358 Stock No.	Weight Each (kg)	Dimensions (mm)						S-4338 Replacement Latch Kit Stock No.
					A	B	C	D	E	F	
1/4 7	2.0	1049610	1049605	.20	43.7	64.5	55.9	98.5	38.1	22.4	1048426
5/16 8	2.6	1049629	1049614	.45	43.7	64.5	55.4	98.5	38.1	22.4	1048426
3/8 10	4.0	1049638	1049623	.82	47.0	78.5	65.5	119	46.5	27.7	1048435
1/2 13	6.8	1049647	1049634	1.78	60.7	97.3	83.3	149	57.2	36.1	1048444
5/8 16	10.3	1049656	1049643	3.18	67.8	115	97.8	179	74.5	44.5	1048453

\* Ultimate Load is 4 times the Working Load Limit.

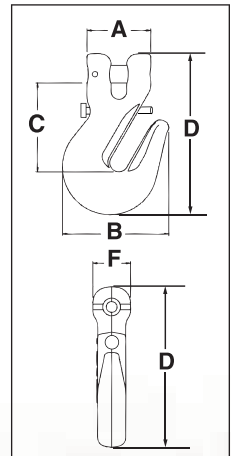

# Crosby® Grade 100 Eye Grab Hooks



**A-1328**  
Eye Grab Hook

- Forged Alloy Steel - Quenched and Tempered.
- Individually Proof Tested to 2-1/2 times the Working Load Limit with certification.
- Each hook has a Product Identification Code (PIC) for material traceability, along with the size and the name Crosby & U.S.A. in raised letters.
- Suitable for use with Grade 100 and Grade 80 chain.
- Fatigue rated at 1-1/2 times the Working Load Limit at 20,000 cycles.
- "Look for the Platinum Color – Crosby Grade 100 Alloy Products."

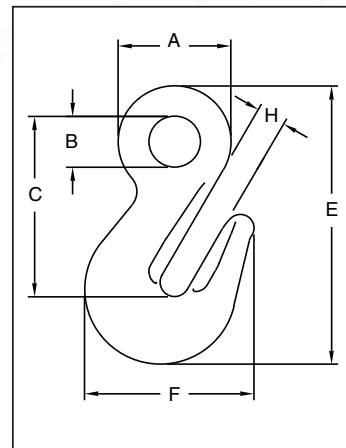

## A-1328 Eye Grab Hook

Chain Size		Working Load Limit (t)*	A-1328 Stock No.	Weight Each (kg)	Dimensions (mm)					
(in.)	(mm)				A	B	C	E	F	H
1/4 - 5/16	7 - 8	2.6	1026169	.98	44.5	19.1	70.9	109	66.3	11.2
3/8	10	4.0	1026187	1.6	52.3	23.9	84.6	130	78.5	13.5
1/2	13	6.8	1026196	3.3	65.0	28.4	104	162	97.3	16.8
5/8	16	10.3	1026205	6	78.0	33.3	125	194	115	20.0
3/4	18-20	16.0	1026214	10.0	82.6	38.1	137	223	152	23.9
7/8	22-23	20.0	1026223	13.1	100	46.0	165	257	166	27.7
1	26	27.1	1026232	18.9	113	50.8	183	291	197	30.2
1 1/4	32	41.0	1026241	39.4	143	60.5	231	371	241	38.1

\* Ultimate Load is 4 times the Working Load Limit.



# Crosby® Grade 100 SHUR-LOC® Hooks



**S-1316**  
Eye Hook

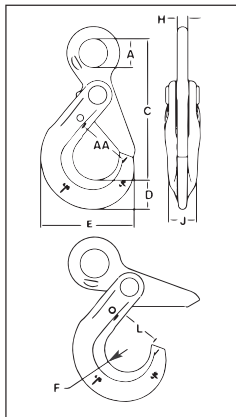

- Forged Alloy Steel - Quenched and Tempered.
- 25% stronger than Grade 80.
- Individually Proof Tested to 2-1/2 times the Working Load Limit with certification.
- Recessed trigger design is flush with the hook body, protecting the trigger from potential damage.
  - Easy to operate with enlarged thumb access.
- Positive Lock Latch is Self-Locking when hook is loaded.
- Eye style is designed with "Engineered Flat" to connect to S-1325 chain coupler.
- Suitable for use with Grade 100 and Grade 80 chain.
- The SHUR-LOC® hook, if properly installed and locked, can be used for personnel lifting applications and meets the intent of OSHA Rule 1926.1431(g)(1)(i)(A) and 1926.1501(g)(4)(iv)(B).
- Fatigue rated at 1-1/2 times the Working Load Limit at 20,000 cycles.
- "Look for the Platinum Color - Crosby Grade 100 Alloy Products."
- Forged Alloy Steel - Quenched and Tempered.
- 25% stronger than Grade 80.
- Individually Proof Tested to 2-1/2 times the Working Load Limit with certification.
- Recessed trigger design is flush with the hook body, protecting the trigger from potential damage.
  - Easy to operate with enlarged thumb access.
- Positive Lock Latch is Self-Locking when hook is loaded.



**S-1317**  
Clevis Hook

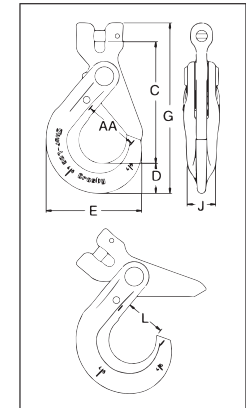

## SHUR-LOC® Hook Series with Positive Locking Latch S-1316 Eye Hook

Chain Size		Working Load Limit (t)*	S-1316 Stock No.	Weight Each (kg)	Dimensions (mm)								
(in.)	(mm)				A	C	D	E	F	H	J	L	AA
-	6	1.5	1022896	.39	19.8	100	20.1	66.0	17.0	7.87	16.0	29.5	38.1
1/4-5/16	7-8	2.6	1022914	.82	27.4	135	27.9	88.9	22.1	9.91	20.6	37.6	51.0
3/8	10	4.0	1022923	1.54	33.0	167	29.7	112	27.9	12.9	23.9	46.5	63.5
1/2	13	6.8	1022932	2.72	41.9	209	42.4	139	32.0	17.0	29.5	56.4	76.2
5/8	16	10.3	1022941	6.85	55.9	256	51.8	167	38.1	22.1	38.1	67.3	89.0
3/4	18-20	16.0	1022942	8.62	66.0	274	56.4	197	51.1	22.1	51.6	89.4	-
7/8	22	20.0	1022943	12.7	72.9	317	62.2	222	57.7	24.9	55.9	97.3	-
1	26	27.1	1022944	22.5	80.0	371	81.5	251	62.5	32.0	68.1	104	-

\* Minimum Ultimate Load is 4 times the Working Load Limit.

## S-1317 Clevis Hook

Chain Size		Working Load Limit (t)*	S-1317 Stock No.	Weight Each (kg)	Dimensions (mm)						
(in.)	(mm)				C	D	E	G	J	L	AA
-	6	1.5	1028991	.35	87.4	20.1	66.0	121	16.0	29.0	38.1
1/4	7	2.0	1029000	.82	114	27.9	89.0	159	20.6	35.1	51.0
5/16	8	2.6	1029009	.82	114	27.9	89.0	159	20.6	35.1	51.0
3/8	10	4.0	1029018	1.66	140	29.7	112	192	24.1	46.5	63.5
1/2	13	6.8	1029027	3.08	173	42.4	139	242	29.5	56.4	76.2
5/8	16	10.3	1029036	5.40	209	51.8	167	295	38.1	67.3	89.0
3/4	18-20	16.0	1029071	6.80	239	56.4	197	336	51.6	89.4	-
7/8	22	20.0	1029080	12.7	283	62.2	222	392	55.9	97.3	-
1	26	27.1	1029089	22.5	319	81.5	251	468	68.1	104	-

\* Minimum Ultimate Load is 4 times the Working Load Limit.

# Crosby® Grade 100 SHUR-LOC® Hooks



**S-1326**  
SHUR-LOC® Swivel Hook

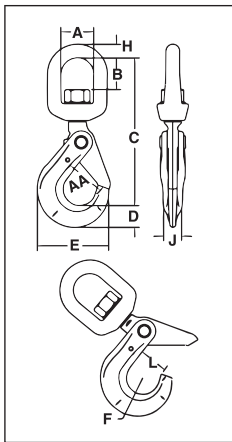

- Forged Alloy Steel - Quenched and Tempered.
- Individually Proof Tested at 2-1/2 times the Working Load Limit with certification.
- Recessed trigger design is flush with the hook body, protecting the trigger from potential damage.
  - Easy to operate with enlarged thumb access.
- Positive Lock Latch is Self-Locking when hook is loaded.
- Rated for both Wire Rope, (reference page 117 for Wire Rope), and use with Grade 80/100 Chain.
- G-414 Heavy Thimble should be used with wire rope slings.
- Trigger Repair Kit available (S-4316). Consists of spring, roll pin and trigger.
- S-13326 Swivel Hook utilizes anti-friction bearing design which allows hook to rotate freely under load.
- Fatigue rated.
- The SHUR-LOC® hook, if properly installed and locked, can be used for personnel lifting applications and meets the intent of OSHA Rule 1926.1431(g)(1)(i)(A) and 1926.1501(g)(4)(iv)(B).
- “Look for the Platinum Color – Crosby Grade 100 Alloy Products.”
- U.S. Patent 5,381,650 and foreign equivalents. Use in corrosive environment requires shank and nut inspection in accordance with ASME B30.10-1.10.4(b)(5)(c)2009.



**S-13326**  
SHUR-LOC® Swivel Hook

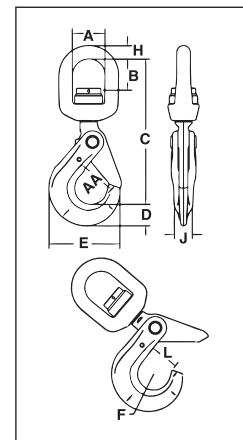

## S-1326 SHUR-LOC® Swivel Hooks • Suitable for infrequent, non-continuous rotation under load.

Chain Size		S-1326 Stock No.	Grade 100 Alloy Chain Working Load Limit (t) 4:1*	Weight Each (kg)	Dimensions (mm)									
(in.)	(mm)				A	B	C	D	E	F	H	J	L	AA
-	6	1004304	1.5	.57	38.1	33.5	189	20.1	66.0	17.0	12.7	16.0	28.7	38.1
1/4-5/16	7-8	1004313	2.6	1.18	44.5	40.4	235	27.9	88.9	22.1	16.0	20.6	35.1	51.0
3/8	10	1004322	4.0	2.13	50.8	43.9	274	29.7	112	27.9	19.1	23.9	44.5	63.5
1/2	13	1004331	6.8	3.92	63.5	60.5	351	42.4	139	32.0	25.4	29.5	53.6	76.2
5/8	16	1004340	10.3	7.71	69.9	68.6	410	51.8	167	38.1	28.7	38.1	63.2	89.0
3/4	18-20	1004349	16.0	10.9	71.9	64.0	442	56.4	197	51.1	27.9	51.6	89.4	127
7/8	22	1004358	20.0	13.2	87.4	81.0	418	62.2	222	57.4	33.0	55.9	97.3	152

\* Ultimate Load is 4 times the Working Load Limit.

## S-13326 SHUR-LOC® Swivel Hooks • Suitable for frequent rotation under load.

Chain Size		S-13326 Stock No.	Grade 100 Alloy Chain Working Load Limit (t) 4:1*	Weight Each (kg)	Dimensions (mm)									
(in.)	(mm)				A	B	C	D	E	F	H	J	L	AA
-	6	1004404	1.5	.57	38.1	29.0	157	20.1	66.0	17.0	12.7	16.0	28.7	38.1
1/4-5/16	7-8	1004413	2.6	1.18	44.5	38.6	192	27.9	89.0	22.1	16.0	20.6	35.1	51.0
3/8	10	1004422	4.0	2.13	51.0	40.9	226	29.7	112	27.9	19.1	23.9	46.5	63.5
1/2	13	1004431	6.8	3.92	63.5	51.6	282	42.4	138	32.0	25.4	29.5	53.5	76.2
5/8	16	1004440	10.3	7.71	70.0	57.2	320	52.0	167	38.1	28.7	38.1	63.0	89.0

\* Ultimate Load is 4 times the Working Load Limit.

# Crosby® Grade 100 Chain Fittings



**S-1325A**  
Chain Coupler

- Designed to connect Grade 100 chain fittings produced with “Engineered Flat” to Grade 100 chain.
- Forged Alloy Steel - Quenched and Tempered.
- Suitable for use with Grade 100 and Grade 80 chain.
- Individually Proof Tested to 2-1/2 times the Working Load Limit with certification.
- Locking system that provides for simple assembly and disassembly – no special tools required.
- Fatigue rated at 1-1/2 times the Working Load Limit at 20,000 cycles.
- “Look for the Platinum Color – Crosby Grade 100 Alloy Products.”

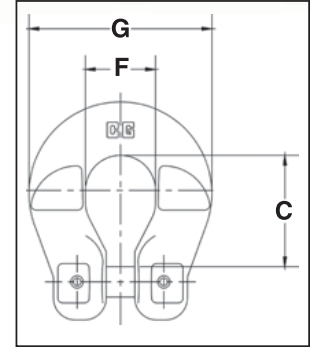

**Crosby 8/10™**

**“QT”**  
QUENCHED & TEMPERED

**Fatigue Rated**

## S-1325A Grade 100 Chain Coupler

Chain Size		S-1325A Stock No.	Working Load Limit (t)*	Weight Each (kg)	Dimensions (mm)		
(in.)	(mm)				C	F	G
-	6	1098496	1.5	.11	26.2	19.3	44.7
1/4	7	1098500	2	.23	35.8	22.4	59.0
5/16	8	1098504	2.5	.23	35.6	22.4	59.0
3/8	10	1098508	4	.34	46.7	30.0	69.0
1/2	13	1098512	6.8	.75	55.6	38.1	94.5
5/8	16	1098516	10.3	.86	71.4	49.8	112

\* Minimum Ultimate Load is 4 times the Working Load Limit.



**S-1311N**  
Chain Shortener Link

- Alloy Steel - Quenched and Tempered.
- Individually Proof Tested to 2-1/2 times the Working Load Limit with certification.
- Suitable for use with Grade 100 and Grade 80 chain.
- Spring loaded chain locking system keeps chain in place under slack conditions.
- The use of S-1311N Chain Shortener will allow 100 percent of the chain sling capacity.
- Fatigue rated at 1-1/2 times the Working Load Limit at 20,000 cycles.
- “Look for the Platinum Color - Crosby Grade 100 Alloy Products.”

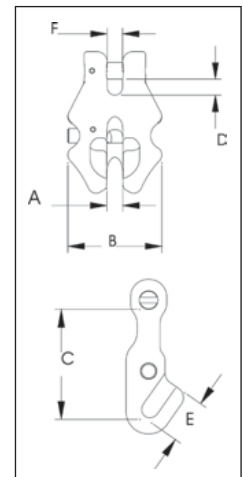

**Crosby 8/10™**

**“QT”**  
QUENCHED & TEMPERED

**Fatigue Rated**

## S-1311N Grade 100 Chain Shortener Link

Chain Size		S-1311N Stock No.	Working Load Limit (t)*	Weight Each (kg)	Dimensions (mm)					
(in.)	(mm)				A	B	C	D	E	F
-	6	1017860	1.5	.34	7.61	44.7	46.5	7.37	19.3	7.37
1/4	7	1017869	2.0	.45	8.64	51.8	55.1	8.64	22.4	8.38
5/16	8	1017878	2.6	.45	10.2	59.9	64.3	9.91	25.7	9.65
3/8	10	1017897	4.0	.68	12.2	72.1	78.0	12.2	31.2	11.7
1/2	13	1017906	6.8	1.47	15.7	90.4	95.8	15.5	39.9	15.0
5/8	16	1017915	10.3	2.54	18.5	108	118	18.5	48.5	17.8

\* Minimum Ultimate Load is 4 times the Working Load Limit.





**A-1355**  
Chain Choker Hook

- Forged Alloy Steel - Quenched and Tempered.
- Individually Proof Tested with certification.
- Rated for Grade 100 chain in choker applications.
- Each hook has a Product Identification Code (PIC) for material traceability, along with the size and the name Crosby & U.S.A. in raised letters.
- 25% stronger than Grade 80.
- Fatigue rated at 1-1/2 times the Working Load Limit at 20,000 cycles.
- "Look for the Platinum Color - Crosby Grade 100 Alloy Products."
- For use with S-1325 Chain Coupler Link.

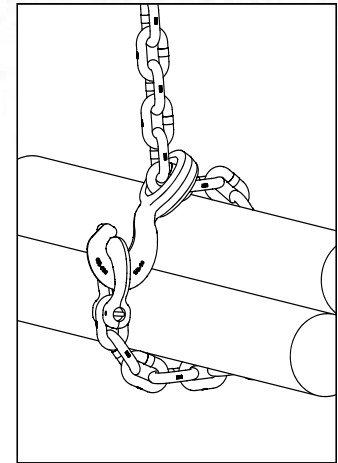

Crosby 8/10™

"QT"  
QUENCHED & TEMPERED

Fatigue Rated

**A-1355 Chain Choker Hook**

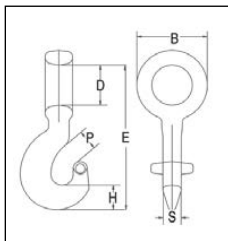

Grade 100 Alloy Chain Size		Working Load Limit (t)*	A-1355 Stock No.	Weight Each (kg)	Dimensions (mm)					
(in.)	(mm)				B	D	E	H	P	S
1/4-5/16	7-8	2.6	1015204	.34	52.1	30.0	123	20.1	17.5	16.5
3/8	10	4.0	1015213	.74	67.6	39.9	154	23.6	23.6	17.5
1/2	13	6.8	1015222	1.42	85.1	51.6	193	30.0	32.0	23.8
5/8	16	10.3	1015231	3.16	107	64.0	246	39.1	28.4	30.0

\* Ultimate Load is 4 times the Working Load Limit.

**SLING IDENTIFICATION TAG KITS**



Stamped ID Tag



RFID Equipped Tags



Forged ID Tags



Stamped RFID Tag



Wire Rope



RFID QUIC Tag

**Stamped ID Tags**

- Octagonal metal sling tag.
- Prestamped - easy to add sling length, Working Load Limit, name, etc.
- Front side is shown - reverse is blank.
- Available with or without welded attached ring.
- Attaching ring size is 5mm x 50mm.
- Available completely blank for wire rope sling applications.
- Gold painted.

**ID Tags**

- Heavy Duty tags.
- 1-5/16" diameter ring opening (will fit 1/4" - 5/8" A-1337).
- Chain tags meet requirements of ASME B30.9 for Sling Identification.
- Raised edge and recessed pads to protect lettering.
- Raised lettering for quick reference.



ID Tag Stock No. with Ring	ID Tag Stock No. without Ring	Application
1152445	1200829	For single leg sling: 90°
1152444	1200830	For multi-leg sling: 45°/60°
1152514	1200837	Blank Tag

Stock No.	Style	Material Type	RFID Equipped	Tag Size (mm)	Weight Each (kg)
115369	Chain	Cast Stainless Steel	Yes	160 x 42	.21
115350	Wire Rope	Cast Stainless Steel	Yes	43 x 33.3	.03
115217	Chain	Forged Steel	No	146 x 48	.18
115353	Chain	Stamped Zinc Plated Steel	Yes	5-3/4 x 1-5/8	.29
115355	Wire Rope	Stamped Zinc Plated Steel	Yes	1-11/16 x 1-5/16	.04
122469	Zip Tie	High Crystalline Polyamide	Yes	193.675	1.4

# RFID Field Installation Instruction Manual



Crosby Red-Pin® Shackles



Crosby Eliminator®



McKissick® Blocks



CrosbyIP® Lifting Clamps



Crosby Clamp-Co®  
Lifting Clamps



Crosby® Hoist Rings

Many standard Crosby products come from the factory, equipped with RFID chips that you can program and utilize in your inspection efforts. However, what if you want to retrofit an RFID chip to a Crosby product in the field? No problem!! We now have a NEW installation instruction manual available to attach RFID chips to selected Crosby Products. The installation instructions will show you the step-by-step process to add an RFID chip to the products to the left.

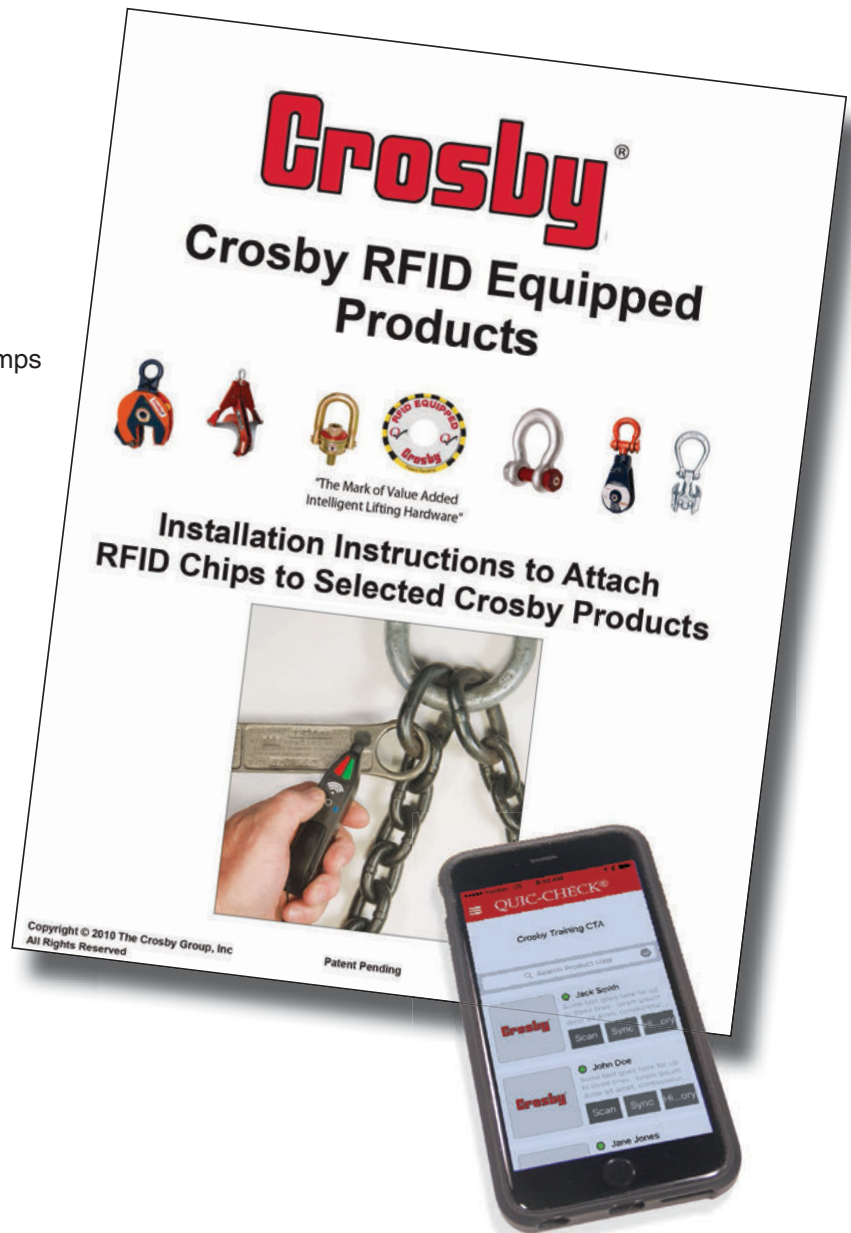

## WORKING LOAD LIMIT – 4 TO 1 DESIGN FACTOR

Nominal Size of Sling		Single Leg	Two Leg Slings		Triple and Four-Leg Slings		Choker Hitch *
			0° < β ≤ 45°	45° < β ≤ 60°	0° < β ≤ 45°	45° < β ≤ 60°	
(in.)	(mm)	t	t	t	t	t	t
7/32	6	1,12	1,60	1,12	2,36	1,70	0,90
1/4 (9/32)	7	1,50	2,12	1,50	3,15	2,24	1,20
5/16	8	2	2,80	2	4,25	3	1,60
3/8	10	3,15	4,25	3,15	6,70	4,75	2,50
1/2	13	5,30	7,50	5,30	11,20	8	4,25
5/8	16	8	11,20	8	17	11,80	6,40
3/4	19-20	11,20	16	11,20	23,60	17	9
7/8	22	15	21,20	15	31,50	22,40	12
1	26	21,20	30	21,20	45	31,50	17
1-1/4	32	31,50	45	31,50	67	47,50	25,20

\* For choker applications, the Working Load Limit must be reduced by 20%. The Crosby A-1338 cradle grab hook and S1311N chain shortener link does not require any reduction of the Working Load Limit. The design factor of 4 to 1 on Spectrum® 8 Alloy Chain agrees with the design factor used by the International Standards Organization (I.S.O.) and ANSI B30.9 and is the preferred set of Working Load Limit values to be used.

### SINGLE LEG SLING

Spectrum 8 Chain Size (in.) (mm)	Grade 8 Chain Stock No.	Master Link A-342 Stock No.	Master Link Assembly A-345 Stock No.	Master Link with Flat A-344 Stock No.	Master Link Assembly A-347 Stock No.	LOK-A-LOY® A-1337 Stock No.	Chain Coupler S-1325 Stock No.	Clevis Sling Hook A-1339 A-339** Stock No.	SHUR-LOC® Clevis Hook S-1317 Stock No.	Latching Clevis Chain Hook S-314A Stock No.	Clevis Grab Hook A-338 Stock No.	Cradle Grab Hook A-1338 Stock No.	Eye Sling Hook A-1327 Stock No.	Eye Foundry Hook A-1329 Stock No.
1/4 7	273527	1014266	—	1256862	—	1015104	1098500	1048991	1029000	1225021	1027659	1049417	1003764	1026280
5/16 8	273536	1014266 1014280 1014285	—	1256932	—	1015113	1098504	1049000	1029009	1225021	—	1049426	—	1026280
3/8 10	273545	1014285 1014319	—	1257002	—	1015122	1098508	1049009	1029018	1225091	1027677	1049435	1003773	1026289
1/2 13	273554	1014319 1014331	—	1257072	—	1015136	1098512	1049018	1029027	1225161	1027686	1049444	1003782	1026297
5/8 16	273563	1014331 1014348	—	1257212	—	1015145	1098516	1049027	1029036	1225162	1027695	1049453	1003791	1026306
3/4 20	273572	1014348 1014365	—	1257382	—	1015154	—	1027793**	—	—	1027702	—	1003808	1026315
7/8 22	273581	1014365 1014388	—	1257422	—	1015163	—	1027800**	—	—	1027711	—	1003817	1026324
1 26	273590	1014388 1014404	—	1257492	—	1015172	—	—	—	—	—	—	—	—
1-1/4 32	273599	1014404 1014422	—	1257632	—	1015181	—	—	—	—	—	—	—	—

+ Available in eye style. \*\* Old style A-339

### DOUBLE LEG SLING

Spectrum 8 Chain Size (in.) (mm)	Grade 8 Chain Stock No.	Master Link A-342 Stock No.	Master Link Assembly A-345 Stock No.	Master Link with Flat A-344 Stock No.	Master Link Assembly A-347 Stock No.	LOK-A-LOY® A-1337 Stock No.	Chain Coupler S-1325 Stock No.	Clevis Sling Hook A-1339 A-339** Stock No.	SHUR-LOC® Clevis Hook S-1317 Stock No.	Latching Clevis Chain Hook S-314A Stock No.	Clevis Grab Hook A-338 Stock No.	Cradle Grab Hook A-1338 Stock No.	Eye Sling Hook A-1327 Stock No.	Eye Foundry Hook A-1329 Stock No.
1/4 7	273527	1014266	—	1256932	—	1015104	1098500	1048991	1029000	1225021	1027659	1049417	1003764	1026280
5/16 8	273536	1014280	—	1257002	—	1015113	1098504	1049000	1029009	1225021	—	1049426	—	1026280
3/8 10	273545	1014319	—	1257072	—	1015122	1098508	1049009	1029018	1225091	1027677	1049435	1003773	1026289
1/2 13	273554	1014331	—	1257282	—	1015136	1098512	1049018	1029027	1225161	1027686	1049444	1003782	1026297
5/8 16	273563	1014348	—	1257422	—	1015145	1098516	1049027	1029036	1225162	1027695	1049453	1003791	1026306
3/4 20	273572	1014365	—	1257492	—	1015154	—	1027793**	—	—	1027702	—	1003808	1026315
7/8 22	273581	1014388	—	1257562	—	1015163	—	1027800**	—	—	1027711	—	1003817	1026324
1 26	273590	1014404	—	1257632	—	1015172	—	—	—	—	—	—	—	—
1-1/4 32	273599	1014422	—	—	—	1015181	—	—	—	—	—	—	—	—

+ Available in eye style. \*\* Old style A-339

### TRIPLE AND QUADRUPE LEG SLING

Spectrum 8 Chain Size (in.) (mm)	Grade 8 Chain Stock No.	Master Link A-342 Stock No.	Master Link Assembly A-345 Stock No.	Master Link with Flat A-344 Stock No.	Master Link Assembly A-347 Stock No.	LOK-A-LOY® A-1337 Stock No.	Chain Coupler S-1325 Stock No.	Clevis Sling Hook A-1339 A-339** Stock No.	SHUR-LOC® Clevis Hook S-1317 Stock No.	Latching Clevis Chain Hook S-314A Stock No.	Clevis Grab Hook A-338 Stock No.	Cradle Grab Hook A-1338 Stock No.	Eye Sling Hook A-1327 Stock No.	Eye Foundry Hook A-1329 Stock No.
1/4 7	273527	—	1014739	—	1257832	1015104	1098500	1048991	1029000	1225021	1027659	1049417	1003764	1026280
5/16 8	273536	—	1014742	—	1257972	1015113	1098504	1049000	1029009	1225021	—	1049426	—	1026280
3/8 10	273545	—	1014766	—	1258142	1015122	1098508	1049009	1029018	1225091	1027677	1049435	1003773	1026289
1/2 13	273554	—	1014779	—	1258182	1015136	1098512	1049018	1029027	1225161	1027686	1049444	1003782	1026297
5/8 16	273563	—	1014807	—	1258332	1015145	1098516	1049027	1029036	1225162	1027695	1049453	1003791	1026306
3/4 20	273572	—	1014810	—	1258402	1015154	—	1027793**	—	—	1027702	—	1003808	1026315
7/8 22	273581	—	1014845	—	1258462	1015163	—	1027800**	—	—	1027711	—	1003817	1026324
1 26	273590	—	1014845	—	—	1015172	—	—	—	—	—	—	—	—
1-1/4 32	273599	—	1014986	—	—	1015181	—	—	—	—	—	—	—	—

+ Available in eye style. \*\* Old style A-339



# Crosby® Grade 80 Chain Sling Configurations



## HOW TO MAKE YOUR CROSBY® GRADE 80 ALLOY CHAIN SLING

Follow these simple steps in making a sling assembly:

1. Determine the maximum load to be lifted by the sling assembly.
2. Choose the type of sling assembly suited for the shape of the load and the size of the sling assembly for the load to be lifted. The decision must take into account the angle of the sling legs in multileg slings.
3. Determine the overall reach from bearing point of master link to bearing point on hook (see Fig. 1).
4. Select components, assemble chain and components.
5. Affix sling identification tag to sling. The tag is available from your Authorized Crosby Distributor.

Each sling shall be marked to show: name or trademark of manufacturer, grade, nominal chain size, number of legs, rated load for the type(s) of hitch(es) used and angle upon which it is based (reach).

If measurement comes in the link, cut the following link. For two leg type slings, count the links and use an even number for clevis hooks



Fig. 1

and an odd number for eye hooks. This will position hooks in the same plane. In multileg slings always use the same number of links in each leg.

When using chain slings in choker applications, the Working Load Limit must be reduced by 20%. Crosby recommends a minimum angle of choke of 120 degrees. Consult Crosby when planning to use an angle of choke of less than 120 degrees. If Crosby A-1338 cradle grab hooks are used at a minimum angle of choke of 120 degrees, the full sling rated WLL can be utilized.



In shortening applications, a 20% reduction of the Working Load Limit is required except when using the Crosby A-1338 Cradle Grab Hooks, S-1311 Chain Shortener Link, the A-1355 Chain Choker Hook in conjunction with the S-1325 Chain Coupler Link, or the Crosby **ELIMINATOR®** shortener link. They can be used without any reduction to the Working Load Limit.



The Slings shown here are standard assemblies that can be made from "Proof Tested" Crosby Components and Alloy Chain supplied by your authorized Crosby distributor. Assemblies must include chain sling identification tag (not shown, see page 238).

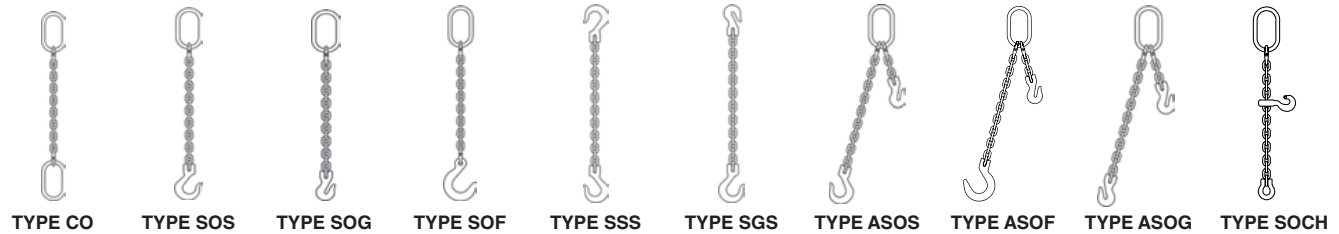

Type	Description	Type	Description
CO	Single Chain Sling with Master Link each end	SGS	Single Chain Sling with Grab Hook and Sling Hook
SOS	Single Chain Sling with Master Link and Sling Hook	ASOS	Adjustable Single Chain with Master Link and Sling Hook
SOG	Single Chain Sling with Master Link and Grab Hook	ASOF	Adjustable Single Chain Sling with Master Link and Foundry Hook
SOF	Single Chain Sling with Master Link and Foundry Hook	ASOG	Adjustable Single Chain Sling with Master Link and Grab Hook
SSS	Single Chain Sling with Sling Hook each end	SOCH	Single with 1355 Choker

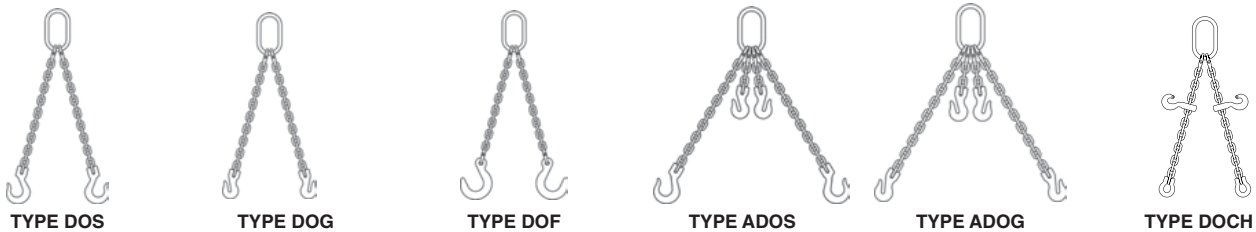

Type	Description	Type	Description
DOS	Double Chain Sling with Master Link and Sling Hook	ADOS	Adjustable Double Chain Sling with Master Link and Sling Hook
DOG	Double Chain Sling with Master Link and Grab Hook	ADOG	Adjustable Double Chain Sling with Master Link and Grab Hook
DOF	Double Chain Sling with Master Link and Foundry Hook	DOCH	Double with 1355 Choker

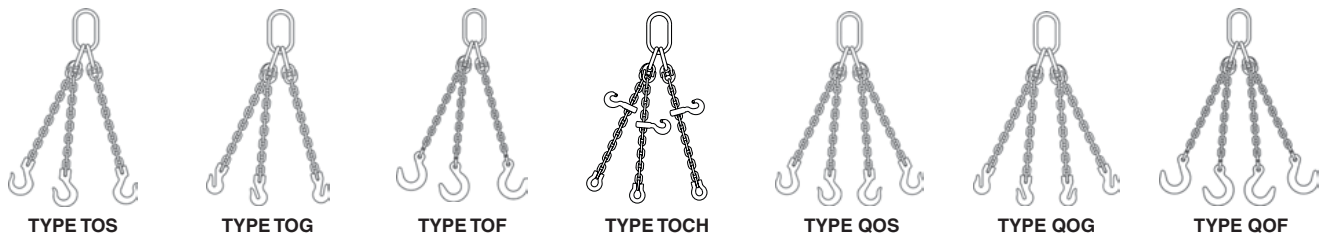

Type	Description	Type	Description
TOS	Triple Chain Sling with Master Link and Sling Hook	QOS	Quadruple Chain Sling with Master Link and Sling Hook
TOG	Triple Chain Sling with Master Link and Grab Hook	QOG	Quadruple Chain Sling with Master Link and Grab Hook
TOF	Triple Chain Sling with Master Link and Foundry Hook	QOF	Quadruple Chain Sling with Master Link and Foundry Hook
TOCH	Triple Chain Sling with 1355 Choker		

**Spectrum 8®**  
Alloy Chain

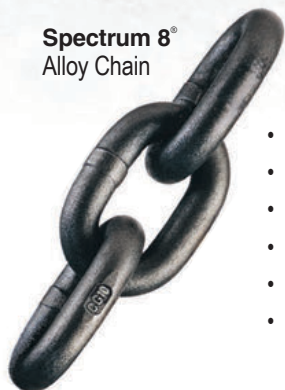

- Alloy Steel.
- Heat Treated.
- Finish – Black rust preventative coating.
- Permanently embossed with CG (Crosby Group) and 8 (Grade).
- Proof Tested at 2 times the Working Load Limit with certification.
- Standard container – fiber drum.

**Grade 80 Alloy Chain (Recommended for overhead lifting applications)**

Chain Size (mm)	Spec. 8 Drum Stock No.	Meters Per Drum	Dimensions (mm)	Working Load Limit (t)*	Weight Per Meter (kg)
6	1244915	200	6 x 18	1.1	.80
7	1244985	200	7 x 21	1.5	1.05
8	1245055	200	8 x 24	2.0	1.25
10	1245125	200	10 x 30	3.2	2.20
13	1245195	150	13 x 39	5.3	3.80
16	1245265	100	16 x 48	8.0	5.70
18	1245305	50	18 x 54	10.0	7.30
19	1245356	50	19 x 57	11.2	8.03
20	1245396	50	20 x 60	12.5	9.00
22	1245426	50	22 x 66	15.0	10.90
23	1245453	50	23 x 69	16.0	10.90
26	1245496	50	26 x 78	21.2	15.20
32	1245514	20	32 x 96	31.5	23.00

\* Proof loaded at 2 times Working Load Limit. Ultimate Load is 4 times the Working Load Limit.

**Crosby provides two methods of attaching Spectrum 8® chain to Crosby fittings.**

**CONNECTING AND COUPLER CHAIN LINKS**



**A-1337**  
**LOK-A-LOY®**  
Connecting Link  
Refer to page 227



**S-1325**  
**Grade 100**  
Coupler Link  
Refer to page 237



**A-342**  
Alloy Master Link

**Ratings below are for use with chain slings fabricated in accordance with ASME B30.9. For other applications, see pages 160.**

- Alloy Steel – Quenched and Tempered.
- Individually Proof Tested with certification. (See pages 160 for Proof Test values.)
- Proof Tested with 60% inside width special fixtures sized to prevent localized point loading per ASTM A-952. Reference page 276.
- Meets or exceeds all requirements of ASME B30.26 including identification, ductility, design factor, proof load and temperature requirements. Importantly, these links meet other critical performance requirements including fatigue life, impact properties and material traceability, not addressed by ASME B30.26.
- Forgings have a Product Identification Code (PIC) for material traceability, along with the size, the name Crosby and USA in raised lettering.
- Selected sizes designated with “W” in the size column have enlarged inside dimensions to allow additional room for sling hardware and crane hook.
- Incorporates patented **QUIC-CHECK**® deformation indicators.

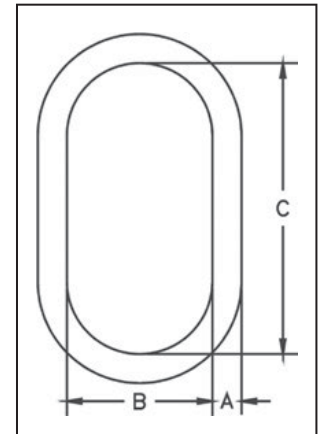

## A-342 Alloy Master Links

Size		A-342 Stock No.	Weight Each (kg)	Chain Size		Single Leg		Double Leg		Dimensions (mm)			
(in.)	(mm)			(mm)	(in.)	WLL Based on Grade 80 Chain (t)*	WLL Based on Grade 100 Chain (t)*	WLL Based on Grade 80 Chain 60° Sling Angle (t)*	WLL Based on Grade 100 Chain 60° Sling Angle (t)*	A	B	C	Deformation Indicator
13W	1/2W	1014266	0.59	7	1/4	1.50	2.00	2.12	2.80	15.7	71.1	127	89
				8	5/16	2.00	2.50	2.80	-				
16	5/8	1014280	0.69	8	5/16	2.00	2.50	2.80	3.55	15.7	76.2	152	89
				10	3/8	3.15	-	-	-				
19W	3/4W	1014285	0.91	10	3/8	3.15	4.00	4.25	-	18.5	81.3	152	102
				10	3/8	3.15	4.00	4.25	5.60				
22W	7/8W	1014319	1.50	13	1/2	5.30	6.70	-	-	22.4	95.3	162	114
				13	1/2	5.30	6.70	7.50	9.50				
26W	1W	1014331	2.77	16	5/8	8.00	10.0	11.2	-	27.9	109	191	140
				16	5/8	8.00	10.0	11.2	14.0				
32W	1-1/4W	1014348	5.44	19	3/4	11.2	14.0	16.0	-	33.8	140	241	178
				19	3/4	11.2	14.0	16.0	20.0				
38W	1-1/2W	1014365	8.44	22	7/8	15.0	18.8	21.2	26.5	40.9	150	267	191
				22	7/8	15.0	18.8	21.2	26.5				
44	1-3/4	1014388	11.4	26	1	21.2	27.0	-	-	44.5	152	305	191
				26	1	21.2	27.0	30.0	38.0				
51	2	1014404	16.8	32	1-1/4	31.5	-	-	-	50.8	178	356	229
				32	1-1/4	31.5	40.0	45.0	56.0				
57	2-1/4	1014422	24.5	32	1-1/4	31.5	40.0	45.0	56.0	57.2	203	406	254
2-1/2	63	1014468	68.5	1-1/4	32	72300	90400	125200	156600	2.5	8.38	16.00	11.00

\* Chain slings require that the Minimum Ultimate Load be 4 times the Working Load Limit. Refer to page 160 to determine products actual Ultimate Load. Proof Test Load equals or exceeds the requirement of ASTM A952(8.1) and ASME B30.9-1.4 for the chain size and number of legs. See chart on page 240 for other sling angles.



## Alloy Master Link Assembly with Engineered Flat



**A-345**  
Master Link Assembly  
with Engineered Flat

**Ratings below are for use with chain slings fabricated in accordance with ASME B30.9. For other applications, see pages 161.**

- Alloy Steel – Quenched and Tempered.
- Individually Proof Tested with certification. (See pages 161 for Proof Test values.)
- Proof Tested with 60% inside width special fixtures sized to prevent localized point loading per ASTM A-952. Reference page 276.
- Meets or exceeds all requirements of ASME B30.26 including identification, ductility, design factor, proof load and temperature requirements. Importantly, these links meet other critical performance requirements including fatigue life, impact properties and material traceability, not addressed by ASME B30.26.
- Forgings have a Product Identification Code (PIC) for material traceability, along with the size, the name Crosby and USA in raised lettering.
- Selected sizes designated with “W” in the size column have enlarged inside dimensions to allow additional room for sling hardware and crane hook.
- Incorporates patented **QUIC-CHECK**<sup>®</sup> deformation indicators.

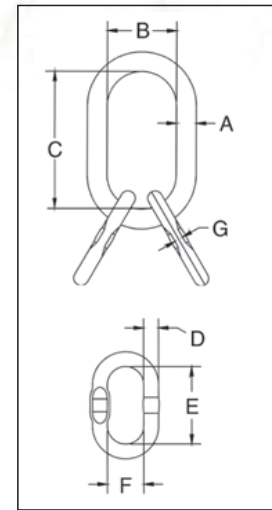

### A-345 Master Link Assembly with Engineered Flat (for use with S-1325A coupler link)

Size		A-345 Stock No.	Weight Each (kg)	Chain Size		Three and Four Leg Sling		Dimensions (mm)								Engineered Flat for S-1325 (mm) – (in.)
(mm)	(in.)			(mm)	(in.)	WLL Based on Grade 80 Chain 0-45° Sling Angle (t)*	WLL Based on Grade 100 Chain 0-45° Sling Angle (t)*	A	B	C	D	E	F	G	Deformation Indicator	
19W	3/4W	1014739	1.59	7	1/4	3.15	4.20	19	81.3	152	14.2	85.1	45.0	7.62	102	7-8mm – 1/4-5/16"
				8	5/16	4.25	-									
22W	7/8W	1014742	2.18	8	5/16	4.25	5.30	22	95.3	162	14.2	85.1	45.0	7.62	114	-
				10	3/8	6.70	-									
26W	1W	1014766	4.22	10	3/8	6.70	8.00	26	109	191	19.1	100	59.9	8.38	140	10mm – 3/8"
				13	1/2	11.2	14.0									
32W	1-1/4W	1014779	7.17	16	5/8	17.0	21.2	32	140	241	25.4	160	89.9	13.0	178	13mm – 1/2"
				19	3/4	23.6	-									
38W	1-1/2W	1014807	15.47	19	3/4	23.6	-	38	150	267	31.8	180	100	16.5	191	16mm – 5/8"
				20	3/4	23.6	30.0									
44	1-3/4	1014810	20.87	20	3/4	23.6	30.0	44	152	305	38	152	102	-	190	No Flat
				22	7/8	31.5	39.4									
57	2-1/4	1014845	44.00	26	1	45.0	57.0	57	203	406	48	203	140	-	254	No Flat
				32	1-1/4	67.0	85.0									
83	3-1/4	1014986	116	26	1	45.0	57.0	83	254	508	63	286	203	-	343	No Flat
				32	1-1/4	67.0	85.0									

\* Chain slings require that the Minimum Ultimate Load be 4 times the Working Load Limit. Refer to page 161 to determine products actual Ultimate Load. Proof Test Load equals or exceeds the requirement of ASTM A952(8.1) and ASME B30.9-1.4 for the chain size and number of legs. See chart on page 240 for other sling angles.

# Welded Master Links Assembly with Engineered Flat



**A-344**  
Welded Master Link  
with Engineered Flat

**Ratings below are for use with chain slings fabricated in accordance with ASME B30.9. For other applications, see page 162.**

- Alloy Steel - Quenched and Tempered.
- Individually Proof Tested with certification. (See page 162 for proof test values.)
- Proof Tested with 60% inside width special fixtures sized to prevent localized point loading per ASTM A-952. Reference page 276.
- Meets or exceeds all requirements of ASME B30.26 including identification, ductility, design factor, proof load and temperature requirements. Importantly, these links meet other critical performance requirements including fatigue life, impact properties and material traceability, not addressed by ASME B30.26.
- Each link has a Product Identification Code (PIC) for material traceability, along with the size and the name Crosby® or “CG”.
- Large inside width and length to allow additional room for sling hardware and crane hook.
- Engineered flat for use with S-1325A coupler link.

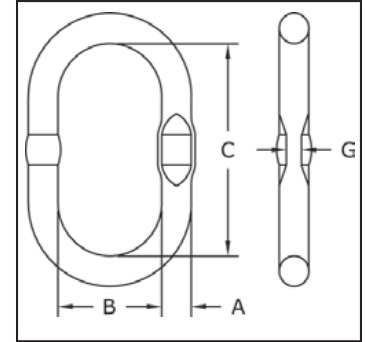

12mm through 31mm have Engineered Flat



## A-344 Welded Master Link with Engineered Flat

Size		A-344 Stock No.	Weight Each (kg)	Single Leg			Double Leg			Dimensions (mm)				Engineered Flat Size for S-1325A (mm)
(mm)	(in.)			Chain Size		WLL Based on Grade 8 Chain (t)*	Chain Size		WLL Based on Grade 8 Chain 0-45° Sling Angle (t)*	A	B	C	G	
				(mm)	(in.)		(mm)	(in.)						
12	7/16	1256862	.30	6	-	1.12	6	-	1.60	12.0	60.0	120	6.50	6
13	1/2	1256932	.36	7	1/4	1.50	-	-	-	-	-	-	-	-
17	11/16	1257002	.86	8	5/16	2.00	7	1/4	2.12	13.0	60.0	120	6.50	7-8
19	3/4	1257072	1.08	10	3/8	3.15	8	5/16	2.80	17.0	90.0	160	8.50	10
20	3/4	1257082	1.17	13	1/2	5.30	10	3/8	4.25	19.0	90.0	160	8.50	10
22	7/8	1257214	1.59	-	-	-	-	-	-	20.0	80.0	150	-	-
22	7/8	1257212	1.63	16	5/8	8.00	13	1/2	7.50	22.0	90.0	170	-	-
22	7/8	1257215	2.39	-	-	-	-	-	-	22.0	100	180	10.5	13
25	1	1257282	2.43	18	-	10.0	-	-	-	22.0	145	275	-	-
25	1	1257302	2.31	19	-	11.2	16	5/8	11.2	25.0	115	210	13.5	16
25	1	1257332	3.35	-	-	-	-	-	-	25.0	100	190	-	-
28	1-1/8	1257352	3.22	-	-	-	-	-	-	25.0	145	275	-	-
28	1-1/8	1257382	3.91	20	3/4	12.5	-	-	-	28.0	110	210	-	-
31	1-7/32	1257422	4.86	22	7/8	15.0	18	-	14.0	28.0	145	275	13.5	16
32	1-1/4	1257442	5.30	-	-	-	19	-	16.0	31.0	145	275	15.5	-
36	1-7/16	1257492	6.87	25	-	20.0	20	3/4	17.0	32.0	140	270	-	-
38	1-1/2	1257502	7.63	26	1	21.2	22	7/8	21.2	36.0	155	285	-	-
40	1-9/16	1257532	8.96	-	-	-	-	-	-	38.0	140	270	-	-
45	1-3/4	1257569	10.31	28	-	25.0	-	-	-	40.0	160	300	-	-
45	1-3/4	1257564	12.70	-	-	-	-	-	-	45.0	140	250	-	-
45	1-3/4	1257562	12.82	32	1-1/4	31.5	25	-	28.0	45.0	170	320	-	-
50	1-31/32	1257582	17.60	-	-	-	26	1	30.0	45.0	180	340	-	-
51	2	1257632	17.26	-	-	-	32	1-1/4	45.0	50.0	200	380	-	-
57	2-1/4	1257652	18.72	-	-	-	-	-	-	51.0	215	390	-	-
										57.0	203	406	-	-

\* Chain slings require that the Minimum Ultimate Load be 4 times the Working Load Limit. Refer to page 162 to determine products actual Ultimate Load. See chart on page 240 for other sling angles.  
\* There are no manufactured flats on links over 31mm (1 1/4).

## Welded Master Link Assembly with Engineered Flat



**A-347**  
Welded Master Link  
with Engineered Flat

**Ratings below are for use with chain slings fabricated in accordance with ASME B30.9. For other applications, see page 163.**

- Alloy Steel - Quenched and Tempered.
- Individually Proof Tested with certification. (See page 163 for proof test values.)
- Proof Tested with 60% inside width special fixtures sized to prevent localized point loading per ASTM A-952. Reference page 276.
- Meets or exceeds all requirements of ASME B30.26 including identification, ductility, design factor, proof load and temperature requirements. Importantly, these links meet other critical performance requirements including fatigue life, impact properties and material traceability, not addressed by ASME B30.26.
- Each link has a Product Identification Code (PIC) for material traceability, along with the size and the name Crosby® or “CG”.
- Large inside width and length to allow additional room for sling hardware and crane hook.
- Engineered flat for use with S-1325A coupler link.

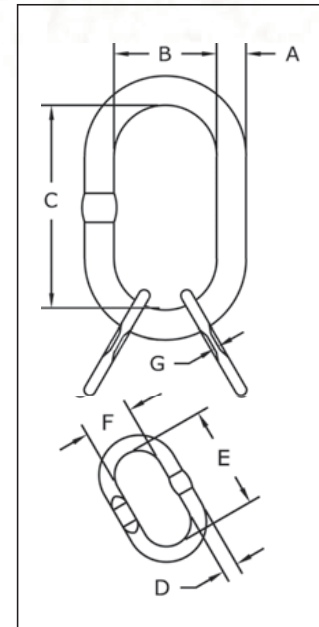

17/13 through 31/25 have Engineered Flat



### A-347 Welded Master Link Assembly with Engineered Flat

Size		A-347 Stock No.	Weight Each (kg.)	Three and Four Leg Sling		WLL Based on Grade 8 0-45° Sling Angle (t)*	Dimensions (mm)							Engineered Flat Size for S-1325 (mm)
(mm)	(in.)			Chain Size (mm)	(in.)		A	B	C	D	E	F	G	
13/12	1/2	1257692	.82	6	7/32	2.36	13.0	60.0	120	12.0	85.0	45.0	6.00	6
17/13	11/16	1257762	1.58	7	1/4	3.15	17.0	90.0	160	13.0	120	60.0	6.50	7
19/13	3/4	1257832	1.80	8	5/16	4.25	19.0	90.0	160	13.0	120	60.0	6.50	8
22/20		1257977	3.93				22.0	90.0	170	20.0	150	80.0	-	-
22/17	7/8	1257972	3.35	10	3.8	6.70	22.0	100	180	17.0	160	90.0	8.50	10
22/16		1257979	3.53				22.0	145	275	16.0	120	60.0	-	-
25/20		1258122	4.65				25.0	100	190	20.0	150	80.0	-	-
25/19		1258102	5.51				25.0	145	275	19.0	160	90.0	-	-
28/22		1258162	6.40				28.0	110	210	22.0	170	90.0	-	-
28/22	1-1/8	1258142	7.17	13	1/2	11.2	28.0	145	275	22.0	180	100	10.5	13
31/25	1-7/32	1258182	9.72	16	5.8	17.0	31.0	145	275	25.0	210	115	13.5	16
32/25		1258202	9.92				32.0	140	270	25.0	190	100	-	-
36/28		1258222	12.20				36.0	145	275	28.0	190	100	-	-
38/32		1258224	18.23				38.0	140	270	32.0	270	140	-	-
40/31	1-9/16	1258332	18.68	19	3.4	23.6	40.0	160	300	31.0	275	145	-	-
45/38		1258422	27.96				45.0	170	320	38.0	270	140	-	-
45/36	1-3/4	1258402	26.56	22	7/8	31.5	45.0	180	340	36.0	285	155	-	-
50/38		1258442	32.86				50.0	200	380	38.0	270	140	-	-
51/45	2	1258462	42.92	26	1	45.0	51.0	190	350	45.0	340	180	-	-
57/50		125482	59.70				57.0	203	406	50.0	380	200	-	-

\* Chain slings require that the Minimum Ultimate Load be 4 times the Working Load Limit. Refer to page 163 to determine products actual Ultimate Load. See chart on page 240 for other sling angles. \*\*There are no manufactured flats on links over 31mm (1 1/4).



# Grade 80 Latch Hooks



**S-314A**  
Clevis Chain Hook

- Hook is Forged Alloy Steel - Quenched and Tempered.
- Individually Proof Tested at 2-1/2 times the Working Load Limit with certification.
- Integrated heavy duty latch.
- Large throat opening.
- Anti-fouling due to carefully designed contours.
- Meets ASTM A-952 for Grade 80 chain fittings.
- Fatigue rated.
- “Look for the color Gold – Crosby Alloy Hooks.”

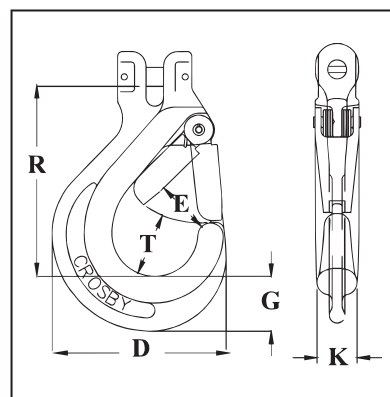

**Fatigue Rated**

## S-314A Clevis Chain Hook with Integrated Latch

Chain Size		S-314A Stock No.	Grade 8 Alloy Chain Working Load Limit (t) 4:1*	Weight Each (kg)	Dimensions (mm)						Replacement Latch Stock No.
(mm)	(in.)				D	E	G	K	R	T	
6	—	1225020	1.12	.32	66.0	20.6	20.0	16.0	72.3	26.0	1291332
7 - 8	1/4 - 5/16	1225021	2	.70	89.0	27.4	28.0	20.5	98.0	32.6	1291402
10	3/8	1225091	3.15	1.29	110.5	36.1	29.3	24.0	125.3	42.2	1291472
13	1/2	1225161	5.3	2.34	138.5	38.6	42.1	29.5	144.5	49.2	1291542
16	5/8	1225162	8	3.67	166.5	48.5	52.0	38.0	172.6	58.9	1291612

\* Ultimate Load is 4 times the Working Load Limit.



**S-315A**  
Eye Chain Hook

- Hook is Forged Alloy Steel - Quenched and Tempered.
- Individually Proof Tested at 2-1/2 times the Working Load Limit with certification.
- Crosby recommends grinding the WLL (which is 5:1 Design Factor) off the hook when using with Grade 80 chain.
- Integrated heavy duty latch.
- Large throat opening.
- Anti-fouling due to carefully designed contours.
- “Engineered Flat” for use with S-1325A Coupler Link.
- Meets ASTM A-952 for Grade 80 chain fittings.
- Fatigue rated.
- “Look for the color Gold – Crosby Alloy Hooks.”

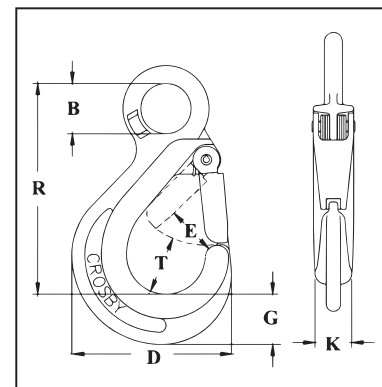

**Fatigue Rated**

## S-315A Eye Chain Hook with Integrated Latch

Chain Size		S-315A Stock No.	Grade 80 Alloy Chain Working Load Limit (t) 4:1*	Working Load Limit for Wire Rope (t) 5:1	Weight Each (kg)	Dimensions (mm)						Replacement Latch Stock No.	Engineered Flat Size for S-1325A (mm)	
(mm)	(in.)					B	D	E	G	K	R			T
6	—	1029820	1.12	1	.25	20.1	66.0	20.6	20.1	16.0	84.5	25.9	1291332	
7 - 8	1/4 - 5/16	1029825	2	2	.59	27.9	89.0	27.4	27.9	20.6	117	32.5	1291402	
10	3/8	1029830	3.15	3	1.18	36.1	110	36.1	29.5	23.9	157	42.2	1291472	
13	1/2	1029835	5.3	5	2.13	46.0	138	38.6	42.4	29.5	186	49.3	1291542	
16	5/8	1029840	8	7	3.88	56.0	167	48.5	52.0	38.1	227	59.0	1291612	

\* Ultimate Load is 4 times the Working Load Limit.

**CHAIN & ACCESSORIES**



**S-4320**  
Replacement Latch Kit

- Heavy duty stamped latch interlocks with the hook tip.
- High cycle, long life spring.
- Can be made into a "Positive Locking" Hook when proper cotter pin is utilized.
- Latch kits shipped unassembled and individually packaged with instructions.

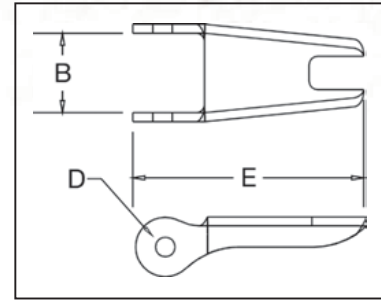

**IMPORTANT:** The new S-4320 Latch Kit will not fit the old style 319, 320 and 322 hooks.



**S-4320 Replacement Latch Kit for 319N (new), 320N, 322N and 339N Hooks**

Hook Size (t)			Hook ID Code	S-4320 Stock No.	SS-4320 Stock No.*	Weight Each (kg)	Dimensions (mm)		
Carbon	Alloy	Bronze					B	D	E
.75	1.25	.5	D	1096325	1097100	.01	12.7	3.80	36.6
1	1.6	.6	F	1096374	1097109	.02	13.7	4.30	39.6
1.6	2	1	G	1096421	1097118	.02	16.0	4.30	42.2
2	3.2	1.4	H	1096468	1097127	.03	16.8	4.30	48.5
3.2	5.4	2	I	1096515	1097136	.05	21.1	5.10	58.5
5	8	3.5	J	1096562	1097145	.07	26.4	5.10	73.2
7.5	11.5	5	K	1096609	1097154	.13	31.8	6.85	90.5
10	16	6.5	L	1096657	1097163	.15	34.3	6.85	97.0
15	22	10	N	1096704	1097172	.38	42.2	9.90	132

\* SS-4320 is Stainless Steel construction with cad plated steel nuts.



- To be used on A-327 and A-339 Grade 8 Sling Hooks.
- Latch Kits shipped unassembled and individually packaged with instructions.

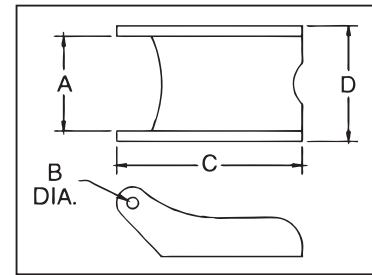

**S-4088 Alloy Hook Latch Kits**

Hook Chain Size (mm)	S-4088 Stock No.	Weight Each (kg)	Dimensions (mm)			
			A	B	D	D
6-7	1090250	.03	19.8	4.05	51.5	23.9
8-10	1090251	.06	26.2	4.85	68.5	31.8
13	1090252	.07	26.2	4.85	76.0	31.8
16	1090253	.07	26.2	4.85	82.5	31.8
19	1090254	.07	38.9	6.60	105	47.8
22	1090255	.07	38.9	6.60	118	51.0



- Latch Kits shipped unassembled and individually packaged with instructions.
- For use only with Crosby L-1338 and L-1358 Grab Hooks (page 233).

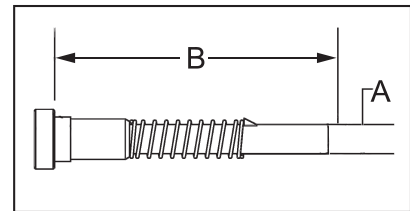

**S-4338 Grab Hook Latch Kits**

Hook Size		S-4338 Stock No.	Weight Each (kg)	Dimensions (mm)	
(mm)	(in.)			A	B
7	1/4	1048426	.01	4.7	40.4
8	5/16				
10	3/8	1048435	.01	4.7	45.2
13	1/2	1048444	.02	6.3	57.2
16	5/8	1048453	.03	7.9	65.2





## ENGINEERING SPECIFICATIONS



**Spectrum 3®**  
Chain

Crosby Proof Coil – Spectrum 3® Chain						
Trade Size (mm)	Size Material (mm)	Working Load Limit (t)	Maximum Inside Length (mm)	Minimum Inside Width (mm)	Maximum Length 100 Links (mm)	Weight per 30 Meters (kg)
5	5.50	.34	24.9	7.62	2489	17.7
7	7.00	.59	31.5	9.65	3150	29.5
8	8.00	.87	32.8	11.2	3277	45.4
10	10.0	1.21	35.1	14.0	3505	65
13	13.0	2.04	45.5	18.3	4547	113
16	16.0	3.13	55.9	20.1	5588	190
19	20.0	4.81	69.9	25.0	6985	294



**Spectrum 4®**  
Chain

Crosby High Test – Spectrum 4® Chain						
Trade Size (mm)	Size Material (mm)	Working Load Limit (t)	Maximum Inside Length (mm)	Minimum Inside Width (mm)	Maximum Length 100 Links (mm)	Weight per 30 Meters (kg)
7	7.00	1.18	31.5	9.65	3150	31.8
8	8.00	1.77	32.8	11.2	3277	48.1
10	10.0	2.45	35.1	14.0	3505	70
11	11.9	3.27	35.6	16.5	3560	93
13	13.0	4.18	45.5	18.3	4547	121
16	16.0	5.22	55.9	20.1	5588	182
19	20.0	7.35	70.1	24.9	7010	257



**Spectrum 7®**  
Chain

Crosby Transport – Spectrum 7® Chain						
Trade Size (mm)	Size Material (mm)	Working Load Limit (t)	Maximum Inside Length (mm)	Minimum Inside Width (mm)	Maximum Length 100 Links (mm)	Weight per 30 Meters (kg)
7	7.00	1.44	31.5	9.65	3150	36.7
8	8.70	2.14	33.5	12.2	3353	44.5
10	10.0	3.00	35.1	14.0	3505	64
11	11.9	3.98	41.7	16.5	4166	98
13	13.0	5.13	45.5	18.3	4547	112



## SPECTRUM 3® CHAIN



- Carbon Steel.
- Minimum Ultimate load is 4 times the Working Load Limit.
- Proof Tested at 2 times the Working Load Limit with certification.
- Permanently embossed with CG (Crosby Group) and 3 (Grade).
- Finish - Self colored and galvanized.
- Standard Container - fiber drum.

## SPECTRUM 3® Proof Coil Chain

Chain Size (mm)	Working Load Limit (t)*	Meters Per Drum	Weight Per 30 Meters (kg)	Drum Stock No. S.C.	Drum Stock No. Galv.
5	.36	244	17.7	275151	276150
6	.59	244	29.5	275259	276258
8	.86	168	45.4	275357	276356
10	1.20	122	65.5	275455	276454
13	2.04	61	113	275552	276551
16	3.13	46	191	275650	276659
19	4.81	30	294	275758	276757

\* Proof Loaded at 2 times the Working Load Limit.



**NOTE :** \* Spectrum 3® Proof Coil Chain is not recommended for overhead lifting. For these applications, Spectrum 8® or Spectrum 10® Alloy chain should be used. See pages 227 and 242.

# High Test Chain



## SPECTRUM 4® CHAIN



- Carbon Steel.
- Minimum Ultimate load is 3 times the Working Load Limit.
- Proof Tested at 1.5 times the Working Load Limit with certification.
- Permanently embossed with CG® (Crosby Group) and 7 (Grade).
- Finish - Self Colored
- Standard container - fiber drum.

## SPECTRUM 4® High Test Chain

Chain Size (mm)	Working Load Limit (t)*	Meters Per Drum	Weight Per 30 Meters (kg)	Drum Stock No. S.C.	1/2 Drum Stock No. S.C.
6	1.18	244	31.8	272788	272895
8	1.77	168	48.1	272797	272902
10	2.45	122	69.9	272804	272911
11	3.27	91	94.8	272813	272920
13	4.17	61	121	272822	272939
16	5.90	46	182	272831	272948
19	7.35	30	257	272840	272957

\* Proof Loaded at 1.5 times the Working Load Limit.



**NOTE :** \* Spectrum 4® High Test Transport chain is not recommended for overhead lifting. For these applications, Spectrum 8® or Spectrum 10® Alloy chain should be used. See pages 227 and 242.

## SPECTRUM 7® CHAIN



- High Tensile Carbon Steel.
- Minimum Ultimate load is 4 times the Working Load Limit.
- Proof Tested at 2 times the Working Load Limit with certification.
- Permanently embossed with CG® (Crosby Group) and 7 (Grade).
- Finish - Yellow Dichromate.
- Standard container - fiber drum.

## SPECTRUM 7® High Tensile Transport Chain

Chain Size (mm)	Working Load Limit (t)*	Meters Per Drum	Weight Per 30 Meters (kg)	Drum Stock No.	1/2 Drum Stock No.
6	1.43	244	36.7	273153	273260
8	2.13	168	44.5	273162	273279
10	3.00	122	64.0	273171	273288
11	3.97	91	98.0	273180	273297
13	5.13	61	112	273199	273304

\* Proof Loaded at 2 times the Working Load Limit.



**NOTE :** \* Spectrum 7® High Test Transport chain is not recommended for overhead lifting. For these applications, Spectrum 8® or Spectrum 10® Alloy chain should be used. See pages 227 and 242.



# Crosby® Connecting Links



**A-336**  
Connecting Link

- Forged Alloy Steel - Quenched and Tempered.
- Individually Proof Tested at 2-1/2 times the Working Load Limit with certification.
- Easy to assemble - see instructions on page 276.

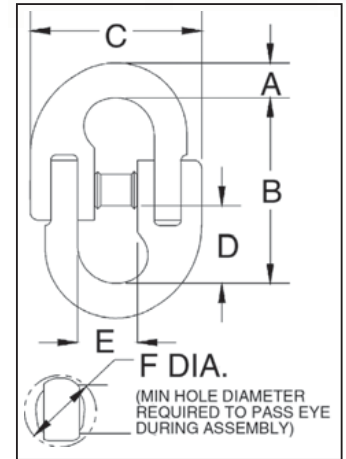

## A-336 LOK-A-LOY® 6 Connecting Link

Chain Size (mm)	A-336 Stock No.	Working Load Limit (t)*	Weight Each (kg)	Dimensions (mm)					Diameter of Hole to Accept Link (mm)
				A	B	C	D	E	
6-7	1014397	1.47	.11	7.85	52.5	42.9	19.8	19.8	12.7
8-10	1014413	3.00	.27	11.4	69.0	58.5	26.9	27.7	16.8
13	1014431	5.10	.54	14.7	85.0	80.5	32.5	35.8	22.4
16	1014459	7.48	1.10	19.8	99.5	100	39.6	42.9	26.9
19	1014477	10.45	1.76	22.6	123	113	50.0	51.0	30.2
22	1014495	13.04	2.75	25.4	148	135	60.5	64.0	35.1
26	1014510	17.58	3.19	27.4	165	154	72.0	65.0	37.3
32	1014538	26.00	6.00	35.1	215	194	96.0	96.0	44.0

\* Ultimate Load is 4 times the Working Load Limit.

The WLL of the A-336 are less than Grade 80 chain ratings. When using in Grade 80 chain slings, ANSI B30.9c requires that the Working Load Limit of a sling must not exceed the lowest Working Load Limit of the components in the system.



**G-334 / S-334**  
Replacement Link

- Forged Steel - Quenched and Tempered.
- Has larger inside dimensions making it easier to attach hooks or other fittings to the chain.
- An exclusive Crosby product.
- After making connections, rivets must be peened.

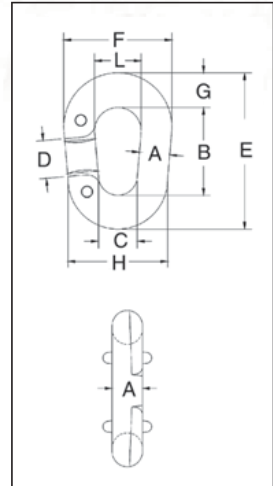

**G-334/S-334 Pear Shape “Missing Link”® Replacement Links**

Chain Size (mm)	Stock No.		Working Load Limit (t)*	Weight Per 100 (kg)	Dimensions (mm)								
	G-334 Galv.	S-334 S.C.			A	B	C	D	E	F	G	H	L
10	1013432	1013441	.84	11.3	10.4	51.0	14.2	20.6	74.5	41.4	11.9	35.1	20.6
13	1013450	1013469	1.50	22.7	12.7	63.5	17.5	25.4	92.0	51.0	14.2	42.9	25.4
16	1013478	1013487	2.27	34.0	16.0	70.0	20.6	26.9	102	60.5	16.0	52.5	28.7
19	1013496	1013502	3.22	56.7	19.1	79.5	25.4	28.7	121	70.0	20.6	63.5	31.8
22	1013511	1013520	4.35	90.7	22.4	93.5	31.8	35.1	141	82.5	23.9	76.0	38.1

\* Ultimate Load is 4 times the Working Load Limit.

Not Suitable for use with Grade 80 or Grade 100 chain and chain slings used in overhead lifting.



**G-335 / S-335**  
Replacement Link

- Forged Steel - Quenched and Tempered.
- Integral rivets join the two halves.
- After making connections, rivets must be peened.

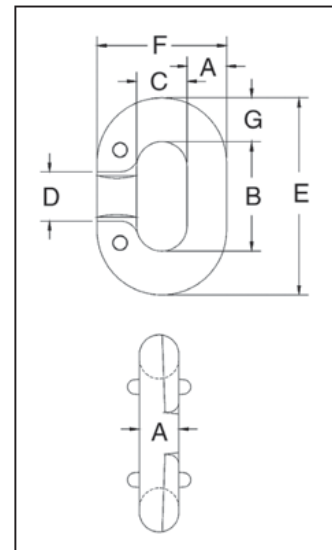

Meets or exceeds the performance requirements of Federal Specifications RRC-27ID, Type II, except for those provisions required of the contractor. For additional information, see page 476.

**G-335/S-335 “Missing Link”® Replacement Links**

Chain Size (mm)	Stock No.		Working Load Limit (t)*	Links Per Box	Weight Per 100 (kg)	Dimensions (mm)						
	G-335 Galv.	S-335 S.C.				A	B	C	D	E	F	G
** 5	1013094	1013101	.36	20	1.13	6.35	17.5	8.65	8.65	30.2	19.8	7.10
** 7	1013110	1013129	.60	10	2.83	7.10	22.4	11.2	11.2	38.1	25.4	7.85
** 8	1013138	1013147	.89	10	5.67	8.65	23.9	11.9	11.9	42.9	29.5	9.65
10	1013156	1013165	1.25	10	9.07	10.4	28.7	14.2	14.2	52.5	35.1	11.9
11	1013174	1013183	1.65	10	12.5	11.9	32.5	15.0	15.0	59.5	38.9	13.5
13	1013192	1013209	2.15	10	17.0	13.5	37.3	16.8	16.8	67.5	43.7	15.0
16	1013236	1013245	3.30	10	32.9	16.8	46.0	19.8	20.6	84.0	53.0	19.1
19	1013254	1013263	4.65	10	55.5	19.8	54.0	23.9	26.9	98.5	63.5	22.4
22	1013272	1013281	5.45	Bulk	79.5	23.1	63.5	28.7	28.7	114	74.5	25.4
† 26	1013290	1013307	7.00	Bulk	113	26.2	70.0	31.8	31.8	127	84.0	28.7

\* Ultimate Load is 4 times the Working Load Limit. \*\* Rivets Only - No interlocking lugs. † Has reinforced rivet holes. All sizes have countersunk rivet holes.

Not Suitable for use with Grade 80 or Grade 100 chain and chain slings used in overhead lifting.

# Crosby® Connecting Links



**S-247**  
Double Clevis Link

- All pins Alloy Steel - Quenched and Tempered.
- Body is forged and heat treated carbon steel.
- Designed for linking all popular sizes of Crosby Spectrum 3® and Spectrum 4® chain to rings, end links, eye hooks, pad eyes, tractor eye bolts, etc.
- Features quick and easy assembly.

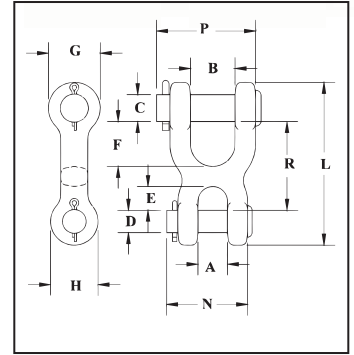

## S-247 Double Clevis Link

Chain Size (mm)	S-247 Stock No.	Working Load Limit (t)*	Weight Each (kg)	Dimensions (mm)											
				A	B	C	D	E	F	G	H	L	N	P	R
7	1013021	1.18	.17	12.7	19.1	12.7	7.85	9.65	19.1	25.4	20.6	71.5	35.1	42.2	38.1
8-10	1013049	2.45	.37	14.2	25.4	16.0	11.2	11.9	25.4	30.2	25.4	89.5	44.5	57.0	48.5
11	1013067	3.27	.57	17.5	28.7	17.5	14.2	15.0	27.7	33.3	30.2	103	51.0	63.5	55.5
13	1013085	4.17	.71	20.6	31.8	19.1	16.0	17.3	31.8	36.6	33.3	115	57.0	70.0	62.5

\* Ultimate Load is 4 times the Working Load Limit.

Not Suitable for use with Grade 80 or Grade 100 chain and chain slings used in overhead lifting.



**S-249**  
Twin Clevis Link

- Available in three popular sizes.
- Body is forged and heat treated carbon steel.
- All pins Alloy Steel - Quenched and Tempered.
- Features quick and easy assembly.
- Twin Clevis design provides a variety of uses and can be used with Crosby Spectrum 3®, Spectrum 4® and Spectrum 7® chain.

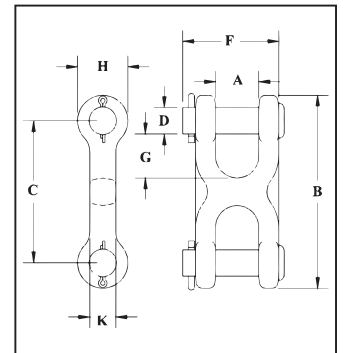

## S-249 Twin Clevis Link

Chain Size (mm)	S-249 Stock No.	Working Load Limit (t)*	Weight Each (kg)	Dimensions (mm)							
				A	B	C	D	F	G	H	K
7-8	1012861	2.13	.14	11.9	63.5	39.6	9.65	33.3	10.9	23.9	12.7
10	1012889	3.00	.20	13.5	71.5	46.0	11.2	38.9	12.7	25.4	14.2
11-13	1012905	5.10	.44	16.5	92.0	58.5	14.2	48.5	16.0	33.3	20.6

\* Ultimate Load is 4 times the Working Load Limit.

Not Suitable for use with Grade 80 or Grade 100 chain and chain slings used in overhead lifting.





**H-330 / A-330**  
Clevis Grab Hook

- Forged Steel - Quenched and Tempered.
- Design factor is 4:1.
- Features quick and easy assembly.
- H-330 designed for Crosby Spectrum 4® chain.
- A-330 designed for Crosby Spectrum 7® chain.

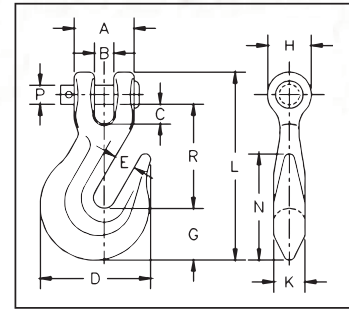

**H-330 / A-330 Clevis Grab Hooks**

Chain Size (mm)	Stock No.		Working Load Limit (t)		Weight Each (kg)	Dimensions (mm)											
	H-330 Carbon	A-330 Alloy*	H-330 Carbon	A-330 Alloy		A	B	C	D	E	G	H	K	L	N	P	R
7	1027105	1027249*	1.18	1.59	.16	25.4	8.15	7.85	46.0	8.65	22.4	18.3	11.9	77.5	44.5	7.85	41.7
8	1027123	1027267*	1.77	2.04	.29	30.2	9.90	9.15	54.0	11.2	24.6	23.1	15.0	93.0	52.5	9.65	61.5
10	1027141	1027285*	2.45	3.22	.45	35.1	11.4	11.4	64.5	12.7	29.7	25.4	18.3	109	59.5	11.2	61.0
11	1027169	1027301	3.27	4.54	.59	42.2	16.8	15.7	78.5	14.2	33.3	28.7	17.5	125	67.5	14.2	70.0
13	1027187	1027329*	4.17	5.44	.95	47.8	14.5	17.8	90.5	16.8	38.9	31.8	19.8	145	75.5	16.0	81.0
16	1027203	1027347	5.90	8.2	1.91	58.0	23.1	21.3	112	19.8	45.2	39.6	27.7	179	109	19.1	104
19	1027221	1027365	9.16	11.2	2.95	66.5	23.9	23.9	133	23.9	54.0	47.8	33.3	207	129	22.4	118

\* These A-330 hooks are forged with an "8" designating Grade 80, and are suitable for use with Grade 8 chain in overhead lifting applications as long as hook is proof-tested as part of the chain sling assembly or as an individual component per ASME B30.9. We recommend the use of the A-338 which is proof tested and supplied with a proof test certificate.



**H-323 / A-323**  
Eye Grab Hook

- Forged Steel - Quenched and Tempered.
- Design Factor is 4:1.
- H-323 designed for Crosby Spectrum 4® chain.
- A-323 designed for Crosby Spectrum 7® chain.

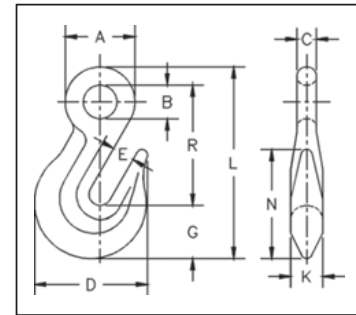

**H-323 / A-323 Eye Grab Hooks**

Chain Size (mm)	Stock No.		Working Load Limit (t)		Weight Each (kg)	Dimensions (mm)											
	H-323 Carbon	A-323 Alloy*	H-323 Carbon	A-323 Alloy		A	B	C	D	E	G	K	L	N	R		
7	1026204	1026384*	1.18	1.59	.13	27.7	13.5	7.85	46.0	8.65	22.4	11.9	77.5	44.5	47.8		
8	1026222	1026400*	1.77	2.04	.20	33.3	15.7	9.65	54.0	11.2	24.6	15.0	91.0	52.5	58.0		
10	1026240	1026428*	2.45	3.22	.36	39.6	19.1	11.2	64.5	12.7	29.7	18.3	109	59.5	68.5		
13	1026286	1026464*	4.17	5.44	.79	49.3	22.4	13.5	90.5	16.8	38.9	19.5	138	75.5	86.0		
16	1026302	1026482*	5.90	8.21	1.47	60.5	26.9	16.8	112	19.8	48.0	25.4	169	96.0	104		
19	1026320	1026507	9.16	11.2	2.69	73.0	35.1	19.1	133	23.9	54.0	33.3	205	129	131		

\* These A-330 hooks are forged with an "8" designating Grade 80, and are suitable for use with Grade 8 chain in over head lifting applications as long as hook is proof-tested as part of the chain sling assembly or as an individual component per ASME B30.9. We recommend the use of the A-338 which is proof tested and supplied with a proof test certificate.



**BL-GRB**  
Grab Hook with Latch

**Bullard Alloy Grab Hook with Latch**

- Dimensions shown relate to H-323 / A-323 drawing scheme shown above.

Chain Size (mm)	BL-GRB Stock No.	Working Load Limit (t)*	Weight Each (kg)	Dimensions (mm)											
				A	B	C	D	E	G	K	L	N	R		
7	1051904	1.60	.23	31.8	14.2	7.11	62.7	10.2	21.8	13.5	93.5	55.4	63.5		

\* Ultimate Load is 4 times the Working Load Limit.

# Crosby® Slip Hooks



**H-331 / A-331**  
Clevis Slip Hook

- Forged Carbon Steel or Forged Alloy Steel – Quenched and Tempered.
- All pins are Alloy Steel – Quenched and Tempered.
- Not suitable for use with Grade 80 chain and chain slings used in overhead lifting. For slings or lifting chains, Grade 80 or 100 alloy components are recommended.

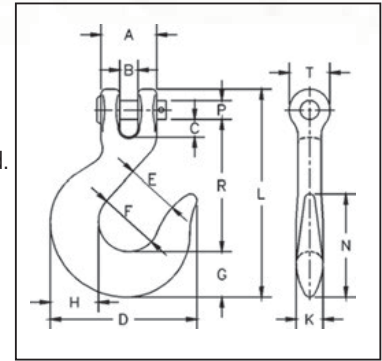

## H-331 / A-331 Clevis Slip Hooks

Chain Size (mm)	Stock No.		Working Load Limit (t)*		Weight Each (kg)	Dimensions (mm)													
	H-331 Carbon	A-331 Alloy	H-331 Carbon	A-331 Alloy		A	B	C	D	E	F	G	H	K	L	N	P	R	T
7	1027383	1027524	.89	1.25	.25	26.9	8.15	7.35	70.0	23.9	30.2	20.6	22.4	12.7	100	54.0	7.87	65.5	18.3
8	1027409	1027542	1.30	1.95	.36	31.0	10.9	8.65	77.5	26.9	31.8	23.9	25.4	14.2	115	57.0	9.65	73.0	24.6
10	1027427	1027560	1.81	2.38	.55	35.1	11.4	11.2	92.0	33.3	38.1	28.7	30.2	16.8	131	65.0	11.2	82.5	26.9
11	1027445	1027588	2.27	3.18	.93	43.9	15.0	15.2	110	39.6	46.0	35.1	36.6	20.6	152	77.5	14.2	94.0	30.2
13	1027463	1027604	2.95	4.08	1.25	47.8	14.5	13.5	122	42.9	49.3	39.6	41.4	23.1	166	87.5	16.0	102	33.3
16	1027481	1027622	4.20	6.12	2.15	58.5	18.0	18.0	143	51.0	60.5	46.0	49.3	27.7	200	102	19.1	125	39.6
19	—	1027640	— refriger- erator	8.73	5.12	81.0	30.0	32.8	187	63.5	76.2	60.5	63.5	36.6	255	129	25.4	155	53.0

\* Ultimate Load is 4 times the Working Load Limit.



**H-324**  
Eye Slip Hook

- Forged Carbon Steel – Quenched and Tempered.
- Not suitable for use with Grade 80 chain and chain slings used in overhead lifting. For slings or lifting chains, Grade 80 or 100 alloy components are recommended.

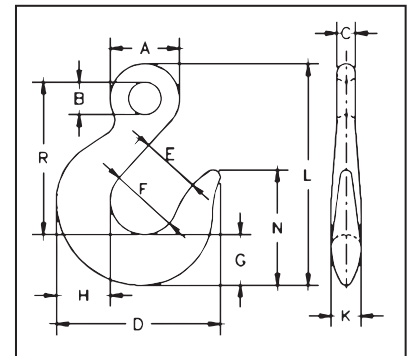

## H-324 Eye Slip Hooks

Chain Size (mm)	H-324 Stock No.	Working Load Limit (t)*	Weight Each (kg)	Dimensions (mm)											
				A	B	C	D	E	F	G	H	K	L	N	R
7	1026749	.89	.18	26.9	12.7	7.10	70.0	23.9	30.2	20.6	22.4	12.7	93.0	54.0	65.0
8	1026767	1.30	.29	31.8	16.0	8.65	77.5	26.9	31.8	23.9	25.4	14.2	107	57.0	75.0
10	1026785	1.81	.50	38.9	18.3	10.4	92.0	33.3	38.1	28.7	30.2	16.8	124	65.0	85.5
11	1026801	2.27	.71	42.9	20.6	11.2	110.2	39.6	46.0	35.1	36.6	20.6	145	77.5	98.5
13	1026829	2.95	.95	49.3	23.9	12.7	122.2	42.9	49.3	39.6	41.4	23.1	161	87.5	109
16	1026847	4.20	1.77	60.5	28.7	16.0	143.0	51.0	60.5	46.0	49.3	27.7	195	102	133
19	1026865	5.67	3.14	73.0	35.1	19.1	171.5	54.0	70.0	55.5	58.5	33.3	222	121	147

\* Ultimate Load is 4 times the Working Load Limit.

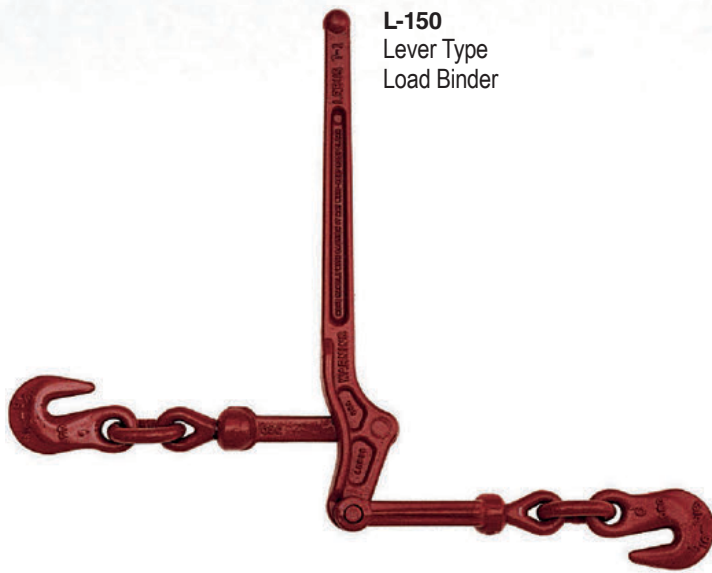

**L-150**  
Lever Type  
Load Binder

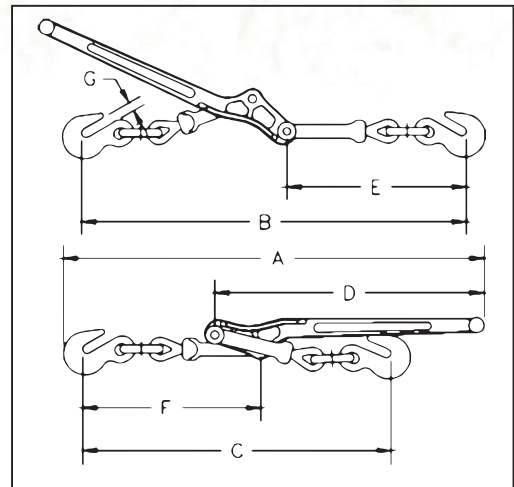

- Extra heavy construction at leverage point to prevent spreading. Heel of binder toggles away from load, permitting easy release.
- Ball and socket swivel joints at hook assemblies permit a straight line pull.
- Binders shown with Proof Loads have been individually proof tested to values shown, prior to shipment.
- Meets or exceeds requirements of US DOT FMCSA Part 393 Subpart I.

Load Rated



**L-150 Standard Lever Type Load Binders**

Model	Stock No.	Std. Pkg.	Min-Max Chain Size (mm)	Working Load Limit (t)	Proof Load (kN)	Ultimate Load (t)	Weight Each (kg)	Handle Length (mm)	Take Up (mm)	Dimensions (mm)						
										A	B	C	D	E	F	G
7-1	1048128	4	8 - 10	2.45	48	8.63	3.18	406	114	613	562	454	406	264	264	12.7
A-1	1048146	4	10 - 13	4.17	82	15.0	5.66	475	114	730	654	540	475	313	314	16.0
C-1	1048164	4	13 - 16	5.90	116	20.9	8.93	533	121	794	756	635	533	372	349	18.3



# Lebus® Load Binders



**L-140**  
Ratchet Type  
Load Binder

- Upgraded for use with Grades 70, 80 and 100 Chain.
- Utilizes standard Crosby A-323 Alloy Eye Grab Hooks.
- New design “one piece” forged handle.
- Continuous take-up feature provides finite adjustment to tie down load.
- One piece assembly, no bolts or nuts to loosen.
- Ratchet spring is rust proofed.
- All load bearing or holding parts forged.
- Easy operating positive ratchet.
- Binders shown with Proof Loads have been individually proof tested to values shown, prior to shipment.
- Meets or exceeds requirements of US DOT FMCSA Part 393 Subpart I.

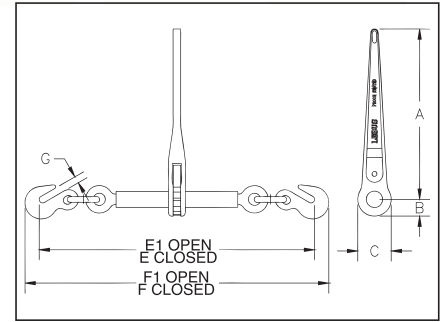

**SEE APPLICATION AND WARNING INFORMATION**  
On Pages 271  
Para Español: [www.thecrosbygroup.com](http://www.thecrosbygroup.com)

**Load Rated®**

## L-140 Standard Ratchet Type Load Binders

Model	Stock No.	Min-Max Chain Size (mm)	Working Load Limit (t)*	Proof Load (kN)	Weight Each (kg)	Handle Length (mm)	Barrel Length (mm)	Take Up (mm)	Dimensions (mm)							
									A	B	C	E	E1	F	F1	G
R-7 **	1048404	8 - 10	4.00	79	5.49	356	254	203	356	35.1	70.0	583	786	638	842	12.7
R-A **	1048422	10 - 13	6.80	134	6.66	356	254	203	356	35.1	70.0	641	845	702	905	16.0
R-C ***	1048440	13 - 16	7.26	143	6.60	356	254	203	356	35.1	70.0	670	873	748	951	18.3

\* Ultimate Load is 3 times the Working Load Limit. \*\* Matches the Working Load Limit of Grade 100 chain for both sizes. \*\*\* Matches the Working Load Limit of Grade 100 chain for 13mm size.

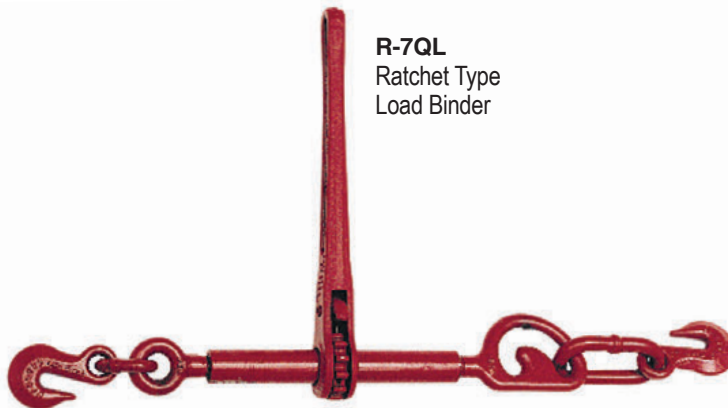

**R-7QL**  
Ratchet Type  
Load Binder

- For use with Grade 7 Transport Chain.
- Utilizes standard Crosby A-323 Alloy Eye Grab Hooks.
- New design “one piece” forged handle.
- Continuous take-up feature, infinite adjustment, gets the last half of chain.
- One piece assembly, no bolts or nuts to loosen.
- Ratchet spring is rust proofed.
- All load bearings or holding parts forged.
- Easy operating positive ratchet.
- Binders shown with Proof Loads have been individually proof tested to values shown, prior to shipment.

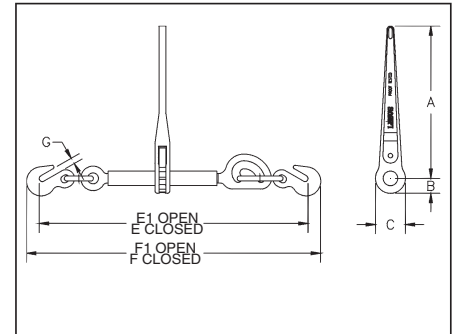

**Load Rated®**

## R-7QL QUIC-LINK Ratchet Load Binder

Model	Stock No.	Min-Max Chain Size (mm)	Working Load Limit (t)*	Proof Load (kN)	Weight Each (kg)	Handle Length (mm)	Barrel Length (mm)	Take Up (mm)	Dimensions (mm)							
									A	B	C	E	E1	F	F1	G
R-7QL	1048413	8 - 10	3.00	59	5.56	356	254	203	356	35.1	70.0	630	833	686	889	12.7

\* Ultimate Load is 3 times the Working Load Limit.

**CHAIN & ACCESSORIES**

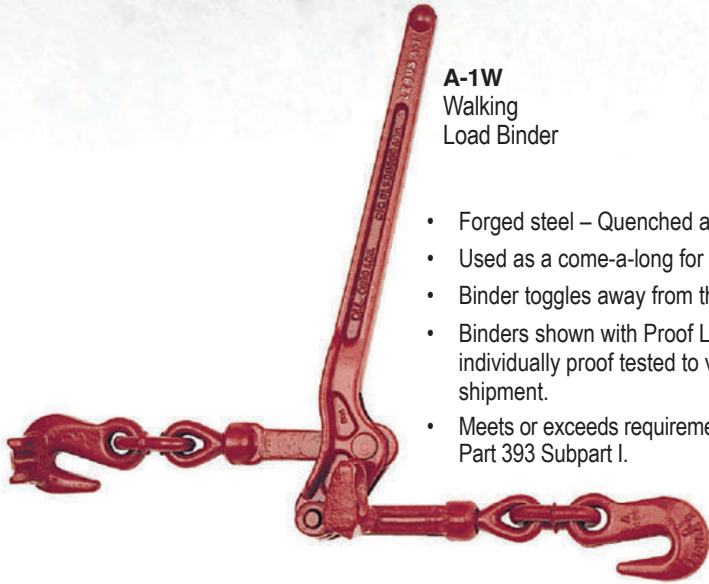

- Forged steel – Quenched and Tempered.
- Used as a come-a-long for short take-up on chain.
- Binder toggles away from the load.
- Binders shown with Proof Loads have been individually proof tested to values shown, prior to shipment.
- Meets or exceeds requirements of US DOT FMCSA Part 393 Subpart I.

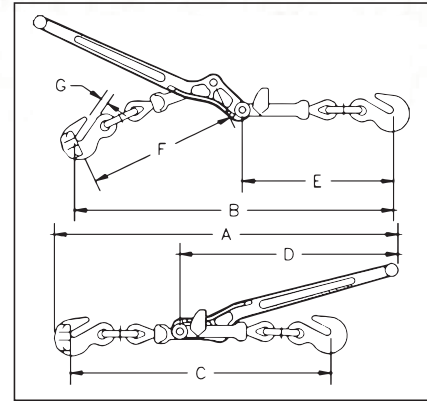

**SEE APPLICATION AND WARNING INFORMATION**  
On Pages 271  
Para Español: [www.thecrosbygroup.com](http://www.thecrosbygroup.com)



Load Rated®

A-1W Walking Load Binders

Model	Stock No.	Chain Size (mm)	Working Load Limit (t)	Proof Load (kN)	Ultimate Load (t)	Weight Each (kg)	Handle Length (mm)	Dimensions (mm)						
								A	B	C	D	E	F	G
A-1W	1048388	13 only	4.17	82	15.0	5.94	475	730	654	540	475	313	314	16.0

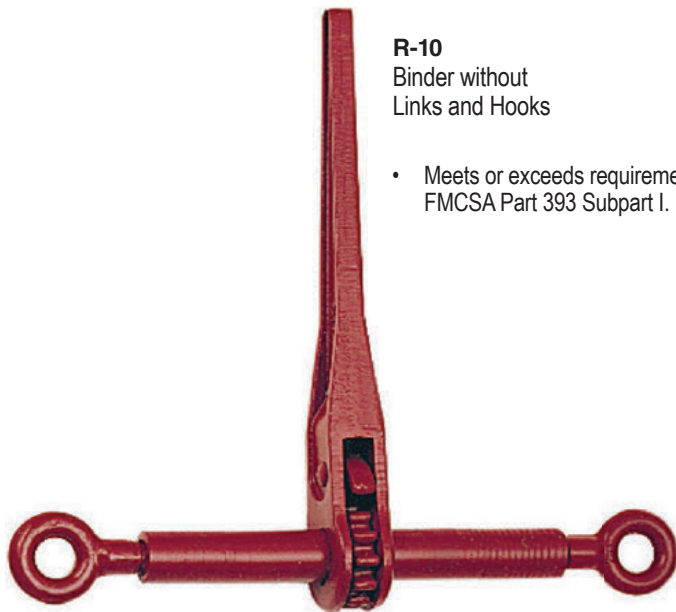

- Meets or exceeds requirements of US DOT FMCSA Part 393 Subpart I.

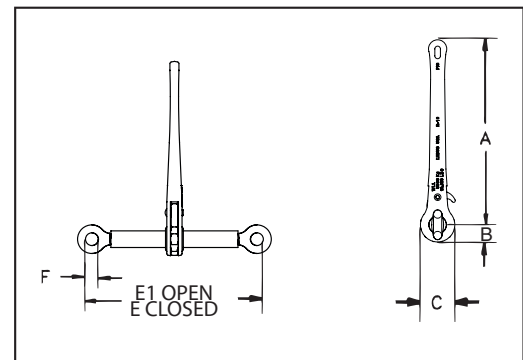

R-10 Binder without Links and Hooks

Model	Stock No.	Working Load Limit (t)*	Weight Each (kg)	Handle Length (mm)	Barrel Length (mm)	Take Up (mm)	Dimensions (mm)					
							A	B	C	E	E1	F
R-10	1048468	7.26	3.65	356	254	203	356	35.1	70.0	356	559	25.4

\* Ultimate Load is 3 times the Working Load Limit.

# Lebus® Load Binders

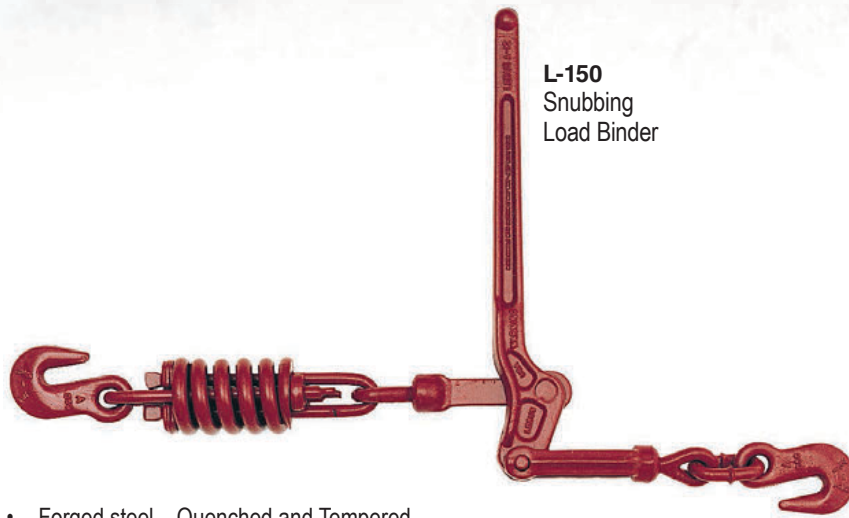

**L-150**  
Snubbing  
Load Binder

- Forged steel – Quenched and Tempered.
- Spring cushion for load protection, cushions shock and sway.
- Binder toggles away from the load.

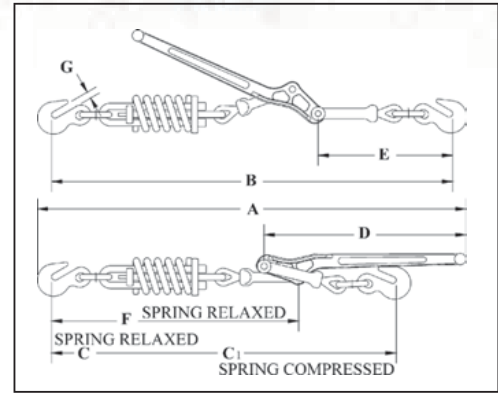

**SEE APPLICATION AND WARNING INFORMATION**  
On Pages 271  
Para Español: [www.thecrosbygroup.com](http://www.thecrosbygroup.com)



## L-150 Snubbing Load Binders

Model	Stock No.	Min-Max Chain Size (mm)	Working Load Limit (t)	Ultimate Load (t)	Weight Each (kg)	Handle Length (mm)	Take Up (mm)	Compression Strength of Spring (kg)	Dimensions (mm)							
									A	B	C	C1	D	E	F	G
7-12	1048280	8 - 10	2.45	7.27	5.10	406	108	1040	832	781	711	673	406	264	483	12.7
A-12	1048306	10 - 13	4.17	9.09	8.48	470	114	1500	945	864	749	773	475	313	530	16.0

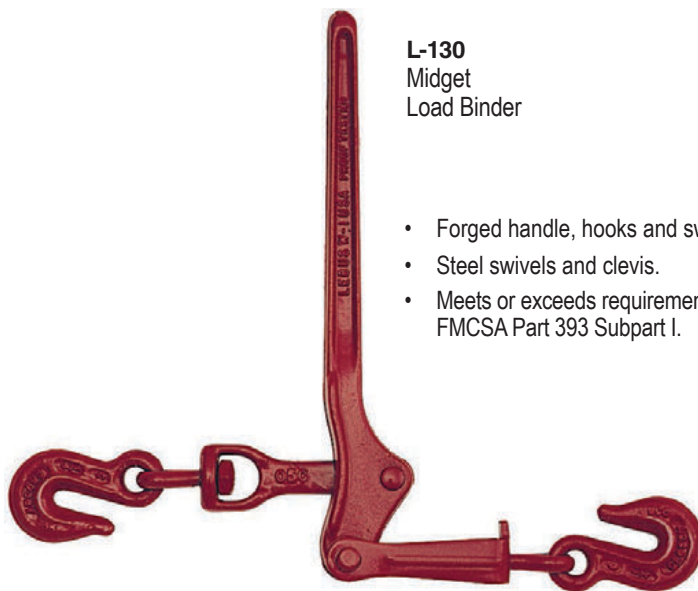

**L-130**  
Midget  
Load Binder

- Forged handle, hooks and swivel link.
- Steel swivels and clevis.
- Meets or exceeds requirements of US DOT FMCSA Part 393 Subpart I.

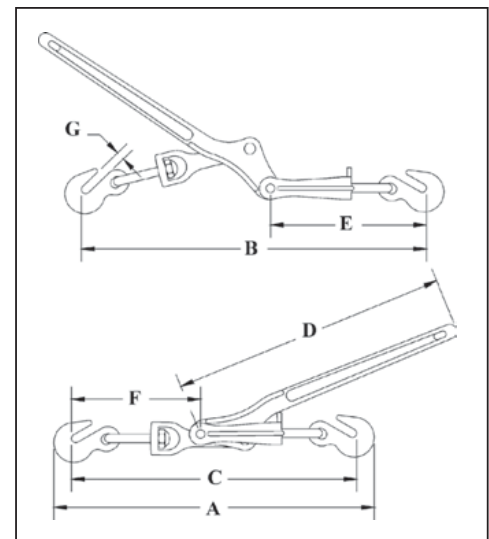

## L-130 Midget Load Binders

Model	L-130 Stock No.	Min-Max Chain Size (mm)	Working Load Limit (t)	Ultimate Load (t)	Weight Each (kg)	Take Up (mm)	Dimensions (mm)						
							A	B	C	D	E	F	G
W-1	1048100	5 - 6	.66	2.31	1.17	61.0	410	346	279	286	159	167	8.65



## Boomer and Tail Chains



**C-186 Spectrum 4®**  
High Test Boomer Chain

- Ends fitted with Crosby H-330 Quenched and Tempered carbon steel clevis grab hook.
- Finish – Self Colored.
- Meets or exceeds requirements of US DOT FMCSA Part 393 Subpart I.

### C-186 Spectrum 4® High Test Boomer Chains

Chain Size (mm)	C-186 Stock No.	Working Load Limit (kg)	Standard Length (m)	Weight Each (kg)
6	278988	1180	6.10	7.3
8	278997	1770	6.10	11.3
10	279004	2450	6.10	15.4
11	279013	3270	6.10	20.4
13	279022	4170	6.10	27.2
16	279031	5900	6.10	40.8



**C-187 Spectrum 7®**  
Transport Boomer Chain

- Ends fitted with Crosby H-330 Quenched and Tempered carbon steel clevis grab hook.
- Finish – Self Colored.
- Meets or exceeds requirements of US DOT FMCSA Part 393 Subpart I.

### C-187 Spectrum 7® Transport Boomer Chains

Chain Size (mm)	C-187 Stock No.	Working Load Limit (kg)	Standard Length (m)	Weight Each (kg)
6	279576	1430	6.10	7.3
8	279585	2130	6.10	11.3
10	279594	3000	6.10	15.4
11	279601	3970	6.10	20.4
13	279610	5130	6.10	27.2
5/8	279031	13000	20	90



**C-188 Spectrum 8®**  
Alloy Boomer Chain

- Heat treated alloy steel.
- Ends fitted with Crosby A-330 Quenched and Tempered alloy clevis grab hook.
- Finish – Self Colored.
- Meets or exceeds requirements of US DOT FMCSA Part 393 Subpart I.

### C-188 Spectrum 8® Alloy Boomer Chains

Chain Size (mm)	C-188 Stock No.	Working Load Limit (kg)	Standard Length (mm)	Weight Each (kg)
10	279889	3200	6.10	13.7
13	279898	5400	6.10	24.5



**L-180**  
Winchline Tail Chain

- Hooks are Forged – Quenched and Tempered.
- Individually Proof Tested.
- Spectrum 4® High Test Carbon Steel from 5/16" through 5/8" (8 - 16mm).
- Spectrum 8® Alloy Steel from 3/4" through 1-1/4" (20 - 32mm).
- Meets or exceeds requirements of US DOT FMCSA Part 393 Subpart I.

### L-180 Winchline Tail Chain

Wire Rope Diameter (mm)*	L-180 Stock No.	Working Load Limit (kg)†	Length (mm)	No. of Links	Weight Each (kg)
8 - 10	1091473	2450	457	11	1.36
13 - 16	1091482	5900	457	7	2.81
19 - 22	1091511	15510	610	8	8.25
25 - 29	1091516	21640	457	5	9.60
25 - 29	1091525	21640	610	7	10.6
32	1091532	32795	610	5	18.1

\* Recommended for IPS or XIP (EIP), RRL, FC or IWRC wire rope. † Ultimate Load is 3.5 times the Working Load Limit.

# Replacement Hooks for Chain Hoists



**O-318**  
Chain Nest Hook

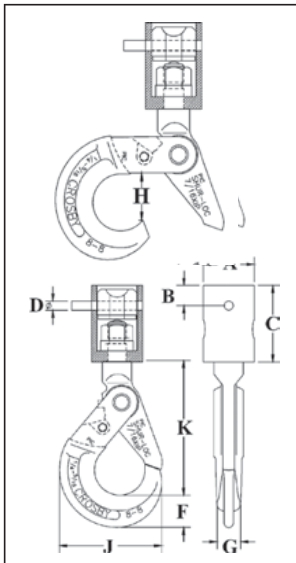

- Available in Working Load Limits of 1.7, 2.3, and 4.2 Tons.
- Fits 1/4" thru 9/16" hoist chain.
- Hooks are forged alloy steel – Quenched and Tempered.
- Chain connecting pin is alloy.
- A Product Identification Code (PIC) for material traceability, the size, and the name Crosby or "CG" are forged or stamped onto each hook and swivel assembly (chain nest).
- Entire assembly is zinc plated.
- Fitted with ball bearings and is suitable for frequent rotation under load.
- Repair kit available consisting of bearing and spring pin.
- O-318 Hooks utilize Crosby SHUR-LOC® "Positive Locking" hooks. Latch is Self-Locking when hook is loaded.
- O-319 Hooks utilize Crosby® standard 319 Shank Hooks with the registered **QUIC-CHECK®** marking.
- Replacement latch kits are available.
- Use in corrosive environment requires shank and nut inspection in accordance with ASME B30.10-1.10.4(b)(5)(c)2009.



**O-319**  
Chain Nest Hook

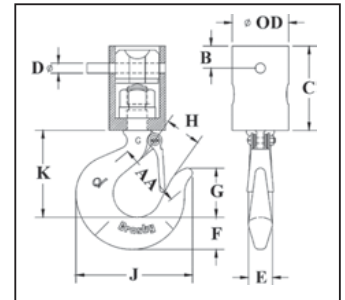

**SEE APPLICATION AND WARNING INFORMATION**  
 0-318 On Pages 272-273  
 0-319 On Pages 146-147  
 Para Español: [www.thecrosbygroup.com](http://www.thecrosbygroup.com)

## O-318 Chain Nest Hooks

Chain Size (mm)	O-318 Stock No.	Working Load Limit (t)*	Weight Each (kg)	Dimensions (mm)								
				A	B	C	D	F	G	H	J	K
6 - 7	1098409	1.5	1.59	44.5	17.8	66.5	7.87	27.9	20.6	37.1	89.0	117
8 - 10	1098427	2.1	2.72	54.0	17.8	81.0	9.65	29.2	23.9	46.5	110	144
10 - 11	1098445	3.8	6.24	76.0	25.4	111	12.7	42.2	29.5	53.5	138	179
13 - 14	1098463	3.8	6.24	76.0	25.4	111	16.0	42.2	29.5	53.5	138	179

\* Ultimate Load is 4 times the Working Load Limit.

## O-319 Chain Nest Hooks

Chain Size (mm)	O-319 Stock No.	Working Load Limit (t)*	Weight Each (kg)	Dimensions (mm)										
				OD	AA	B	C	D	E	F	G	H	J	K
6 - 7	1098312	1.5	1.16	44.5	51.0	17.8	66.5	7.87	19.1	25.4	38.9	25.4	92.0	68.5
8 - 10	1098334	2.1	1.81	54.0	51.0	17.8	81.0	9.65	21.3	28.4	43.7	28.4	104	77.5
10 - 11	1098356	3.8	4.54	76.0	63.5	25.4	111	12.7	28.4	36.6	54.0	34.0	123	96.0
13 - 14	1098378	3.8	4.54	76.0	63.5	25.4	111	16.0	28.4	36.6	54.0	34.0	123	96.0

\* Ultimate Load is 4 times the Working Load Limit.

# Replacement Hooks for Chain Hoists



- Available in Working Load Limits of 1.7, 2.3, and 4.2 Tons.
- Fits 1/4" through 9/16" hoist chain.
- Hooks are forged alloy steel - Quenched and Tempered.
- A Product Identification Code (PIC) for material traceability, the size, and the name Crosby or "CG" are forged or stamped onto each hook and swivel assembly (chain nest).
- Hooks utilize Crosby standard 319 Shank Hooks with the registered **QUIC-CHECK**® marking.
- Suitable for frequent rotation under load.
- Use in corrosive environment requires shank and nut inspection in accordance with ASME B30.10-1.10.4(b)(5)(c)2009.

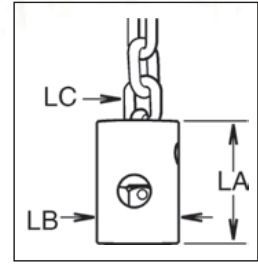

## Link Chain Nest

- **BL-O** – with self-closing gate. • **BL-P** – with manual-closing gate. • With ball-bearing swivel; attaches to chain by alloy pin.

Hook Size	BL-O Stock No.	BL-P Stock No.	Gate Type	Working Load Limit (t)*	Weight Each (kg)	Dimensions (mm)		
						LA	LB	LC
4: 1/4 - 9/32	1051409	1051508	PIN-LOK	1.5	1.13	67.0	44.5	6.35 - 7.15
5: 5/16 - 3/8	1051442	1051541	ROLLOX	2.1	2.04	76.0	57.0	7.95 - 9.50
7: 3/8 - 7/16	1051464	1051563	ROLLOX	3.8	5.0	111	76.0	9.50 - 14.3
7: 1/2 - 9/16	1051486	1051585	ROLLOX	3.8	5.0	111	76.0	9.50 - 14.3

\* Ultimate Load is 4 times the Working Load Limit.



## Roller Chain Nest

- **BL-S** – with self-closing gate. • **BL-R** – with manual-closing gate.
- Attachment with ball-bearing swivel and full-floating connector.

Hook Size	BL-S Stock No.	BL-R Stock No.	Gate Type	Working Load Limit (t)*	Weight Each (kg)	Dimensions (mm)		
						RA	RB	RC
4: #50	1051310	1051200	PIN-LOK	.68	1.32	89.5	44.5	15.9
5: #60	1051321	1051211	ROLLOX	1.13	2.36	108	54.0	19.1
6: #60	1051332	1051222	ROLLOX	1.13	2.81	108	54.0	19.1

\* Ultimate Load is 4 times the Working Load Limit.

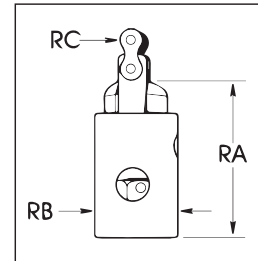

## Open Swivel Bail

- Open Swivel Bail for attachment to link chain.
  - **BL-E** – with self-closing gate. • **BL-G** – with manual-closing gate.
- Suitable for infrequent, non-continuous rotation under load.
- Use in corrosive environment requires shank and nut inspection in accordance with ASME B30.10-1.10.4(b)(5)(c)2009.

Hook Size	BL-E Stock No.	BL-G Stock No.	Gate Type	Working Load Limit (t)*	Weight Each (kg)	Dimensions (in.)			
						UA	UB	UC	UD
3	1051607	1051706	PIN-LOK	1.3	.81	53.0	59.0	13.2	9.65
4	1051618	1051717	PIN-LOK	1.5	.95	54.5	59.0	13.2	9.65
5	1051629	1051728	ROLLOX	2.1	1.45	65.0	67.0	15.7	11.2

\* Ultimate Load is 4 times the Working Load Limit.

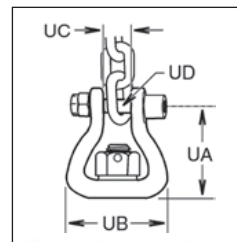



## Crosby® S-4338 Pin Latch

### WARNING & APPLICATION INSTRUCTIONS



### Important Safety Information Read and Follow

- Always inspect hook and pin latch before using.
- Never use a pin latch that is distorted or bent.
- Always make sure internal spring will force the pin latch forward closing throat opening of grab hook. (See Figure 1).
- When a Pin Latch is provided, it is designed to retain loose chain under slack condition.
- Always make sure hook supports the load. The pin latch must never support the load. (See Figure 1, 2, 3 and 4).
- Pin latch is not intended to be an anti-fouling device.
- Recommended for use with Crosby L-1338 or L-1358 Grab Hooks.

### Important – Instructions for Assembling

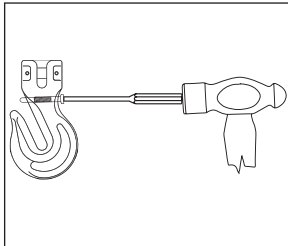

**Step 1:** Using a hammer and the correct roll-pin punch per chart on the right, drive the old latch pin assembly out of hook.

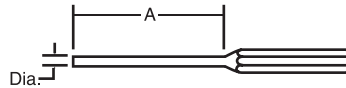

Hook Size (in.)	Hook Size (mm)	Punch Dia. (in.)	A (in.)
1/4	7	7/32	3
5/16	8	7/32	3
3/8	10	7/32	3
1/2	13	5/16	4
5/8	16	3/8	4

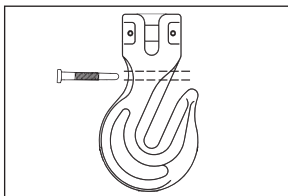

**Step 2:** Insert new S-4338 pin assembly into hook.

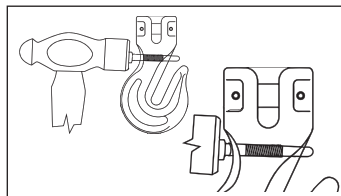

**Step 3:** Using hammer, tap lightly on latch pin head until guide bushing shoulder touches hook.

### WARNING

- Loads may disengage from hook if proper procedures are not followed.
- A falling load may cause serious injury or death.
- Hook must always support the load. The load must never be supported by the pin latch.
- See OSHA Rule 1926.1431(g)(1)(i)(A) and 1926.1501(g)(4)(iv)(B). A hook and this style latch must not be used for lifting personnel.
- Read and understand these instructions before using hook and pin latch.

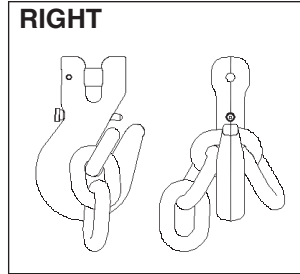

Figure 1

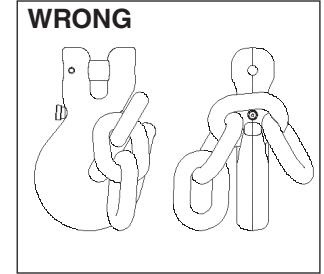

Figure 2

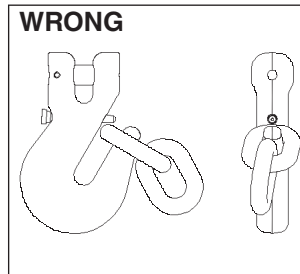

Figure 3

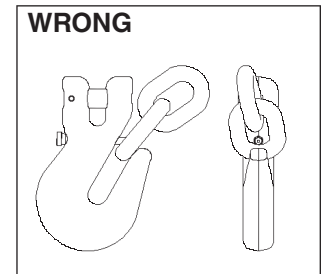

Figure 4

# ALLOY STEEL CHAIN SLINGS AND CROSBY ELIMINATOR®

## WARNING SELECTION, USE & APPLICATION INFORMATION



### WARNING

- Loads may disengage from sling if proper rigging procedures and inspection are not followed.
- A falling load may cause serious injury or death.
- Inspect sling for damage before each use.
- Do not attempt to use sling above rated load and angle upon which it is based.
- Consult sling load chart for capacity reduction due to sling angle or type of hitch used.
- Read and understand these instructions before using sling.

### IMPORTANT SAFETY INFORMATION

#### Read and Follow

These warnings and instructions are applicable to alloy chain slings produced from Crosby Grade 8 (80) and Grade 10 (100) chain and components.

- Only alloy chain, grade 80 (Crosby Spectrum 8®), or grade 100 (Crosby Spectrum 10®), should be used for overhead lifting applications.
- Working Load Limit (WLL) is the maximum load in pounds which should ever be applied to chain, when the chain is new or in "as new" condition, and when the load is uniformly applied in direct tension to a straight length of chain.
- Working Load Limit (WLL) is the maximum working load for a specific minimum sling angle, measured from the horizontal plane. The minimum sling angle and Working Load Limit is identified on the sling.
- The Working Load Limit or Design factor may be affected by wear, misuse, overloading, corrosion, deformation, intentional alterations, sharp corner cutting action diameter of curvature over which the sling is used ( $D/d$ ) and other use conditions.
- Shock loading and extraordinary conditions must be taken into account when selecting alloy chain slings.
- See OSHA Regulation for Slings 1910.184, ASME B30.9-"SLINGS", ASME B30.10-"HOOKS", and ASME B30.26 "RIGGING HARDWARE" for additional information.

ASME B30.9 requires a designated person inspect each new sling and attachments prior to initial use, as well as the user or other designated person perform a visual inspection on a sling each day it is used. In addition, a periodic inspection shall be performed by a designated person at least annually, and shall maintain a record of the last inspection. For further inspection information, see Chain Inspection section of this document, or refer to ASME B30.9-1.9.

#### CAUSE FOR REMOVAL FROM SERVICE

A sling shall be removed from service if any of the following are visible on chain or attachments:

- Wear, nicks, cracks, breaks, gouges, stretch, bend, weld

splatter, discoloration from excessive temperature, throat openings of hooks.

- Chain links and attachments that do not hinge freely to adjacent links.
- Latches on hooks, if present, that do not hinge freely, seat properly or show evidence of permanent distortion.
- Excessive pitting or corrosion.
- Missing or illegible sling identification.
- Makeshift fasteners, hooks, or links formed from bolts, rods, etc.
- Mechanical coupling links in the body of the chain.
- Other damage that would cause a doubt as to the strength of the chain.

### OPERATING PRACTICES

- The weight of the load must be known, calculated, estimated or measured. The loading on the slings will depend on where the center of gravity is located.
- Select sling having suitable characteristics for the type of load, hitch and environment.
- Slings shall not be loaded in excess of the rated capacity.
- Consideration shall be given to the sling load angle which affects rated capacity. (See load chart Table 4 for Grade 100 (SPECTRUM 10®) and Table 5 for Grade 80 (SPECTRUM 8®).
- Never rig a sling with an angle less than 30 degrees to horizontal.
- Slings in a basket hitch should have the load balanced to prevent slippage.
- The sling shall be hitched in a manner providing control of the load.
- Never side load, back load, or tip load a hook.
- Always make sure the hook supports the load. The latch must never support the load.
- Read and understand Crosby hook and hook latch Warnings and Application Instructions.
- For two legged slings with angles greater than 90 degrees, use an intermediate link such as a master link or bolt type shackle to collect the legs of the slings. The intermediate link can be placed over the hook to provide an in-line load on the hook. This approach must also be used when using slings with three or more legs.
- When using chain slings in choker applications, the Working Load Limit must be reduced by 20%. Crosby recommends a minimum angle of choke of 120 degrees (see Figure 1). Consult the manufacturer when planning to use an angle of choke less than 120 degrees. If Crosby A-1338 Cradle Grab Hooks are used at the minimum angle of choke of 120 degrees, the full sling rated WLL can be utilized.
- When using chain slings in basket applications where the  $D/d$  (see figure 2) is less than 6, the rated load must be reduced by the values given in Table 1. This reduction does not eliminate the need to protect chain slings against damage caused by contact with edges, corners, or protrusions. Do not use a chain sling with a  $D/d$  that is less than two.
- In shortening applications, a 20% reduction of the Working Load Limit is required except when using the Crosby A-1338 Cradle Grab Hooks, S-1311 Chain Shortener Link, the A-1355 Chain Choker Hook in conjunction with the S-1325 Chain Coupler Link, or the Crosby ELIMINATOR® shortener link. They can be used without any reduction to the Working Load Limit.



Figure 1

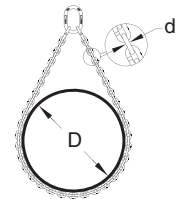

Figure 2



- Slings should always be protected from being damaged by sharp corners.
- Slings should not be dragged on the floor or over abrasive surfaces.
- Chain sling links should not be twisted or kinked.
- Slings should not be pulled from under loads if the load is nesting on the sling.
- Slings that appear to be damaged should not be used unless inspected and accepted by designated person.
- All personnel, including portions of the human body should be kept from between the sling and the load, and from between the sling and the crane hook or hoist hook.
- Personnel shall stand clear of the suspended load.
- Personnel shall not ride the sling.
- Shock loading should be avoided.
- Twisting or kinking the legs (branches) should be avoided.
- During lifting, with or without the load, personnel should be alert for possible snagging.
- When using a basket hitch, the legs of the sling should contain or support the load from the sides, above the center of gravity, so that the load remains under control.
- Sling shall be long enough so that the rated capacity of the sling is adequate when the angle of the legs (branches) is taken into consideration. (See Table 4 for Grade 100 Chain and Table 5 for Grade 80 Chain).

**General Usage**

It must be recognized that certain factors in the usage of chain and attachments can be abusive and lessen the load that the chain or attachments can withstand. Some examples are twisting of the chain; disfigurement; deterioration by straining, usage, weathering and corrosion; rapid application of load or jerking; applying excessive loads; sharp corner cutting, D/d, action and non-symmetrical loading effects.

**Environmental Effects**

- Excessive high or low temperatures or exposure to chemically active environments such as acid or corrosive liquids or fumes can reduce the performance of the chain and components.
- Extreme temperature will reduce the performance of alloy steel chain slings.
- Normal operating temperature is -40°F to 400°F (-40°C to 204°C).
- Reference temperature exposure chart to determine reduction of WLL due to operating at, and after exposure to, elevated temperatures (see Table 2 for Grade 80 Chain and Table 3 for Grade 100 chain).
- Chemically active environments can have detrimental effects on the performance of chain. The effects can be both visible loss of material and undetectable material degradation causing significant loss of strength.

**Special Surface Coating/Plating/Galvanizing**

- Chain should not be subjected to galvanizing, or any plating process. If it is suspected the chain has been exposed to chemically active environment, remove from service.

D/d	Reduction of Basket Hitch Rated Load
2	40%
3	30%
4	20%
5	10%
6 and above	none

Temperature of Chain		Temporary Reduction of Rated Load at Elevated Temperature*	Permanent Reduction of Rated Load After Exposure to Temperature**
(F°)	(C°)		
Below 400	Below 204	None	None
400	204	10%	None
500	260	15%	None
600	316	20%	5%
700	371	30%	10%
800	427	40%	15%
900	482	50%	20%
1000	538	60%	25%
Over 1000	Over 538	OSHA 1910.184 requires all slings exposed to temperatures over 1000° F to be removed from service.	

\* Crosby does not recommend the use of Alloy Chain at temperatures above 800° F.  
\*\* When chain is used at room temperature after being heated to temperatures shown in the first column.

Temperature		Temporary Reduction of Rated Load at Elevated Temperature*	Permanent Reduction of Rated Load After Exposure to Temperature**
(F°)	(C°)		
Below 400	Below 204	None	None
400	204	15%	None
500	260	25%	5%
600	316	30%	15%
700	371	40%	20%
800	427	50%	25%
900	482	60%	30%
1000	538	70%	35%
Over 1000	Over 538	OSHA 1910.184 requires all slings exposed to temperatures over 1000 F to be removed from service.	

\* Crosby does not recommend the use of Alloy Chain at temperatures above 800° F.  
\*\* When chain is used at room temperature after being heated to temperatures shown in the first column.

**CHAIN INSPECTION  
INSPECTION AND REMOVAL FROM  
SERVICE PER ASME B30.9**

**Refer to ASME B30.9-1.9 for further information**

**Frequent Inspection**

- A visual inspection for damage shall be performed by the user or designated person each day the sling is used.
- Conditions such as those listed in ASME B30.9-1.9.4 Removal Criteria, or any other condition that may result in a hazard, shall cause the sling to be removed from service. Slings shall not be returned to service until approved by a qualified person.
- Written records are not required for frequent inspections.

**Periodic Inspection**

- A complete inspection for damage of sling shall be periodically performed by a designated person. Each link and component shall be examined individually, taking care to expose and examine all surfaces including the inner link surface. The sling shall be examined for conditions such as those listed in ASME B30.9-1.9.4 Removal Criteria, and a determination made as to whether they constitute a hazard.
- Periodic Inspection Frequency: Periodic inspection intervals shall not exceed one year. The frequency of periodic inspections should be based on:
  - Frequency of sling use.
  - Severity of service conditions.
  - Nature of lifts being made.
  - Experience gained on the service life of slings used in similar circumstances.



Guidelines for the interval are:

1. Normal Service – yearly
  2. Severe Service – monthly to quarterly
  3. Special Service – as recommended by a qualified person
- c. Written records of the most recent periodic inspection shall be maintained, and shall include the condition of the sling.

**Removal Criteria**

An alloy sling chain shall be removed from service if conditions such as the following are present:

- a. Missing or illegible sling identification.
- b. Cracks or breaks.
- c. Excessive wear, nicks, or gouges. Minimum thickness on chain link shall not be below the values listed in Table 6.
- d. Stretched chain links or components.
- e. Bent, twisted, or deformed chain links or components
- f. Evidence of heat damage.
- g. Excessive pitting or corrosion.
- h. Lack of ability of chain or components to hinge (articulate) freely.
- i. Weld spatter.
- j. For hooks, removal criteria as stated in ASME B30.10.
- k. Other conditions, including visible damage, that cause doubt as to the continued use of the sling.

**Repair**

- a. Slings shall be repaired only by the sling manufacturer or a qualified person.
- b. A repaired sling shall be marked to identify the repairing agency per ASME B30.9 Section 9-1.7.
- c. Chain and components used for sling repair shall comply with



the provisions of ASME B30.9.

- d. Repair of hooks shall comply with ASME B30.10.
- e. Cracked, broken or bent chain links or components other than hooks shall not be repaired; they shall be replaced.
- f. Mechanical coupling links shall not be used within the body of an alloy chain sling to connect two pieces of chain.
- g. Modifications or alterations to the sling or components shall be considered as repairs and shall conform to all other provisions of ASME B30.9.
- h. All repairs shall comply with the proof test requirements of ASME B30.9 Section 9-1.6.

Nominal Chain Size		Minimum Thickness	
(in.)	(mm)	(in.)	(mm)
7/32	5.5	0.189	4.80
9/32	7	0.239	6.07
5/16	8	0.273	6.93
3/8	10	0.342	8.69
1/2	13	0.443	11.26
5/8	16	0.546	13.87
3/4	20	0.687	17.45
7/8	22	0.750	19.05
1	26	0.887	22.53
1-1/4	32	1.091	27.71

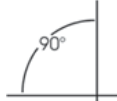
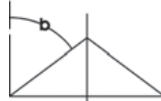
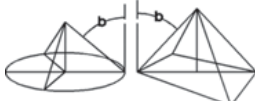

Refer to ASME B30.9

**Table 4**  
Grade 100 (Spectrum 10®) Alloy Chain Working Load Limit – 4 to 1 Design Factor

Nominal Size of Sling							
			Single Leg	Two Leg Slings		Triple and Four-Leg Slings	
(mm)	(in.)	t	0°<β≤45° t	45°<β≤60° t	0°<β≤45° t	45°<β≤60° t	
6	7/32	1,40	2,00	1,40	3,00	2,12	1,12
7	1/4 (9/32)	2,00	2,80	2,00	4,20	3,00	1,60
8	5/16	2,50	3,55	2,50	5,30	3,75	2,00
10	3/8	4,00	5,60	4,00	8,00	6,00	3,20
13	1/2	6,70	9,50	6,70	14,0	10,0	5,35
16	5/8	10,0	14,0	10,0	21,2	15,0	8,00
19	3/4	14,0	20,0	14,0	30,0	21,0	11,2
22	7/8	18,8	26,5	18,8	39,4	28,0	15,0
23	7/8	21,0	29,5	21,0	44,4	31,5	16,8
26	1	27,0	38,0	27,0	57,0	40,0	21,2
32	1-1/4	40,0	56,0	40,0	85,0	60,0	32,5

\* For choker applications, the Working Load Limit must be reduced by 20%. The Crosby A-1338 cradle grab hook and S1311N chain shortener link do not require any reduction of the Working Load Limit. The design factor of 4 to 1 on Spectrum® 10 Alloy Chain agrees with the design factor used by the International Standards Organization (I.S.O.) and ASME B30.9 and is the preferred set of Working Load Limit values to be used. Do not use sling angles of less than 30°.

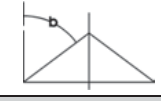
**Table 5**  
Grade 80 (Spectrum 8®) Alloy Chain Working Load Limit – 4 to 1 Design Factor

Nominal Size of Sling							
			Single Leg	Two Leg Slings		Triple and Four-Leg Slings	
(in.)	(in.)	t	0°<β≤45° t	45°<β≤60° t	0°<β≤45° t	45°<β≤60° t	
6	7/32	1,12	1,60	1,12	2,36	1,70	0,90
7	1/4 (9/32)	1,50	2,12	1,50	3,15	2,24	1,20
8	5/16	2	2,80	2	4,25	3	1,60
10	3/8	3,15	4,25	3,15	6,70	4,75	2,50
13	1/2	5,30	7,50	5,30	11,20	8	4,25
16	5/8	8	11,20	8	17	11,80	6,40
19-20	3/4	11,20	16	11,20	23,60	17	9
22	7/8	15	21,20	15	31,50	22,40	12
26	1	21,20	30	21,20	45	31,50	17
32	1-1/4	31,50	45	31,50	67	47,50	25,20

\* For choker applications, the Working Load Limit must be reduced by 20%. The Crosby A-1338 cradle grab hook and S1311N chain shortener link do not require any reduction of the Working Load Limit. The design factor of 4 to 1 on Spectrum® 8 Alloy Chain agrees with the design factor used by the International Standards Organization (I.S.O.) and ASME B30.9 and is the preferred set of Working Load Limit values to be used. Do not use sling angles of less than 30°.

# CROSBY ELIMINATOR®

## WARNING & APPLICATION INSTRUCTIONS

### WARNING

- Failure to read, understand, and follow these instructions may cause death or serious injury.
- Read and understand these instructions before using the Crosby ELIMINATOR®.
- Incorrectly rigging or terminating exerts additional force or loading, which the Crosby ELIMINATOR® is not designed to accommodate.

### Crosby ELIMINATOR® Definitions

The Crosby ELIMINATOR® consists of a bail, hinge bolt, latch pin, and lower body with cradle slot/slots.

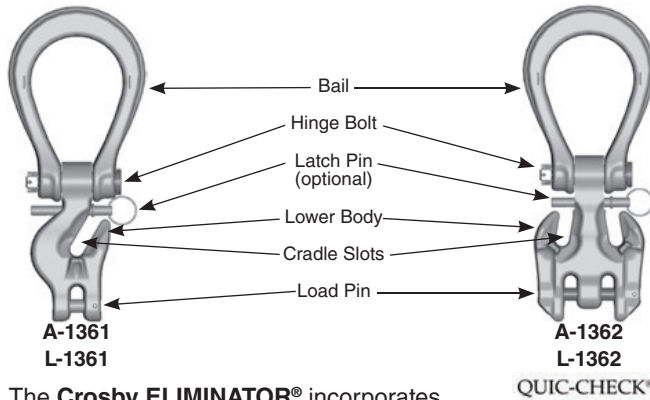

The Crosby ELIMINATOR® incorporates markings forged into the product which address a QUIC-CHECK® feature:

**Deformation Indicators** – Two strategically placed marks on each leg of the bail, which allows for a QUIC-CHECK® measurement to determine if the bail opening has changed, thus indicating abuse or overload. To check, use a measuring device (i.e. tape measure) to measure the distance between the marks. The marks should align to either an inch or half-inch increment on the measuring device. If the measurement does not meet criteria, the Crosby ELIMINATOR® bail should be inspected further for possible damage.

### Important Safety Information Read and Follow

- A visual periodic inspection for cracks, nicks wear, gouges and deformation as part of a comprehensive documented inspection program, should be conducted by trained personnel in compliance with ANSI B30.9.
- Remove from service any Crosby ELIMINATOR® components with a crack, nick, or gouge. The bail and body of a Crosby ELIMINATOR® with nick or gouge shall be repaired by a qualified person. The qualified person shall repair by grinding longitudinally following the contour of the forging, provided that the reduced dimension is within the limits shown in (Fig. A).

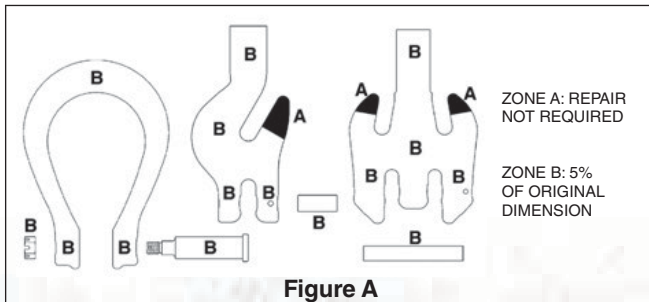

Figure A

- Never repair, alter, rework, or reshape a Crosby ELIMINATOR® by welding, heating, burning, or bending.
- Crosby ELIMINATOR® combination master link and chain shortener shall not be used in a manner other than that for which it is intended.
- The sling may be shortened by use of the cradle slot/slots (see Fig. C).
- In shortening applications, the Crosby ELIMINATOR® can be used without any reduction to the Working Load Limit.
- Never terminate (i.e. place a load bearing chain sling hook), or reeve load bearing chain through Crosby ELIMINATOR® bail. (see Fig. B).
- Never exceed the rated capacity shown on sling's identification tag.
- Attach lifting device to ensure free fit of Crosby ELIMINATOR® bail (see Fig. D). Never allow lifting device to apply forces on side of bail (see Fig. E), as this condition will damage and reduce the capacity of the Crosby ELIMINATOR®.
- The Crosby ELIMINATOR® is intended for tension or pull. Side loading must be avoided, as it exerts additional force or loading which the product is not designed to accommodate. (see Fig. F).



Figure B



Figure C

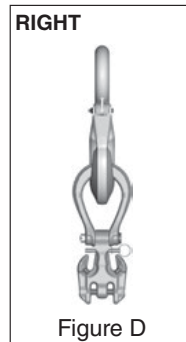

Figure D

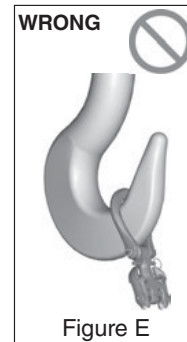

Figure E



Figure F

- Never use a Crosby ELIMINATOR® where the bail shows signs of deformation or overloading (see Table 1).
- Read and understand the other sections of the ALLOY STEEL CHAIN SLINGS Warning, Selection, Use & Maintenance Information.

Chain Size		Frame I.D. Code	Inside Length (mm)	Inside Width (mm)	Jaw Width (mm)	QUIC-CHECK® Dim (mm)
(in.)	(mm)					
1/4 - 5/16	7 - 8	2	98.6	76.2	23.9	88.9
3/8	10	3	122	88.9	28.7	102
1/2	13	4	152	105	33.3	127
5/8	16	5	174	121	41.4	152

- A Crosby ELIMINATOR® under load shall be allowed to self-align itself about the hinge pin.
- The use of a latch may be mandatory by regulations or safety codes; e.g. OSHA, MSHA, ASME B30.10 and B30.9.
- If Crosby latch pin is present, it should fit and function properly, and show no signs of distortion or bending.
- Always make sure the chain is seated in the cradle slot, and the cradle supports the load. The latch pin must never support the load.
- Latch pins are not intended to be an anti-fouling device.
- Use only genuine Crosby repair and latch pins parts.

rev. 3

## A-1361 Single Leg Crosby ELIMINATOR®

- The A-1361 single leg Crosby ELIMINATOR® is designed to support a single leg vertical load. The cradle slot may be used to make a loop in the leg (see Fig. G). However, the Working Load Limit is still limited to the single leg values shown in Table 4 (Grade 100) and Table 5 (Grade 80).
- To produce a single basket hitch and achieve the full Working Load Limit, use only one length of chain with both ends terminated into the load pins of two A-1361 single leg Crosby ELIMINATOR® fittings (see Fig. H). Basket may be shortened with cradle slot.
- Never exceed the single leg Working Load Limit shown in Table 4 (Grade 100) and Table 5 (Grade 80) for an individual A-1361 Crosby ELIMINATOR® fitting.



## A-1362 Double Leg Crosby ELIMINATOR®

- The A-1362 double leg Crosby ELIMINATOR® is designed to support symmetrically loaded double leg slings at 60, 45, and 30 degree horizontal angles. The cradle slots may be used to make loops in the legs (see Fig. J). However, the Working Load Limit is limited to the double leg values shown in Table 4 (Grade 100) and Table 5 (Grade 80).
- To produce a single basket hitch, and achieve the full Working Load Limit, use only one length of chain with both ends terminated into the load pin (see Fig. K). Basket may be shortened with the cradle slot or slots.
- To produce a double basket hitch and achieve the full Working Load Limit, two A-1362 double leg Crosby ELIMINATOR® fittings must be used, with both being terminated at their load pin (see Fig. L).
- Never exceed the double leg / single basket Working Load Limit on an individual A-1362 Crosby ELIMINATOR® fitting.

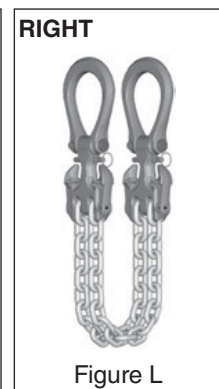



# Lebus® LOAD BINDER

## WARNINGS & APPLICATION INSTRUCTIONS

### WARNING

- Failure to use this load binder properly may result in serious injury or even death to you or others.
- Do not operate load binder while standing on the load.
- Move handle with caution. It may whip – Keep body clear.
- Keep yourself out of the path of the moving handle and any loose chain laying on the handle.
- You must be familiar with state and federal regulations regarding size and number of chain systems required for securing loads on trucks.
- Always consider the safety of nearby workers as well as yourself when using load binder.
- While under tension, load binder must not bear against an object, as this will cause side load.
- Do not throw these instructions away. Keep them close at hand and share them with any others who use this load binder.
- Do not use handle extender – see instructions.
- Do not attempt to close or open the binder with more than one person.

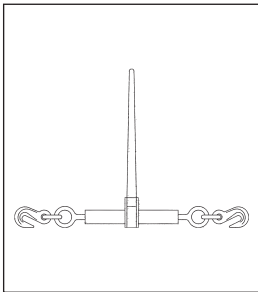

Ratchet Type

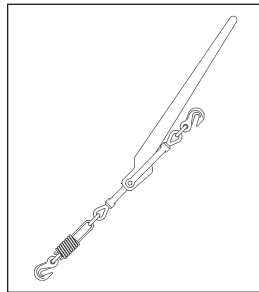

Lever Snubbing Type

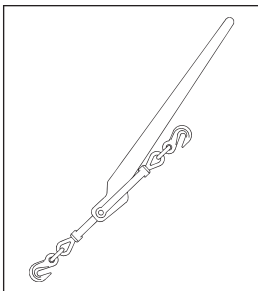

Lever Type

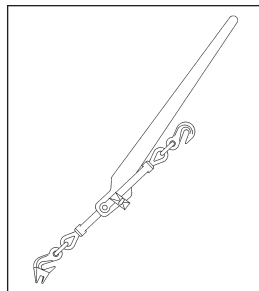

Lever Walking Type

#### Mechanical Advantage

Lever Type Binder = 25 : 1  
Ratchet Type Binder = 50 : 1

**Example:** 50 kilograms of effort applied to the binder results in the following force on the binder.

**Lever Type:**  
50kg. x 25 = 1250 kg of force

**Ratchet Type:**  
50kg. x 25 = 2500 kg of force

## Instructions – Lever Type Load Binders

- Hook load binder to chain so you can operate it while standing on the ground. Position load binder so its handle can be pulled downward to tighten chain (see photo). **Be aware of ice, snow, rain, oil, etc. that can affect your footing. Make certain your footing is secure.**
- The Crosby Group LLC specifically recommends AGAINST the use of a handle extender (cheater pipe). If sufficient leverage cannot be obtained using the lever type load binder by itself, a ratchet type binder should be used.
- If the above recommendation is disregarded and a cheater pipe is used, it must closely fit the handle and must slide down the handle until the handle projections are contacted. The pipe should be secured to the handle, for example, by a pin, so that the pipe cannot fly off the handle if you lose control and let go. The increased leverage, by using a cheater pipe, can cause deformation and failure of the chain and load binder.
- During and after tightening chain, check load binder handle position. **Be sure** it is in the locked position and that its bottom side touches the chain link.
- Chain tension may decrease due to load shifting during transport. To be sure the load binder remains in proper position: Secure handle to chain by wrapping the loose end of chain around the handle and the tight chain, or tie handle to chain with soft wire.
- When releasing load binder, remember there is a great deal of energy in the stretched chain. This will cause the load binder handle to move very quickly with great force when it is unlatched. **Move handle with caution. It may whip – Keep body clear.**
- **Never use a cheater pipe or handle extender to release handle.** Use a steel bar and pry under the handle and stay out of the path of handle as it moves upward.
- If you release the handle by hand, use an open hand under the handle and push upward. **Do not close your hand around the handle. Always keep yourself out of the path of the moving handle.**



## Instructions - Ratchet Load Binders

- Position ratchet binder so it can be operated from the ground.
- **Make sure your footing is secure.**

## Maintenance of All Load Binders

- Routinely check load binders for wear, bending, cracks, nicks, or gouges. **If visual wear bending or cracks are present - Do not use load binder.**
- Routinely lubricate pivot and swivel points of Lever Binders, and pawl part and screw threads of Ratchet Binders to extend product life and reduce friction wear.

## Crosby® SHUR-LOC® HOOKS

### WARNING & APPLICATION INSTRUCTIONS



### Important Safety Information - Read and Follow

- A visual periodic inspection for cracks, nicks, wear, gouges and deformation as part of a comprehensive documented inspection program, should be conducted by trained personnel in compliance with the schedule in ASME B30.10.
- For hooks used in frequent load cycles, pulsating loads, or severe duty as defined by ASME B30.10, the hook and threads should be periodically inspected by Magnetic Particle or Dye Penetrant. **(Note: Some disassembly may be required.)**
- Never use a hook whose throat opening has been increased 5%, not to exceed 1/4" (6mm), or shows any visible apparent bend or twist from the plane of the unbent hook, or is in any other way distorted or bent. **NOTE: A latch will not work properly on a hook with a bent or worn tip.**
- Never use a hook that is worn beyond the limits shown in Figure 1.
- Remove from service any hook with a crack, nick, or gouge. Hooks with a nick or gouge shall be repaired by grinding lengthwise, following the contour of the hook, provided that the reduced dimension is within the limits shown in Figure 1. Contact Crosby Engineering to evaluate any crack.
- Never repair, alter, rework, or reshape a hook by welding, heating, burning, or bending.
- Never side load, back load or tip load a hook. Side loading, back loading and tip loading are conditions that damage and reduce the capacity of the hook. (See Figure 2)
- S-1326A can be used for limited rotations under load, (infrequent, noncontinuous).
- Efficiency of synthetic sling material may be reduced when used in eye or bowl of hook.
- Always make sure the hook supports the load. (See Figure 3).
- Do not use hook tip for lifting (See Figure 4).

### ⚠ WARNING

- Loads may disengage from hook if proper procedures are not followed.
- A falling load may cause serious injury or death.
- Positive locking latch will unlock when trigger is depressed. Never use hook unless hook and latch are fully closed and locked.
- Keep body parts clear of pinch point between hook tip and hook latch when closing.
- Keep hand(s) from between throat of hook and sling or other device.
- Do not use hook tip for lifting.
- Do not use hook handle for lifting.
- Shank threads may corrode and/or strip and drop the load.
- Remove securement nut to inspect threads for corrosion or to replace S-1326A bearing washers (2) and or S-13326 thrust bearing.
- Never apply more force than the hook's assigned Working Load Limit (WLL) rating.
- See OSHA Rule 1926.1431(g)(1)(i)(A) and 1926.1501(g)(4)(iv)(B) for personnel hoisting by cranes or derricks. A Crosby 1318A, 1326A, 13326, 1316A, or 1317A hook may be used for lifting personnel.
- Use only genuine Crosby parts as replacements.
- Read and understand these instructions before using hook.

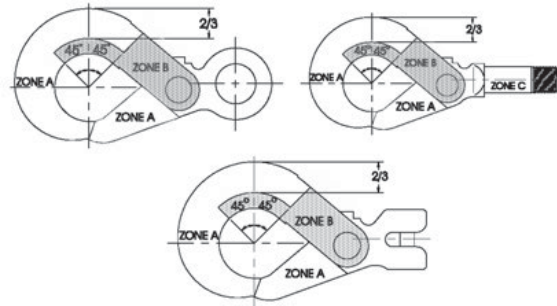

ZONE A: 10% OF ORIGINAL DIMENSION  
 ZONE B: 5% OF ORIGINAL DIMENSION  
 ZONE C: SEE MINIMUM THREAD SIZE CHART

FIGURE 1

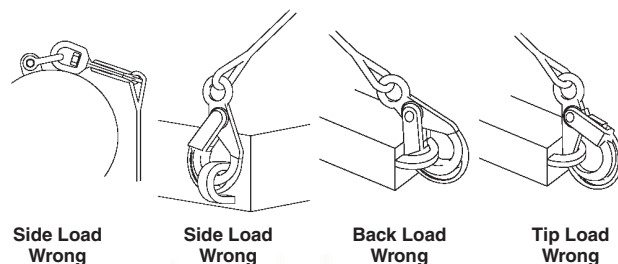
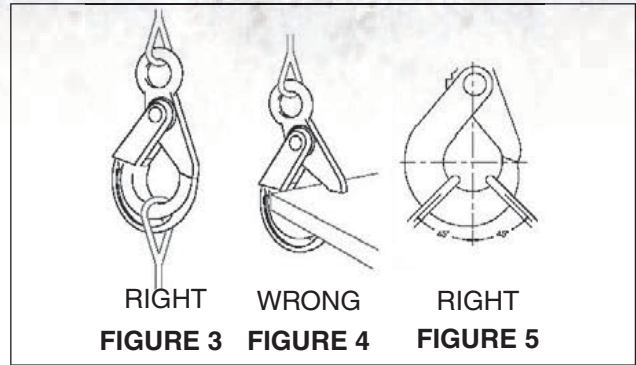

FIGURE 2

- When placing two (2) sling legs in hook, make sure the angle from vertical to the leg nearest the hook tip is not greater than 45 degrees, and the included angle between the legs does not exceed 90 degrees\* (See Figure 5).
- \* For two legged slings with angles greater than 90°, use an intermediate link such as a master link or bolt type shackle to collect the legs of the slings. The intermediate link can then be placed over the hook to provide an in-line load on the hook. This approach must also be used when using slings with three or more legs.

- See ANSI/ASME B30.10 "Hooks" for additional information.
- The hook handle of the 1316AH is for manipulation only and not intended to carry a load.



### Important Basic Machining and Thread Information: Read and Follow

- Wrong thread and/or shank size can cause stripping and loss of load.
- The maximum diameter is the largest diameter, after cleanup, that could be expected after allowing for straightness, pits, etc.
- All threads must be Class 2 or better.
- The minimum thread length engaged in the nut should not be less than one (1) thread diameter.
- Hook shanks are not intended to be swaged on wire rope or rod.
- Hook shanks are not intended to be drilled (length of shank) and internally threaded.
- Crosby cannot assume responsibility for, (A) the quality of machining, (B) the type of application, or (C) the means of attachment to the power source or load.
- Consult the Crosby Hook Identification & Working Load Limit Chart (See below) for the minimum thread size for assigned Working Load Limits (WLL).†
- Remove from service any Hook which has threads corroded more than 20% of the nut engaged length.

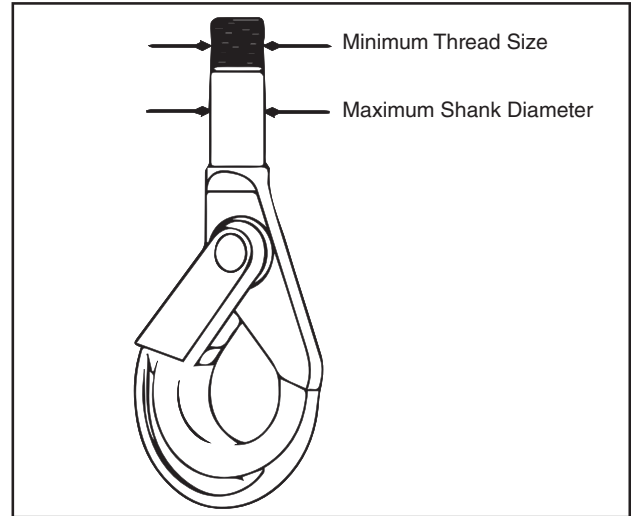

### Crosby® Hook Identification & Working Load Limit Chart†

S-1316A & S-1317A Only Grade 100 Chain			S-1318AH ††, S-1326A, S-13326						S-1318A Only		
Chain Size		Working Load Limit (t)** 4:1	Grade 100 Chain			Wire Rope XXIP Mechanical Splice			Maximum Shank Diameter		Minimum Thread Size (in.)
(mm)	(in.)		Chain Size		Working Load Limit (t)** 4:1	Wire Rope Size (mm)		Working Load Limit (t)* 5:1	(mm)	(in.)	
			(mm)	(in.)		(mm)	(in.)				
6	—	1.45	6	—	1.45	8	5/16	1.00	18	.72	5/8 - 11 UNC
7	1/4	1.95	7 - 8	1/4	1.95	11	3/8	1.91	24	.94	5/8 - 11 UNC
8	5/16	2.59	8	5/16	2.59	11	1/2	1.91	24	.94	3/4 - 10 UNC
10	3/8	3.99	10	3/8	3.99	13	5/8	3.90	27	1.06	3/4 - 10 UNC
13	1/2	7	13	1/2	7	16	3/4	5.62	30	1.19	1-1/8 - 7 UNC
16	5/8	10	16	5/8	10	22	7/8	7.53	35	1.38	1-3/8 - 6 UNC
18/20	3/4	16	18-20	3/4	16	26	1	9.98	—	—	—
22	7/8	19	22	7/8	19	29	1-1/8	12.02	—	—	—
26	1	27	26	1	27	32	1-1/4	14.74	—	—	—

\* Ultimate Load is 5 times the Working Load Limit based on XXIP Wire Rope.

\*\* Ultimate Load is 4 times the Working Load Limit based on Grade 100 Chain.

† Working Load Limit - The maximum mass of force which the product is authorized to support in general service when the pull is applied in-line, unless noted otherwise, with respect to the centerline of the product. This term is used interchangeably with the following terms: 1. WLL, 2. Rated Load Value, 3. SWL, 4. Safe Working Load, 5. Resultant Safe Working Load. †† Based on minimum thread size for assigned WLL.





# Lebus® L-180 WINCHLINE TAIL CHAIN

## WARNING & APPLICATION INSTRUCTIONS



L-180

**WARNING**

- Loads may disengage from winchline tail chain if proper procedures are not followed.
- A falling load or disengaged winchline tail chain may cause serious injury or death.
- Inspect winchline tail chain for damage before each use.
- Wire rope should not be terminated to tail chain by the use of a knot.
- Do not attach slings or other devices in hook for overhead lifting – see operating practices.

### Important Safety Information – Read & Follow

- Only winchline tail chains made from alloy chain, Grade 80 or Grade 100, should be used for overhead lifting applications.
- Working Load Limit (WLL) is the maximum load in pounds which should ever be applied to winchline tail chain.
- The Working Load Limit or Design Factor may be affected by wear, misuse, overloading, corrosion, deformation, intentional alterations, sharp corner cutting action and other use conditions.
- Never repair, alter, rework, or reshape a hook or chain by welding, heating, burning or bending.
- Recommended for IPS or XIP (EIP), RRL, FC or IWRC wire rope.
- Shock loading and extraordinary conditions must be taken into account when selecting winchline tail chains.

### CAUSE FOR REMOVAL FROM SERVICE

A winchline tail chain shall be removed from service if any of the following are visible on chain or hook:

- Wear, nicks, cracks, breaks, gouges, stretch, bend, weld splatter and discoloration from excessive temperature. Minimum thickness on chain link shall not be below the values listed on Table 1.
- Chain links and hook that do not hinge freely to adjacent links.
- Excessive pitting or corrosion on chain, hook or termination fitting.
- Makeshift fasteners, hooks, or links formed from bolts, rods, etc.

L-180 Stock No.	Wire Rope Diameter (mm)	Nominal Chain Size	
		(mm)	(in.)
1091473	8 - 10	10	3/8
1091482	13 - 16	16	5/8
1091511	19 - 22	22	7/8
1091516	25 - 29	26	1
1091525	25 - 29	26	1
1091532	32	32	1-1/4

- Mechanical coupling links in the body of the chain.
- Other damage that would cause a doubt as to the strength of the chain.
- Winchline tail chain should not be subjected to galvanizing or any plating process. If it is suspected the chain has been exposed to chemically active environment, remove from service.
- Termination end attachments that are cracked, deformed, or worn.
- For wire rope inspection procedures and removal from service criteria refer to manufacturer's recommendations.

### OPERATING PRACTICES

- Know the winch lifting/pulling systems capacity rating.
- Know the applied load on tail chain. In dragging applications, the applied load may be greater or less than its weight due to friction.
- During lifting/dragging with or without the load, personnel should be alert for possible snagging.
- WORKING LOAD LIMIT (WLL) is the maximum load in pounds which should ever be applied to winchline tail chain when the chain is new or in as-new condition, and when the load is uniformly applied in direct tension to a straight length of chain.

Wire Rope Diameter (mm)	L-180 Stock No.	Working Load Limit 3.5 to 1 Design Factor (kg)
8 - 10	1091473	2450
13 - 16	1091482	5900
19 - 22	1091511	15510
25 - 29	1091516	21640
25 - 29	1091525	21640
32	1091532	33200

10mm through 16mm made from Grade 40 High Test carbon steel.  
22mm through 32mm made from Grade 80 or Grade 100 alloy steel. Only alloy tail chain should be used for overhead lifting applications.

- Wire rope termination efficiency and tail chain Working Load Limit (WLL) must be considered when selecting termination fitting and tail chain.
- Efficiency of wire rope end termination is based on the catalog breaking strength of wire rope.

Typical Termination Method & Efficiency	
Termination	Efficiency
S-409 Swage Button	80%

- The winchline tail chain hook is designed to fit the winchline diameter when hooked or connected back to winchline (See Figure 1).
- When used to pull or drag a load, the winchline tail chain may be wrapped around the load and the hook connected to the winchline. Also, when used to pull or drag a load over the tail board roller, the tail chain hook may be attached directly to the load at a connection point authorized by a competent rigger (See Figure 5). In either case, a visual verification of proper hook engagement is required during the entire operation.
- When used in overhead lifting applications, the winchline tail chain may be wrapped around the load and the hook connected to the winchline (See Figure 1). Used in this manner, this connection provides the same load control advantages and limitations as a single leg wire rope sling basket or choker hitch. The winchline tail chain should

contain and support the load from the sides, above center of gravity, so load remains under control. A visual verification of proper hook engagement is required during the entire operation.

- The tail chain hook has no provision for a latch; therefore, The Crosby Group, LLC. specifically recommends AGAINST placing the load, slings or other devices directly into the tail chain hook for the purpose of overhead lifting. A latch may be mandatory by regulations or safety codes: e.g. OSHA, MSHA, ASME B30, insurance, etc. (See Figure 2).

**If the above Crosby recommendation is disregarded and slings or other devices are placed directly into the tail chain hook, as a minimum ensure:**

- Personnel shall stand clear of the suspended load.
- Visual verification of proper hook engagement is required in all cases.
- The sling or device should be centered in the base (bowl/saddle) of the hook.
- The user must assure connection to the hook is secure throughout the movement of the load.
- A designated competent rigger must verify that all appropriate rigging practices are followed for attachment and control of load.
- The winchline and tail chain links should always be protected from being damaged by sharp corners (See Figure 3).
- Chain links should not be twisted or kinked.
- Winchline or tail chain should not be pulled from under loads if the load is resting on winchline or tail chain.
- Winchline or tail chain that appears to be damaged should not be used unless inspected and accepted by a designated person.
- Never side load, back load, or tip load hook (See Figure 4).
- All portions of the human body should be kept from between the winchline / tail chain and load.
- Personnel shall stand clear of the suspended load.
- Shock loading should be avoided.
- Extreme temperature will reduce the performance of winchline tailchain.
- Normal operating temperature is -40°F to 400°F (-40°C to 204°C).

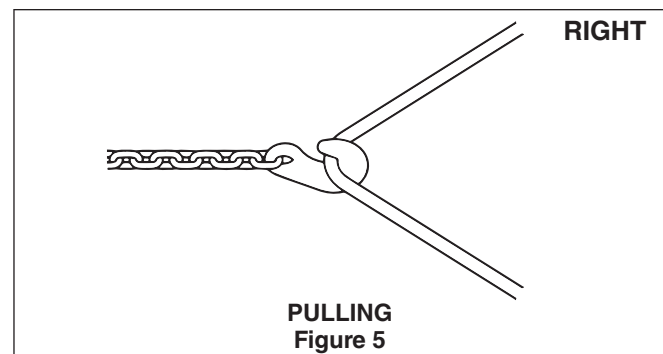
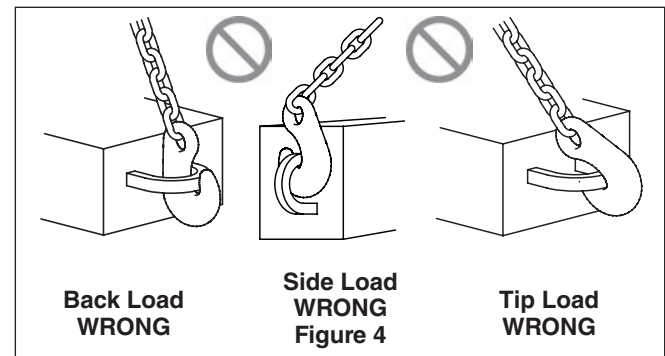
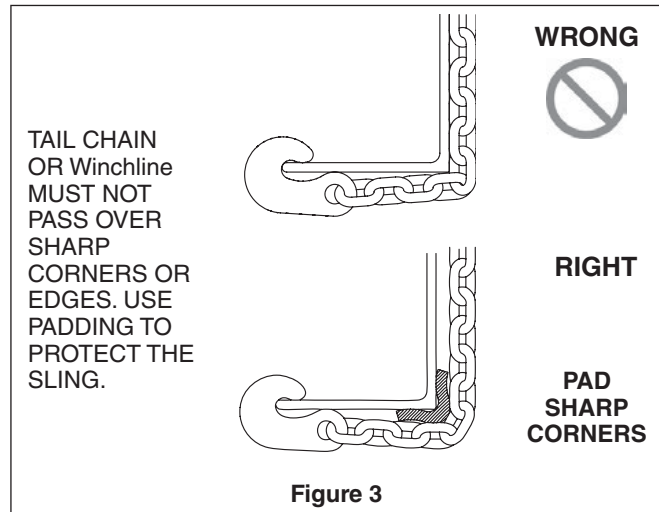
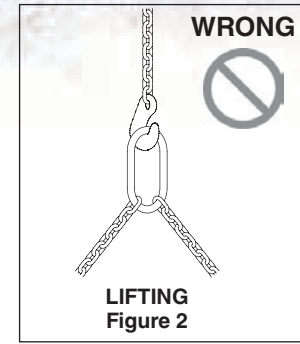
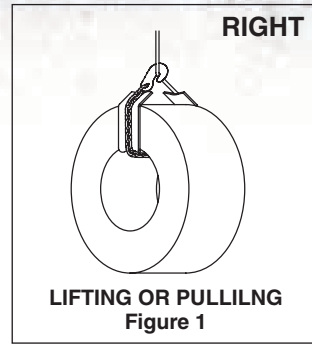



# Alloy Fittings Application and Information

## HOW TO ASSEMBLE AN S-1325 COUPLER LINK ONTO MASTER LINK



Slide Coupler Link over Engineered Flat of Master Link.



Rotate Coupler Link so that clevis fitting is to the outside of Master Link and attach to chain sling.

## HOW TO ASSEMBLE A CROSBY CLEVIS TYPE FITTING



1. Place chain link into clevis of chain coupler. Insert pin fully into the clevis ears.



2. Place the coupler link on its side and using a hammer, drive the locking pin into the clevis ear until it is flush with the outside surface.

## HOW TO ASSEMBLE A LOK-A-LOY® CONNECTING LINK



1. Place the locking sleeve between the assembled half link forgings.



2. Drive the pin through the assembled link ends and sleeve until the end of the pin is flush with the outside of the connecting link halves.

## HOW TO ASSEMBLE LOAD PIN IN CROSBY ELIMINATOR® FITTINGS



1. Place both chain links into clevis slots of fitting, insert pin fully into the two-leg clevis.



2. Place Eliminator assembly on a firm surface. Using a hammer, drive the locking pin into the two-leg clevis until it is flush with the top of the hole.

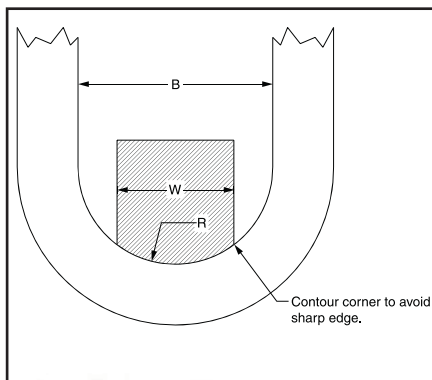

Figure 1

Crosby master links and master link assemblies are proof tested with special fixtures in accordance with ASTM A952. While other specifications such as EN 1677-4 and AWRP Recommended Guideline for Proof Test Procedures for Slings related to master link and master link assemblies also allow for the use of special fixtures when proof testing, Crosby follows the guidelines set forth in ASTM A952. The purpose of the special fixture is to prevent localized point loading during the proof test. Point loading at the proof test load may result in permanent deformation. The proof test fixture per ASTM A952 allows for a maximum fixture width (W) of 60% of the inside width (B) of the master link. The radius of the fixture (R) is one-half of inside width of the master link. A sketch showing an example of the special fixture is shown in Figure 1. Note that the corner of the fixture should be contoured so that a sharp edge does not make contact with the master link during the loaded condition.

Over the years some master links and master link assemblies have changed dimensions and working load limits. Special consideration should be given to the actual inside width of the master link being tested and its correct allowable proof load value. If the correct allowable proof load value is in question, then Crosby Engineering should be consulted for the appropriate proof load value.





# McKISSICK SHEAVES

With Product Warnings and Application Information





**Crosby**

**"There is No Equal"**



The Market Leader: Yesterday Today and Tomorrow

## McKissick Sheaves

### HISTORY & EXPERIENCE

The ability to match the sheave design and manufacturing process to meet the application requirements requires experience. It also requires the ability to creatively use this experience and manufacturing resources to provide the best solution.

### THE COMPETITION

- Ask:** *What is their history and experience?*
- Ask:** *What processes do they have available to draw upon?*
- Ask:** *What technical experience do they have available to provide technical solutions to technical demands?*

**Crosby**

McKissick has provided sheaves to energy and lifting industries since the early 1900's. Since McKissick became part of Crosby in the mid 1900's there has been a continuous history of product and process development. Crosby invented the roll forged sheave in 1978 and continues to be a leader today in sheave design and manufacturing process.

### DELIVERY & ACCESSIBILITY

Many energy and lifting sheave applications require short delivery times and delivery to locations around the world. Response times require flexible manufacturing resources. Access around the world requires not only logistics experience and capabilities, but also requires manufacturing resources strategically located around the world.

### THE COMPETITION

- Ask:** *How do they support short deliveries?*
- Ask:** *What is their experience providing worldwide delivery?*
- Ask:** *What resources do they have in key areas of the world?*

**Crosby**

Crosby-McKissick stocks key raw materials and has an extensive bank of tooling and sufficient manufacturing capacity to support short deliveries. Crosby has McKissick block and sheave centers that serve their local markets in Tulsa, Oklahoma (USA); Putte, Belgium; Singapore; and Hangzhou, China.

### FLEXIBILITY OF DESIGN

Matching the best solution to the application requires the ability to fabricate sheaves by a number of processes:

- 1) Heavy Duty – Roll forged sheaves are hot forged with no splitting stresses at base for sheaves up to 78".
- 2) Heavy Duty – Closed die forged sheaves with machined Wireline groove for sheaves up to 16".
- 3) Extreme Duty – Roll forged sheaves with welded dome reinforcement employ the latest welding technology with no shape cross brace stress concentration areas.
- 4) Heavy Duty fabricated sheaves – With welded rings and reinforced webs utilizing the latest welding technology.
- 5) The ability to provide sheave grooves with 30, 35 and 45 degree profiles as well as other special profiles.
- 6) The ability to provide bearings to match application: Plain bore, bronze bushed, roller bearings, tapered roller bearings and full complement bearings.
- 7) Heat treatment of Wireline groove to provide wear resistance.

### THE COMPETITION

- Ask:** *How do they achieve the performance required with a split or cast sheave?*
- Ask:** *How do they resolve the welding stresses induced when you fabricate the sheave?*
- Ask:** *What sheave groove profile do they provide on a regular basis?*
- Ask:** *Do they have technical expertise to recommend proper sheave bearings?*
- Ask:** *How do they provide for proper Wireline groove life?*

**Crosby**

McKissick offers roll forged sheaves that provide an upset metal flow without creating a stress zone at the splitting point. The dome-reinforced sheave design provides for a continuous weld in a circular pattern. McKissick produces sheaves in 30, 35, and 45 degree profiles, and can provide special profiles as required. Extensive experience underwater and in harsh and demanding environments gives McKissick the needed experience in selecting sheaves for all applications. From material selection to hardening of the groove, McKissick sheaves provide the needed wireline life.

### SPECIFICATIONS

Many energy and lifting sheaves must meet standards. These standards include API, ABS, DIN, DNV and ASME. Demanding specifications for sheaves used in demanding applications also include strength, fatigue, impact and non-destructive testing.

### THE COMPETITION

- Ask:** *Do they understand and have experience in meeting the industry standards such as API, ABS, DIN, DNV and ASME?*
- Ask:** *Do they have a history of gaining required approvals?*
- Ask:** *Are they licensed to manufacture sheaves to API 8C?*

**Crosby**

Crosby McKissick has achieved API Q1, and TS29001 Status, and is licensed to manufacture sheaves to API 8C. Sheaves are frequently provided to API, DNV and ABS requirements.

### TECHNICAL SUPPORT & TRAINING

The selection, use, inspection and maintenance of sheaves requires technical support. This technical support includes engineering services, training support and the ability to meet the various industry requirements around the world.

### THE COMPETITION

- Ask:** *What technical support do they provide?*
- Ask:** *Where is this support provided from?*
- Ask:** *What training is available to support the selection, use, inspection and maintenance of sheaves?*

**Crosby**

Crosby has technical and operational support available from each of our McKissick Block and Sheave Centers around the world. Crosby provides extensive training through our one day Block and Sheave Clinics and our two-day Heavy Lift Seminars. Industry-specific training is also provided.

**Remember: "When buying Crosby, you're buying more than product, you're buying Quality."**

# Crosby® VALUE ADDED

**McKissick® Roll-Forged Heavy Duty Sheaves** are made by upsetting and forming the groove and flange walls in multiple steps, eliminating the need to split and weaken the groove. This exclusive forging process adds extra strength to the critical groove section.

**McKissick Domed Reinforced Extreme Duty Roll Forged Sheaves** are welded in a circular pattern thus eliminating the higher stresses created by welding ribs or other forms of stiffeners.

**McKissick Heavy Duty Sheaves** are available with machined groove rings or machine forged rings utilized for the rim or hub.

**McKissick Heavy Duty Closed-Die Forged Sheaves** offer the performance of closed-die forging with the precision machining capabilities of CNC machinery.

**McKissick Normal Duty Malleable Cast Sheaves** provide economical solutions for normal service applications.

**McKissick Sheaves** come in a variety of sizes to suit your specific applications. Crosby offers many sheaves as standard and these are shown in the pages that follow. For applications that require unique specifications, Crosby can make minor modifications to many of the sheaves listed at a reasonable charge. We can also custom design and manufacture sheaves to your exact requirements. McKissick roll forged sheaves can be furnished balanced or with lightening holes at a reasonable charge on request.

**Crosby's Hardening Technique** is a science. It provides a precise maximum hardness for wear-resistance across the wire rope contact area. The McKissick sheave groove is flame hardened to a minimum 35 Rockwell C for a 140° contact area with the wire rope (upon special request the McKissick sheave groove can be flame hardened to a minimum 50 Rockwell C for a 150° contact area with the wire rope). The solid steel plate provides the ideal surface for flame hardening and a closer tolerance fit to the wire rope to reduce fatigue and wear.

**The McKissick Hub** is stepped to eliminate stress failure in the weld, common in traditional hub designs. The hub is pressed into place with complete metal-to-metal contact. This helps ensure an accurate alignment to the hub's axis so there is no wobble or lopping of the rotating sheave. The precision aligned hub / sheave wheel combination adds to the bearing life and keeps the sheave on the job longer.

## McKISSICK® STANDARD BEARINGS



(B) Bronze Bushing



(R) Roller Bearings



(W) Roller Bearing  
with Thrust Washers



(C) Full Complement Cylindrical  
Roller Bearing



(T) Tapered Roller  
Bearing

## McKISSICK® Wireline GROOVE PROFILES

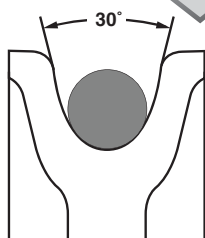

API STYLE  
30 degrees

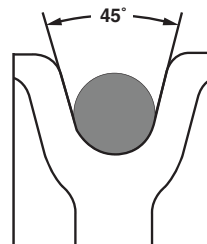

EUROPEAN STYLE  
45 degrees

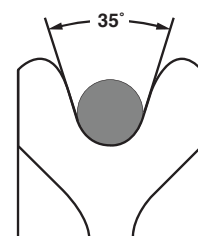

AISE STYLE  
35 degrees

Custom sheaves are available. See page 287 for ordering details.



# DO NOT BE FOOLED

## The Elements of a Superior Sheave.

Every McKissick® Roll-Forged sheave starts as a single piece of AISI C-1035 carbon steel plate. Utilizing a “time proven” proprietary roll forging process that adds extra strength to the critical groove section, the sheave is formed from a precision flame cut blank. The hub is then pressed into place with complete metal-to-metal contact and secured with a deep penetrating weld to ensure proper fit and longer life. Before the McKissick® name is added, each sheave is thoroughly inspected to meet applicable industry and Crosby® quality standards.

**McKissick® Roll-Forged sheaves contain the following critical standard features required to meet your demanding applications.**

**1** Smooth radius at the rim provides superior transition from outside diameter to groove - eliminating sharp corners that can damage rope

- Cold formed split steel sheaves may contain a sharp transition radius at rim of sheave



**2** Size for size, McKissick® Roll-Forged sheaves have a thicker section under the tread of the Wireline groove - providing more substantial support of the Wireline

- Cold formed split steel sheaves are limited to a thinner section thickness under the groove, reducing sheave life in heavy service conditions
- Thinner sections produce a sharp corner under the tread, resulting in potential stress risers

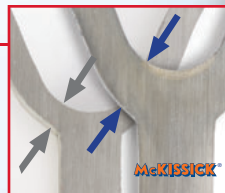

**3** Thicker web on sheave provides required stiffness to support a stronger sheave that contains thicker flange sections

- The thinner web on cold formed split steel sheaves, inherent to the process, does not support thicker flange sections
- The sharp, pointed cutter used in forming the groove during the cold formed split steel process may produce a concealed crack in the bottom of the groove

	McKissick®	Cold Formed Split Steel
Smooth Radius Edge - Better fit, less wear on rope	✓	
Thicker Fleet Section - Better support, stronger sheave groove	✓	
Deep Penetrating Weld at Hub - Longer life	✓	
Flame Hardened Groove - Higher Rockwell C rating	35Rc	14Rc
Roll Forging Process - Provides superior grain flow	✓	



**There is no sheave like a McKissick® Roll-Forged Sheave**

# ...into thinking all sheaves produce the same results.



**4** Heavier flange sections - provide a much stronger wire rope groove and maintain proper consistent groove angles, ensuring long term Wireline performance

- Cold formed split steel sheaves tend to have flange sections that are thinner as well as variations in thickness on the same sheave, resulting in less than desired performance during critical applications
- Cold formed split steel sheaves are limited to a maximum flange thickness of 50% of web section

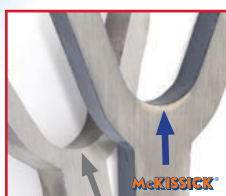

**5** Minimum 35Rc for higher hardness in the bottom of the groove - results in less wear to the sheave, thus extending life of Wireline

- Unless requested at time of order, cold formed split steel sheaves have a much lower hardness rating (approx. 14Rc)
- The standard material used in cold formed split steel process may not allow higher hardness in groove

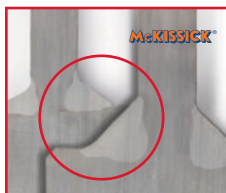

**6** Precision alignment of hub with blank, then finished with a deep penetrating weld - ensuring proper fit, longer life and confidence during the most extreme of applications

**Cold Formed Split Steel Sheave**

#### Additional Important Features of McKissick® Roll-Forged Sheaves

- The grain flow associated with the McKissick® Roll-Forged sheave process results in excellent performance properties.
- Each sheave is permanently marked with “McKissick®”, sheave outside diameter, Wireline size and Product Identification Code (PIC) that provides complete material traceability.

**Crosby® and McKissick® Roll-Forged Sheaves  
Reliability You Can Depend On**



**Crosby®**

[www.thecrosbygroup.com](http://www.thecrosbygroup.com)



**HEAVY DUTY SHEAVES**  
FROM 305mm THROUGH 1981mm

**Stepped Hub Design Proves Better**

The McKissick hub is stepped to eliminate stress failure in the weld, common in traditional hub designs. The hub is pressed into place with complete metal-to-metal contact. This helps ensure an accurate alignment to the hub's axis so there is no wobble or lopping of the rotating sheave. The precision aligned hub/sheave wheel combination adds to the bearing life and keeps the sheave on the job longer.

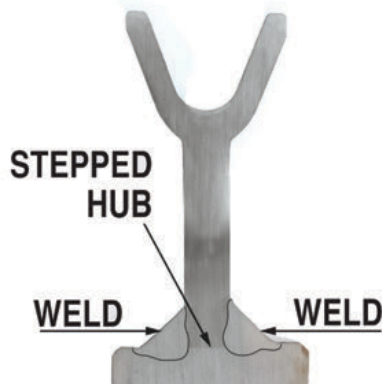

**Closed Die Upset and Roll Forged – Not Split**

Upsetting and roll forging forms the groove and flange walls in multiple steps, eliminating the need to split and weaken the groove. This exclusive forging process adds extra strength to the critical groove section. You can count on a McKissick sheave to give maximum life performance, because it's forged to distribute the Wireline forces evenly over an accurately formed load surface. Plus, uniformity of the roll forged groove adds longer Wireline life.

**Full Range of Standard Sheave Sizes**

McKissick Roll-Forged sheaves are available in a full range of sizes from 305mm to 1981mm and bearing styles and prices that best fit your application. Crosby also manufactures custom McKissick sheaves and can make minor modifications to standard sheaves as needed for special applications.



**Solid Steel – No Casting**

Every McKissick sheave starts as a single piece of solid carbon steel plate. It's flame-cut from closely checked stock, so there's no inherent web/rim flaw as you find in cast sheaves. There's better balance and better distribution of forces with a McKissick Roll-Forged sheave too. Casting can result in groove wall variations – either too thick or too thin – causing uneven stresses and early failure.

Full penetration weld is standard on 40" and larger sheaves.

**NOTE: Custom Sheaves are Available. See Page 287 for Ordering Details.**

**Flame Hardened Groove**

Crosby's hardening technique is a science. It provides a precise maximum hardness for wear-resistance across the Wireline contact area. The McKissick sheave groove is flame hardened to a minimum 35 Rockwell C for a 140° contact area with the Wireline (upon special request the McKissick sheave groove can be flame hardened to a minimum 50 rockwell C for a 150° contact area with the Wireline). The solid steel plate provides the ideal surface for flame hardening and a closer tolerance fit to the Wireline to reduce fatigue and wear.

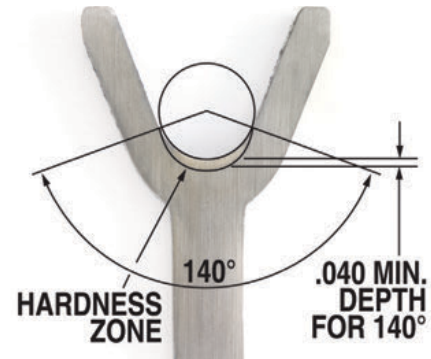

**Bearing Selection to Match Your Job Requirement**

The McKissick Roll-Forged sheave is available in the following configurations:

- Plain bore
- Bronze bushed
- Roller bearing
- Tapered roller bearing
- Lubrication thru hub
- Key ways
- Set screws
- Full Complement Bearing



Licensed Under  
API Spec 8C-0021

Sheaves are available to API 8C.







## DOMED SHEAVES

610mm AND LARGER

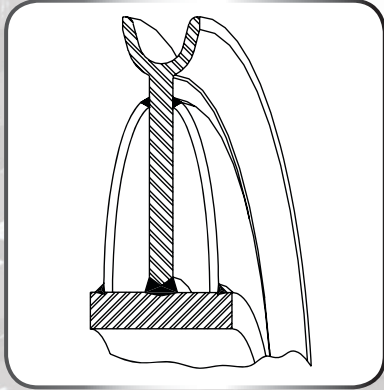

### Eliminates High Stress Weld Intersections

McKissick® Domed Roll-Forged sheaves are welded in a circular pattern thus eliminating the higher stresses created by welding ribs or other forms of stiffeners.



U.S. Patents D621, 240

### Large Range of Sheave Sizes Available

McKissick Domed reinforced Roll-Forged sheaves are available in sizes 610mm and larger, and bearing styles that best fit your extreme duty applications.

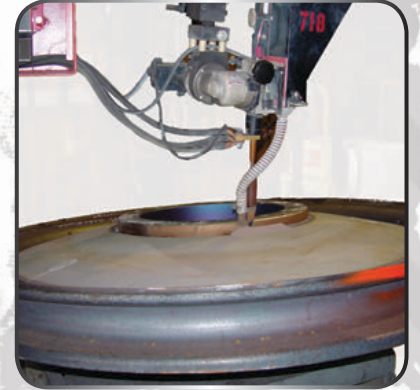

### Roll Forged Sheave and Latest in Welding Technology

McKissick Domed Roll-Forged™ sheaves have the strength, fatigue properties and rigidity needed for those "extreme duty sheaves" with high working stress and side loading.

## McKissick® Fabricated Sheaves

Custom sheaves are available. See page 287 for ordering details.

## HEAVY DUTY SHEAVES

AVAILABLE THROUGH 2,946mm IN OUTSIDE DIAMETER.

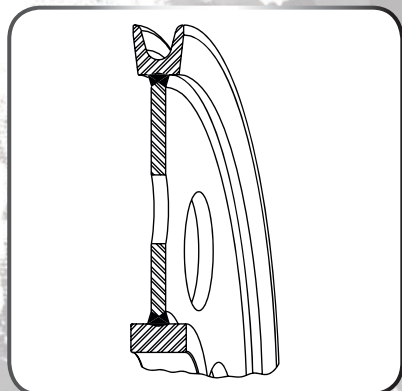

### The Best Solution for Large Sheave Sizes

McKissick fabricated sheaves are available with machined groove rings or machined forged rings utilized for the rim or hub.



### Large Range of Sheave Sizes Available

McKissick fabricated sheaves are available in multiple sizes, and bearing styles that best fit your heavy duty applications.

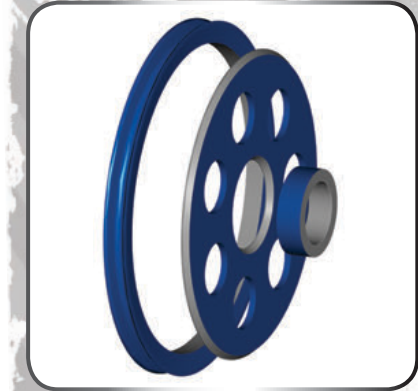

### For Larger Sheave Sizes

McKissick fabricated sheaves are an excellent solution when the required sheave size is too large to be manufactured by the roll forged sheave process.

**MCKISSICK® SHEAVES**

**McKissick® Closed Die Forged Sheaves**

**HEAVY DUTY SHEAVES**  
FROM 102mm THROUGH 305mm

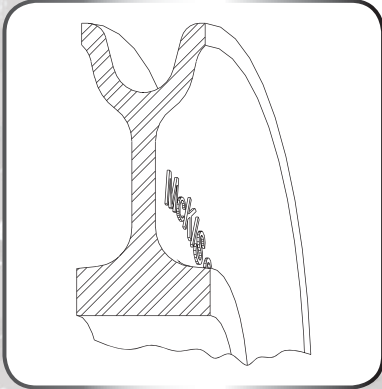

**Closed Die Forging**

McKissick closed die forged sheaves offer the performance of closed die forging with the precision machining capabilities of CNC machinery.

**For Smaller Sheaves in Heavy Duty Application**

McKissick closed die forged sheaves are available in sizes from 102mm to 305mm. An extremely effective solution for heavy duty applications where high loads are applied.

Any of the bearings we offer with the roll forged sheaves are available.



**Select Range of Sheave Sizes Available**

McKissick closed die forged sheaves are available in sizes from 102mm to 305mm, and bearing styles that best fit your heavy duty applications.

**McKissick® Ductile Iron Sheaves**

Custom sheaves are available. See page 287 for ordering details.

**NORMAL SERVICE DUTY SHEAVES**  
FROM 76mm THROUGH 406mm

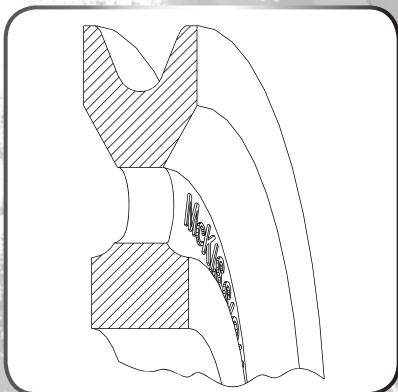

**Machined Ductile Iron**

McKissick ductile iron sheaves are manufactured with material that meets ASTM A-536.

**For Smaller Sheaves in Normal Duty Applications**

McKissick ductile iron sheaves are an acceptable solution for light or normal duty applications where sheaves are protected by sheave guards and minimal side loads are applied.

Standard roller bearings and bronze bushings are typically appropriate for use in these applications.

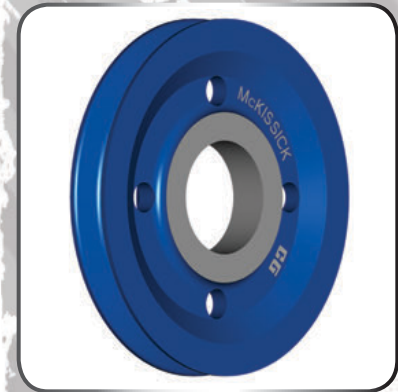

**Select Range of Sheave Sizes Available**

McKissick ductile iron sheaves are available in sizes from 76mm to 406mm, and bearing styles that best fit your normal service duty applications.



## McKISSICK® Wireline GROOVE PROFILES

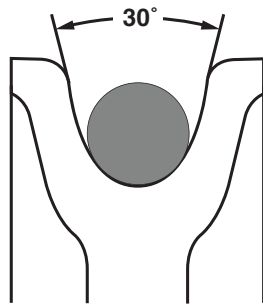

**API STYLE**  
30 degrees

The sheave profile is a very important feature of all sheaves. McKissick manufactures standard sheaves for general use in hoisting Wireline guide applications to minimal API Specifications. The profile includes included groove angle of 30°. This groove profile is used in mobile cranes, drilling rigs, working units, tubing blocks, traveling blocks, crown blocks and many other general hoisting applications.

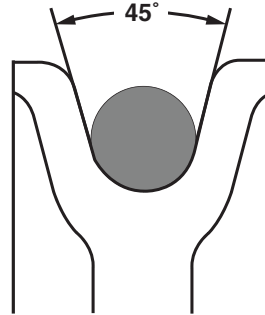

**EUROPEAN STYLE**  
45 degrees

DIN 15061 lifting appliances defines groove profiles for Wireline sheaves.

Nominal tread depth is 1.5 times Wireline diameter.

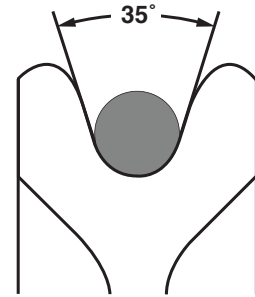

**AISE STYLE**  
35 degrees

McKissick manufactures sheaves to meet the specifications of AISE Standard Number 6. AISE Sheaves must meet specified criteria established by the Association of Iron and Steel Engineers for special use in electric over-head Traveling Cranes for Steel Mill Service. The profile included groove angle of 35°. Dimensional details are also different from the API profile. This groove profile is used in overhead traveling cranes, mobile cranes, portal cranes, power shovels and other equipment using Wireline.

*Contact Crosby for additional available groove angles.*

## McKissick® Sheaves Available to API Standards

- McKissick® Products has been licensed by the American Petroleum Institute to manufacture Roll-Forged Sheaves under API specifications 8C. In addition, McKissick® Products is API Q1 certified.
- McKissick® Products also produces sheaves to the requirements of API 2C.
- API sheaves must meet the criteria established by the American Petroleum Institute for drilling and production hoisting equipment .
- Typical oilfield applications include: Heavy Haul Trucking, Workover and Well Servicing Units, Tubing Blocks, Traveling Blocks, Crown Blocks and Offshore Cranes.

### API 8C Requires

- Databook
- Material certs and traceability
- D/d ratio per API RP9B
- MPI
- UT of full penetration weld
- 30° groove angle. Groove depth a minimum 1.33 d and maximum 1.75 d, where d=nominal rope diameter.
- Manufactured by an API-8C licensed facility
- Specific groove radius
- Can be furnished to API 8C PSL1 or PSL2

### API 2C Requires

- Material certs and traceability
- D/d ratio 18/1 or greater, based on pitch diameter
- At least 30° groove angle
- Specific groove radius



Licensed Under  
API Spec 8C-0021



# McKissick® Sheaves Bearings Application Information

## (B) Bronze Bushing

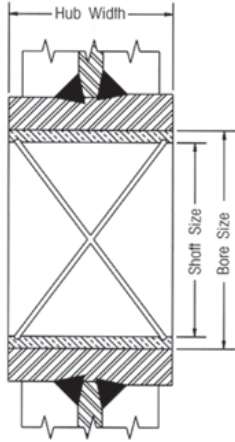

### Bronze Bushing

Slow line speed, moderate load and moderate use

- Maximum Bearing Pressure (BP): 31N/mm<sup>2</sup>
- Maximum Velocity at Bearing (BV): 366m/min
- Maximum Pressure Velocity Factor (PV): 114

$$\text{Formula for BP} = \frac{\text{Line Pull} \times \text{Angle Factor (See Page 383)}}{\text{Shaft Size} \times \text{Hub Width (See example)}}$$



*For underwater sheave applications, special bronze bushings are available. Consult the bearing manufacturer for applicable load.*

### Example:

Using a 356mm sheave (917191) with a 20,000 N line pull and an 80 degree angle between lines, determine maximum allowable line speed.

$$\text{BP} = \frac{\begin{matrix} \text{(Line Pull)} \\ 20,000\text{N} \end{matrix} \times \begin{matrix} \text{(Angle Factor)} \\ 1.53 \end{matrix}}{\begin{matrix} \text{(Shaft Size)} \\ 38 \end{matrix} \times \begin{matrix} \text{(Hub Width)} \\ 41 \end{matrix}} = 19,64\text{N/m}^2$$

$$\text{BV} = \frac{\begin{matrix} \text{(PV Factor)} \\ 114 \end{matrix}}{\begin{matrix} \text{(BP)} \\ 19,64 \end{matrix}} = 5,8\text{m/min}$$

## (R) Roller Bearings

### ROLLER BEARINGS

Bronze Bushings with "Figure 8" oil grooves are made from S.A.E. 660 bronze for cold finished shafts.

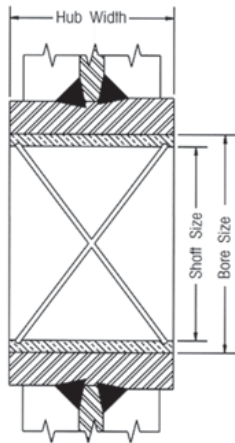

**Roller Bearings** are designed to operate on shafts carburized to 60 Rockwell C and grounded to +/- .0005 of shaft size.

## (W) Roller Bearing with Thrust Washers

### STANDARD STRAIGHT ROLLER BEARINGS

Heavier loads, higher speeds, more frequent use, radial loads only.

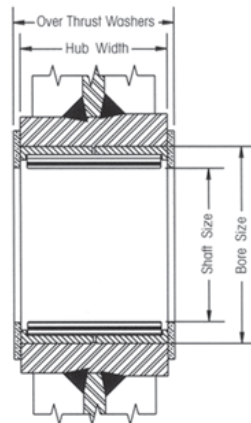

**Roller Bearings** without inner races are designed to operate on shafts carburized to 60 Rockwell C and grounded to +/- .0005 of shaft size.

## (C) Full Complement Cylindrical Roller Bearing

### FULL COMPLEMENT, DOUBLE ROW, ROLLER BEARING

Heavy load, high speeds, continuous operation, axial and radial loads.

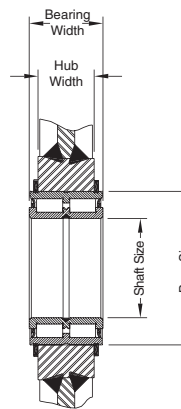

**Cylindrical Roller Bearings** with snap ring grooves are complete units with outer and inner rings, rib guided cylindrical rollers and sealing rings. They can support axial forces in both directions as well as radial forces. They have high dynamic and static load ratings.

## (T) Tapered Roller Bearing

### TAPERED ROLLER BEARINGS

Heavy loads, high speeds, continuous operation, axial and radial loads.

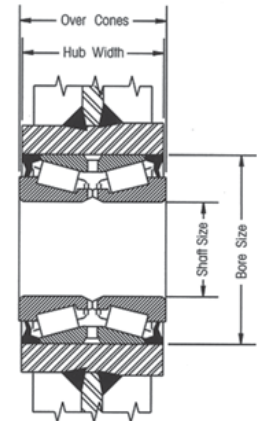

**Tapered Bearings** are designed to operate on shafts machined to +/- .0005 of shaft size. Applications should provide for tightening separator plates against bearing cones to adjust and insure proper function of bearings.

# McKissick® Sheaves Selection Guide



**McKissick® Sheaves** come in a variety of sizes to suit your specific applications. Crosby offers many sheaves as standard and these are shown in the pages that follow.

For applications that require unique specifications, Crosby can make minor modifications to many of the sheaves listed at a reasonable charge. We can also custom design and manufacture sheaves to your exact requirements. Contact Crosby Sales to order McKissick® sheaves and include the stock number and quantity. For help in finding that standard sheave or for help with special requirements or custom designed sheaves, furnish the following important information:

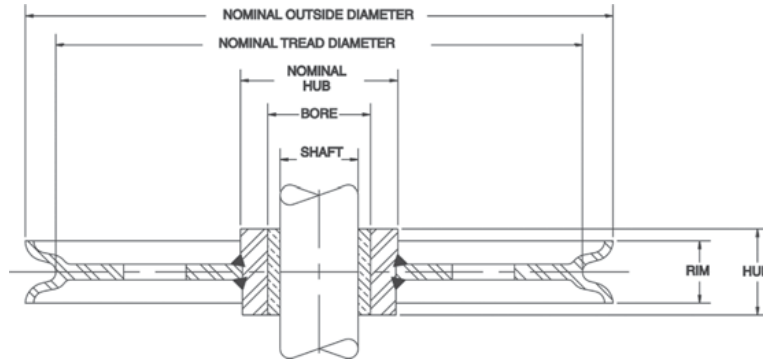

## DIMENSIONAL INFORMATION

Nominal Outside Diameter: \_\_\_\_\_ WireRope Size: \_\_\_\_\_ Rim Width: \_\_\_\_\_

+ Shaft Size: \_\_\_\_\_ \*Hub Width: \_\_\_\_\_

Nominal Tread Diameter (Optional): \_\_\_\_\_ Nominal Hub Diameter (Optional): \_\_\_\_\_

\*Hub width is measured over the cone of the Tapered Bearing Sheaves.

+ Shaft Size is Bore Size on Plain Bore Sheaves.

## BEARING TYPE

Bronze Bushing       ++ Roller Bearing       Tapered Roller Bearing       Finish / Plain Bore

Full Complement Cylindrical Roller Bearing       Underwater       Other

## MATERIAL TYPE

Roll-Forged (Flame hardened 14" and larger)       Forged Steel       Domed

Cast Steel       Fabricated       Other

## APPLICATION INFORMATION

Line Pull: \_\_\_\_\_ Fleet Angle: \_\_\_\_\_ Degree of Wrap: \_\_\_\_\_

Line Speed: \_\_\_\_\_ Environment: \_\_\_\_\_ Groove Angle: \_\_\_\_\_

## SPECIAL REQUIREMENTS

Special Testing: \_\_\_\_\_

Finish: \_\_\_\_\_

Third Party Inspection / Approval: \_\_\_\_\_

In USA: Crosby's Special Engineered Product Group at 1-800-777-1555, fax (918) 834-5035, specials@thecrosbygroup.com

In Canada: Crosby Canada at (905) 451-9261

In Europe: N.V. Crosby Europe at 32 15 757125(26).

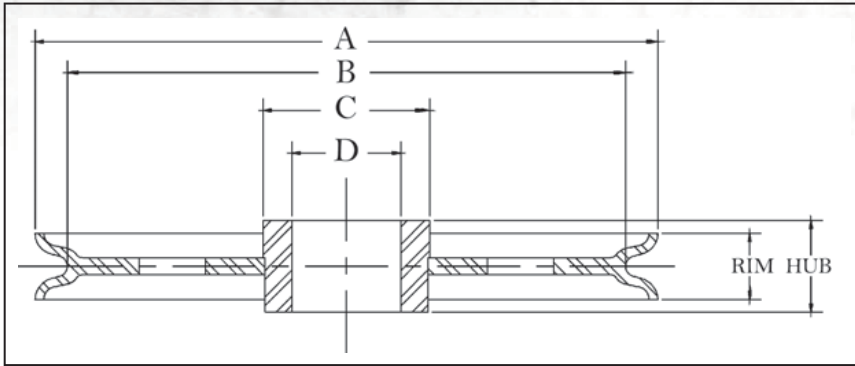

**Finished Bore Sheaves**

- Roll-Forged™ sheaves are available in sizes up to 1981mm diameter.
- McKissick® Finished Bore Sheaves can be equipped with bushings or bearings at an optional charge.
- 356mm diameter sheaves and larger are Roll-Forged with Flame hardened grooves to minimum Rockwell 35C.

"A" Nominal Outside Diameter (mm)	Stock Number	Wire Line Size (mm)	"D" Bore Size (mm)	Hub Width (mm)	Rim Width (mm)	"C" Nominal Hub Outside Diameter (mm)	"B" Nominal Tread Diameter (mm)	Material	Approx. Weight (kg)
76.0	51008	6	19.1	33.3	31.8	28.6	52.5	B.S.	.45
76.0	11310	10	19.1	33.3	31.8	28.6	52.5	B.S.	.45
102	51053	3	39.9	25.4	22.2	51.0	79.5	B.S.	.91
102	51044	6	39.9	25.4	22.2	51.0	79.5	B.S.	.91
102	1189	10	39.9	25.4	22.2	51.0	79.5	B.S.	.91
102	2023185	10	39.9	38.1	34.9	51.0	76.0	F.S.	1.59
102	2023182	13	39.9	38.1	34.9	51.0	76.0	F.S.	1.59
102	2023187	16	39.9	38.1	34.9	51.0	76.0	F.S.	1.59
108	50553	10	20.7	30.2	23.8	54.0	85.5	B.S.	1.09
108	25939	13	20.7	30.2	23.8	54.0	85.5	B.S.	1.09
121	51222	8	22.2	39.7	34.9	38.1	92.0	D.I.	1.59
121	51231	10	22.2	39.7	34.9	38.1	92.0	D.I.	1.59
121	11622	13	22.2	39.7	34.9	38.1	92.0	D.I.	1.59
124	2026411	10	44.4	31.8	28.6	57.0	103	F.S.	1.63
124	62149	10	46.9	33.3	28.6	57.0	103	F.S.	1.13
124	2026413	13	44.4	31.8	28.6	57.0	103	F.S.	1.63
124	2026409	16	44.4	31.8	28.6	57.0	103	F.S.	1.63
127	51071	8	28.6	25.4	22.2	38.1	102	F.S.	1.13
127	51062	10	28.6	25.4	22.2	38.1	102	F.S.	1.13
127	25948	11	28.6	25.4	22.2	38.1	102	F.S.	1.13
133	2026426	16	39.8	38.1	34.9	52.3	98.4	F.S.	1.81
133	2026422	19	39.8	38.1	34.9	52.3	98.4	F.S.	1.81
149	2023133	16	47.6	44.5	41.3	63.5	111	F.S.	2.72
149	2023136	19	47.6	44.5	41.3	63.5	111	F.S.	2.72
149	2023134	22	47.6	44.5	41.3	63.5	111	F.S.	2.72
152	51124	10	41.3	28.6	25.4	57.0	125	F.S.	1.81
152	51375	13	34.9	38.1	31.8	79.5	121	B.S.	3.18
152	13014	13	41.3	28.6	25.4	57.0	125	F.S.	1.81
152	60695	13	60.5	44.5	31.8	79.5	121	F.S.	2.13
152	2023263	16	63.5	58.5	55.5	79.5	108	F.S.	4.31
152	1410	19	34.9	38.1	31.8	79.5	121	B.S.	3.18
152	2023257	19	63.5	58.5	55.5	79.5	108	F.S.	4.31
152	2023261	22	63.5	58.5	55.5	79.5	108	F.S.	4.31
178	61872	6	46.9	33.3	19.1	60.5	159	B.S.	1.81
178	51437	6	47.6	34.9	19.1	60.5	159	B.S.	2.81
178	3203	10	47.6	34.9	19.1	60.5	159	B.S.	2.81
191	2026452	16	39.9	38.1	34.9	52.5	176	F.S.	3.40
191	2026450	19	39.9	38.1	34.9	52.5	160	F.S.	3.40
194	51605	10	39.9	38.1	31.8	60.5	157	D.I.	3.18
194	5498	13	39.9	38.1	31.8	60.5	157	D.I.	3.18
194	51614	16	39.9	38.1	31.8	60.5	157	D.I.	3.18

Custom sheaves are available. See page 287 for ordering details.



# McKissick® Finished Bore Sheaves



"A" Nominal Outside Diameter (mm)	Stock Number	Wireline Size (mm)	"D" Bore Size (mm)	Hub Width (mm)	Rim Width (mm)	"C" Nominal Hub Outside Diameter (mm)	"B" Nominal Tread Diameter (mm)	Material	Approx. Weight (kg)
203	2023466	26	70.0	63.5	60.5	102	133	F.S.	6.80
203	6353	29	70.0	63.5	60.5	102	137	F.S.	6.80
203	2023152	19	47.7	44.5	41.3	65.0	160	F.S.	4.54
203	61710	13	46.9	33.3	31.8	62.0	168	F.S.	3.63
203	51589	13	47.6	38.1	34.9	62.0	168	F.S.	3.18
203	2023144	13	47.7	44.5	41.3	65.0	160	F.S.	4.54
203	51598	16	47.6	38.1	34.9	62.0	168	F.S.	3.18
203	2023146	16	47.7	44.5	41.3	65.0	160	F.S.	4.54
203	5194	19	47.6	38.1	34.9	62.0	168	F.S.	3.18
203	2028226	19	63.5	58.5	54.0	82.5	156	F.S.	5.67
203	2023403	19	65.0	58.5	54.0	82.5	156	F.S.	4.65
203	2023385	19	63.5	58.5	54.0	82.5	156	F.S.	5.67
203	2023765	19	65.0	58.5	54.0	82.5	156	C.S.	4.65
216	61747	10	46.9	33.3	25.4	70.0	191	D.I.	4.99
248	2026492	10	76.0	55.6	25.4	95.5	222	F.S.	4.08
251	51918	10	76.0	44.5	28.6	95.5	217	F.S.	6.35
251	51749	13	34.9	38.1	34.9	82.5	216	F.S.	4.31
251	2023154	13	47.6	44.5	41.3	65.0	211	F.S.	6.58
251	6040	13	76.0	44.5	28.6	95.5	217	B.S.	6.35
251	5675	16	34.9	38.1	34.9	82.5	216	F.S.	4.31
251	2023169	16	47.6	44.5	41.3	65.0	211	F.S.	6.58
251	2023173	19	47.6	44.5	41.3	65.0	211	F.S.	6.58
251	2023435	19	65.0	58.5	55.5	89.0	206	F.S.	7.30
251	2023419	22	63.5	58.5	55.5	89.0	206	F.S.	6.80
251	2023427	26	63.5	58.5	55.5	89.0	206	F.S.	6.80
254	2023484	28	70.0	63.5	60.5	102	187	F.S.	8.62
254	2023784	28	102	63.5	60.5	146	187	F.S.	12.3
302	62096	6	76.0	55.5	25.4	95.5	273	D.I.	5.44
302	6193	10	76.0	58.5	25.4	95.5	273	D.I.	5.08
305	2023247	16	47.7	44.5	41.3	82.5	257	F.S.	8.15
305	2023234	19	47.7	44.5	41.3	82.5	248	F.S.	8.15
305	2023251	22	47.7	44.5	41.3	82.5	260	F.S.	8.15
<b>305</b>	<b>2026531</b>	<b>16</b>	<b>76.0</b>	<b>44.5</b>	<b>41.3</b>	<b>114</b>	<b>257</b>	<b>R.F.</b>	<b>7.26</b>
<b>305</b>	<b>52285</b>	<b>19</b>	<b>76.0</b>	<b>44.5</b>	<b>41.3</b>	<b>114</b>	<b>248</b>	<b>R.F.</b>	<b>7.26</b>
<b>305</b>	<b>2030851</b>	<b>16</b>	<b>63.5</b>	<b>58.5</b>	<b>55.5</b>	<b>114</b>	<b>257</b>	<b>R.F.</b>	<b>10.9</b>
<b>305</b>	<b>2030847</b>	<b>19</b>	<b>63.5</b>	<b>58.5</b>	<b>55.5</b>	<b>114</b>	<b>248</b>	<b>R.F.</b>	<b>10.9</b>
<b>305</b>	<b>60007</b>	<b>19</b>	<b>70.0</b>	<b>58.5</b>	<b>55.5</b>	<b>114</b>	<b>248</b>	<b>R.F.</b>	<b>10.9</b>
<b>305</b>	<b>2026537</b>	<b>19</b>	<b>76.0</b>	<b>55.5</b>	<b>55.5</b>	<b>114</b>	<b>248</b>	<b>R.F.</b>	<b>10.9</b>
<b>305</b>	<b>74724</b>	<b>19</b>	<b>76.0</b>	<b>58.5</b>	<b>55.5</b>	<b>114</b>	<b>248</b>	<b>R.F.</b>	<b>10.9</b>
<b>305</b>	<b>2030842</b>	<b>22</b>	<b>63.5</b>	<b>58.5</b>	<b>55.5</b>	<b>114</b>	<b>260</b>	<b>R.F.</b>	<b>10.9</b>
<b>305</b>	<b>2023553</b>	<b>22</b>	<b>70.0</b>	<b>63.5</b>	<b>60.5</b>	<b>114</b>	<b>260</b>	<b>R.F.</b>	<b>12.7</b>
<b>305</b>	<b>62283</b>	<b>22</b>	<b>76.0</b>	<b>55.5</b>	<b>55.5</b>	<b>114</b>	<b>260</b>	<b>R.F.</b>	<b>10.9</b>
<b>305</b>	<b>4016594</b>	<b>22</b>	<b>76.0</b>	<b>44.5</b>	<b>41.3</b>	<b>114</b>	<b>260</b>	<b>R.F.</b>	<b>10.4</b>
<b>305</b>	<b>2030845</b>	<b>26</b>	<b>63.5</b>	<b>58.5</b>	<b>55.5</b>	<b>102</b>	<b>238</b>	<b>R.F.</b>	<b>10.9</b>
305	2023551	28	70.0	63.5	60.5	114	238	R.F.	10.9
330	33653	10	63.5	38.1	28.6	89.0	295	R.F.	6.35
330	50704	13	63.5	38.1	28.6	89.0	295	R.F.	6.35
356	2023249	16	47.7	44.5	41.3	82.5	308	R.F.	9.07
356	2023243	19	47.7	44.5	41.3	82.5	299	R.F.	9.07
356	2023250	22	47.7	44.5	41.3	82.5	311	R.F.	9.07
356	2023567	22	70.0	63.5	60.5	114	311	R.F.	12.7
356	2023570	26	70.0	63.5	60.5	114	289	R.F.	12.7
356	2023564	28	70.0	63.5	60.5	114	289	R.F.	12.7
356	* 52720	13	108	63.5	34.9	129	321	D.I.	6.80
356	4013098	16	63.5	44.5	41.3	114	308	R.F.	14.1
356	4013187	16	60.5	44.5	41.3	114	308	R.F.	13.6
356	2029220	16	110	55.3	52.5	146	308	R.F.	13.6
356	4013196	19	60.5	44.5	41.3	114	299	R.F.	13.6
356	4013105	19	63.5	44.5	41.3	114	299	R.F.	14.1
356	4016503	19	82.5	58.5	55.5	140	299	R.F.	15.4
356	2029222	19	110	55.3	52.5	146	299	R.F.	14.5

McKissick® Roll-Forged sheaves highlighted above in bold italic are available with reduced lead times due to our advanced manufacturing process.

\*Without flame hardening.

Custom sheaves are available. See page 287 for ordering details.

"A" Nominal Outside Diameter (mm)	Stock Number	Wireline Size (mm)	"D" Bore Size (mm)	Hub Width (mm)	Rim Width (mm)	"C" Nominal Hub Outside Diameter (mm)	"B" Nominal Tread Diameter (mm)	Material	Approx. Weight (kg)
<b>356</b>	<b>4013114</b>	<b>22</b>	<b>63.5</b>	<b>44.5</b>	<b>41.3</b>	<b>114</b>	<b>311</b>	<b>R.F.</b>	<b>13.6</b>
<b>356</b>	<b>52695</b>	<b>22</b>	<b>63.5</b>	<b>58.5</b>	<b>54.0</b>	<b>114</b>	<b>311</b>	<b>R.F.</b>	<b>20.4</b>
<b>406</b>	<b>4010000</b>	<b>13</b>	<b>108</b>	<b>70.0</b>	<b>60.3</b>	<b>146</b>	<b>362</b>	<b>R.F.</b>	<b>20.0</b>
<b>406</b>	<b>4010046</b>	<b>19</b>	<b>108</b>	<b>70.0</b>	<b>63.5</b>	<b>146</b>	<b>340</b>	<b>R.F.</b>	<b>11.3</b>
<b>406</b>	<b>4010171</b>	<b>22</b>	<b>76.0</b>	<b>55.5</b>	<b>55.5</b>	<b>114</b>	<b>329</b>	<b>R.F.</b>	<b>15.9</b>
<b>406</b>	<b>4013294</b>	<b>22</b>	<b>76.0</b>	<b>58.5</b>	<b>55.5</b>	<b>114</b>	<b>329</b>	<b>R.F.</b>	<b>21.3</b>
<b>406</b>	<b>4013258</b>	<b>22</b>	<b>82.5</b>	<b>58.5</b>	<b>55.5</b>	<b>114</b>	<b>329</b>	<b>R.F.</b>	<b>21.3</b>
<b>406</b>	<b>4010126</b>	<b>26</b>	<b>108</b>	<b>70.0</b>	<b>63.5</b>	<b>146</b>	<b>340</b>	<b>R.F.</b>	<b>19.1</b>
<b>432</b>	<b>62559</b>	<b>16</b>	<b>120</b>	<b>70.0</b>	<b>63.5</b>	<b>165</b>	<b>381</b>	<b>R.F.</b>	<b>23.6</b>
<b>457</b>	<b>2026599</b>	<b>19</b>	<b>108</b>	<b>70.0</b>	<b>55.5</b>	<b>165</b>	<b>406</b>	<b>R.F.</b>	<b>24.5</b>
<b>457</b>	<b>4010493</b>	<b>22</b>	<b>89.0</b>	<b>58.7</b>	<b>55.5</b>	<b>140</b>	<b>379</b>	<b>R.F.</b>	<b>29.0</b>
<b>457</b>	<b>2029269</b>	<b>22</b>	<b>155</b>	<b>73.0</b>	<b>66.5</b>	<b>203</b>	<b>379</b>	<b>R.F.</b>	<b>39.0</b>
<b>457</b>	<b>4013490</b>	<b>26</b>	<b>82.5</b>	<b>58.5</b>	<b>55.5</b>	<b>140</b>	<b>378</b>	<b>R.F.</b>	<b>24.0</b>
<b>457</b>	<b>4013524</b>	<b>26</b>	<b>89.0</b>	<b>58.5</b>	<b>55.5</b>	<b>140</b>	<b>378</b>	<b>R.F.</b>	<b>29.0</b>
<b>457</b>	<b>2023608</b>	<b>26</b>	<b>114</b>	<b>76.0</b>	<b>70.0</b>	<b>165</b>	<b>384</b>	<b>R.F.</b>	<b>27.2</b>
<b>457</b>	<b>2023602</b>	<b>28</b>	<b>114</b>	<b>76.0</b>	<b>70.0</b>	<b>165</b>	<b>384</b>	<b>R.F.</b>	<b>27.2</b>
<b>508</b>	<b>*4014024</b>	<b>8</b>	<b>108</b>	<b>70.0</b>	<b>34.9</b>	<b>146</b>	<b>479</b>	<b>R.F.</b>	<b>20.4</b>
<b>508</b>	<b>4010616</b>	<b>19</b>	<b>89.0</b>	<b>58.5</b>	<b>55.5</b>	<b>140</b>	<b>457</b>	<b>R.F.</b>	<b>29.9</b>
<b>508</b>	<b>4010885</b>	<b>19</b>	<b>108</b>	<b>70.0</b>	<b>54.0</b>	<b>165</b>	<b>457</b>	<b>R.F.</b>	<b>36.3</b>
<b>508</b>	<b>2029300</b>	<b>22</b>	<b>155</b>	<b>73.0</b>	<b>66.5</b>	<b>203</b>	<b>430</b>	<b>R.F.</b>	<b>31.8</b>
<b>508</b>	<b>4010634</b>	<b>26</b>	<b>89.0</b>	<b>58.5</b>	<b>55.5</b>	<b>140</b>	<b>419</b>	<b>R.F.</b>	<b>36.7</b>
<b>508</b>	<b>4013613</b>	<b>26</b>	<b>95.0</b>	<b>58.5</b>	<b>55.5</b>	<b>140</b>	<b>419</b>	<b>R.F. 7</b>	<b>34.5</b>
<b>508</b>	<b>2029304</b>	<b>26</b>	<b>155</b>	<b>73.0</b>	<b>66.5</b>	<b>203</b>	<b>419</b>	<b>R.F.</b>	<b>36.3</b>
<b>508</b>	<b>4010625</b>	<b>22</b>	<b>89.0</b>	<b>58.5</b>	<b>55.5</b>	<b>140</b>	<b>430</b>	<b>R.F.</b>	<b>33.6</b>
<b>508</b>	<b>4010901</b>	<b>26</b>	<b>108</b>	<b>70.0</b>	<b>54.0</b>	<b>165</b>	<b>419</b>	<b>R.F.</b>	<b>36.3</b>
<b>610</b>	<b>4012749</b>	<b>14</b>	<b>165</b>	<b>85.5</b>	<b>79.5</b>	<b>203</b>	<b>559</b>	<b>R.F.</b>	<b>67.0</b>
<b>610</b>	<b>*4014408</b>	<b>16</b>	<b>120</b>	<b>70.0</b>	<b>38.1</b>	<b>165</b>	<b>553</b>	<b>R.F.</b>	<b>54.0</b>
<b>610</b>	<b>2026108</b>	<b>22</b>	<b>165</b>	<b>85.5</b>	<b>79.5</b>	<b>203</b>	<b>530</b>	<b>R.F.</b>	<b>58.1</b>
<b>610</b>	<b>4011385</b>	<b>26</b>	<b>76.0</b>	<b>63.5</b>	<b>60.5</b>	<b>114</b>	<b>537</b>	<b>R.F.</b>	<b>56.7</b>
<b>610</b>	<b>4011214</b>	<b>26</b>	<b>114</b>	<b>76.0</b>	<b>70.0</b>	<b>165</b>	<b>537</b>	<b>R.F.</b>	<b>61.2</b>
<b>610</b>	<b>4012785</b>	<b>26</b>	<b>155</b>	<b>73.0</b>	<b>66.5</b>	<b>203</b>	<b>537</b>	<b>R.F.</b>	<b>59.0</b>
<b>610</b>	<b>2025931</b>	<b>26</b>	<b>165</b>	<b>85.5</b>	<b>79.5</b>	<b>203</b>	<b>537</b>	<b>R.F.</b>	<b>56.7</b>
<b>610</b>	<b>4011223</b>	<b>28</b>	<b>114</b>	<b>76.0</b>	<b>70.0</b>	<b>165</b>	<b>510</b>	<b>R.F.</b>	<b>59.0</b>
<b>610</b>	<b>2026646</b>	<b>28</b>	<b>120</b>	<b>70.0</b>	<b>70.0</b>	<b>165</b>	<b>510</b>	<b>R.F.</b>	<b>57.6</b>
<b>610</b>	<b>4012794</b>	<b>28</b>	<b>155</b>	<b>73.0</b>	<b>66.5</b>	<b>203</b>	<b>510</b>	<b>R.F.</b>	<b>54.0</b>
<b>610</b>	<b>2029333</b>	<b>28</b>	<b>165</b>	<b>85.5</b>	<b>79.5</b>	<b>203</b>	<b>510</b>	<b>R.F.</b>	<b>60.0</b>
<b>610</b>	<b>4011410</b>	<b>38</b>	<b>165</b>	<b>85.5</b>	<b>79.5</b>	<b>210</b>	<b>508</b>	<b>R.F.</b>	<b>84.3</b>
<b>762</b>	<b>2026302</b>	<b>22</b>	<b>165</b>	<b>85.5</b>	<b>79.5</b>	<b>203</b>	<b>686</b>	<b>R.F.</b>	<b>84.3</b>
<b>762</b>	<b>2029351</b>	<b>26</b>	<b>165</b>	<b>85.5</b>	<b>79.5</b>	<b>203</b>	<b>686</b>	<b>R.F.</b>	<b>85.0</b>
<b>762</b>	<b>2029375</b>	<b>26</b>	<b>200</b>	<b>89.0</b>	<b>79.5</b>	<b>241</b>	<b>686</b>	<b>R.F.</b>	<b>116</b>
<b>762</b>	<b>2029364</b>	<b>28</b>	<b>165</b>	<b>85.5</b>	<b>79.5</b>	<b>203</b>	<b>686</b>	<b>R.F.</b>	<b>84.3</b>
<b>762</b>	<b>2029378</b>	<b>28</b>	<b>200</b>	<b>89.0</b>	<b>79.5</b>	<b>241</b>	<b>670</b>	<b>R.F.</b>	<b>100</b>
<b>762</b>	<b>2029382</b>	<b>32</b>	<b>200</b>	<b>89.0</b>	<b>79.5</b>	<b>241</b>	<b>670</b>	<b>R.F.</b>	<b>102</b>
<b>762</b>	<b>4011839</b>	<b>38</b>	<b>200</b>	<b>89.0</b>	<b>79.5</b>	<b>241</b>	<b>660</b>	<b>R.F.</b>	<b>111</b>
<b>914</b>	<b>4012222</b>	<b>26</b>	<b>225</b>	<b>92.0</b>	<b>82.5</b>	<b>279</b>	<b>794</b>	<b>R.F.</b>	<b>160</b>
<b>914</b>	<b>4012160</b>	<b>28</b>	<b>165</b>	<b>85.5</b>	<b>79.5</b>	<b>210</b>	<b>819</b>	<b>R.F.</b>	<b>154</b>
<b>914</b>	<b>2027080</b>	<b>28</b>	<b>225</b>	<b>92.0</b>	<b>82.5</b>	<b>279</b>	<b>819</b>	<b>R.F.</b>	<b>140</b>
<b>914</b>	<b>2027967</b>	<b>32</b>	<b>200</b>	<b>89.0</b>	<b>82.5</b>	<b>241</b>	<b>819</b>	<b>R.F.</b>	<b>154</b>
<b>914</b>	<b>2026695</b>	<b>32</b>	<b>225</b>	<b>92.0</b>	<b>82.5</b>	<b>279</b>	<b>819</b>	<b>R.F.</b>	<b>163</b>
<b>914</b>	<b>4012730</b>	<b>38</b>	<b>200</b>	<b>89.0</b>	<b>82.5</b>	<b>241</b>	<b>813</b>	<b>R.F.</b>	<b>137</b>
<b>1067</b>	<b>4015844</b>	<b>38</b>	<b>225</b>	<b>92.0</b>	<b>82.5</b>	<b>279</b>	<b>978</b>	<b>R.F.</b>	<b>209</b>
<b>1067</b>	<b>4015728</b>	<b>28</b>	<b>276</b>	<b>92.0</b>	<b>85.5</b>	<b>318</b>	<b>978</b>	<b>R.F.</b>	<b>201</b>
<b>1067</b>	<b>4015853</b>	<b>32</b>	<b>225</b>	<b>92.0</b>	<b>82.5</b>	<b>279</b>	<b>975</b>	<b>R.F.</b>	<b>209</b>
<b>1067</b>	<b>4015719</b>	<b>32</b>	<b>276</b>	<b>92.0</b>	<b>85.5</b>	<b>318</b>	<b>975</b>	<b>R.F.</b>	<b>201</b>
<b>1219</b>	<b>4016736</b>	<b>52</b>	<b>352</b>	<b>105</b>	<b>95.5</b>	<b>432</b>	<b>1067</b>	<b>R.F.</b>	<b>333</b>
<b>1270</b>	<b>4016745</b>	<b>32</b>	<b>352</b>	<b>105</b>	<b>95.5</b>	<b>432</b>	<b>1175</b>	<b>R.F.</b>	<b>306</b>
<b>1397</b>	<b>4016282</b>	<b>28</b>	<b>165</b>	<b>85.5</b>	<b>76.0</b>	<b>210</b>	<b>1299</b>	<b>R.F.</b>	<b>244</b>
<b>1524</b>	<b>4016754</b>	<b>35</b>	<b>352</b>	<b>105</b>	<b>92.1</b>	<b>432</b>	<b>1410</b>	<b>R.F.</b>	<b>425</b>
<b>60</b>	<b>4016763</b>	<b>38</b>	<b>352</b>	<b>105</b>	<b>92.1</b>	<b>432</b>	<b>1407</b>	<b>R.F.</b>	<b>425</b>
<b>1626</b>	<b>8060983</b>	<b>51</b>	<b>356</b>	<b>152</b>	<b>108</b>	<b>432</b>	<b>1473</b>	<b>R.F.</b>	<b>519</b>
<b>1829</b>	<b>4016772</b>	<b>44</b>	<b>394</b>	<b>105</b>	<b>95.0</b>	<b>483</b>	<b>1702</b>	<b>R.F.</b>	<b>812</b>
<b>1981</b>	<b>2032626</b>	<b>64</b>	<b>422</b>	<b>173</b>	<b>125</b>	<b>533</b>	<b>1813</b>	<b>R.F./F.</b>	<b>998</b>

McKissick® Roll-Forged sheaves highlighted above in bold italic are available with reduced lead times due to our advanced manufacturing process.  
 \*Without flame hardening groove.

Custom sheaves are available. See page 287 for ordering details.

# McKissick® Common Bore Sheaves

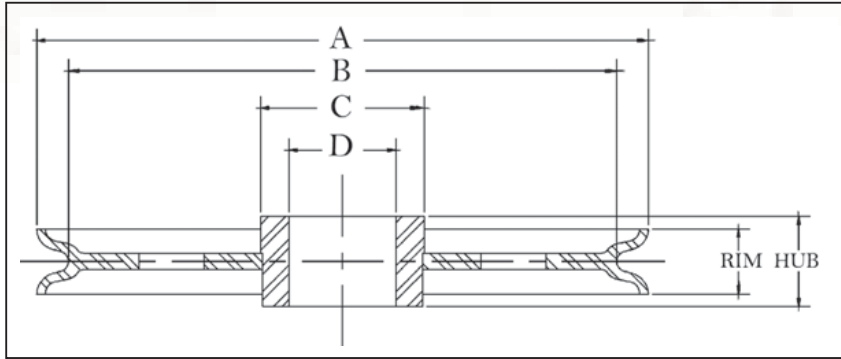

## Common Bore Sheaves

- Roll-Forged sheaves are available in sizes up to 1981mm diameter.
- Common Bore or Plain Bore are terms used when there is merely a hole bored in the center of the sheave.
- Common Bore Sheaves are machined for a running fit for the shaft size listed.

"A" Nominal Outside Diameter (mm)	Stock Number	Wireline Size (mm)	"D" Bore Size (mm)	Hub Width (mm)	Rim Width (mm)	"C" Nominal Hub Outside Diameter (mm)	"B" Nominal Tread Diameter (mm)	Material	Approx. Weight (kg)
76.0	905051	5	9.55	19.8	19.1	25.4	60.5	P.M.	.45
76.0	905079	5	12.7	19.8	19.1	25.4	60.5	P.M.	.45
76.0	905097	5	15.9	19.8	19.1	25.4	60.5	P.M.	.45
76.0	905024	6	9.55	12.7	12.7	25.4	66.5	P.M.	.34
76.0	905042	6	12.7	12.7	12.7	25.4	66.5	P.M.	.34
76.0	15410	10	9.55	19.8	19.1	25.4	60.5	P.M.	.45
76.0	905088	10	12.7	19.8	19.1	25.4	60.5	P.M.	.45
76.0	905104	10	15.9	19.8	19.1	25.4	60.5	P.M.	.27
102	905113	5	12.7	19.1	15.9	34.9	89.0	P.M.	.45
102	905131	5	15.9	19.1	15.9	34.9	89.0	P.M.	.45
102	905122	8	12.7	19.1	15.9	34.9	89.0	P.M.	.45
102	905140	8	15.9	19.1	15.9	34.9	89.0	P.M.	.45
102	905168	10	12.7	20.6	19.1	38.1	82.5	P.M.	.57
102	905186	10	15.9	20.6	19.1	38.1	82.5	P.M.	.57
102	905202	10	19.1	20.6	19.1	38.1	82.5	P.M.	.57
102	905220	13	12.7	27.0	25.4	41.3	81.0	P.M.	.68
102	905248	13	15.9	27.0	25.4	41.3	81.0	P.M.	.68
102	905266	13	19.1	27.0	25.4	41.3	81.0	P.M.	.68
127	905275	5	15.9	23.8	22.2	57.0	108	P.M.	1.02
127	905293	5	19.1	23.8	22.2	57.0	108	P.M.	1.02
127	905284	10	15.9	23.8	22.2	57.0	108	P.M.	1.25
127	905300	10	19.1	23.8	22.2	57.0	108	P.M.	1.02
127	905328	13	15.9	27.0	25.4	57.0	102	P.M.	1.13
127	905364	13	15.9	30.2	28.6	57.0	102	D.I.	1.81
127	905346	13	19.1	27.0	25.4	57.0	102	P.M.	1.13
127	905382	13	19.1	30.2	28.6	57.0	102	D.I.	1.81
127	905408	13	22.2	30.2	28.6	57.0	102	D.I.	1.81
152	905426	10	12.7	20.6	19.1	47.6	127	D.I.	1.13
152	905480	10	12.7	27.0	25.4	47.6	127	D.I.	1.13
152	905462	10	15.9	20.6	19.1	47.6	127	P.M.	1.13
152	905523	10	19.1	27.0	25.4	47.6	127	P.M.	1.89
152	909020	13	22.2	27.0	25.4	47.6	124	P.M.	1.70
152	909066	16	19.1	33.3	31.8	47.6	121	P.M.	1.70
152	909084	16	22.2	33.3	31.8	47.6	121	P.M.	1.70
152	909100	16	25.4	33.3	31.8	47.6	121	P.M.	1.70
152	909164	19	25.4	39.7	38.1	76.2	117	P.M.	3.06
171	905694	6	19.1	30.2	28.6	51.0	149	D.I.	2.27
171	905710	6	25.4	30.2	28.6	51.0	149	D.I.	2.27
171	905701	10	19.1	30.2	28.6	51.0	149	D.I.	2.27
171	905729	10	25.4	30.2	28.6	51.0	149	D.I.	2.27
178	905621	13	19.1	27.0	25.4	51.0	140	D.I.	2.38
178	905649	13	22.2	27.0	25.4	51.0	140	D.I.	2.38
203	905747	13	19.1	28.6	25.4	60.5	175	D.I.	2.27
203	905765	13	22.2	28.6	25.4	60.5	175	D.I.	2.27
203	905783	13	25.4	28.6	25.4	60.5	175	D.I.	3.86

Custom sheaves are available. See page 287 for ordering details.



## McKissick® Common Bore Sheaves

"A" Nominal Outside Diameter (mm)	Stock Number	Wireline Size (mm)	"D" Bore Size (mm)	Hub Width (mm)	Rim Width (mm)	"C" Nominal Hub Outside Diameter (mm)	"B" Nominal Tread Diameter (mm)	Material	Approx. Weight (kg)
203	905809	16	19.1	34.9	31.8	51.0	165	D.I.	2.72
203	905827	16	22.2	34.9	31.8	51.0	165	D.I.	3.06
203	909306	16	22.2	34.9	31.8	63.5	168	D.I.	3.86
203	905845	16	25.4	34.9	31.8	51.0	165	D.I.	3.06
203	909324	16	25.4	34.9	31.8	63.5	168	D.I.	3.86
203	909342	16	28.6	34.9	31.8	63.5	168	D.I.	3.86
203	909360	16	31.8	34.9	31.8	63.5	168	D.I.	3.86
203	909388	16	38.1	34.9	31.8	63.5	168	D.I.	3.86
254	905925	13	22.2	28.6	25.4	73.0	222	D.I.	4.54
254	905943	13	25.4	28.6	25.4	73.0	222	D.I.	4.54
254	905961	16	19.1	34.9	31.8	51.0	216	D.I.	4.20
254	905989	16	22.2	34.9	31.8	51.0	216	D.I.	4.20
254	909681	16	22.2	34.9	31.8	76.0	216	D.I.	6.12
254	906005	16	25.4	34.9	31.8	76.0	216	D.I.	4.20
254	909761	16	38.1	34.9	31.8	76.0	216	D.I.	6.12
305	906041	13	25.4	28.6	25.4	102	270	D.I.	7.48
305	906087	13	31.8	28.6	25.4	102	270	D.I.	7.48
305	906121	19	25.4	41.3	38.1	70.0	260	D.I.	8.28
305	910107	19	25.4	41.3	38.1	133	260	D.I.	11.6
305	906149	19	28.6	41.3	38.1	70.0	260	D.I.	8.28
305	910125	19	28.6	41.3	38.1	133	260	D.I.	11.6
305	906167	19	31.8	41.3	38.1	70.0	260	D.I.	8.28
305	910143	19	31.8	41.3	38.1	133	260	D.I.	11.6
305	910161	19	38.1	41.3	38.1	133	260	D.I.	11.6
305	906229	22	31.8	51.0	44.5	95.5	254	D.I.	9.19
305	906247	22	38.1	51.0	44.5	95.5	254	D.I.	9.19
356	*906283	19	28.6	41.3	38.1	82.5	311	C.I.	12.0
356	*906309	19	31.8	41.3	38.1	82.5	311	C.I.	12.0
356	*910456	22	38.1	41.3	38.1	89.0	308	C.I.	15.4
356	*910447	22	31.8	41.3	38.1	89.0	308	C.I.	15.4
<b>406</b>	<b>910713</b>	<b>26</b>	<b>51.0</b>	<b>51.0</b>	<b>44.5</b>	<b>114</b>	<b>346</b>	<b>R.F.</b>	<b>21.3</b>
<b>406</b>	<b>910697</b>	<b>26</b>	<b>38.1</b>	<b>51.0</b>	<b>44.5</b>	<b>114</b>	<b>346</b>	<b>R.F.</b>	<b>21.3</b>
<b>457</b>	<b>910820</b>	<b>26</b>	<b>51.0</b>	<b>51.0</b>	<b>47.6</b>	<b>102</b>	<b>378</b>	<b>R.F.</b>	<b>28.1</b>

Material: B.S.B ar Steel, C.I.€ ast Iron, F.S.F orged Steel, D.I.Ð uctile Iron, C.S.€ ast Steel, P.M.P owdered Metal, R.F.R oll-Forged.  
 McKissick® Roll-Forged sheaves highlighted above in bold italic are available with reduced lead times due to our advanced manufacturing process.  
 \*Without flame hardening groove.

# McKissick® Bronze Bushed Sheaves

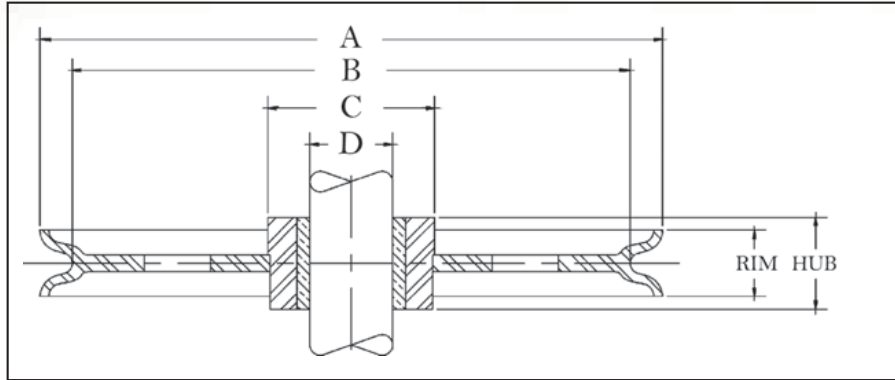

**SEE APPLICATION AND WARNING INFORMATION**  
 On Pages 381 - 388  
 Para Español: [www.thecrosbygroup.com](http://www.thecrosbygroup.com)

## Bronze Bushed Sheaves

- Roll-Forged sheaves are available in sizes up to 1981mm diameter.
- McKissick® Bronze Bushed Sheaves are equipped with S.A.E. 660 Bronze Bushings for cold finished shafts with "Figure 8" oil groove.
- For sizes not listed, McKissick Finished Bore Sheaves can be equipped with bronze bushings at an optional charge.

"A" Nominal Outside Diameter (mm)	Stock Number	Wireline Size (mm)	"D" Shaft Size (mm)	Hub Width (mm)	Rim Width (mm)	"C" Nominal Hub Outside Diameter (mm)	"B" Nominal Tread Diameter (mm)	Material	Approx. Weight (kg)
57.0	907004	6	9.55*	15.9	14.3	19.1	47.6	B.S.	.34
76.0	907059	5	9.55*	19.8	19.1	25.4	60.5	P.M.	.45
76.0	907077	5	12.7*	19.8	19.1	25.4	60.5	P.M.	.45
76.0	907095	5	15.9*	19.8	19.1	25.4	60.5	P.M.	.45
76.0	907022	6	9.55*	12.7	12.7	25.4	66.5	P.M.	.34
76.0	907040	6	12.7*	12.7	12.7	25.4	66.5	P.M.	.34
76.0	460165	6	12.7*	33.3	30.0	28.6	52.5	B.S.	.45
76.0	2030896	8	19.1	25.4	22.2	44.5	57.0	P.M.	.68
76.0	907068	10	9.55*	19.1	19.1	25.4	60.5	P.M.	.45
76.0	916101	10	9.55*	19.8	19.1	38.1	60.5	B.S.	.45
76.0	907086	10	12.7*	19.1	19.1	25.4	60.5	P.M.	.45
76.0	916110	10	12.7*	19.8	19.1	38.1	60.5	B.S.	.45
76.0	460156	10	12.7	33.3	30.0	28.6	52.5	B.S.	.45
76.0	907102	10	15.9*	19.1	19.1	25.4	60.5	P.M.	.45
76.0	2030895	10	19.1	25.4	22.2	44.5	57.0	P.M.	.68
76.0	2023202	11	19.1	25.4	22.2	44.5	57.0	P.M.	.68
76.0	916129	13	9.55*	31.8	28.6	47.6	51.0	B.S.	.60
76.0	916138	13	12.7*	31.8	28.6	47.6	51.0	B.S.	.68
102	460290	3	25.4	25.4	22.2	51.0	79.5	B.S.	.91
102	907111	5	12.7*	19.1	15.9	34.9	89.0	P.M.	.45
102	907139	5	15.9*	19.1	15.9	34.9	89.0	P.M.	.45
102	916147	6	12.7*	20.6	19.1	51.0	82.5	B.S.	.68
102	916165	6	19.1*	20.6	19.1	51.0	82.5	B.S.	.68
102	460307	6	25.4	25.4	22.2	51.0	79.5	B.S.	.91
102	907120	8	12.7*	19.1	15.9	34.9	89.0	P.M.	.45
102	907148	8	15.9*	19.1	15.9	34.9	89.0	P.M.	.45
102	907166	10	12.7*	20.6	19.1	38.1	82.5	P.M.	.57
102	916156	10	12.7*	20.6	19.1	51.0	82.5	B.S.	.68
102	907184	10	15.9*	20.6	19.1	38.1	82.5	P.M.	.64
102	907200	10	19.1*	20.6	19.1	38.1	82.5	P.M.	.57
102	460316	10	25.4	25.4	22.2	51.0	79.5	B.S.	.91
102	907228	13	12.7*	27.0	25.4	41.3	81.0	P.M.	.68
102	916192	13	12.7*	28.6	25.4	41.3	81.0	B.S.	.91
102	907246	13	15.9*	27.0	25.4	41.3	81.0	P.M.	.68
102	907264	13	19.1*	27.0	25.4	41.3	81.0	P.M.	.68
102	2028640	10	19.1*	20.6	19.1	51.0	82.5	B.S.	.68
105	2023186	10	25.4	38.1	34.9	51.0	76.0	F.S.	1.59
105	2029618	13	25.4	38.1	34.9	51.0	76.0	F.S.	1.59
105	2023188	16	25.4	38.1	34.9	51.0	76.0	F.S.	1.59
108	460450	10	15.9*	30.2	23.8	54.0	85.5	B.S.	1.09
108	460441	13	15.9*	30.2	23.8	54.0	85.5	B.S.	1.09
121	460575	8	15.9	39.7	34.9	38.1	92.0	D.I.	1.59
121	460584	10	15.9	39.7	34.9	38.1	92.0	D.I.	1.59
121	460593	13	15.9	39.7	34.9	38.1	92.0	D.I.	1.59

Custom sheaves are available. See page 287 for ordering details.

## McKissick® Bronze Bushed Sheaves

"A" Nominal Outside Diameter (mm)	Stock Number	Wireline Size (mm)	"D" Shaft Size (mm)	Hub Width (mm)	Rim Width (mm)	"C" Nominal Hub Outside Diameter (mm)	"B" Nominal Tread Diameter (mm)	Material	Approx. Weight (kg)
124	460478	10	31.8	31.8	28.6	57.0	103	F.S.	1.63
124	2026414	13	31.8	31.8	28.6	57.0	103	F.S.	1.63
124	460469	16	31.8	31.8	28.6	57.0	103	F.S.	1.63
127	907273	5	15.9*	23.8	22.2	57.0	108	P.M.	1.02
127	907291	5	19.1*	23.8	22.2	57.0	108	P.M.	1.02
127	460511	8	19.1	25.4	22.2	38.1	102	F.S.	1.13
127	907282	10	15.9*	23.8	22.2	57.0	108	P.M.	1.02
127	907308	10	19.1*	23.8	22.2	57.0	108	P.M.	1.02
127	460520	10	19.1	25.4	22.2	38.1	102	F.S.	1.13
127	460539	11	19.1	25.4	22.2	38.1	102	F.S.	1.13
127	907326	13	15.9*	27.0	25.4	57.0	102	P.M.	1.13
127	907362	13	15.9*	30.2	28.6	57.0	102	D.I.	1.81
127	907344	13	19.1*	30.2	25.4	57.0	102	P.M.	1.13
127	907380	13	19.1*	30.2	28.6	57.0	102	D.I.	1.81
127	907406	13	22.2*	30.2	28.6	57.0	102	D.I.	1.81
133	460628	16	25.4	38.1	34.9	52.5	98.5	F.S.	1.81
133	460637	19	25.4	38.1	34.9	52.5	98.5	F.S.	1.81
149	2023129	16	38.1	44.5	41.3	63.5	111	F.S.	2.72
149	2023137	19	38.1	44.5	41.3	63.5	111	F.S.	2.72
149	2023135	22	38.1	44.5	41.3	63.5	111	F.S.	2.72
152	907424	10	12.7*	20.6	19.1	47.6	127	P.M.	1.13
152	907488	10	12.7*	27.0	25.4	47.6	127	P.M.	1.13
152	907442	10	15.9*	20.6	19.1	47.6	127	P.M.	1.13
152	907503	10	15.9*	27.0	25.4	47.6	127	P.M.	1.13
152	907460	10	19.1*	20.6	19.1	47.6	127	P.M.	1.13
152	907521	10	19.1*	27.0	25.4	47.6	127	P.M.	1.13
152	2026483	10	19.1*	27.0	25.4	51.0	130	F.S.	1.81
152	916245	10	22.2*	27.0	25.4	51.0	130	F.S.	1.81
152	2028641	10	25.4*	27.0	25.4	51.0	130	F.S.	1.81
152	460682	10	31.8	28.4	25.4	57.0	125	F.S.	1.68
152	907549	13	15.9*	30.2	28.6	47.6	124	P.M.	2.27
152	907567	13	19.1*	30.2	28.6	47.6	124	P.M.	2.14
152	913024	13	22.2*	27.0	25.4	47.6	124	P.M.	1.70
152	460879	13	25.4	38.1	31.8	79.5	121	B.S.	3.18
152	460673	13	31.8*	28.6	25.4	57.0	125	F.S.	1.81
152	2028048	13	25.4*	27.0	25.4	47.6	124	P.M.	4.31
152	2026938	16	19.1*	27.0	25.4	51.0	130	F.S.	3.18
152	913060	16	19.1*	33.3	31.8	47.6	121	P.M.	1.81
152	916254	16	22.2*	27.0	25.4	51.0	130	F.S.	1.81
152	913088	16	22.2	33.3	31.8	47.6	121	P.M.	1.70
152	2026822	16	25.4*	27.0	25.4	51.0	130	F.S.	1.81
152	913104	16	25.4*	33.3	31.8	47.6	121	P.M.	1.70
152	2023264	16	51.0	58.5	55.5	79.5	108	F.S.	4.31
152	460897	19	25.4	38.1	31.8	79.5	121	B.S.	3.18
152	913168	19	25.4	39.7	38.1	76.0	117	P.M.	3.06
152	2023260	19	51.0	58.5	55.5	79.5	108	F.S.	4.31
152	2023262	22	51.0	58.5	55.5	79.5	108	F.S.	4.31
171	907692	6	19.1*	30.2	28.6	51.0	149	D.I.	2.27
171	907718	6	25.4*	30.2	28.6	51.0	149	D.I.	2.27
171	907709	10	19.1*	30.2	28.6	51.0	149	D.I.	2.27
171	907727	10	25.4*	30.2	28.6	51.0	149	D.I.	2.27
178	461020	6	38.1	34.9	19.1	60.5	159	B.S.	2.81
178	461039	10	38.1	34.9	19.1	60.5	159	B.S.	2.81
178	907629	13	19.1*	27.0	25.4	51.0	143	D.I.	1.93
178	907647	13	22.2*	27.0	25.4	51.0	143	D.I.	1.93
191	460986	16	25.4	38.1	34.9	52.5	160	F.S.	3.40
191	460977	19	25.4	38.1	34.9	52.5	160	F.S.	3.40
194	461262	10	25.4	38.1	31.8	60.5	157	D.I.	3.18
194	461280	13	25.4	38.1	31.8	60.5	157	D.I.	3.18
194	461271	16	25.4	38.1	31.8	60.5	157	D.I.	3.18

Custom sheaves are available. See page 287 for ordering details.



# McKissick® Bronze Bushed Sheaves



"A" Nominal Outside Diameter (mm)	Stock Number	Wireline Size (mm)	"D" Shaft Size (mm)	Hub Width (mm)	Rim Width (mm)	"C" Nominal Hub Outside Diameter (mm)	"B" Nominal Tread Diameter (mm)	Material	Approx. Weight (kg)
203	2023467	26	57.0	63.5	60.3	114	137	F.S.	8.16
203	2023463	28	57.0	63.5	60.3	114	137	F.S.	8.16
203	2023153	19	38.1	44.5	41.3	65.0	160	F.S.	4.54
203	907745	13	19.1*	28.6	25.4	60.5	175	D.I.	2.27
203	916487	13	19.1*	34.9	31.8	51.0	168	F.S.	3.18
203	907763	13	22.2*	28.6	25.4	60.5	175	D.I.	2.27
203	916502	13	22.2*	34.9	31.8	51.0	168	F.S.	3.18
203	907781	13	25.4*	28.6	25.4	60.5	175	D.I.	2.27
203	916520	13	25.4*	34.9	31.8	51.0	168	F.S.	3.18
203	2026841	13	28.6*	34.9	31.8	51.0	168	F.S.	3.18
203	2026844	13	31.8*	34.9	31.8	51.0	168	F.S.	3.18
203	461235	13	38.1	38.1	34.9	62.0	168	F.S.	3.18
203	2023145	13	38.1	44.5	41.3	65.0	160	F.S.	4.54
203	907807	16	19.1*	34.9	31.8	51.0	165	D.I.	3.06
203	913300	16	22.2*	34.9	31.8	51.0	165	D.I.	3.06
203	913328	16	25.4*	34.9	31.8	63.5	168	D.I.	3.86
203	913346	16	28.6*	34.9	31.8	63.5	168	D.I.	3.86
203	913364	16	31.8*	34.9	31.8	63.5	168	D.I.	3.86
203	913382	16	38.1*	34.9	31.8	63.5	168	D.I.	3.86
203	461244	16	38.1	38.1	34.9	62.0	168	F.S.	3.18
203	2023147	16	38.1	44.5	41.3	65.0	160	F.S.	4.54
203	461253	19	38.1	38.1	34.9	62.0	168	F.S.	3.18
203	2028227	19	51.0	58.5	54.0	82.5	156	F.S.	5.67
203	461397	19	70.0	58.5	55.5	95.5	152	R.F.	4.76
203	2023386	22	51.0	58.5	54.0	82.5	156	F.S.	5.67
203	461501	32	89.0	63.5	60.5	127	138	C.S.	6.80
251	462831	10	63.5	44.5	28.6	95.0	217	F.S.	6.35
251	462154	13	25.4*	38.1	34.9	82.5	216	F.S.	4.31
251	2023166	13	38.1	44.5	41.3	65.0	211	F.S.	6.58
251	462840	13	63.5	44.5	28.6	95.5	217	F.S.	6.35
251	462163	16	25.4*	38.1	34.9	82.5	216	F.S.	4.31
251	2023170	16	38.1	44.5	41.3	65.0	211	F.S.	6.58
251	2023174	19	38.1	44.5	41.3	65.0	211	F.S.	6.58
251	2023420	22	51.0	58.5	55.5	89.0	206	F.S.	6.80
251	2023428	25	51.0	58.5	55.5	89.0	206	F.S.	6.80
254	2026861	28	57.0	63.5	60.5	114	187	F.S.	12.3
254	2023785	28	89.0	63.5	60.5	146	187	F.S.	12.7
254	907923	13	22.2*	28.6	25.4	73.0	222	D.I.	4.54
254	907941	13	25.4*	28.6	25.4	73.0	222	D.I.	5.35
254	907969	16	19.1*	34.9	31.8	51.0	216	D.I.	4.20
254	916717	16	22.2*	34.9	31.8	70.0	216	F.S.	4.54
254	913685	16	22.2*	34.9	31.8	76.0	216	D.I.	6.12
254	908003	16	25.4*	34.9	31.8	51.0	216	D.I.	4.20
254	916726	16	25.4*	34.9	31.8	70.0	216	F.S.	6.35
254	2027291	16	31.8*	34.9	31.8	70.0	216	F.S.	6.35
254	913765	16	38.1*	34.9	31.8	76.0	216	D.I.	5.72
254	913863	19	38.1*	41.3	38.1	89.0	210	F.S.	7.26
254	916824	19	31.8*	41.3	38.1	89.0	197	F.S.	7.71
254	913845	19	31.8*	41.3	38.1	89.0	210	F.S.	7.26
254	916833	19	38.1*	41.3	38.1	82.5	197	F.S.	7.71
254	913807	19	25.4*	41.3	38.1	89.0	210	F.S.	7.26
302	462323	10	63.5	58.7	25.4	95.5	273	D.I.	5.08
305	2023227	16	38.1	44.5	41.3	82.5	260	F.S.	9.98
305	2023235	19	38.1	44.5	41.3	82.5	238	F.S.	9.98
305	2023252	22	38.1	44.5	41.3	82.5	260	F.S.	9.98
<b>305</b>	<b>462564</b>	<b>16</b>	<b>63.5</b>	<b>44.5</b>	<b>41.3</b>	<b>114</b>	<b>271</b>	<b>R.F.</b>	<b>10.9</b>
<b>305</b>	<b>462573</b>	<b>19</b>	<b>63.5</b>	<b>44.5</b>	<b>41.3</b>	<b>114</b>	<b>238</b>	<b>R.F.</b>	<b>10.9</b>
305	908049	13	25.4*	28.6	25.4	102	270	D.I.	7.48
305	908085	13	31.8*	28.6	25.4	102	270	D.I.	7.48
305	917002	16	25.4*	41.3	38.1	82.5	257	F.S.	8.16
305	917011	16	28.6*	41.3	38.1	82.5	257	F.S.	8.16
<b>305</b>	<b>462387</b>	<b>16</b>	<b>51.0*</b>	<b>58.5</b>	<b>55.5</b>	<b>114</b>	<b>257</b>	<b>R.F.</b>	<b>11.8</b>
305	908129	19	25.4*	41.3	38.1	70.0	260	D.I.	8.28
305	908147	19	28.6	41.3	38.1	70.0	260	D.I.	8.28
305	914121	19	28.6*	41.3	38.1	133	260	D.I.	11.6

McKissick® Roll-Forged sheaves highlighted above in bold italic are available with reduced lead times due to our advanced manufacturing process. \*Self-lubricating bushing.

Custom sheaves are available. See page 287 for ordering details.

# McKissick® Bronze Bushed Sheaves

"A" Nominal Outside Diameter (mm)	Stock Number	Wireline Size (mm)	"D" Shaft Size (mm)	Hub Width (mm)	Rim Width (mm)	"C" Nominal Hub Outside Diameter (mm)	"B" Nominal Tread Diameter (mm)	Material	Approx. Weight (kg)
305	914149	19	31.8	41.3	38.1	133	260	D.I.	11.6
305	914167	19	38.1	41.3	38.1	133	260	D.I.	11.6
305	<b>346593</b>	19	<b>57.0</b>	<b>58.5</b>	<b>55.5</b>	<b>114</b>	<b>248</b>	<b>R.F.</b>	<b>11.8</b>
305	<b>4104882</b>	19	<b>63.5</b>	<b>44.5</b>	<b>41.3</b>	<b>114</b>	<b>248</b>	<b>R.F.</b>	<b>11.3</b>
305	<b>462449</b>	19	<b>51.0</b>	<b>58.5</b>	<b>55.5</b>	<b>114</b>	<b>248</b>	<b>R.F.</b>	<b>11.8</b>
305	<b>4104917</b>	19	<b>63.5*</b>	<b>58.5</b>	<b>55.5</b>	<b>114</b>	<b>248</b>	<b>R.F.</b>	<b>11.3</b>
305	<b>462485</b>	19	<b>76.0*</b>	<b>76.0</b>	<b>47.6</b>	<b>140</b>	<b>238</b>	<b>R.F.</b>	<b>9.53</b>
305	908227	22	31.8	51.0	44.5	95.5	254	D.I.	9.19
305	908245	22	38.1	51.0	44.5	95.5	254	D.I.	9.19
305	<b>462458</b>	22	<b>51.0</b>	<b>58.5</b>	<b>55.5</b>	<b>114</b>	<b>260</b>	<b>R.F.</b>	<b>11.8</b>
305	<b>2023554</b>	22	<b>57.0</b>	<b>63.5</b>	<b>60.5</b>	<b>114</b>	<b>238</b>	<b>R.F.</b>	<b>12.7</b>
305	<b>4104891</b>	22	<b>63.5</b>	<b>44.5</b>	<b>41.3</b>	<b>114</b>	<b>260</b>	<b>R.F.</b>	<b>11.3</b>
305	<b>462467</b>	25	<b>51.0</b>	<b>58.5</b>	<b>55.5</b>	<b>102</b>	<b>254</b>	<b>R.F.</b>	<b>11.8</b>
305	2023552	32	57.0	63.5	60.5	114	238	R.F.	11.8
<b>330</b>	<b>462779</b>	<b>10</b>	<b>51.0</b>	<b>38.1</b>	<b>28.6</b>	<b>89.0</b>	<b>295</b>	<b>R.F.</b>	<b>6.35</b>
330	462788	13	51.0	38.1	28.6	89.0	295	R.F.	6.35
<b>356</b>	<b>463625</b>	<b>16</b>	<b>38.1</b>	<b>44.5</b>	<b>41.3</b>	<b>89.0</b>	<b>308</b>	<b>R.F.</b>	<b>9.07</b>
356	463634	19	38.1	44.5	41.3	82.5	289	R.F.	9.07
356	463643	22	38.1	44.5	41.3	82.5	289	R.F.	9.07
356	463448	22	57.0	63.5	60.5	82.5	311	R.F.	12.7
356	463457	25	57.0	63.5	60.5	114	289	R.F.	12.7
356	463466	32	57.0	63.5	60.5	114	289	R.F.	12.7
356	<b>**463518</b>	<b>13</b>	<b>95.5*</b>	<b>63.5</b>	<b>34.9</b>	<b>114</b>	<b>321</b>	<b>R.F.</b>	<b>6.80</b>
356	<b>4103552</b>	<b>16</b>	<b>51.0*</b>	<b>44.5</b>	<b>41.3</b>	<b>129</b>	<b>308</b>	<b>R.F.</b>	<b>13.2</b>
356	<b>**908281</b>	19	<b>28.6*</b>	41.3	36.3	114	311	C.I.	12.0
356	<b>**908307</b>	19	<b>31.8*</b>	41.3	38.1	82.5	311	C.I.	12.0
356	917173	19	31.8	41.3	38.1	82.5	305	R.F.	12.0
356	917191	19	38.1	41.3	38.1	102	298	R.F.	12.0
356	4103632	19	51.0*	44.5	41.3	82.5	298	R.F.	13.6
356	4104828	19	70.0*	58.5	55.5	114	298	R.F.	15.9
356	917182	22	31.8*	41.3	38.1	89.0	305	R.F.	12.0
356	917208	22	38.1	41.3	38.1	89.0	305	R.F.	12.0
356	463484	22	51.0	58.5	54.0	102	289	R.F.	12.7
356	4103641	22	51.0	44.5	41.3	114	311	R.F.	14.1
406	4101395	13	89.0	70.0	63.5	146	362	R.F.	24.5
406	4100047	19	89.0	70.0	63.5	146	340	R.F.	21.3
406	4100109	19	95.5	70.0	63.5	146	340	R.F.	19.1
406	4103703	22	63.5*	58.5	55.5	114	329	R.F.	15.9
406	4105211	22	70.0*	58.5	55.5	114	329	R.F.	19.1
406	917342	25	38.1*	51.0	44.5	108	337	R.F.	15.4
406	917360	25	38.1*	51.0	44.5	108	337	R.F.	15.4
406	4100127	25	95.5	70.0	63.5	146	337	R.F.	28.6
457	4105131	22	76.0*	58.5	55.5	140	379	R.F.	23.6
457	4105195	22	140	73.0	66.5	203	379	R.F.	26.8
457	917468	26	38.1	51.0	47.6	82.5	378	R.F.	25.0
457	917486	26	51.0*	51.0	47.6	114	378	R.F.	25.0
457	914826	26	51.0	51.0	27.3	146	400	R.F.	28.1
457	4104052	26	70.0	58.5	55.5	140	378	R.F.	29.9
457	4105140	26	76.0	58.5	55.5	140	378	R.F.	23.6
457	4100298	26	102	76.0	70.0	165	384	R.F.	36.7
457	4103348	29	102	76.0	70.0	165	384	R.F.	27.2
508	4100341	19	76.0	58.5	55.5	140	457	R.F.	30.8
508	4105239	19	95.5	70.0	54.0	165	457	R.F.	30.8
508	4100350	22	76.0	58.5	55.5	140	435	R.F.	20.4
508	4105266	22	140	73.0	66.5	203	430	R.F.	30.8
508	4100369	26	76.0	58.5	55.5	140	435	R.F.	36.4
508	4105328	26	82.5	58.5	55.5	140	435	R.F.	30.8
508	4105257	26	95.5	70.0	54.0	165	419	R.F.	30.8
508	4105275	26	140	73.0	66.5	203	435	R.F.	30.8
610	4105346	14	146	85.5	79.5	203	559	R.F.	51.3
610	4105355	22	146	85.5	79.5	203	533	R.F.	60.3
610	4100859	26	102	76.0	70.0	165	537	R.F.	36.3

McKissick® Roll-Forged™ sheaves highlighted above in bold italic are available with reduced lead times due to our advanced manufacturing process.

\*\* Without Flame Harden groove.

\*Self Lubricating Bushing.

# McKissick® Bronze Bushed Sheaves



"A" Nominal Outside Diameter (mm)	Stock Number	Wireline Size (mm)	"D" Shaft Size (mm)	Hub Width (mm)	Rim Width (mm)	"C" Nominal Hub Outside Diameter (mm)	"B" Nominal Tread Diameter (mm)	Material	Approx. Weight (kg)
<b>610</b>	<b>4105382</b>	<b>26</b>	<b>140</b>	<b>73.0</b>	<b>66.5</b>	<b>203</b>	<b>537</b>	<b>R.F.</b>	<b>59.0</b>
<b>610</b>	<b>4100868</b>	<b>28</b>	<b>102</b>	<b>76.0</b>	<b>70.0</b>	<b>165</b>	<b>510</b>	<b>R.F.</b>	<b>49.9</b>
<b>610</b>	<b>4105391</b>	<b>28</b>	<b>140</b>	<b>73.0</b>	<b>66.5</b>	<b>203</b>	<b>510</b>	<b>R.F.</b>	<b>60.8</b>
<b>610</b>	<b>4105373</b>	<b>28</b>	<b>146</b>	<b>85.5</b>	<b>79.5</b>	<b>203</b>	<b>510</b>	<b>R.F.</b>	<b>62.1</b>
<b>762</b>	<b>4105426</b>	<b>22</b>	<b>146</b>	<b>85.5</b>	<b>79.5</b>	<b>203</b>	<b>686</b>	<b>R.F.</b>	<b>92.1</b>
<b>762</b>	<b>4101215</b>	<b>22</b>	<b>152</b>	<b>89.0</b>	<b>79.5</b>	<b>203</b>	<b>686</b>	<b>R.F.</b>	<b>63.5</b>
<b>762</b>	<b>4105435</b>	<b>26</b>	<b>146</b>	<b>85.5</b>	<b>79.5</b>	<b>203</b>	<b>686</b>	<b>R.F.</b>	<b>92.1</b>
<b>762</b>	<b>4105453</b>	<b>26</b>	<b>178</b>	<b>89.0</b>	<b>79.5</b>	<b>241</b>	<b>686</b>	<b>R.F.</b>	<b>95.7</b>
<b>762</b>	<b>4105444</b>	<b>28</b>	<b>146</b>	<b>85.5</b>	<b>79.5</b>	<b>203</b>	<b>686</b>	<b>R.F.</b>	<b>92.1</b>
<b>762</b>	<b>4105462</b>	<b>28</b>	<b>178</b>	<b>89.0</b>	<b>79.5</b>	<b>241</b>	<b>670</b>	<b>R.F.</b>	<b>95.7</b>
<b>762</b>	<b>4105471</b>	<b>28</b>	<b>178</b>	<b>89.0</b>	<b>79.5</b>	<b>241</b>	<b>670</b>	<b>R.F.</b>	<b>95.7</b>

Self Lubricating Bronze Bushing.

Without Flame Hardening.

Material: B.S.B ar Steel, C.I.€ ast Iron, F.S.F orged Steel, D.I.Ð uctile Iron, C.S.€ ast Steel, P.M.Ɔ ounded Metal, R.F.R oll-Forged.

McKissick® Roll-Forged sheaves highlighted above in bold italic are available with reduced lead times due to our advanced manufacturing process.

# McKissick® Roller Bearing Sheaves

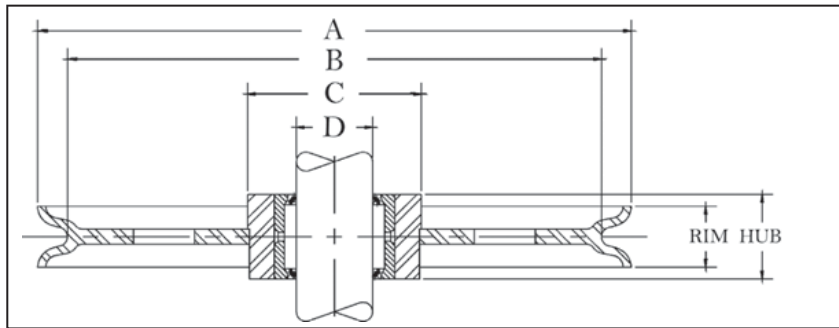

## Roller Bearing Sheaves

- Roll-Forged sheaves are available in sizes up to 1981mm diameter.
- McKissick® Roller Bearing Sheaves are designed to operate on shafts carburized to 60 Rockwell C and groove to  $\pm .0005$  of the indicated shaft size. Some sizes are available with an optional inner race. Check with Crosby Sales for prices and correct shaft size.
- Application should provide for 79mm running clearance over the hub width.
- For sizes not listed, McKissick Finished Bore Sheaves can be equipped with Roller Bearings at an optional charge.

"A" Nominal Outside Diameter (mm)	Stock Number	Wireline Size (mm)	"D" Shaft Size (mm)	Hub Width (mm)	Rim Width (mm)	"C" Nominal Hub Outside Diameter (mm)	"B" Nominal Tread Diameter (mm)	Material	Approx. Weight (kg)
102	472508	3	25.3	25.4	22.2	51.0	79.5	B.S.	.91
102	472517	6	25.3	25.4	22.2	51.0	79.5	B.S.	.91
102	472535	10	25.3	25.4	22.2	51.0	79.5	B.S.	.91
102	2025893	10	25.3	38.1	34.9	51.0	76.0	F.S.	1.59
102	2028063	13	25.3	38.1	34.9	51.0	76.0	F.S.	1.59
102	2025891	16	25.3	38.1	34.9	51.0	76.0	F.S.	1.59
124	472768	10	31.7	31.8	28.6	57.0	103	F.S.	1.63
124	472777	13	31.7	31.8	28.6	57.0	103	F.S.	1.63
124	472786	16	31.7	31.8	28.6	57.0	103	F.S.	1.63
133	2026427	16	25.3	38.1	34.9	52.5	98.5	F.S.	1.81
133	2026423	19	25.3	38.1	34.9	52.5	98.5	F.S.	1.81
149	2023141	16	38.0	44.5	41.3	63.5	111	F.S.	2.72
149	2023143	19	38.0	44.5	41.3	63.5	111	F.S.	2.72
149	2023142	22	38.0	44.5	41.3	63.5	111	F.S.	2.72

McKissick® Roll-Forged sheaves highlighted above in bold italic are available with reduced lead times due to our advanced manufacturing process.

\* Without Flame Harden groove.

MCKISSICK® SHEAVES



"A" Nominal Outside Diameter (mm)	Stock Number	Wireline Size (mm)	"D" Shaft Size (mm)	Hub Width (mm)	Rim Width (mm)	"C" Nominal Hub Outside Diameter (mm)	"B" Nominal Tread Diameter (mm)	Material	Approx. Weight (kg)
152	472875	13	50.5	44.5	31.8	79.5	121	F.S.	3.18
191	2025898	16	25.3	38.1	34.9	52.5	160	F.S.	3.40
191	2025892	19	25.3	38.1	34.9	52.5	160	F.S.	3.40
194	473311	10	25.3	38.1	31.8	50.5	157	D.I.	3.18
194	473320	13	25.3	38.1	31.8	60.5	157	D.I.	3.18
194	473339	16	25.3	38.1	31.8	60.5	157	D.I.	3.18
203	2023163	19	38.0	44.5	41.3	65.0	160	F.S.	4.54
203	2023155	13	38.0	44.5	41.3	65.0	160	F.S.	4.54
203	2023159	16	38.0	44.5	41.3	65.0	160	F.S.	4.54
203	2023404	19	50.5	58.5	54.0	82.5	156	F.S.	5.67
251	2026433	13	38.0	44.5	41.3	65.0	211	F.S.	6.58
251	2023179	16	38.0	44.5	41.3	65.0	211	F.S.	6.58
251	2023181	19	38.0	44.5	41.3	65.0	211	F.S.	6.58
251	2023436	19	50.5	58.5	55.6	89.0	206	F.S.	6.80
305	2023248	16	38.0	44.5	41.3	82.5	257	F.S.	8.16
305	2023236	19	38.0	44.5	41.3	82.5	248	F.S.	8.16
305	2026441	22	38.0	44.5	41.3	82.5	260	F.S.	8.16
<b>305</b>	<b>474365</b>	<b>16</b>	<b>57.0</b>	<b>44.5</b>	<b>41.3</b>	<b>114</b>	<b>257</b>	<b>F.S.</b>	<b>7.26</b>
<b>305</b>	<b>474374</b>	<b>19</b>	<b>57.0</b>	<b>44.5</b>	<b>41.3</b>	<b>114</b>	<b>248</b>	<b>R.F.</b>	<b>7.26</b>
<b>356</b>	<b>2026445</b>	<b>16</b>	<b>38.0</b>	<b>44.5</b>	<b>41.3</b>	<b>82.5</b>	<b>305</b>	<b>R.F.</b>	<b>9.07</b>
<b>356</b>	<b>2026444</b>	<b>22</b>	<b>38.0</b>	<b>44.5</b>	<b>41.3</b>	<b>82.5</b>	<b>298</b>	<b>R.F.</b>	<b>9.07</b>
<b>356</b>	<b>474784</b>	<b>22</b>	<b>38.0</b>	<b>44.5</b>	<b>41.3</b>	<b>82.5</b>	<b>311</b>	<b>R.F.</b>	<b>9.07</b>
<b>356</b>	<b>4200563</b>	<b>16</b>	<b>50.5</b>	<b>44.5</b>	<b>41.3</b>	<b>114</b>	<b>308</b>	<b>R.F.</b>	<b>14.1</b>
<b>356</b>	<b>4200572</b>	<b>19</b>	<b>50.5</b>	<b>44.5</b>	<b>41.3</b>	<b>114</b>	<b>298</b>	<b>R.F.</b>	<b>14.1</b>
<b>406</b>	<b>4200705</b>	<b>22</b>	<b>63.5</b>	<b>58.5</b>	<b>55.5</b>	<b>114</b>	<b>329</b>	<b>R.F.</b>	<b>21.7</b>
<b>457</b>	<b>4201438</b>	<b>22</b>	<b>70.0</b>	<b>58.5</b>	<b>55.5</b>	<b>140</b>	<b>379</b>	<b>R.F.</b>	<b>19.4</b>
<b>457</b>	<b>4200867</b>	<b>25</b>	<b>70.0</b>	<b>58.5</b>	<b>55.5</b>	<b>140</b>	<b>378</b>	<b>R.F.</b>	<b>29.9</b>
<b>508</b>	<b>4200929</b>	<b>25</b>	<b>76.0</b>	<b>58.5</b>	<b>55.5</b>	<b>140</b>	<b>419</b>	<b>R.F.</b>	<b>34.9</b>
<b>610</b>	<b>4200117</b>	<b>25</b>	<b>57.0</b>	<b>63.5</b>	<b>60.5</b>	<b>140</b>	<b>537</b>	<b>R.F.</b>	<b>34.0</b>

\* Without Flame Hardening

Material: B.S.B ar Steel, C.I.€ ast Iron, F.S.F orged Steel, D.I.€ uctile Iron, C.S.€ ast Steel, P.M.® owdered Metal, R.F.R oll-Forged.

McKissick® Roll-Forged sheaves highlighted above in bold italic are available with reduced lead times due to our advanced manufacturing process.

# McKissick® Tapered Bearing Sheaves

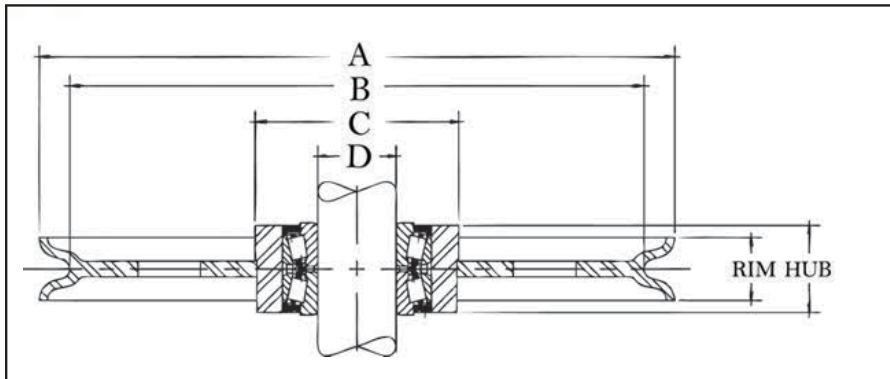

## Tapered Bearing Sheaves

- Roll-Forged sheaves are available in sizes up to 1981mm diameter.
- Tapered Bearing Sheaves are designed to operate on shafts machined to +/- .0005 of the indicated shaft size.
- Applications should provide for tightening separator plates against bearing cones to adjust and insure proper function of bearing.
- For sizes not listed, McKissick® Finished Bore Sheaves can be equipped with tapered bearing at an optional charge.

"A" Nominal Outside Diameter (mm)	Stock Number	Wireline Size (mm)	"D" Shaft Size (mm)	Hub Width (mm)	Rim Width (mm)	"C" Nominal Hub Outside Diameter (mm)	"B" Nominal Tread Diameter (mm)	Material	Approx. Weight (kg)
124	480269	10	19.0	34.9	28.6	57.0	103	F.S.	1.63
178	480777	6	19.0	34.9	19.1	60.5	159	B.S.	4.08
203	481017	13	19.0	34.9	31.8	62.0	168	F.S.	3.18
216	481044	10	19.0	34.9	25.4	70.0	191	D.I.	3.40
248	481295	10	38.1	58.5	25.4	95.5	222	F.S.	5.08
302	481552	6	38.1	58.5	25.4	95.5	273	D.I.	5.44
<b>305</b>	<b>481455</b>	<b>19</b>	<b>38.1</b>	<b>58.5</b>	<b>55.5</b>	<b>114</b>	<b>248</b>	<b>R.F.</b>	<b>10.9</b>
<b>305</b>	<b>481446</b>	<b>22</b>	<b>38.1</b>	<b>58.5</b>	<b>55.5</b>	<b>114</b>	<b>260</b>	<b>R.F.</b>	<b>10.9</b>
<b>406</b>	<b>4302793</b>	<b>13</b>	<b>51.0</b>	<b>74.5</b>	<b>63.5</b>	<b>146</b>	<b>362</b>	<b>R.F.</b>	<b>22.7</b>
<b>406</b>	<b>4300599</b>	<b>19</b>	<b>51.0</b>	<b>74.5</b>	<b>63.5</b>	<b>146</b>	<b>340</b>	<b>R.F.</b>	<b>24.9</b>
<b>406</b>	<b>4300018</b>	<b>22</b>	<b>38.1</b>	<b>58.5</b>	<b>55.5</b>	<b>114</b>	<b>329</b>	<b>R.F.</b>	<b>16.8</b>
<b>406</b>	<b>4300054</b>	<b>26</b>	<b>51.0</b>	<b>74.5</b>	<b>63.5</b>	<b>146</b>	<b>340</b>	<b>R.F.</b>	<b>19.1</b>
<b>457</b>	<b>4300081</b>	<b>19</b>	<b>51.0</b>	<b>74.5</b>	<b>55.5</b>	<b>165</b>	<b>406</b>	<b>R.F.</b>	<b>18.1</b>
<b>508</b>	<b>*4302524</b>	<b>8</b>	<b>51.0</b>	<b>74.5</b>	<b>34.9</b>	<b>146</b>	<b>479</b>	<b>R.F.</b>	<b>24.5</b>
<b>508</b>	<b>4300161</b>	<b>19</b>	<b>51.0</b>	<b>74.5</b>	<b>54.0</b>	<b>165</b>	<b>457</b>	<b>R.F.</b>	<b>39.5</b>
<b>508</b>	<b>4300189</b>	<b>26</b>	<b>51.0</b>	<b>74.5</b>	<b>54.0</b>	<b>165</b>	<b>419</b>	<b>R.F.</b>	<b>38.1</b>
<b>610</b>	<b>4301721</b>	<b>14</b>	<b>108</b>	<b>89.0</b>	<b>79.5</b>	<b>203</b>	<b>559</b>	<b>R.F.</b>	<b>57.0</b>
<b>610</b>	<b>*4302720</b>	<b>16</b>	<b>70.0</b>	<b>74.5</b>	<b>38.1</b>	<b>165</b>	<b>552</b>	<b>R.F.</b>	<b>62.0</b>
<b>610</b>	<b>4300312</b>	<b>22</b>	<b>108</b>	<b>89.0</b>	<b>79.5</b>	<b>203</b>	<b>530</b>	<b>R.F.</b>	<b>57.0</b>
<b>610</b>	<b>4300321</b>	<b>26</b>	<b>108</b>	<b>89.0</b>	<b>79.5</b>	<b>194</b>	<b>537</b>	<b>R.F.</b>	<b>57.0</b>
<b>610</b>	<b>4300401</b>	<b>28</b>	<b>70.0</b>	<b>74.5</b>	<b>70.0</b>	<b>165</b>	<b>510</b>	<b>R.F.</b>	<b>36.0</b>
<b>610</b>	<b>4300330</b>	<b>28</b>	<b>108</b>	<b>89.0</b>	<b>79.5</b>	<b>203</b>	<b>510</b>	<b>R.F.</b>	<b>57.0</b>
<b>610</b>	<b>4300269</b>	<b>38</b>	<b>108</b>	<b>89.0</b>	<b>79.5</b>	<b>210</b>	<b>508</b>	<b>R.F.</b>	<b>57.0</b>
<b>762</b>	<b>4300483</b>	<b>22</b>	<b>108</b>	<b>89.0</b>	<b>79.5</b>	<b>203</b>	<b>686</b>	<b>R.F.</b>	<b>64.0</b>
<b>762</b>	<b>4300492</b>	<b>26</b>	<b>108</b>	<b>89.0</b>	<b>79.5</b>	<b>194</b>	<b>686</b>	<b>R.F.</b>	<b>95.0</b>
<b>762</b>	<b>4300526</b>	<b>26</b>	<b>143</b>	<b>93.5</b>	<b>79.5</b>	<b>241</b>	<b>686</b>	<b>R.F.</b>	<b>86.0</b>
<b>762</b>	<b>4300508</b>	<b>28</b>	<b>108</b>	<b>89.0</b>	<b>79.5</b>	<b>203</b>	<b>686</b>	<b>R.F.</b>	<b>64.0</b>
<b>762</b>	<b>4300535</b>	<b>28</b>	<b>143</b>	<b>93.5</b>	<b>79.5</b>	<b>241</b>	<b>670</b>	<b>R.F.</b>	<b>64.0</b>
<b>762</b>	<b>4300704</b>	<b>32</b>	<b>143</b>	<b>93.5</b>	<b>79.5</b>	<b>241</b>	<b>670</b>	<b>R.F.</b>	<b>64.0</b>

\* Without Flame Harden groove.

Material: B.S. B ar Steel, C.I. E ast Iron, F.S. F orged Steel, D.I. D uctile Iron, C.S. E ast Steel, P.M. P owdered Metal, R.F. R ollForged.

McKissick® Roll-Forged sheaves highlighted above in bold italic are available with reduced lead times due to our advanced manufacturing process.

Custom sheaves are available. See page 287 for ordering details.

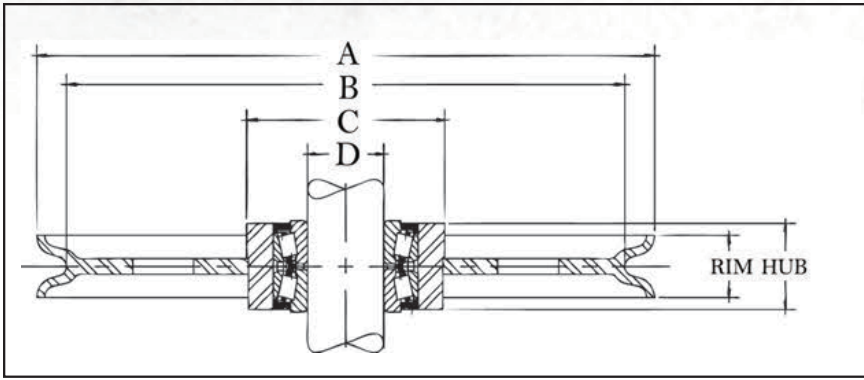

## Plain Bore Oilfield Sheaves

McKissick® Roll-Forged Sheaves are available in many configurations in order to meet various oilfield applications.

- Roll-Forged sheaves are available in sizes up to 1981mm diameter.
- Applications should provide for tightening separator plates against bearing cones to adjust and insure proper function of bearing.
- Each sheave in the table below has a machined bore sized to accept the respective bearing number shown.
- The sheaves are provided from the factory plain bore (the bearings are not included)

"A" Nominal Outside Diameter (mm)	Stock Number	Wireline Size (mm)	Bore Information			Hub Width (mm)	Rim Width (mm)	"C" Nominal Hub Outside Diameter (mm)	"B" Nominal Tread Diameter (mm)	Material	Approx. Weight (kg)
			"D" Bore Size (mm)	Bearing Info. (Bearing not included)							
				Shaft Size (mm)	Bearing or Equivalent Description						
<b>508mm Sheave</b>											
508	2030311	14	120	70	NA-483-SW-472-D	70.0	70.0	165	448	R.F.	36.3
508	2029285	16	120	70	NA-483-SW-472-D	70.0	70.0	165	452	R.F.	34.0
<b>610mm Sheave</b>											
610	2030941	14	165	108	NA56425-SW-56650D	35.7	79.4	203	549	R.F.	46.7
610	2030905	16	165	108	NA56425-SW-56650D	35.7	76.2	203	559	R.F.	53.1
610	2026108	22	165	108	NA56425-SW-56650D	35.7	79.4	203	532	R.F.	58.1
610	2025931	26	165	108	NA56425-SW-56650D	35.7	79.4	229	536	R.F.	57.7
<b>610mm Crown Sheave**</b>											
610	2027885	14	165	108	NA56425-SW-56650D	85.7	79.4	203	549	R.F.	40.8
610	2027887	16	165	108	NA56425-SW-56650D	85.7	69.9	203	559	R.F.	36.3
610	2027880	22	165	108	NA56425-SW-56650D	85.7	79.4	203	532	R.F.	56.7
610	2023993	26	165	108	NA56425-SW-56650D	85.7	79.4	229	536	R.F.	49.9
<b>762mm Sheave</b>											
762	2026299	26	165	108	NA56425-SW-56650D	85.7	79.4	216	673	R.F.	86.2
762	2026036	28	165	108	NA56425-SW-56650D	85.7	79.4	229	662	R.F.	104
762	2026230	26	200	143	NA48685-SW/48620	88.9	79.4	260	573	R.F.	116
762	2026003	28	200	143	NA48685-SW/48620	88.9	79.4	260	662	R.F.	116
762	2030906	26	225	165	NA46790-SW-46720	92.1	85.7	260	673	R.F.	83.9
762	2030907	28	225	165	NA46790-SW-46720	92.1	85.7	305	662	R.F.	120
<b>762mm Crown Sheave**</b>											
762	2027941	26	165	108	NA56425-SW-56650D	85.7	79.4	229	673	R.F.	68.0
762	2027945	28	165	108	NA56425-SW-56650D	85.7	79.4	229	662	R.F.	90.7
762	2030274	26	200	143	NA48685-SW/48620	88.9	79.4	260	673	R.F.	73.0
762	2030260	28	200	143	NA48685-SW/48620	88.9	79.4	260	662	R.F.	98.9
<b>917mm Sheave</b>											
917	2030942	26	200	143	NA48685-SW/48620	88.9	82.6	260	841	R.F.	159
917	2030908	28	200	143	NA48685-SW/48620	88.9	82.6	260	854	R.F.	159
917	2027967	32	200	143	NA48685-SW/48620	88.9	82.6	305	819	R.F.	145
917	2030943	26	225	165	NA46790-SW-46720	92.1	79.4	292	841	R.F.	160
917	2029390	28	225	165	NA46790-SW-46720	92.1	82.6	279	854	R.F.	136
917	2029392	32	225	165	NA46790-SW-46720	92.1	82.6	279	819	R.F.	136
917	2030944	26	276	203	LM241149NW/241110-D	92.1	79.4	356	841	R.F.	168
917	2030909	28	276	203	LM241149NW/241110-D	92.1	88.9	356	814	R.F.	162
917	2030945	32	276	203	LM241149NW/241110-D	92.1	85.7	356	819	R.F.	150
<b>917mm Crown Sheave**</b>											
917	2030282	26	200	143	NA48685-SW/48620	88.9	82.6	260	841	R.F.	109
917	2030284	28	200	143	NA48685-SW/48620	88.9	82.6	260	829	R.F.	113

\*\* Crown Sheaves contain lightning holes.

Custom sheaves are available. See page 287 for ordering details.



# McKissick® Standard API 8c Oilfield Sheaves



"A" Nominal Outside Diameter (mm)	Stock Number	Wireline Size (mm)	Bore Information			Hub Width (mm)	Rim Width (mm)	"C" Nominal Hub Outside Diameter (mm)	"B" Nominal Tread Diameter (mm)	Material	Approx. Weight (kg)
			"D" Bore Size (mm)	Bearing Info. (Bearing not Included)							
				Shaft Size (mm)	Bearing or Equivalent Description						
<b>1067mm Sheave</b>											
1067	2030946	28	225	165	NA46790-SW-46720	92.1	82.6	305	981	R.F.	209
1067	2030947	32	225	165	NA46790-SW-46720	92.1	82.6	292	972	R.F.	213
1067	2030948	28	276	203	LM241149NW/241110-D	92.1	82.6	356	981	R.F.	211
1067	2030949	22	276	203	LM241149NW/241110-D	92.1	82.6	356	972	R.F.	209
1067	2030950	28	327	235	NA8575SW-8520CD	114	88.9	406	981	R.F.	211
1067	2030951	32	327	235	NA8575SW-8520CD	114	85.7	406	972	R.F.	215
<b>1118mm Sheave</b>											
1118	2030952	28	276	203	LM241149NW/241110-D	92.1	85.7	356	1018	R.F.	279
1118	2030953	32	276	203	LM241149NW/241110-D	92.1	76.2	356	1022	R.F.	247
<b>1270mm Sheave</b>											
1219	2030954	28	276	203	LM241149NW/241110-D	92.1	82.6	356	1133	R.F.	263
1219	2030955	32	276	203	LM241149NW/241110-D	92.1	69.9	356	1124	R.F.	232
1219	2030956	32	348	251	LM249747NWL/249710D	98.4	82.6	432	1124	R.F.	290
<b>1270mm Sheave</b>											
1270	2030938	28	276	203	LM241149NW/241110-D	92.1	85.7	356	1175	R.F.	347
1270	2030957	28	276	251	LM241149NW/241110-D	98.4	82.6	432	1175	R.F.	347
1270	2030958	35	348	251	LM249747NWL/249710D	98.4	95.3	432	1159	R.F.	333
<b>1397mm Sheave</b>											
1397	2030959	28	327	235	NA8575SW-8520CD	114	88.9	406	1297	R.F.	404
1397	2030960	32	327	235	NA8575SW-8520CD	114	85.7	406	1302	R.F.	374
1397	2030961	32	348	251	LM249747NWL/249710D	98.4	88.9	483	1302	R.F.	267
<b>1524mm Sheave</b>											
1524	2030879	32	348	251	LM249747NWL/249710D	98.4	82.6	432	1429	R.F.	497
1524	2030880	35	352	267	LM251649NW/251610-D	105	92.1	483	1419	R.F.	533
1524	2030881	35	394	305	L357049NW/L357010D	105	95.3	483	1419	R.F.	533
1524	2030875	38	348	251	LM249747NWL/249710D	98.4	88.9	483	1410	R.F.	533
1524	2030872	38	352	267	LM251649NW/251610-D	105	92.1	483	1410	R.F.	533
1524	2030876	38	394	305	L357049NW/L357010D	105	88.9	483	1410	R.F.	528
1524	2030877	38	394	305	L357049NW/L357010D	105	88.9	483	1400	R.F.	1150

Custom sheaves are available. See page 287 for ordering details.

**McKissick® manufactures special Roll-Forged Sheaves to meet the Specifications of AISE Standard Number 6.**

- AISE Sheaves must meet specified criteria established by the Association of Iron and Steel Engineers for special use in electric overhead Traveling Cranes for Steel Mill Service.
- Other typical applications that may specify AISE sheaves:
  - Mobile Cranes
  - Portal Cranes
  - Power Shovels
  - Other equipment using Wireline

**Typical AISE Sheave Rim Profile with Specified Dimensional Requirements**

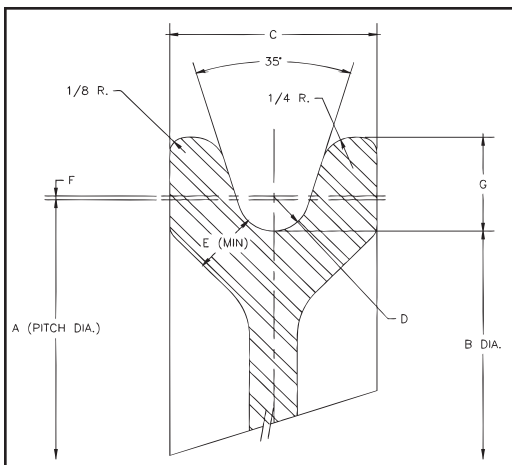

Sheave Wheel Contours							
Rope Diameter* (mm)	Dimensions (mm)						
	A	B	C	D	E	F	G
13	381	368	44.5	7.1	12.7	.8	19.1
16	476	461	51.0	8.7	16.0	.8	23.8
19	572	552	57.0	10.3	19.1	.8	28.6
22	667	645	63.5	12.3	22.2	1.2	33.4
25	762	737	70.0	13.9	25.4	1.2	38.1
28	857	829	76.0	15.4	28.6	1.2	42.9
32	953	921	82.5	17.5	31.8	1.6	47.6
35	1048	1013	89.0	19.1	34.9	1.6	52.5
38	1143	1105	95.5	20.6	38.1	1.6	57.0

\* Sheaves with other Wireline sizes are available upon request. Other pitch diameters available on application basis. Grooves are flame hardened to min. RC35 for 12.7mm Wireline and larger.

**For additional information concerning special AISE sheaves, contact:**

**In U.S.A.** - Crosby's Special Engineered Product Group at 1-800-777-1555

**In Canada** - Crosby Canada at (905) 451-9261

**In Europe** - N.V. Crosby Europe at (3 2) (0)15 75 71 25

# McKissick® European Style 45° Metric Sheaves



## Selecting your Sheave O.D. / Wireline Size Combinations

To ease the effort in choosing the proper standard McKissick® Roll-Forged sheave required for your application, we have simplified our product offering. The table below indicates the standard Sheave O.D. / Wireline sizes that are available.

## How to Read the Table

- Cells outlined in RED represent the standard O.D. / Wireline combinations available with the Sheave Configurator program.

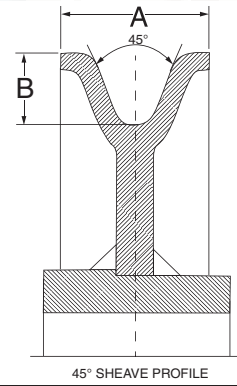

## Sheave O.D. / Wireline Information

Wireline Size (mm)	Nominal Dimensions (mm)		Groove Radius (mm)		Sheave O.D. (mm)														
	A	B	MIN	MAX	280	300	320	350	400	450	500	520	550	600	630	650	700	800	
11	40	19	5.83	6.05															
12	40	18	6.36	6.60															
13	40	18	6.89	7.15															
11	40	19.5	5.38	6.05															
12	40	20.5	6.36	6.60															
13	40	19.5	6.89	7.15															
14	40	21	7.42	7.70															
15	40	21	7.95	8.25															
16	45	25	8.48	8.80															
17	45	25	9.01	9.35															
13	40	23	6.89	7.15															
14	40	22	7.42	7.70															
15	40	22	7.95	8.25															
15	45	25	7.95	8.25															
16	45	24	8.48	8.80															
17	45	24	9.01	9.35															
15	45	26	7.95	8.25															
16	45	25	8.48	8.80															
17	50	28	9.01	9.35															
18	50	27	9.54	9.90															
19	55	28.5	10.07	10.45															
20	55	25.5	10.60	11.00															
21	60	34	11.13	11.55															
22	60	33	11.66	12.10															
23	60	33	12.19	12.65															
19	55	31	10.07	10.45															
20	55	30	10.60	11.00															
21	55	30	11.13	11.55															
21	60	34	11.13	11.55															
22	60	33	11.66	12.10															
23	60	33	12.19	12.65															
21	60	34	11.13	11.55															
22	60	33	11.66	12.10															
23	60	33	12.19	12.65															
23	65	37	12.19	12.65															
24	65	36	12.72	13.20															
25	65	36	13.25	13.75															
26	70	39	13.78	14.30															
27	70	39	14.31	14.85															
23	65	37	12.19	12.65															
24	65	36	12.72	13.20															
25	65	36	13.25	13.75															
26	70	39	13.78	14.30															
27	75	43	14.31	14.85															
28	75	42	14.84	15.40															
29	75	42	15.37	15.95															
27	75	43	14.31	14.85															
28	75	43	14.84	15.40															
29	75	42	15.37	15.95															
28	80	47	14.84	15.40															
29	80	46	15.37	15.95															
30	80	45	15.90	16.50															
32	80	45	16.96	17.60															
30	90	50	15.90	16.50															
32	90	48	16.96	17.60															
34	90	48	18.02	18.70															
34	100	56	18.02	18.70															
36	100	54	19.08	19.80															
38	100	54	20.14	20.90															

McKISSICK® SHEAVES



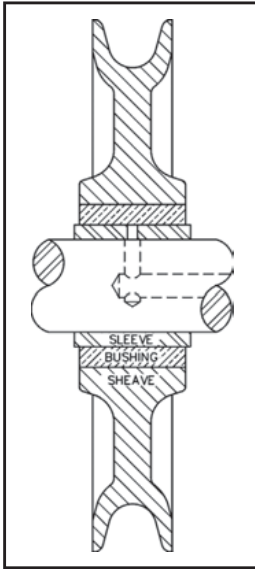

**IRON SHEAVES FOR USE WITH MANILA ROPE BLOCKS**

- 1101 – 1141  
Common Iron Bushed
- 1102 – 1142  
Roller Bushed
- 1103 – 1143  
Bronze Bushed, Self-Lubricating

**FOR REGULAR MANILA ROPE BLOCKS – OLD STYLE**

Block Size	Stock No.			Manila Rope Size (mm)	Sheave Size (mm)			Weight Each (kg)
	1101 Galv.	1102 Galv.	1103 Galv.		Outside Dia. (A)	Rim Width (B)	Bore Size (C)	
76.2	900010	900216	900412	10	44.5	12.7	9.55	.11
102	900038	900234	900430	13	57.0	15.9	9.55	.34
127	900056	900252	900458	16	76.0	19.1	9.55	.23
152	900074	900270	900476	19	89.0	25.4	12.7	.45
178	900092	900298	900494	22	108	25.4	12.7	.57
203	900118	900314	900519	25	121	28.6	15.9	.79

**FOR REGULAR MANILA ROPE BLOCKS – NEW STYLE**

Block Size	Stock No.		Manila Rope Size (mm)	Sheave Size (mm)			Sleeve Diameter (mm)		Weight Each (kg)
	Bronze Bushed			Outside Dia.	Rim Width	Bearing Diam. (C)	I.D. (F)	O.D. (E)	
102	2028373		13	57.0	15.9	15.9	9.52	15.9	.34
152	2028375		19	88.9	25.4	19.1	12.7	19.1	.45
203	2028376		25	121	28.6	22.2	15.9	22.2	.79

**FOR MANILA ROPE SNATCH BLOCKS – OLD STYLE**

Block Size	Stock No.			Manila Rope Size (mm)	Sheave Size (mm)			Sleeve Diameter (mm)		Weight Each (kg)
	1104 Galv.	1142 Galv.	1143 Galv.		Outside Dia.	Rim Width	Bearing Diam. (C)	I.D. (F)	O.D. (E)	
152	902018	902214	902410	19	76.0	28.6	19.1	12.7	19.1	.45
178	902036	902232	902438	22	89.0	31.8	19.1	12.7	19.1	.91
203	902054	902250	902456	25	114	34.9	22.2	15.9	22.2	1.36
254	902072	902278	902474	32	146	47.6	25.4	19.1	25.4	3.18
304	902090	902296	902492	38	171	54.0	25.4	19.1	25.4	5.44

**FOR MANILA ROPE SNATCH BLOCKS – NEW STYLE**

Block Size	Stock No.			Manila Rope Size (mm)	Sheave Size (mm)			Sleeve Diameter (mm)		Weight Each (kg)
	Bronze Bushed Red	Bronze Bushed Galv.			Outside Dia.	Rim Width	Bearing Diam. (C)	I.D. (F)	O.D. (E)	
152	2027020	2027021	19	76.2	22.2	19.1	-	-	.59	
203	2028971	2027015	25	105	34.9	25.4	-	-	1.70	
254	2028972	2026507	28	152	41.3	38.1	-	-	4.54	
305	2028973	2026509	32	203	41.3	38.1	-	-	5.44	

**FOR MANILA AND Wireline SNATCH BLOCKS – OLD STYLE**

- 1298 - Bronzed Brushed, Self-Lubricating Steel sheave for Wireline.
- 1192 - Bronzed Brushed, Self-Lubricating Iron sheave for Wireline.
- 1293 - Bronzed Brushed, Self-Lubricating Steel sheave for Manila Rope.

Snatch Block		Stock No.			1192 Wireline Size	1293 Painted Stock No.	1293 Manila Rope Size	Sheave Size (mm)				Bushing I.D.	Sleeve Dimensions (mm)			Weight Each (kg)		
Style	Shell Length	1298 Painted	1192 Painted	Outside Dia.				Hub Width	Rim Width	Bore Size	I.D.		O.D.	Length	1298	1192	1293	
924	-	922005	-	16	-	-	152	34.9	31.8	41.3	31.8	25.4	31.8	38.1	2.72	-	-	
924	-	922023	-	19	-	-	203	41.3	38.1	47.6	38.1	31.8	38.1	44.5	4.99	-	-	
924	-	922041	-	22	-	-	254	41.3	38.1	63.5	50.8	38.1	50.8	44.5	8.62	-	-	
<b>924</b>	-	<b>922069</b>	-	<b>22</b>	-	-	<b>305</b>	<b>50.8</b>	<b>44.5</b>	<b>63.5</b>	<b>50.8</b>	<b>38.1</b>	<b>50.8</b>	<b>54.0</b>	<b>9.98</b>	-	-	
940-941	-	922078	920579	10	-	-	102	20.6	19.1	28.6	19.1	12.7	19.1	22.2	1.36	.90	-	
940-941	-	922087	920588	13	-	-	152	27.0	25.4	34.9	25.4	19.1	25.4	28.6	3.18	2.25	-	
940-941	-	922103	920604	16	-	-	203	34.9	31.8	38.1	28.6	22.2	28.6	38.1	3.63	4.50	-	
940-941	-	922121	920622	16	-	-	254	34.9	31.8	41.3	31.8	25.4	31.8	38.1	5.44	7.70	-	
940-941	-	922149	920640	19	-	-	305	41.3	38.1	47.6	38.1	31.8	38.1	44.5	17.7	14.5	-	
1096	152	-	-	-	921505	22.2	76.0	41.3	28.6	41.3	25.4	15.9	32.1	38.1	-	-	.90	
1096	203	-	-	-	921523	25.4	114	41.3	41.3	41.3	32.0	22.2	32.1	38.1	-	-	2.70	
961	-	922407	-	16	-	-	152	41.3	38.1	50.8	41.3	31.8	41.3	41.3	4.08	-	-	
961	-	922425	-	22	-	-	203	42.9	38.1	63.5	50.8	-	-	-	6.80	-	-	

McKissick® Roll-Forged™ sheaves highlighted above in bold italic are available with reduced lead times due to our advanced manufacturing process.



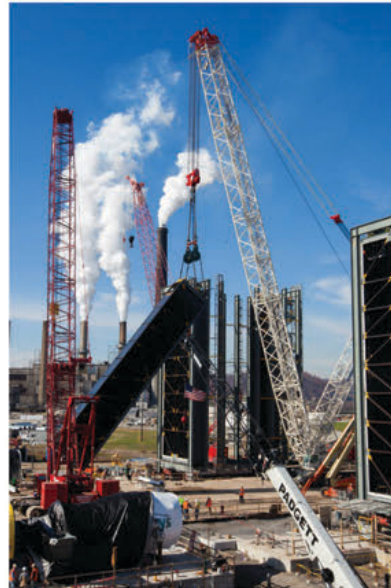

# McKISSICK BLOCKS

With Product Warnings and Application Information





418

**McKISSICK  
LEBUS**

# "There is No Equal"

The Market Leader: Yesterday Today and Tomorrow



L-170

## Snatch Blocks

### DESIGN

The theoretical reserve capability of a snatch block should be at least 4 to 1. Known as the DESIGN FACTOR, it is usually computed by dividing the ultimate load by the working load limit. The ultimate load is the average load or force at which the block fails or no longer supports the load. The working load limit is the maximum mass or force which the product is authorized to support in general service. The design factor is generally expressed as a ratio such as 4 to 1. Also important in the design of snatch blocks is the selection of proper steel used in components and consideration as to fatigue life.

**ASK:** Are their snatch blocks metric rated?

**ASK:** What is the metric design factor?

**ASK:** Are their snatch blocks fatigue rated?

Most do not provide metric ratings with a design factor of 4 to 1, nor fatigue rated snatch blocks.

## Crosby®

McKissick and Lebus snatch blocks are dual rated with a design factor of 4 to 1 for metric and 4.5 to 1 in short tons. McKissick and Lebus snatch blocks incorporate the proper selection of steel and are also fatigue rated.

**Fatigue Rated**

### END FITTING CONNECTIONS

Interchangeability of end fittings is important, and should be easily achieved without disassembly of the block. It is also important that end fittings are quenched and tempered in order to reduce the risk of brittle, catastrophic failure.

### THE COMPETITION

**ASK:** Are the end fittings forged, quenched and tempered?

**ASK:** Are the end fittings inter-changeable?

## Crosby®

McKissick and Lebus snatch blocks use genuine Crosby forged, quenched and tempered hooks and shackles..



### BLOCK CONSTRUCTION

The block performance depends greatly on the sheave and block construction. All steel construction, including side plates, pins, and sheaves, is desirable. Bronze bushings are recommended for slow line speeds and frequent use. Roller bearings are recommended for faster line speeds and more frequent use at greater loads. The ability to individually lubricate all sheaves is essential. Secondary securement of bolt connecting the end fitting to the block is recommended.

### ASK THE COMPETITION

**ASK:** Are their blocks all steel construction?

**ASK:** Do their blocks have secondary securement of the pins?

**ASK:** Are all sheaves individually lubricated?

## Crosby®

McKissick and Lebus snatch blocks are of all steel construction. They also have a secondary end fitting securement system. In addition, sheaves are individually lubricated.

### FULL LINE IDENTIFICATION

The availability of a full range of snatch blocks is essential to insure that the appropriate block is available for a specific application. All snatch blocks must be identified by type, size of block, size of Wireline to be used, working load limit, and the manufacturer's name boldly marked on the product.

### THE COMPETITION

**ASK:** Do they have a full range of snatch blocks?

**ASK:** Are their snatch blocks properly marked with critical information?

Most competitors do not have the full range of snatch blocks that Crosby offers.

## Crosby®

McKissick and Lebus provide the most complete line of snatch blocks in the industry. All McKissick and Lebus snatch blocks are identified by type, size of block, size of Wireline to be used, working load limit (in both metric and short tons), and the manufacturer's name boldly marked on the product.

### STANDARDS ORGANIZATION

All snatch blocks utilized in the oilfield should be manufactured by a source that is both API Q1 and ISO 9001 certified.

### THE COMPETITION

**ASK:** Are they API Q1 certified?

**ASK:** Are they ISO 9001 certified?

Most competitors are not API Q1 certified or ISO 9001 certified.

## Crosby®

Crosby's McKissick plant is API Q1 certified. McKissick is also certified to ISO 9001 standards by Det Norske Veritas (DNV).

### APPLICATION INFORMATION

Detailed application information will assist you in the proper selection of snatch blocks. This information is most effective when provided at the point of application, as well as in supporting brochures and engineering information. A formal application and warning system that attracts the attention of the user, clearly informs the user of the factors involved in the task, and informs the user with the proper application procedures is needed.

### THE COMPETITION

**ASK:** Does each snatch block have the application and warning information attached to it?

Most competitors do not have application and warning information with each snatch block.

## Crosby®

Crosby provides detailed application and warning information attached to each snatch block.

**Remember: "When buying Crosby, you're buying more than product, you're buying Quality."**



- **Dual Rated:** To meet the requirements of both short tons and metric tons.
- **Metric Rating:** McKissick® and Lebus® snatch blocks are metric rated to a design factor of 4 to 1. Since they are metric rated, with a world class design, they are applicable to worldwide use without conversion.
- **U.S. Rating:** When compared to other blocks which are rated in short tons, the design factor of McKissick® and Lebus® snatch blocks is 4.5 to 1.
- **Fatigue Properties:** McKissick® and Lebus® snatch blocks are fatigue rated. The blocks are designed to meet specific fatigue performance levels. They meet the requirements for the new Euronorm Standards: 20,000 cycles at 1-1/2 times the Working Load Limit.
- **Latch Kits:** McKissick® and Lebus® snatch blocks, utilizing a hook as an end fitting connection, can be equipped with latches.
- **Application Information:** Application and warning information for tackle block systems is attached directly to each block. In addition, each block has a product warning sticker attached directly to it for the purpose of giving specific warning instructions about the block.
- **Lock Nut:** McKissick® snatch blocks have a special high performance lock nut on the nonmoveable side plate for securing the sheave pin.
- **Sheave and Wireline:** Sheaves for McKissick® and Lebus® snatch blocks have a machine formed groove.
- **Secondary Securement Systems:** McKissick® and Lebus® snatch blocks are designed to incorporate a secondary securement system which retains the end fitting connection bolt when the block is in the closed position. In addition, a patented system retains the end fitting connection bolt when the block is in the open position, thus eliminating the loss of block parts.
- **RFID Equipped:** All snatch blocks with sheave diameters of 4-1/2" and larger are equipped with RFID chips to provide a streamlined and automated approach to the inspection process.

**404****TAILBOARD****418****WITH HOOK****419****WITH SHACKLE**

## BLOCKS

### THE FOLLOWING INFORMATION SHOULD BE SPECIFIED:

1. Stock number (if known)
2. Sheave Size
3. Block Number (Catalog number)
4. Number of Sheaves
5. Type of Bearings: (BB) Bronze Bushed, (RB) Roller, (TB) Tapered Roller
6. Type of Hook or Shackle
7. Wireline Diameter

All crane and some construction blocks are available as shown or with swivel shackle assembly, duplex swivel hook assembly or quadruple hook assembly (as illustrated on page 309). Various combinations of bearing assemblies can be furnished; such as bronze bushed sheaves and swivel hooks, roller or tapered roller bearing sheaves and hook assemblies or a combination of bronze, roller or tapered roller bearings.

### EXAMPLE:

18" 380 Series, Triple Sheave, Roller Bearing Crane Block with Roller Bearing Swivel Hook, 60 ton, light weight, 1" Wireline diameter.  
Model Number M60T18L, Stock Number 2012187

## SHEAVES

### THE FOLLOWING INFORMATION SHOULD BE SPECIFIED:

1. Stock number (if known)
2. Sheave O.D.
3. Bearing Type or Plain Bore
4. Shaft or Bore Size
5. Hub Width
6. Rim Width
7. Wireline Size
8. Special Machine Features
9. Special Finishes

If hub or rim dimensions necessitate a dimension other than those shown in this catalog, please contact Crosby for minimums and maximums. Tapered roller bearing sheaves show width over bearing cones, which cannot be altered.

Price and delivery for your special needs, if not shown, are available upon request.

### U.S.A.

The Crosby Group  
P.O. Box 3128  
Tulsa, Ok. 74101-3128  
(918) 834-4611  
Fax (918) 832-0940  
www.thecrosbygroup.com  
crosbygroup@thecrosbygroup.com

### CANADA

1195 Courtney Park Drive East  
Mississauga, Ontario,  
Canada L5T 1R1  
(905) 670-0009  
Fax (905) 670-7856  
www.thecrosbygroup.com  
sales@crosby.ca

### EUROPE

Industriepark Zone B n°26,  
2220 Heist-op-den-Berg  
Belgium  
(+32) (0)15 75 71 25  
Fax (+32) (0)15 75 37 64  
www.thecrosbygroup.com  
sales@crosbyeurope.com





SOME OF THE MOST IMPORTANT CONSIDERATIONS IN YOUR BLOCK REQUIREMENTS ARE:

## Available Bearing Types



Bronze Bushed - S.A.E. 660 bronze with figure "8" oil groove



Double Row Sealed Tapered Roller Bearing



Straight Roller Bearing



Full Complement Cylindrical Roller Bearing



Unretouched photograph of a section cut from a flame hardened McKissick sheave (etched 2-1/2 Minutes).

## THE SHEAVE

Note the groove form with proper line support and gently rounded lips to prevent line chafing when fleet angles etc. are present.

Note the groove is completely machined to proper line size.

Note the dense martensitic structure clearly outlined by the etch. This flame hardened surface in the wear area of the sheave always presents a smooth, uncorrugated, proper size groove face to the line. Sheaves (356mm) 14" diameter and over are flame hardened in groove to minimum 35 Rockwell C. Smaller sheaves can be flame hardened on special order.

## ADDITIONAL CONNECTIONS

All Crane and Construction Blocks can be Furnished with:



Swivel shackle, in selected capacities, with bronze thrust or roller thrust bearing.



Single hook in capacities to 300 tonnes (See page 453).



Duplex swivel hook in standard capacities to 1,000 tonnes. Larger sizes available (See page 455).



Quad swivel hook from 200 tonnes and larger.



## 380 SERIES HOOK BLOCKS

- Wide range of product available.
  - Capacity: 4,5 to 270 t - Larger Models Available.
  - Sheave Sizes: 254 to 762mm.
  - Wireline Sizes: 11 to 35mm.
- Manufactured by an ISO 9001 and API Q1 certified facility.
- All single point shank hooks are genuine Crosby®, forged alloy steel, Quenched and Tempered, and have the patented **QUIC-CHECK®** markings (Duplex hooks are available on all sizes).
- All 380 Blocks are furnished standard with Roller Bearings.
- Reeving Guide Standard – All Models.
- Blocks thru 23 tons use 319N style hooks with S-4320 latches.
- Sheaves lubrication through center pin – separate lube channel to each bearing.
- Sheave fully protected by side plates.
- Dual action hook (swings and rotates).
- Repair parts available through worldwide distribution network.
- Design Factor of 4 to 1 (unless otherwise noted).
- All 380 blocks 406mm and larger are furnished with McKissick® Roll-Forged sheaves with flame hardened grooves.
- “Look for the Orange Hook . . . the mark of genuine McKissick® quality”.



### OPTIONS AVAILABLE

- Bronze Bushed Sheaves
- Duplex Hooks
- Swivel Tee and Shackle Assemblies
- Sheave Shrouds
- Anti Rotation Hook - Locking Device
- Plate Steel Cheek Weights
- Third party testing with Certification available upon request.

### Dead End Chart (Double, Triple, & Quad Sheave Blocks\*)

Wireline Size (mm)	Dimensions (mm)		Recommended Wedge Socket	
	T Thickness	U Hole Diameter	McKissick® US-422 / US-422T Utility Socket	
			Stock No.	Size
11	25.4	32.5	1044309+	US4 11
13	25.4	32.5	1044318+	US4 13
14	25.4	32.5	1044336+	US5 14
16	25.4	32.5	1044345+	US5 16
19	31.8	42.2	1044363+	US6 19
22	31.8	42.2	1038580+	US7 22
25	31.8	42.2	1044417+	US8 25
28	44.5	65.0	1044426+	US10 28
32	44.5	65.0	1044435+	US10 32

\* To find Dead End Dimensions for Single Sheave blocks, refer to block tables on pages 313.

+ US-422T Terminator Style.



**380**  
Series Hook Block

The patented McKissick Split-Nut® is the standard retention system for standard crane blocks up to 100 Tons.

**For custom orders contact our Block Hotline at:**

(800) 727-1555 or refer to the special request form on page 454.



**381 – SINGLE**

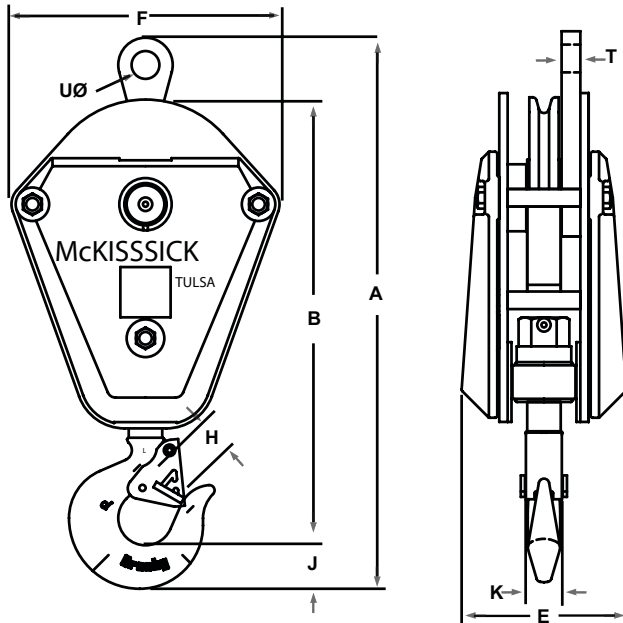

**382 – DOUBLE**

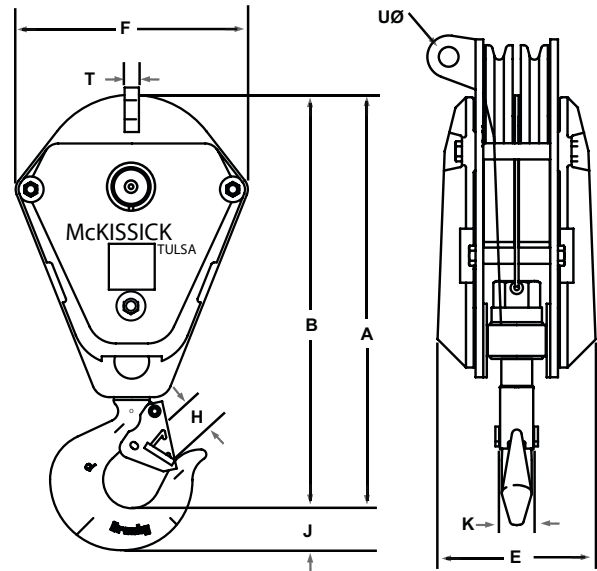

**383 – TRIPLE**

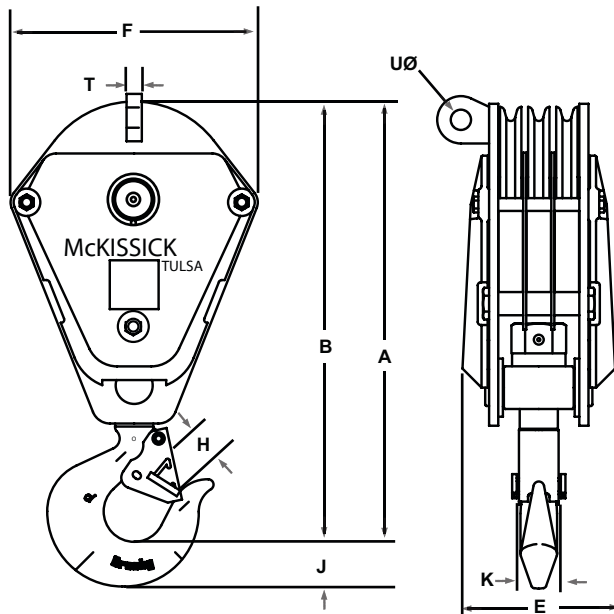

**384 – QUAD**

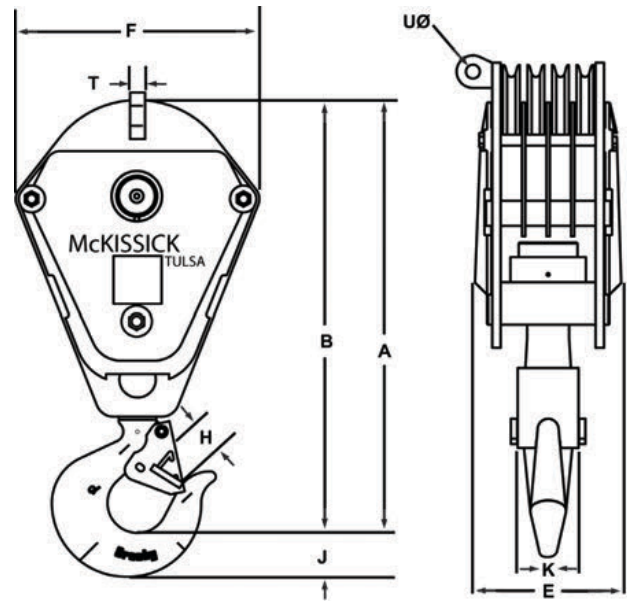

Thickness (E) shown is for blocks containing cheek weights (Light Medium - LM, Medium - M, and Heavy - H).  
The Thickness (E) for non weighted blocks (Light - L) is measured over side plates.

**385 – QUINTUPLE**

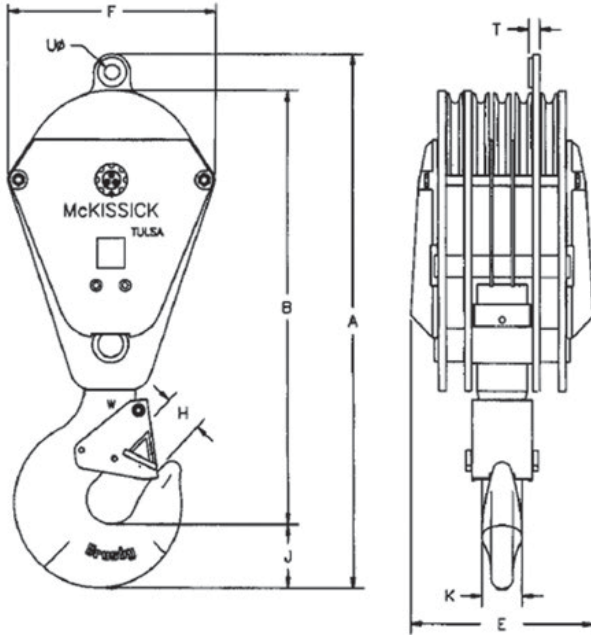

**386 – SEXTUPLE**

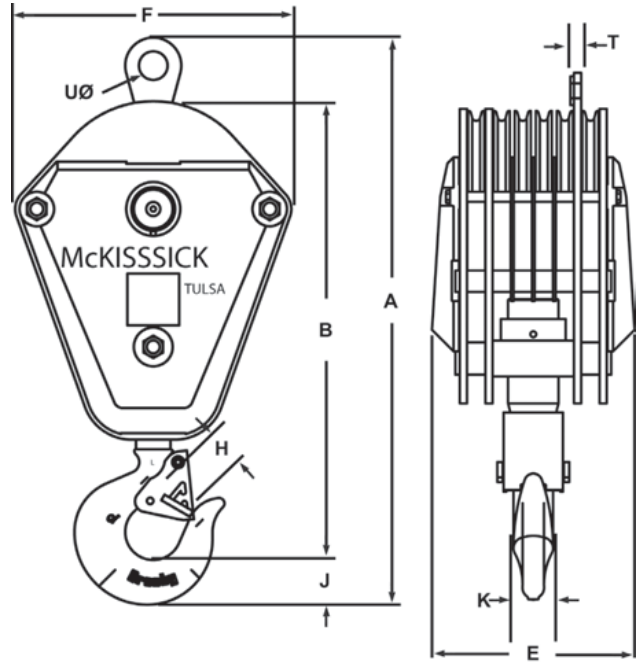

**387 – SEPTUPLE**

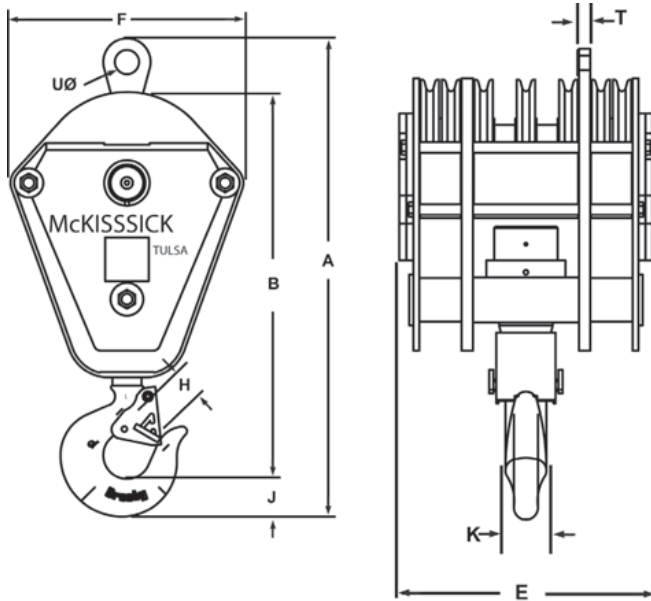

**388 – OCTUPLE**

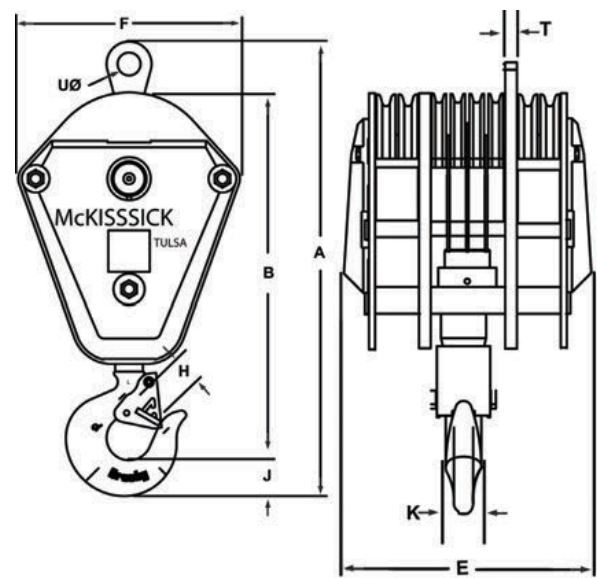

Thickness (E) shown is for blocks containing cheek weights (Light Medium - LM, Medium - M, and Heavy - H).  
The Thickness (E) for non weighted blocks (Light - L) is measured over side plates.



# McKissick® 380 Series Crane Blocks

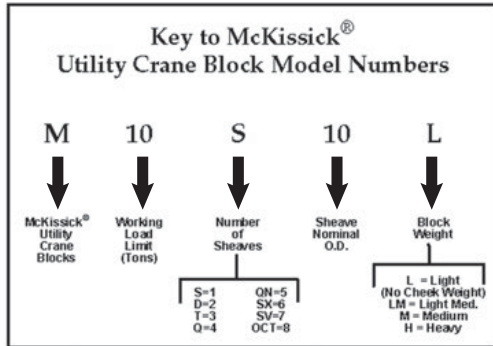

Sheave Diameter (in.)	Wireline Size (in.)										
	7/16	1/2	9/16	5/8	3/4	7/8	1	1 1/8	1 1/4	1 3/8	
10											
12											
14											
16											
18											
20											
24											
30											

\*For additional Wireline sizes, please call Crosby's Special Engineered Products Group at (1800) 777-1555.

## 380 Series Crane Blocks

- Specify Wireline size when ordering. For standard Wireline sizes, see Table 1.
- All sizes are **RFID EQUIPPED**.
- The patented McKissick Split-Nut® is the standard retention system for standard crane blocks up to 100 tons.

Model No.	Inquiry Stock No.	Working Load Limit (t) †	A Overall Length (mm)	B Net Length (mm)	E Thickness (mm)	F Width (mm)	H Throat Opening with Flapper (mm)	J Hook Thickness (mm)	K Hook Width (mm)	Standard Wireline Sizes (mm)*	Dead End ‡		Weight Each (kg)
											T Thickness (mm)	U Pin Hole (mm)	
<b>4.5 TONNES</b>													
M5S10L	2011004	4.5	788	631	136	356	48.5	66	49.3	11-16	28.7	35.8	64
M5S10M	2011013	4.5	788	631	217	356	48.5	66	49.3	11-16	28.7	35.8	91
M5S12L	2011022	4.5	835	675	136	406	48.5	66	49.3	13-19	28.7	35.8	64
M5S12M	2011031	4.5	835	675	250	406	48.5	66	49.3	13-19	28.7	35.8	122
M5S12H	2011036	4.5	835	675	352	406	48.5	66	49.3	13-19	28.7	35.8	181
M5D10L	2011037	4.5	697	631	136	356	48.5	66	49.3	11-16	—	—	73
M5D10M	2011038	4.5	697	631	217	356	48.5	66	49.3	11-16	—	—	101
<b>9 TONNES</b>													
M10S10L	2011040	9	788	631	136	356	48.5	66	49.3	11-16	28.7	35.8	61
M10S10M	2011049	9	788	631	217	356	48.5	66	49.3	11-16	28.7	35.8	90
M10S12L	2011058	9	835	675	136	356	48.5	66	49.3	13-19	28.7	35.8	66
M10S12M	2011067	9	835	675	250	356	48.5	66	49.3	13-19	28.7	35.8	122
M10S12H	2011071	9	835	675	352	356	48.5	66	49.3	13-19	28.7	35.8	197
M10S14L	2011076	9	892	733	136	457	48.5	66	49.3	13-19	28.7	35.8	82
M10S14LM	2011085	9	892	733	186	457	48.5	66	49.3	13-19	28.7	35.8	125
M10S14M	2011094	9	892	733	261	457	48.5	66	49.3	13-19	28.7	35.8	163
M10S14H	2011097	9	892	733	374	457	48.5	66	49.3	13-19	28.7	35.8	234
M10S16L	2011098	9	949	790	136	514	48.5	66	49.3	14-22	28.7	35.8	100
M10S16M	2011099	9	949	790	247	514	48.5	66	49.3	14-22	28.7	35.8	177
M10S16H	2011100	9	949	790	310	514	48.5	66	49.3	14-22	28.7	35.8	245
M10D10L	2011103	9	697	631	136	356	48.5	66	49.3	11-16	—	—	73
M10D10M	2011112	9	697	631	217	356	48.5	66	49.3	11-16	—	—	100
M10D12L	2011121	9	741	675	136	406	48.5	66	49.3	13-19	—	—	84
M10D12M	2011130	9	741	675	250	406	48.5	66	49.3	13-19	—	—	134
M10D12H	2011135	9	741	675	352	406	48.5	66	49.3	13-19	—	—	204
M10D14L	2011136	9	799	722	136	457	48.5	66	49.3	13-19	—	—	95
M10D14LM	2011141	9	799	722	186	457	48.5	66	49.3	13-19	—	—	141
M10D14M	2011137	9	799	722	261	457	48.5	66	49.3	13-19	—	—	180
M10D14H	2011138	9	799	722	374	457	48.5	66	49.3	13-19	—	—	254
M10T10L	2011139	9	700	634	195	356	48.5	66	49.3	11-16	—	—	91
M10T10M	2011140	9	700	634	282	356	48.5	66	49.3	11-16	—	—	120
<b>13.6 TONNES</b>													
M15S10L	2011148	13.6	788	631	136	356	48.5	66	49.3	11-16	35.1	42.2	62
M15S10M	2011157	13.6	788	631	217	356	48.5	66	49.3	11-16	35.1	42.2	91
M15S12L	2011166	13.6	835	675	136	406	48.5	66	49.3	13-19	35.1	42.2	66
M15S12M	2011175	13.6	835	675	250	406	48.5	66	49.3	13-19	35.1	42.2	134
M15S12H	2011179	13.6	835	675	352	406	48.5	66	49.3	13-19	35.1	42.2	197
M15S14L	2011184	13.6	892	733	136	457	48.5	66	49.3	13-19	35.1	42.2	86
M15S14LM	2011185	13.6	892	733	186	457	48.5	66	49.3	13-19	35.1	42.2	132
M15S14M	2011193	13.6	892	733	261	457	48.5	66	49.3	13-19	35.1	42.2	168
M15S14H	2011198	13.6	892	733	374	457	48.5	66	49.3	13-19	35.1	42.2	247
M15S16L	2011202	13.6	949	790	136	514	48.5	66	49.3	14-22	35.1	42.2	109
M15S16M	2011211	13.6	949	790	247	514	48.5	66	49.3	14-22	35.1	42.2	177
M15S16H	2011215	13.6	949	790	310	514	48.5	66	49.3	14-22	35.1	42.2	245
M15D10L	2011220	13.6	697	631	136	356	48.5	66	49.3	11-16	—	—	73
M15D10M	2011229	13.6	697	631	217	356	48.5	66	49.3	11-16	—	—	100

**MCKISSICK® BLOCKS**

## 380 Series Crane Blocks

Model No.	Inquiry Stock No.	Working Load Limit (t) †	A Overall Length (mm)	B Net Length (mm)	E Thickness (mm)	F Width (mm)	H Throat Opening with Flapper (mm)	J Hook Thickness (mm)	K Hook Width (mm)	Standard Wireline Sizes (mm)*	Dead End ‡		Weight Each (kg)
											T Thickness (mm)	U Pin Hole (mm)	
M15D12L	2011233	13.6	741	675	136	406	48.5	66	49.3	13-19	—	—	89
M15D12M	2011238	13.6	741	675	250	406	48.5	66	49.3	13-19	—	—	134
M15D12H	2011243	13.6	741	675	352	406	48.5	66	49.3	13-19	—	—	204
M15D14L	2011256	13.6	799	733	136	457	48.5	66	49.3	13-19	—	—	95
M15D14LM	2011257	13.6	799	733	186	457	48.5	66	49.3	13-19	—	—	141
M15D14M	2011265	13.6	799	733	261	457	48.5	66	49.3	13-19	—	—	180
M15D14H	2011269	13.6	799	733	374	457	48.5	66	49.3	13-19	—	—	254
M15D16L	2011270	13.6	856	790	136	514	48.5	66	49.3	14-22	—	—	136
M15D16M	2011271	13.6	856	790	247	514	48.5	66	49.3	14-22	—	—	211
M15D16H	2011272	13.6	856	790	310	514	48.5	66	49.3	14-22	—	—	277
M15T10L	2011273	13.6	700	634	195	356	48.5	66	49.3	11-16	—	—	91
M15T10M	2011274	13.6	700	634	282	356	48.5	66	49.3	11-16	—	—	120
M15T12L	2011275	13.6	744	679	195	406	48.5	66	49.3	13-19	—	—	98
M15T12M	2011283	13.6	744	679	310	406	48.5	66	49.3	13-19	—	—	154
M15T12H	2011285	13.6	744	679	411	406	48.5	66	49.3	13-19	—	—	225
M15Q10L	2011287	13.6	699	633	252	356	48.5	66	49.3	11-16	—	—	117
M15Q10M	2011288	13.6	699	633	333	356	48.5	66	49.3	11-16	—	—	145
<b>18 TONNES</b>													
M20S12L	2011289	18	884	714	148	406	70	75.5	60.5	13-19	35.1	42.2	91
M20S12M	2011290	18	884	714	263	406	70	75.5	60.5	13-19	35.1	42.2	140
M20S12H	2011291	18	884	714	364	406	70	75.5	60.5	13-19	35.1	42.2	213
M20S14L	2011301	18	941	772	148	457	70	75.5	60.5	13-19	35.1	42.2	109
M20S14LM	2011302	18	941	772	199	457	70	75.5	60.5	13-19	35.1	42.2	161
M20S14M	2011310	18	941	772	274	457	70	75.5	60.5	13-19	35.1	42.2	186
M20S14H	2011314	18	941	772	387	457	70	75.5	60.5	13-19	35.1	42.2	263
M20S16L	2011315	18	998	829	148	514	70	75.5	60.5	14-22	35.1	42.2	127
M20S16M	2011316	18	998	829	259	514	70	75.5	60.5	14-22	35.1	42.2	202
M20S16H	2011317	18	998	829	322	514	70	75.5	60.5	14-22	35.1	42.2	272
M20S18L	2011319	18	1125	929	174	578	70	75.5	60.5	16-25	38.9	52.3	181
M20S18M	2011328	18	1125	929	279	578	70	75.5	60.5	16-25	38.9	52.3	281
M20S18H	2011333	18	1125	929	329	578	70	75.5	60.5	16-25	38.9	52.3	345
M20S24L	2011330	18	1275	1078	174	730	70	75.5	60.5	22-32	35.1	42.2	247
M20S24M	2011331	18	1275	1078	371	730	70	75.5	60.5	22-32	35.1	42.2	534
M20S24H	2011332	18	1275	1078	472	730	70	75.5	60.5	22-32	35.1	42.2	753
M20D10L	2011335	18	746	670	148	356	70	75.5	60.5	11-16	—	—	91
M20D10M	2011337	18	746	670	229	356	70	75.5	60.5	11-16	—	—	118
M20D12L	2011346	18	790	714	148	406	70	75.5	60.5	13-19	—	—	103
M20D12M	2011355	18	790	714	263	406	70	75.5	60.5	13-19	—	—	154
M20D12H	2011364	18	790	714	364	406	70	75.5	60.5	13-19	—	—	229
M20D14L	2011373	18	848	772	148	457	70	75.5	60.5	13-19	—	—	127
M20D14LM	2011374	18	848	772	199	457	70	75.5	60.5	13-19	—	—	172
M20D14M	2011375	18	848	772	274	457	70	75.5	60.5	13-19	—	—	211
M20D14H	2011377	18	848	772	387	457	70	75.5	60.5	13-19	—	—	281
M20D16L	2011378	18	905	829	148	514	70	75.5	60.5	14-22	—	—	147
M20D16M	2011379	18	905	829	260	514	70	75.5	60.5	14-22	—	—	218
M20D16H	2011380	18	905	829	323	514	70	75.5	60.5	14-22	—	—	288
M20T10L	2011381	18	749	673	208	356	70	75.5	60.5	11-16	—	—	108
M20T10M	2011382	18	749	673	289	356	70	75.5	60.5	11-16	—	—	136
M20T12L	2011391	18	794	718	208	406	70	75.5	60.5	13-19	—	—	121
M20T12M	2011400	18	794	718	322	406	70	75.5	60.5	13-19	—	—	177
M20T12H	2011409	18	794	718	424	406	70	75.5	60.5	13-19	—	—	252
M20T14L	2011418	18	851	775	208	457	70	75.5	60.5	13-19	—	—	152
M20T14LM	2011420	18	851	775	259	457	70	75.5	60.5	13-19	—	—	195
M20T14M	2011427	18	851	775	332	457	70	75.5	60.5	13-19	—	—	236
M20T14H	2011432	18	851	775	445	457	70	75.5	60.5	13-19	—	—	306
M20Q10L	2011433	18	748	672	265	356	70	75.5	60.5	11-16	—	—	141
M20Q10M	2011434	18	748	672	346	356	70	75.5	60.5	11-16	—	—	163
M20Q12L	2011435	18	792	716	265	406	70	75.5	60.5	13-19	—	—	152
M20Q12M	2011436	18	792	716	379	406	70	75.5	60.5	13-19	—	—	222
M20Q12H	2011437	18	792	716	481	406	70	75.5	60.5	13-19	—	—	281
<b>23 TONNES @ - Ultimate Load is 3.6 times the Working Load Limit</b>													
M25S14L	2011441	23@	941	772	148	457	70	75.5	60.5	13-19	35.1	42.2	109
M25S14LM	2011443	23@	941	772	199	457	70	75.5	60.5	13-19	35.1	42.2	159
M25S14M	2011445	23@	941	772	274	457	70	75.5	60.5	13-19	35.1	42.2	188
M25S14H	2011448	23@	941	772	387	457	70	75.5	60.5	13-19	35.1	42.2	254
M25S16L	2011451	23@	998	829	148	514	70	75.5	60.5	14-22	38.1	42.2	127
M25S16M	2011454	23@	998	829	260	514	70	75.5	60.5	14-22	38.1	42.2	202
M25S16H	2011457	23@	998	829	323	514	70	75.5	60.5	14-22	38.1	42.2	268
M25S18L	2011461	23@	1125	929	174	578	70	75.5	60.5	16-25	38.9	52.5	177
M25S18M	2011463	23@	1125	929	279	578	70	75.5	60.5	16-25	38.9	52.5	281

# McKissick® 380 Series Crane Blocks



## 380 Series Crane Blocks

Model No.	Inquiry Stock No.	Working Load Limit (t) †	A Overall Length (mm)	B Net Length (mm)	E Thickness (mm)	F Width (mm)	H Throat Opening with Flapper (mm)	J Hook Thickness (mm)	K Hook Width (mm)	Standard Wireline Sizes (mm)*	Dead End ‡		Weight Each (kg)
											T Thickness (mm)	U Pin Hole (mm)	
M25S18H	2011467	23@	1125	929	329	578	70	75.5	60.5	16-25	38.9	52.5	345
M25S20L	2011458	23@	1173	976	174	629	70	75.5	60.5	19-28	38.1	52.5	197
M25S20M	2011459	23@	1173	976	288	629	70	75.5	60.5	19-28	38.1	52.5	297
M25S20H	2011460	23@	1173	976	390	629	70	75.5	60.5	19-28	38.1	52.5	364
M25S24L	2011464	23@	1275	1078	174	730	70	75.5	60.5	22-32	38.1	52.5	247
M25S24M	2011465	23@	1275	1078	371	730	70	75.5	60.5	22-32	38.1	52.5	535
M25S24H	2011466	23@	1275	1078	472	730	70	75.5	60.5	22-32	38.1	52.5	753
M25D12L	2011468	23@	790	714	148	406	70	75.5	60.5	13-19	—	—	103
M25D12M	2011469	23@	790	714	263	406	70	75.5	60.5	13-19	—	—	154
M25D12H	2011470	23@	790	714	364	406	70	75.5	60.5	13-19	—	—	229
M25D14L	2011472	23@	848	772	148	457	70	75.5	60.5	13-19	—	—	127
M25D14LM	2011481	23@	848	772	197	457	70	75.5	60.5	13-19	—	—	159
M25D14M	2011490	23@	848	772	274	457	70	75.5	60.5	13-19	—	—	211
M25D14H	2011495	23@	848	772	387	457	70	75.5	60.5	13-19	—	—	277
M25D16L	2011499	23@	905	829	148	514	70	75.5	60.5	14-22	—	—	147
M25D16M	2011508	23@	905	829	260	514	70	75.5	60.5	14-22	—	—	218
M25D16H	2011512	23@	905	829	323	514	70	75.5	60.5	14-22	—	—	288
M25D18L	2011576	23@	1003	927	174	578	70	75.5	60.5	16-25	—	—	213
M25D18M	2011579	23@	1003	927	279	578	70	75.5	60.5	16-25	—	—	320
M25D18H	2011581	23@	1003	927	329	578	70	75.5	60.5	16-25	—	—	381
M25T10L	2011514	23@	749	673	208	356	70	75.5	60.5	11-16	—	—	108
M25T10M	2011515	23@	749	673	289	356	70	75.5	60.5	11-16	—	—	136
M25T12L	2011517	23@	794	718	208	406	70	75.5	60.5	13-19	—	—	121
M25T12M	2011526	23@	794	718	322	406	70	75.5	60.5	13-19	—	—	177
M25T12H	2011531	23@	794	718	424	406	70	75.5	60.5	13-19	—	—	245
M25T14L	2011535	23@	851	775	208	457	70	75.5	60.5	13-19	—	—	152
M25T14LM	2011540	23@	851	775	259	457	70	75.5	60.5	13-19	—	—	225
M25T14M	2011544	23@	851	775	332	457	70	75.5	60.5	13-19	—	—	236
M25T14H	2011553	23@	851	775	445	457	70	75.5	60.5	13-19	—	—	306
M25T16L	2011562	23@	908	832	208	514	70	75.5	60.5	14-22	—	—	176
M25T16M	2011571	23@	908	832	318	514	70	75.5	60.5	14-22	—	—	252
M25T16H	2011575	23@	908	832	382	514	70	75.5	60.5	14-22	—	—	318
M25T18L	2011578	23@	1004	929	252	578	70	75.5	60.5	16-25	—	—	265
M25T18M	2011580	23@	1004	929	356	578	70	75.5	60.5	16-25	—	—	365
M25T18H	2011587	23@	1004	929	407	578	70	75.5	60.5	16-25	—	—	426
M25Q10L	2011588	23@	748	672	265	356	70	75.5	60.5	11-16	—	—	141
M25Q10M	2011589	23@	748	672	346	356	70	75.5	60.5	11-16	—	—	168
M25Q12L	2011590	23@	792	716	265	406	70	75.5	60.5	13-19	—	—	152
M25Q12M	2011591	23@	792	716	379	406	70	75.5	60.5	13-19	—	—	206
M25Q12H	2011592	23@	792	716	481	406	70	75.5	60.5	13-19	—	—	281
M25Q14L	2011593	23@	849	773	265	457	70	75.5	60.5	13-19	—	—	193
M25Q14LM	2011596	23@	849	773	316	457	70	75.5	60.5	13-19	—	—	220
M25Q14H	2011594	23@	849	773	391	457	70	75.5	60.5	13-19	—	—	273
M25Q14M	2011595	23@	849	773	503	457	70	75.5	60.5	13-19	—	—	340
<b>27 TONNES</b>													
M30S16L	2011598	27	1103	917	148	514	82.5	92	76	14-22	38.1	42.2	138
M30S16M	2011607	27	1103	917	260	514	82.5	92	76	14-22	38.1	42.2	211
M30S16H	2011613	27	1103	917	323	514	82.5	92	76	14-22	38.1	42.2	281
M30S18L	2011616	27	1168	955	174	578	82.5	92	76	16-25	38.9	52.5	191
M30S18M	2011625	27	1168	955	279	578	82.5	92	76	16-25	38.9	52.5	290
M30S18H	2011629	27	1168	955	329	578	82.5	92	76	16-25	38.9	52.5	351
M30S20L	2011631	27	1257	1044	174	629	82.5	92	76	19-28	38.1	52.5	212
M30S20M	2011634	27	1257	1044	288	629	82.5	92	76	19-28	38.1	52.5	347
M30S20H	2011638	27	1257	1044	390	629	82.5	92	76	19-28	38.1	52.5	508
M30S24L	2011639	27	1359	1145	174	730	82.5	92	76	22-32	38.1	52.5	336
M30S24M	2011640	27	1359	1145	371	730	82.5	92	76	22-32	38.1	52.5	640
M30S24H	2011641	27	1359	1145	472	730	82.5	92	76	22-32	38.1	52.5	857
M30D14L	2011643	27	952	860	148	457	82.5	92	76	13-19	—	—	135
M30D14LM	2011659	27	952	860	199	457	82.5	92	76	13-19	—	—	172
M30D14M	2011652	27	952	860	274	457	82.5	92	76	13-19	—	—	218
M30D14H	2011658	27	952	860	387	457	82.5	92	76	13-19	—	—	293
M30D16L	2011661	27	1009	917	148	514	82.5	92	76	14-22	—	—	159
M30D16M	2011670	27	1009	917	260	514	82.5	92	76	14-22	—	—	230
M30D16H	2011672	27	1009	917	323	514	82.5	92	76	14-22	—	—	297
M30D18L	2011675	27	1048	955	174	578	82.5	92	76	16-25	—	—	222
M30D18M	2011676	27	1048	955	279	578	82.5	92	76	16-25	—	—	322
M30D18H	2011677	27	1048	955	329	578	82.5	92	76	16-25	—	—	383
M30T12L	2011679	27	895	802	208	406	82.5	92	76	13-19	—	—	145
M30T12M	2011680	27	895	802	322	406	82.5	92	76	13-19	—	—	201
M30T12H	2011681	27	895	802	424	406	82.5	92	76	13-19	—	—	270

**McKISSICK® BLOCKS**



**380 Series Crane Blocks**

Model No.	Inquiry Stock No.	Working Load Limit (t) †	A Overall Length (mm)	B Net Length (mm)	E Thickness (mm)	F Width (mm)	H Throat Opening with Flapper (mm)	J Hook Thickness (mm)	K Hook Width (mm)	Standard Wireline Sizes (mm)*	Dead End ‡		Weight Each (kg)
											T Thickness (mm)	U Pin Hole (mm)	
M30T14L	2011688	27	953	860	208	457	82.5	92	76	13-19	—	—	177
M30T14LM	2011703	27	953	860	257	457	82.5	92	76	13-19	—	—	218
M30T14M	2011697	27	953	860	332	457	82.5	92	76	13-19	—	—	261
M30T14H	2011702	27	953	860	445	457	82.5	92	76	13-19	—	—	337
M30T16L	2011706	27	1010	917	208	514	82.5	92	76	14-22	—	—	206
M30T16M	2011708	27	1010	917	318	514	82.5	92	76	14-22	—	—	277
M30T16H	2011710	27	1010	917	382	514	82.5	92	76	14-22	—	—	342
M30T18L	2011712	27	1048	955	252	578	82.5	92	76	16-25	—	—	281
M30T18M	2011715	27	1048	955	356	578	82.5	92	76	16-25	—	—	388
M30T18H	2011719	27	1048	955	407	578	82.5	92	76	16-25	—	—	449
M30T20L	2011742	27	1099	1006	252	629	82.5	92	76	19-28	—	—	312
M30T20M	2011743	27	1099	1006	366	629	82.5	92	76	19-28	—	—	449
M30T20H	2011744	27	1099	1006	468	629	82.5	92	76	19-28	—	—	608
M30Q10L	2011714	27	851	758	265	356	82.5	92	76	11-16	—	—	159
M30Q10M	2011716	27	851	758	346	356	82.5	92	76	11-16	—	—	184
M30Q12L	2011717	27	895	802	265	406	82.5	92	76	13-19	—	—	168
M30Q12M	2011718	27	895	802	379	406	82.5	92	76	13-19	—	—	225
M30Q12H	2011720	27	895	802	481	406	82.5	92	76	13-19	—	—	297
M30Q14L	2011724	27	953	860	265	457	82.5	92	76	13-19	—	—	206
M30Q14LM	2011741	27	953	860	316	457	82.5	92	76	13-19	—	—	236
M30Q14M	2011733	27	953	860	392	457	82.5	92	76	13-19	—	—	290
M30Q14H	2011737	27	953	860	505	457	82.5	92	76	13-19	—	—	362
M30Q16L	2011738	27	1010	917	265	514	82.5	92	76	14-22	—	—	195
M30Q16M	2011739	27	1010	917	378	514	82.5	92	76	14-22	—	—	265
M30Q16H	2011740	27	1010	917	441	514	82.5	92	76	14-22	—	—	332
<b>32 TONNES</b>													
M35S18L	2011745	32	1270	1034	174	578	76	116	92	16-25	38.1	52.5	272
M35S18M	2011746	32	1270	1034	279	578	76	116	92	16-25	38.1	52.5	332
M35S18H	2011747	32	1270	1034	329	578	76	116	92	16-25	38.1	52.5	392
M35S20L	2011748	32	1359	1122	174	629	76	116	92	19-28	38.1	52.5	244
M35S20M	2011751	32	1359	1130	288	629	76	116	92	19-28	38.1	52.5	379
M35S20H	2011755	32	1359	1122	390	629	76	116	92	19-28	38.1	52.5	536
M35S24L	2011752	32	1461	1224	174	730	76	116	92	22-32	38.1	52.5	336
M35S24M	2011753	32	1461	1224	371	730	76	116	92	22-32	38.1	52.5	640
M35S24H	2011754	32	1461	1224	472	730	76	116	92	22-32	38.1	52.5	857
M35D16L	2011756	32	1111	995	174	514	76	116	92	14-22	—	—	195
M35D16M	2011757	32	1111	995	285	514	76	116	92	14-22	—	—	265
M35D16H	2011758	32	1111	995	348	514	76	116	92	14-22	—	—	332
M35D18L	2011760	32	1047	955	252	578	76	116	92	16-25	—	—	254
M35D18M	2011769	32	1047	955	356	578	76	116	92	16-25	—	—	365
M35D18H	2011774	32	1047	955	407	578	76	116	92	16-25	—	—	424
M35T14L	2011778	32	1056	938	208	457	76	116	92	13-19	—	—	204
M35T14LM	2011792	32	1056	938	259	457	76	116	92	13-19	—	—	245
M35T14M	2011787	32	1056	938	332	457	76	116	92	13-19	—	—	286
M35T14H	2011793	32	1056	938	445	457	76	116	92	13-19	—	—	357
M35T16L	2011794	32	1113	995	208	514	76	116	92	14-22	—	—	227
M35T16M	2011795	32	1113	995	318	514	76	116	92	14-22	—	—	303
M35T16H	2011796	32	1113	995	382	514	76	116	92	14-22	—	—	365
M35T18L	2011797	32	1149	1034	252	578	76	116	92	16-25	—	—	308
M35T18M	2011799	32	1149	1034	356	578	76	116	92	16-25	—	—	408
M35T18H	2011802	32	1149	1034	407	578	76	116	92	16-25	—	—	469
M35T20L	2011798	32	1238	1122	252	629	76	116	92	19-28	—	—	338
M35T20M	2011800	32	1238	1122	366	629	76	116	92	19-28	—	—	479
M35T20H	2011801	32	1238	1122	468	629	76	116	92	19-28	—	—	635
M35Q12L	2011803	32	998	881	265	406	76	116	92	13-19	—	—	199
M35Q12M	2011804	32	998	881	379	406	76	116	92	13-19	—	—	252
M35Q12H	2011805	32	998	881	481	406	76	116	92	13-19	—	—	322
M35Q14L	2011806	32	1056	938	265	457	76	116	92	13-19	—	—	206
M35Q14LM	2011807	32	1056	938	316	457	76	116	92	13-19	—	—	236
M35Q14M	2011814	32	1056	938	392	457	76	116	92	13-19	—	—	294
M35Q14H	2011817	32	1056	938	505	457	76	116	92	13-19	—	—	370
M35Q16L	2011818	32	1113	995	265	514	76	116	92	14-22	—	—	265
M35Q16M	2011819	32	1113	995	378	514	76	116	92	14-22	—	—	340
M35Q16H	2011820	32	1113	995	441	514	76	116	92	14-22	—	—	404
M35QN14L	2011815	32	1143	938	337	457	76	116	92	13-19	31.8	35.8	240
M35QN14LM	2011808	32	1143	938	387	457	76	116	92	13-19	31.8	35.8	281
M35QN14M	2011809	32	1143	938	464	457	76	116	92	13-19	31.8	35.8	367
M35QN14H	2011810	32	1143	938	500	457	76	116	92	13-19	31.8	35.8	435
<b>36 TONNES</b>													
M40S20L	2011833	36	1418	1168	198	629	76	116	92	19-28	44.5	58	299

# McKissick® 380 Series Crane Blocks



## 380 Series Crane Blocks

Model No.	Inquiry Stock No.	Working Load Limit (t) †	A Overall Length (mm)	B Net Length (mm)	E Thickness (mm)	F Width (mm)	H Throat Opening with Flapper (mm)	J Hook Thickness (mm)	K Hook Width (mm)	Standard Wireline Sizes (mm)*	Dead End ‡		Weight Each (kg)
											T Thickness (mm)	U Pin Hole (mm)	
M40S20M	2011834	36	1418	1168	313	629	76	116	92	19-28	44.5	58	433
M40S20H	2011835	36	1418	1168	414	629	86	129	94.5	19-28	44.5	58	589
M40S24L	2011825	36	1519	1270	198	730	86	129	94.5	22-32	44.5	58	358
M40S24M	2011829	36	1519	1270	395	730	86	129	94.5	22-32	44.5	58	671
M40S24H	2011832	36	1519	1270	497	730	86	129	94.5	22-32	44.5	58	880
M40D18L	2011918	36	1208	1080	198	578	86	129	94.5	16-25	—	—	311
M40D18M	2011919	36	1208	1080	303	578	86	129	94.5	16-25	—	—	420
M40D18H	2011920	36	1208	1080	354	578	86	129	94.5	16-25	—	—	487
M40D20L	2011841	36	1272	1143	198	629	86	129	94.5	19-28	—	—	344
M40D20M	2011850	36	1272	1143	313	629	86	129	94.5	19-28	—	—	494
M40D20H	2011854	36	1272	1143	414	629	86	129	94.5	19-28	—	—	635
M40T14L	2011855	36	1103	975	208	457	86	129	94.5	13-19	—	—	235
M40T14M	2011856	36	1103	975	332	457	86	129	94.5	13-19	—	—	315
M40T14H	2011857	36	1103	975	445	457	86	129	94.5	13-19	—	—	382
M40T16L	2011859	36	1161	1032	208	514	86	129	94.5	14-22	—	—	238
M40T16M	2011868	36	1161	1032	318	514	86	129	94.5	14-22	—	—	313
M40T16H	2011871	36	1161	1032	382	514	86	129	94.5	14-22	—	—	379
M40T18L	2011874	36	1202	1073	264	578	86	129	94.5	16-25	—	—	362
M40T18M	2011877	36	1202	1073	368	578	86	129	94.5	16-25	—	—	462
M40T18H	2011881	36	1202	1073	419	578	86	129	94.5	16-25	—	—	525
M40T20L	2011882	36	1272	1143	264	629	86	129	94.5	19-28	—	—	403
M40T20M	2011883	36	1272	1143	378	629	86	129	94.5	19-28	—	—	538
M40T20H	2011884	36	1272	1143	480	629	86	129	94.5	19-28	—	—	694
M40Q14L	2011885	36	1103	975	265	457	86	129	94.5	13-19	—	—	243
M40Q14M	2011886	36	1103	975	392	457	86	129	94.5	13-19	—	—	338
M40Q14H	2011891	36	1103	975	429	457	86	129	94.5	13-19	—	—	413
M40Q16L	2011895	36	1161	1032	265	514	86	129	94.5	14-22	—	—	284
M40Q16M	2011904	36	1161	1032	378	514	86	129	94.5	14-22	—	—	356
M40Q16H	2011908	36	1161	1032	441	514	86	129	94.5	14-22	—	—	422
M40Q18L	2011910	36	1202	1073	338	578	86	129	94.5	16-25	—	—	422
M40Q18M	2011913	36	1202	1073	443	578	86	129	94.5	16-25	—	—	522
M40Q18H	2011917	36	1202	1073	494	578	86	129	94.5	16-25	—	—	585
M40QN14L	2011921	36	1194	988	337	457	86	129	94.5	13-19	31.8	35.8	231
M40QN14M	2011922	36	1194	988	464	457	86	129	94.5	13-19	31.8	35.8	333
M40QN14H	2011923	36	1194	988	500	457	86	129	94.5	13-19	31.8	35.8	408
<b>40 TONNES @ - Ultimate Load is 3.6 times the Working Load Limit</b>													
M45S24L	2011924	40@	1519	1270	198	730	86	129	94.5	22-32	44.5	58	365
M45S24M	2011925	40@	1519	1270	395	730	86	129	94.5	22-32	44.5	58	655
M45S24H	2011926	40@	1519	1270	497	730	86	129	94.5	22-32	44.5	58	880
M45D20L	2011928	40@	1272	1143	198	629	86	129	94.5	19-28	—	—	344
M45D20M	2011931	40@	1272	1143	313	629	86	129	94.5	19-28	—	—	479
M45D20H	2011937	40@	1272	1143	414	629	86	129	94.5	19-28	—	—	635
M45T16L	2011942	40@	1161	1032	208	514	86	129	94.5	14-22	—	—	238
M45T16M	2011951	40@	1161	1032	318	514	86	129	94.5	14-22	—	—	313
M45T16H	2011960	40@	1161	1032	382	514	86	129	94.5	14-22	—	—	379
M45T18L	2011969	40@	1202	1073	264	578	86	129	94.5	16-25	—	—	362
M45T18M	2011978	40@	1202	1073	368	578	86	129	94.5	16-25	—	—	462
M45T18H	2011987	40@	1202	1073	419	578	86	129	94.5	16-25	—	—	525
M45T20L	2011993	40@	1272	1143	264	629	86	129	94.5	19-28	—	—	403
M45T20M	2011996	40@	1272	1143	378	629	86	129	94.5	19-28	—	—	538
M45T20H	2012000	40@	1272	1143	480	629	86	129	94.5	19-28	—	—	694
M45Q14L	2012001	40@	1103	975	265	457	86	129	94.5	13-19	—	—	243
M45Q14M	2012003	40@	1103	975	392	457	86	129	94.5	13-19	—	—	338
M45Q14H	2012004	40@	1103	975	429	457	86	129	94.5	13-19	—	—	413
M45Q16L	2012005	40@	1161	1032	265	514	86	129	94.5	14-22	—	—	284
M45Q16M	2012006	40@	1161	1032	378	514	86	129	94.5	14-22	—	—	356
M45Q16H	2012007	40@	1161	1032	441	514	86	129	94.5	14-22	—	—	422
M45Q18L	2012008	40@	1202	1073	338	578	86	129	94.5	16-25	—	—	422
M45Q18M	2012009	40@	1202	1073	443	578	86	129	94.5	16-25	—	—	522
M45Q18H	2012010	40@	1202	1073	494	578	86	129	94.5	16-25	—	—	585
M45QN16L	2011997	40@	1249	1032	337	514	86	129	94.5	14-22	31.8	36.6	302
M45QN16M	2011998	40@	1249	1032	448	514	86	129	94.5	14-22	31.8	36.6	373
M45QN16H	2011999	40@	1249	1032	511	514	86	129	94.5	14-22	31.8	36.6	439
<b>45 TONNES</b>													
M50S24L	2012015	45	1629	1349	198	730	105	152	113	22-32	51	64.5	435
M50S24M	2012015	45	1629	1349	395	730	105	152	113	22-32	51	64.5	710
M50S24H	2012017	45	1629	1349	497	730	105	152	113	22-32	51	64.5	941
M50D24L	2012018	45	1502	1349	198	730	105	152	113	22-32	—	—	517
M50D24M	2012019	45	1502	1349	395	730	105	152	113	22-32	—	—	803
M50D24H	2012020	45	1502	1349	497	730	105	152	113	22-32	—	—	1021

**McKISSICK® BLOCKS**

380 Series Crane Blocks

Model No.	Inquiry Stock No.	Working Load Limit (t) †	A Overall Length (mm)	B Net Length (mm)	E Thickness (mm)	F Width (mm)	H Throat Opening with Flapper (mm)	J Hook Thickness (mm)	K Hook Width (mm)	Standard Wireline Sizes (mm)*	Dead End ‡		Weight Each (kg)
											T Thickness (mm)	U Pin Hole (mm)	
M50T18L	2012014	45	1362	1210	264	578	105	152	113	16-25	—	—	422
M50T18M	2012023	45	1362	1210	368	578	105	152	113	16-25	—	—	499
M50T18H	2012027	45	1362	1210	419	578	105	152	113	16-25	—	—	562
M50T20L	2012032	45	1375	1222	264	629	105	152	113	19-28	—	—	449
M50T20M	2012041	45	1375	1222	378	629	105	152	113	19-28	—	—	587
M50T20H	2012045	45	1375	1222	480	629	105	152	113	19-28	—	—	742
M50T24L	2012048	45	1502	1349	264	730	105	152	113	22-32	—	—	544
M50T24M	2012050	45	1502	1349	461	730	105	152	113	22-32	—	—	857
M50T24H	2012055	45	1502	1349	562	730	105	152	113	22-32	—	—	1074
M50Q16L	2012059	45	1267	1115	338	514	105	152	113	14-22	—	—	369
M50Q16M	2012068	45	1267	1115	449	514	105	152	113	14-22	—	—	445
M50Q16H	2012073	45	1267	1115	513	514	105	152	113	14-22	—	—	510
M50Q18L	2012077	45	1362	1286	338	578	105	152	113	16-25	—	—	451
M50Q18M	2012086	45	1362	1286	443	578	105	152	113	16-25	—	—	553
M50Q18H	2012091	45	1362	1286	494	578	105	152	113	16-25	—	—	617
M50Q20L	2012095	45	1375	1223	338	629	105	152	113	19-28	—	—	517
M50Q20M	2012097	45	1375	1223	452	629	105	152	113	19-28	—	—	676
M50Q20H	2012101	45	1375	1223	554	629	105	152	113	19-28	—	—	853
M50QN14L	2012056	45	1314	1064	337	457	105	152	113	13-19	31.8	35.8	365
M50QN14M	2012057	45	1314	1064	462	457	105	152	113	13-19	31.8	35.8	435
M50QN14H	2012058	45	1314	1064	575	457	105	152	113	13-19	31.8	35.8	538
M50QN16L	2012060	45	1372	1115	337	514	105	152	113	14-22	31.8	35.8	397
M50QN16M	2012061	45	1372	1115	448	514	105	152	113	14-22	31.8	35.8	467
M50QN16H	2012062	45	1372	1115	511	514	105	152	113	14-22	31.8	35.8	535
M50SX14L	2012063	45	1314	1064	394	457	105	152	113	13-19	31.8	35.8	420
M50SX14M	2012064	45	1314	1064	521	457	105	152	113	13-19	31.8	35.8	463
M50SX14H	2012065	45	1314	1064	633	457	105	152	113	13-19	31.8	35.8	567
<b>50 TONNES</b>													
M55S24L	2012105	50	1629	1349	198	730	105	152	113	22-32	51	64.5	435
M55S24M	2012106	50	1629	1349	395	730	105	152	113	22-32	51	64.5	723
M55S24H	2012107	50	1629	1349	497	730	105	152	113	22-32	51	64.5	941
M55D24L	2012108	50	1502	1349	198	730	105	152	113	22-32	—	—	517
M55D24M	2012109	50	1502	1349	395	730	105	152	113	22-32	—	—	803
M55D24H	2012110	50	1502	1349	497	730	105	152	113	22-32	—	—	1021
M55T18L	2012104	50	1362	1210	264	578	105	152	113	16-25	—	—	399
M55T18M	2012113	50	1362	1210	368	578	105	152	113	16-25	—	—	499
M55T18H	2012122	50	1362	1210	419	578	105	152	113	16-25	—	—	562
M55T20L	2012111	50	1375	1222	264	629	105	152	113	19-28	—	—	449
M55T20M	2012114	50	1375	1222	378	629	105	152	113	19-28	—	—	587
M55T20H	2012123	50	1375	1222	480	629	105	152	113	19-28	—	—	742
M55T24L	2012112	50	1502	1349	264	730	105	152	113	22-32	—	—	544
M55T24M	2012124	50	1502	1349	461	730	105	152	113	22-32	—	—	857
M55T24H	2012125	50	1502	1349	562	730	105	152	113	22-32	—	—	1074
M55Q16L	2012131	50	1267	1115	338	514	105	152	113	14-22	—	—	369
M55Q16M	2012140	50	1267	1115	449	514	105	152	113	14-22	—	—	445
M55Q16H	2012143	50	1267	1115	513	514	105	152	113	14-22	—	—	510
M55Q18L	2012146	50	1362	1286	338	578	105	152	113	16-25	—	—	451
M55Q18M	2012149	50	1362	1286	443	578	105	152	113	16-25	—	—	553
M55Q18H	2012153	50	1362	1286	494	578	105	152	113	16-25	—	—	617
M55Q20L	2012171	50	1375	1222	338	629	105	152	113	19-28	—	—	517
M55Q20M	2012172	50	1375	1222	452	629	105	152	113	19-28	—	—	676
M55Q20H	2012173	50	1375	1222	579	629	105	152	113	19-28	—	—	841
M55QN14L	2012126	50	1314	1064	337	457	105	152	113	13-19	31.8	35.8	381
M55QN14M	2012127	50	1314	1064	464	457	105	152	113	13-19	31.8	35.8	469
M55QN14H	2012128	50	1314	1064	575	457	105	152	113	13-19	31.8	35.8	538
M55QN16L	2012158	50	1372	1115	337	514	105	152	113	14-22	31.8	35.8	397
M55QN16M	2012167	50	1372	1115	448	514	105	152	113	14-22	31.8	35.8	467
M55QN16H	2012170	50	1372	1115	511	514	105	152	113	14-22	31.8	35.8	535
M55QN18L	2012147	50	1489	1210	445	578	105	152	113	16-25	31.8	35.8	626
M55QN18M	2012150	50	1489	1210	549	578	105	152	113	16-25	31.8	35.8	726
M55QN18H	2012154	50	1489	1210	600	578	105	152	113	16-25	31.8	35.8	794
M55SX14L	2012135	50	1314	1064	394	457	105	152	113	13-19	31.8	35.8	420
M55SX14M	2012141	50	1314	1064	520	457	105	152	113	13-19	31.8	35.8	463
M55SX14H	2012144	50	1314	1064	633	457	105	152	113	13-19	31.8	35.8	567
<b>54 TONNES</b>													
M60D24L	2012175	54	1502	1349	198	730	105	152	113	22-32	—	—	517
M60D24M	2012179	54	1502	1349	313	730	105	152	113	22-32	—	—	803
M60D24H	2012183	54	1502	1349	497	730	105	152	113	22-32	—	—	1021
M60T18L	2012187	54	1362	1210	264	578	105	152	113	16-25	—	—	400
M60T18M	2012191	54	1362	1210	368	578	105	152	113	16-25	—	—	506



# McKissick® 380 Series Crane Blocks



## 380 Series Crane Blocks

Model No.	Inquiry Stock No.	Working Load Limit (t) †	A Overall Length (mm)	B Net Length (mm)	E Thickness (mm)	F Width (mm)	H Throat Opening with Flapper (mm)	J Hook Thickness (mm)	K Hook Width (mm)	Standard Wireline Sizes (mm)*	Dead End ‡		Weight Each (kg)
											T Thickness (mm)	U Pin Hole (mm)	
M60T18H	2012195	54	1362	1210	419	578	105	152	113	16-25	—	—	562
M60T20L	2012199	54	1375	1222	264	629	105	152	113	19-28	—	—	431
M60T20M	2012203	54	1375	1222	378	629	105	152	113	19-28	—	—	603
M60T20H	2012207	54	1375	1222	480	629	105	152	113	19-28	—	—	769
M60T24L	2012211	54	1502	1349	262	730	105	152	113	22-32	—	—	569
M60T24M	2012215	54	1502	1349	460	730	105	152	113	22-32	—	—	857
M60T24H	2012219	54	1502	1349	559	730	105	152	113	22-32	—	—	1073
M60Q16L	2012223	54	1267	1115	338	514	105	152	113	14-22	—	—	411
M60Q16M	2012227	54	1267	1115	449	514	105	152	113	14-22	—	—	467
M60Q16H	2012231	54	1267	1115	513	514	105	152	113	14-22	—	—	553
M60Q18L	2012235	54	1362	1210	338	578	105	152	113	16-25	—	—	454
M60Q18M	2012239	54	1362	1210	443	578	105	152	113	16-25	—	—	557
M60Q18H	2012243	54	1362	1210	494	578	105	152	113	16-25	—	—	620
M60Q20L	2012247	54	1375	1222	338	629	105	152	113	19-28	—	—	517
M60Q20M	2012251	54	1375	1222	452	629	105	152	113	19-28	—	—	676
M60Q20H	2012255	54	1375	1222	554	629	105	152	113	19-28	—	—	841
M60Q24L	2012259	54	1502	1349	338	730	105	152	113	22-32	—	—	659
M60Q24M	2012263	54	1502	1349	535	730	105	152	113	22-32	—	—	962
M60Q24H	2012267	54	1502	1349	637	730	105	152	113	22-32	—	—	1179
M60QN20L	2012271	54	1502	1222	445	629	105	152	113	19-28	38.1	35.8	710
M60QN20M	2012275	54	1502	1222	559	629	105	152	113	19-28	38.1	35.8	844
M60QN20H	2012279	54	1502	1222	660	629	105	152	113	19-28	38.1	35.8	1002
M60SX14L	2012283	54	1314	1162	394	457	105	152	113	13-19	31.8	35.8	420
M60SX14M	2012287	54	1314	1162	520	457	105	152	113	13-19	31.8	35.8	499
M60SX14H	2012291	54	1314	1162	631	457	105	152	113	13-19	31.8	35.8	567
M60SX18L	2012295	54	1489	1210	496	578	105	152	113	16-25	38.1	52.5	640
M60SX18M	2012299	54	1489	1210	601	578	105	152	113	16-25	38.1	52.5	748
M60SX18H	2012303	54	1489	1210	652	578	105	152	113	16-25	38.1	52.5	816
<b>59 TONNES</b>													
M65D24L	2012376	59	1502	1349	198	730	105	152	113	22-32	—	—	517
M65D24M	2012377	59	1502	1349	395	730	105	152	113	22-32	—	—	803
M65D24H	2012378	59	1502	1349	497	730	105	152	113	22-32	—	—	1021
M65T18L	2012304	59	1362	1210	264	578	105	152	113	16-25	—	—	422
M65T18M	2012305	59	1362	1210	368	578	105	152	113	16-25	—	—	499
M65T18H	2012306	59	1362	1210	419	578	105	152	113	16-25	—	—	590
M65T20L	2012307	59	1375	1222	264	629	105	152	113	19-28	—	—	451
M65T20M	2012311	59	1375	1222	378	629	105	152	113	19-28	—	—	590
M65T20H	2012315	59	1375	1222	480	629	105	152	113	19-28	—	—	742
M65T24L	2012316	59	1502	1349	264	730	105	152	113	22-32	—	—	569
M65T24M	2012317	59	1502	1349	460	730	105	152	113	22-32	—	—	857
M65T24H	2012318	59	1502	1349	562	730	105	152	113	22-32	—	—	1073
M65Q16L	2012312	59	1267	1115	338	514	105	152	113	14-22	—	—	411
M65Q16M	2012313	59	1267	1115	449	514	105	152	113	14-22	—	—	467
M65Q16H	2012314	59	1267	1115	513	514	105	152	113	14-22	—	—	553
M65Q18L	2012340	59	1362	1210	338	578	105	152	113	16-25	—	—	481
M65Q18M	2012341	59	1362	1210	443	578	105	152	113	16-25	—	—	551
M65Q18H	2012342	59	1362	1210	494	578	105	152	113	16-25	—	—	649
M65Q20L	2012319	59	1375	1222	338	629	105	152	113	19-28	—	—	517
M65Q20M	2012323	59	1375	1222	452	629	105	152	113	19-28	—	—	676
M65Q20H	2012327	59	1375	1222	554	629	105	152	113	19-28	—	—	841
M65Q24L	2012328	59	1502	1349	338	730	105	152	113	22-32	—	—	659
M65Q24M	2012329	59	1502	1349	535	730	105	152	113	22-32	—	—	962
M65Q24H	2012330	59	1502	1349	637	730	105	152	113	22-32	—	—	1179
M65QN16L	2012331	59	1445	1165	445	514	105	152	113	14-22	38.1	35.8	401
M65QN16M	2012335	59	1445	1165	556	514	105	152	113	14-22	38.1	35.8	475
M65QN16H	2012339	59	1445	1165	619	514	105	152	113	14-22	38.1	35.8	544
M65QN18L	2012343	59	1489	1210	445	578	105	152	113	16-25	38.1	35.8	626
M65QN18M	2012347	59	1489	1210	549	578	105	152	113	16-25	38.1	35.8	726
M65QN18H	2012351	59	1489	1210	600	578	105	152	113	16-25	38.1	35.8	793
M65QN20L	2012355	59	1502	1222	445	629	105	152	113	19-28	38.1	35.8	710
M65QN20M	2012359	59	1502	1222	559	629	105	152	113	19-28	38.1	35.8	844
M65QN20H	2012363	59	1502	1222	660	629	105	152	113	19-28	38.1	35.8	1002
M65QN24L	2012364	59	1591	1311	445	730	105	152	113	22-32	38.1	35.8	831
M65QN24M	2012368	59	1591	1311	641	730	105	152	113	22-32	38.1	35.8	1150
M65QN24H	2012372	59	1591	1311	743	730	105	152	113	22-32	38.1	35.8	1360
M65SX16L	2012352	59	1445	1165	496	514	105	152	113	14-22	38.1	52.5	531
M65SX16M	2012353	59	1445	1165	607	514	105	152	113	14-22	38.1	52.5	606
M65SX16H	2012354	59	1445	1165	671	514	105	152	113	14-22	38.1	52.5	674
M65SX18L	2012356	59	1489	1210	496	578	105	152	113	16-25	38.1	52.5	640
M65SX18M	2012357	59	1489	1210	601	578	105	152	113	16-25	38.1	52.5	748

**McKISSICK® BLOCKS**

**380 Series Crane Blocks**

Model No.	Inquiry Stock No.	Working Load Limit (t) †	A Overall Length (mm)	B Net Length (mm)	E Thickness (mm)	F Width (mm)	H Throat Opening with Flapper (mm)	J Hook Thickness (mm)	K Hook Width (mm)	Standard Wireline Sizes (mm)*	Dead End ‡		Weight Each (kg)
											T Thickness (mm)	U Pin Hole (mm)	
M65SX18H	2012358	59	1489	1210	652	578	105	152	113	16-25	38.1	52.5	816
M65SX20L	2012367	59	1502	1222	496	629	105	152	113	19-28	38.1	52.5	737
M65SX20M	2012371	59	1502	1222	610	629	105	152	113	19-28	38.1	52.5	871
M65SX20H	2012375	59	1502	1222	712	629	105	152	113	19-28	38.1	52.5	1031
<b>63 TONNES</b>													
M70D24L	2012379	63	1637	1467	282	730	137	170	108	22-32	—	—	690
M70D24M	2012383	63	1637	1467	479	730	137	170	108	22-32	—	—	993
M70D24H	2012387	63	1637	1467	580	730	137	170	108	22-32	—	—	1211
M70T18L	2012391	63	1497	1327	282	578	137	170	108	16-25	—	—	572
M70T18M	2012395	63	1497	1327	387	578	137	170	108	16-25	—	—	680
M70T18H	2012399	63	1497	1327	438	578	137	170	108	16-25	—	—	748
M70T20L	2012403	63	1548	1378	282	629	137	170	108	19-28	—	—	641
M70T20M	2012407	63	1548	1378	397	629	137	170	108	19-28	—	—	776
M70T20H	2012411	63	1548	1378	489	629	137	170	108	19-28	—	—	935
M70T24L	2012415	63	1637	1467	282	730	137	170	108	22-32	—	—	745
M70T24M	2012419	63	1637	1467	480	730	137	170	108	22-32	—	—	1040
M70T24H	2012423	63	1637	1467	581	730	137	170	108	22-32	—	—	1257
M70Q16L	2012427	63	1453	1283	338	514	137	170	108	14-22	—	—	533
M70Q16M	2012431	63	1453	1283	449	514	137	170	108	14-22	—	—	608
M70Q16H	2012435	63	1453	1283	514	514	137	170	108	14-22	—	—	676
M70Q18L	2012439	63	1497	1327	338	578	137	170	108	16-25	—	—	590
M70Q18M	2012443	63	1497	1327	443	578	137	170	108	16-25	—	—	699
M70Q18H	2012447	63	1497	1327	494	578	137	170	108	16-25	—	—	766
M70Q20L	2012451	63	1548	1378	338	629	137	170	108	19-28	—	—	651
M70Q20M	2012455	63	1548	1378	452	629	137	170	108	19-28	—	—	786
M70Q20H	2012459	63	1548	1378	554	629	137	170	108	19-28	—	—	945
M70Q24L	2012463	63	1637	1467	338	730	137	170	108	22-32	—	—	779
M70Q24M	2012467	63	1637	1467	535	730	137	170	108	22-32	—	—	1082
M70Q24H	2012471	63	1637	1467	637	730	137	170	108	22-32	—	—	1300
M70QN16L	2012475	63	1640	1283	464	514	137	170	108	14-22	38.1	42.2	608
M70QN16M	2012479	63	1640	1283	575	514	137	170	108	14-22	38.1	42.2	683
M70QN16H	2012483	63	1640	1283	638	514	137	170	108	14-22	38.1	42.2	751
M70QN18L	2012487	63	1608	1327	464	578	137	170	108	16-25	38.1	42.2	760
M70QN18M	2012491	63	1608	1327	568	578	137	170	108	16-25	38.1	42.2	860
M70QN18H	2012495	63	1608	1327	619	578	137	170	108	16-25	38.1	42.2	949
M70QN20L	2012499	63	1675	1378	464	629	137	170	108	19-28	38.1	52.5	857
M70QN20M	2012503	63	1675	1378	578	629	137	170	108	19-28	38.1	52.5	991
M70QN20H	2012507	63	1675	1378	679	629	137	170	108	19-28	38.1	52.5	1151
M70QN24L	2012511	63	1764	1467	464	730	137	170	108	22-32	38.1	52.5	1012
M70QN24M	2012515	63	1764	1467	660	730	137	170	108	22-32	38.1	52.5	1315
M70QN24H	2012519	63	1764	1467	762	730	137	170	108	22-32	38.1	52.5	1533
M70SX16L	2012523	63	1564	1283	518	514	137	170	108	14-22	38.1	42.2	700
M70SX16M	2012527	63	1564	1283	629	514	137	170	108	14-22	38.1	42.2	776
M70SX16H	2012531	63	1564	1283	693	514	137	170	108	14-22	38.1	42.2	844
M70SX18L	2012535	63	1624	1327	518	578	137	170	108	16-25	38.1	52.5	869
M70SX18M	2012539	63	1624	1327	623	578	137	170	108	16-25	38.1	52.5	968
M70SX18H	2012543	63	1624	1327	674	578	137	170	108	16-25	38.1	52.5	1036
M70SX20L	2012547	63	1675	1378	518	629	137	170	108	19-28	38.1	52.5	914
M70SX20M	2012551	63	1675	1378	633	629	137	170	108	19-28	38.1	52.5	1048
M70SX20H	2012555	63	1675	1378	734	629	137	170	108	19-28	38.1	52.5	1208
<b>68 TONNES</b>													
M75D24L	2012559	68	1637	1467	282	730	137	170	108	22-32	—	—	690
M75D24M	2012563	68	1637	1467	479	730	137	170	108	22-32	—	—	993
M75D24H	2012567	68	1637	1467	580	730	137	170	108	22-32	—	—	1211
M75T20L	2012571	68	1548	1378	282	629	137	170	108	19-28	—	—	641
M75T20M	2012575	68	1548	1378	397	629	137	170	108	19-28	—	—	776
M75T20H	2012579	68	1548	1378	498	629	137	170	108	19-28	—	—	935
M75T24L	2012583	68	1637	1467	282	730	137	170	108	22-32	—	—	737
M75T24M	2012587	68	1637	1467	480	730	137	170	108	22-32	—	—	1039
M75T24H	2012591	68	1637	1467	581	730	137	170	108	22-32	—	—	1257
M75Q16L	2012595	68	1453	1283	338	514	137	170	108	14-22	—	—	533
M75Q16M	2012600	68	1453	1283	449	514	137	170	108	14-22	—	—	608
M75Q16H	2012604	68	1453	1283	513	514	137	170	108	14-22	—	—	676
M75Q18L	2012595	68	1497	1327	338	578	137	170	108	16-25	—	—	590
M75Q18M	2012599	68	1497	1327	443	578	137	170	108	16-25	—	—	699
M75Q18H	2012603	68	1497	1327	494	578	137	170	108	16-25	—	—	766
M75Q20L	2012607	68	1548	1378	338	629	137	170	108	19-28	—	—	651
M75Q20M	2012611	68	1548	1378	452	629	137	170	108	19-28	—	—	786
M75Q20H	2012615	68	1548	1378	554	629	137	170	108	19-28	—	—	945
M75Q24L	2012619	68	1637	1467	338	730	137	170	108	22-32	—	—	779

# McKissick® 380 Series Crane Blocks



## 380 Series Crane Blocks

Model No.	Inquiry Stock No.	Working Load Limit (t) †	A Overall Length (mm)	B Net Length (mm)	E Thickness (mm)	F Width (mm)	H Throat Opening with Flapper (mm)	J Hook Thickness (mm)	K Hook Width (mm)	Standard Wireline Sizes (mm)*	Dead End ‡		Weight Each (kg)
											T Thickness (mm)	U Pin Hole (mm)	
M75Q24M	2012623	68	1637	1467	535	730	137	170	108	22-32	—	—	1082
M75Q24H	2012627	68	1637	1467	637	730	137	170	108	22-32	—	—	1300
M75QN16L	2012631	68	1564	1283	464	514	137	170	108	14-22	38.1	42.2	608
M75QN16M	2012635	68	1564	1283	575	514	137	170	108	14-22	38.1	42.2	644
M75QN16H	2012639	68	1564	1283	638	514	137	170	108	14-22	38.1	42.2	751
M75QN18L	2012632	68	1608	1327	464	565	137	170	108	16-25	38.1	42.2	760
M75QN18M	2012636	68	1608	1327	568	565	137	170	108	16-25	38.1	42.2	860
M75QN18H	2012640	68	1608	1327	619	578	137	170	108	16-25	38.1	42.2	927
M75QN20L	2012643	68	1675	1378	464	629	137	170	108	19-28	38.1	52.5	857
M75QN20M	2012647	68	1675	1378	578	629	137	170	108	19-28	38.1	52.5	991
M75QN20H	2012651	68	1675	1378	679	629	137	170	108	19-28	38.1	52.5	1151
M75QN24L	2012655	68	1637	1467	464	730	137	170	108	22-32	38.1	52.5	1012
M75QN24M	2012659	68	1637	1467	660	730	137	170	108	22-32	38.1	52.5	1315
M75QN24H	2012663	68	1637	1467	762	730	137	170	108	22-32	38.1	52.5	1533
M75SX16L	2012668	68	1564	1283	518	514	137	170	108	14-22	38.1	52.5	700
M75SX16M	2012672	68	1564	1283	629	514	137	170	108	14-22	38.1	52.5	776
M75SX16H	2012676	68	1564	1283	693	514	137	170	108	14-22	38.1	52.5	844
M75SX18L	2012667	68	1624	1327	518	578	137	170	108	16-25	38.1	52.5	869
M75SX18M	2012671	68	1624	1327	623	578	137	170	108	16-25	38.1	52.5	968
M75SX18H	2012675	68	1624	1327	674	578	137	170	108	16-25	38.1	52.5	1036
M75SX20L	2012679	68	1675	1378	518	629	137	170	108	19-28	38.1	52.5	914
M75SX20M	2012683	68	1675	1378	633	629	137	170	108	19-28	38.1	52.5	1048
M75SX20H	2012687	68	1675	1378	734	629	137	170	108	19-28	38.1	52.5	1208
<b>72 TONNES</b>													
M80D24L	2012691	72	1637	1467	282	730	137	170	108	22-32	—	—	690
M80D24M	2012695	72	1637	1467	479	730	137	170	108	22-32	—	—	993
M80D24H	2012699	72	1637	1467	580	730	137	170	108	22-32	—	—	1211
M80T20L	2012703	72	1548	1378	282	629	137	170	108	19-28	—	—	641
M80T20M	2012707	72	1548	1378	397	629	137	170	108	19-28	—	—	776
M80T20H	2012711	72	1548	1378	498	629	137	170	108	19-28	—	—	935
M80T24L	2012715	72	1637	1467	282	730	137	170	108	22-32	—	—	737
M80T24M	2012719	72	1637	1467	480	730	137	170	108	22-32	—	—	1040
M80T24H	2012723	72	1637	1467	581	730	137	170	108	22-32	—	—	1257
M80Q16L	2012727	72	1453	1283	338	514	137	170	108	14-22	—	—	533
M80Q16M	2012731	72	1453	1283	449	514	137	170	108	14-22	—	—	608
M80Q16H	2012735	72	1453	1283	513	514	137	170	108	14-22	—	—	676
M80Q18L	2012739	72	1497	1327	338	578	137	170	108	16-25	—	—	590
M80Q18M	2012743	72	1497	1327	443	578	137	170	108	16-25	—	—	699
M80Q18H	2012747	72	1497	1327	494	578	137	170	108	16-25	—	—	766
M80Q20L	2012751	72	1548	1378	338	629	137	170	108	19-28	—	—	651
M80Q20M	2012755	72	1548	1378	452	629	137	170	108	19-28	—	—	786
M80Q20H	2012759	72	1548	1378	554	629	137	170	108	19-28	—	—	945
M80Q24L	2012763	72	1637	1467	338	730	137	170	108	22-32	—	—	779
M80Q24M	2012767	72	1637	1467	535	730	137	170	108	22-32	—	—	1082
M80Q24H	2012771	72	1637	1467	637	730	137	170	108	22-32	—	—	1300
M80QN16L	2012775	72	1564	1283	464	514	137	170	108	14-22	38.1	42.2	608
M80QN16M	2012779	72	1564	1283	575	514	137	170	108	14-22	38.1	42.2	683
M80QN16H	2012783	72	1564	1283	638	514	137	170	108	14-22	38.1	42.2	751
M80QN18L	2012787	72	1608	1327	464	578	137	170	108	16-25	38.1	42.2	760
M80QN18M	2012791	72	1608	1327	568	578	137	170	108	16-25	38.1	42.2	860
M80QN18H	2012795	72	1608	1327	619	578	137	170	108	16-25	38.1	42.2	927
M80QN20L	2012799	72	1675	1378	464	629	137	170	108	19-28	38.1	52.5	857
M80QN20M	2012803	72	1675	1378	578	629	137	170	108	19-28	38.1	52.5	991
M80QN20H	2012807	72	1675	1378	679	629	137	170	108	19-28	38.1	52.5	1151
M80QN24L	2012811	72	1764	1467	464	730	137	170	108	22-32	38.1	52.5	1012
M80QN24M	2012815	72	1764	1467	660	730	137	170	108	22-32	38.1	52.5	1315
M80QN24H	2012819	72	1764	1467	762	730	137	170	108	22-32	38.1	52.5	1533
M80SX16L	2012823	72	1564	1283	518	514	137	170	108	14-22	38.1	52.5	700
M80SX16M	2012827	72	1564	1283	629	514	137	170	108	14-22	38.1	52.5	776
M80SX16H	2012831	72	1564	1283	693	514	137	170	108	14-22	38.1	52.5	844
M80SX18L	2012835	72	1624	1327	518	578	137	170	108	16-25	38.1	52.5	869
M80SX18M	2012839	72	1624	1327	623	578	137	170	108	16-25	38.1	52.5	968
M80SX18H	2012843	72	1624	1327	674	578	137	170	108	16-25	38.1	52.5	1036
M80SX20L	2012847	72	1675	1378	518	629	137	170	108	19-28	38.1	52.5	914
M80SX20M	2012851	72	1675	1378	633	629	137	170	108	19-28	38.1	52.5	1048
M80SX20H	2012855	72	1675	1378	734	629	137	170	108	19-28	38.1	52.5	1208
<b>81 TONNES</b>													
M90T24L	2012859	81	1740	1522	296	730	114	218	140	22-32	—	—	876
M90T24M	2012863	81	1740	1522	493	730	114	218	140	22-32	—	—	1179
M90T24H	2012867	81	1740	1522	595	730	114	218	140	22-32	—	—	1397

**McKISSICK® BLOCKS**



## 380 Series Crane Blocks

Model No.	Inquiry Stock No.	Working Load Limit (t) †	A Overall Length (mm)	B Net Length (mm)	E Thickness (mm)	F Width (mm)	H Throat Opening with Flapper (mm)	J Hook Thickness (mm)	K Hook Width (mm)	Standard Wireline Sizes (mm)*	Dead End ‡		Weight Each (kg)
											T Thickness (mm)	U Pin Hole (mm)	
M90Q20L	2012871	81	1626	1407	344	629	114	218	140	19-28	—	—	807
M90Q20M	2012875	81	1626	1407	459	629	114	218	140	19-28	—	—	941
M90Q20H	2012879	81	1626	1407	560	629	114	218	140	19-28	—	—	1101
M90Q24L	2012883	81	1740	1522	351	730	114	218	140	22-32	—	—	938
M90Q24M	2012887	81	1740	1522	548	730	114	218	140	22-32	—	—	1225
M90Q24H	2012891	81	1740	1522	649	730	114	218	140	22-32	—	—	1442
M90QN18L	2012904	81	1702	1369	464	578	114	218	140	16-25	38.1	58	875
M90QN18M	2012908	81	1702	1369	568	578	114	218	140	16-25	38.1	58	984
M90QN18H	2012912	81	1702	1369	619	578	114	218	140	16-25	38.1	58	1051
M90QN20L	2012895	81	1753	1407	464	629	114	218	140	19-28	38.1	58	927
M90QN20M	2012899	81	1753	1407	578	629	114	218	140	19-28	38.1	58	1061
M90QN20H	2012903	81	1753	1407	679	629	114	218	140	19-28	38.1	58	1221
M90QN24L	2012907	81	1854	1509	464	730	114	218	140	22-32	38.1	58	1124
M90QN24M	2012911	81	1854	1509	660	730	114	218	140	22-32	38.1	58	1427
M90QN24H	2012915	81	1854	1509	762	730	114	218	140	22-32	38.1	58	1644
M90SX18L	2012919	81	1702	1357	518	578	114	218	140	16-25	38.1	52.5	943
M90SX18M	2012923	81	1702	1357	623	578	114	218	140	16-25	38.1	52.5	1043
M90SX18H	2012927	81	1702	1357	674	578	114	218	140	16-25	38.1	52.5	1110
M90SX20L	2012931	81	1753	1407	518	629	114	218	140	19-28	38.1	52.5	982
M90SX20M	2012935	81	1753	1407	633	629	114	218	140	19-28	38.1	52.5	1117
M90SX20H	2012939	81	1753	1407	734	629	114	218	140	19-28	38.1	52.5	1277
M90SX24L	2012943	81	1854	1509	518	730	114	218	140	22-32	38.1	52.5	1186
M90SX24M	2012947	81	1854	1509	715	730	114	218	140	22-32	38.1	52.5	1473
M90SX24H	2012952	81	1854	1509	817	730	114	218	140	22-32	38.1	52.5	1692
<b>90 TONNES</b>													
M100T24L	2012860	90	1740	1522	296	730	114	218	140	22-32	—	—	876
M100T24M	2012864	90	1740	1522	493	730	114	218	140	22-32	—	—	1179
M100T24H	2012868	90	1740	1522	595	730	114	218	140	22-32	—	—	1397
M100Q20L	2012967	90	1626	1407	344	629	114	218	140	19-28	—	—	807
M100Q20M	2012971	90	1626	1407	459	629	114	218	140	19-28	—	—	941
M100Q20H	2012975	90	1626	1407	560	629	114	218	140	19-28	—	—	1101
M100Q24L	2012979	90	1740	1522	351	730	114	218	140	22-32	—	—	938
M100Q24M	2012983	90	1740	1522	548	730	114	218	140	22-32	—	—	1225
M100Q24H	2012987	90	1740	1522	649	730	114	218	140	22-32	—	—	1442
M100QN18L	2012991	90	1702	1369	464	578	114	218	140	16-25	38.1	58	875
M100QN18M	2012995	90	1702	1369	568	578	114	218	140	16-25	38.1	58	984
M100QN18H	2012999	90	1702	1369	619	578	114	218	140	16-25	38.1	58	1051
M100QN20L	2013003	90	1753	1407	464	629	114	218	140	19-28	38.1	58	927
M100QN20M	2013007	90	1753	1407	578	629	114	218	140	19-28	38.1	58	1061
M100QN20H	2013011	90	1753	1407	679	629	114	218	140	19-28	38.1	58	1221
M100QN24L	2013015	90	1854	1509	464	730	114	218	140	22-32	38.1	58	1124
M100QN24M	2013019	90	1854	1509	660	730	114	218	140	22-32	38.1	58	1427
M100QN24H	2013023	90	1854	1509	762	730	114	218	140	22-32	38.1	58	1644
M100SX18L	2013027	90	1702	1357	518	578	114	218	140	16-25	38.1	52.5	943
M100SX18M	2013031	90	1702	1357	623	578	114	218	140	16-25	38.1	52.5	1043
M100SX18H	2013035	90	1702	1357	674	578	114	218	140	16-25	38.1	52.5	1110
M100SX20L	2013039	90	1753	1407	518	629	114	218	140	19-28	38.1	52.5	982
M100SX20M	2013043	90	1753	1407	633	629	114	218	140	19-28	38.1	52.5	1117
M100SX20H	2013047	90	1753	1407	734	629	114	218	140	19-28	38.1	52.5	1277
M100SX24L	2013051	90	1854	1509	518	730	114	218	140	22-32	38.1	52.5	1186
M100SX24M	2013055	90	1854	1509	715	730	114	218	140	22-32	38.1	52.5	1473
M100SX24H	2013059	90	1854	1509	817	730	114	218	140	22-32	38.1	52.5	1692
<b>104 TONNES</b>													
M115Q24L	2013075	104	1829	1597	418	730	114	232	152	22-32	—	—	1249
M115Q24M	2013079	104	1829	1597	614	730	114	232	152	22-32	—	—	1535
M115Q24H	2013083	104	1829	1597	716	730	114	232	152	22-32	—	—	1753
M115QN24L	2013087	104	1962	1597	514	730	114	232	152	22-32	44.5	64.5	1506
M115QN24M	2013091	104	1962	1597	711	730	114	232	152	22-32	44.5	64.5	1792
M115QN24H	2013095	104	1962	1597	813	730	114	232	152	22-32	44.5	64.5	2009
M115SX18L	2013099	104	1810	1445	559	578	114	232	152	16-25	44.5	64.5	1200
M115SX18M	2013103	104	1810	1445	663	578	114	232	152	16-25	44.5	64.5	1309
M115SX18H	2013107	104	1810	1445	714	578	114	232	152	16-25	44.5	64.5	1376
M115SX20L	2013111	104	1861	1496	559	629	114	232	152	19-28	44.5	64.5	1292
M115SX20M	2013115	104	1861	1496	673	629	114	232	152	19-28	44.5	64.5	1427
M115SX20H	2013119	104	1861	1496	775	629	114	232	152	19-28	44.5	64.5	1586
M115SX24L	2013123	104	1962	1597	560	730	114	232	152	22-32	44.5	64.5	1508
M115SX24M	2013127	104	1962	1597	756	730	114	232	152	22-32	44.5	64.5	1795
M115SX24H	2013131	104	1962	1597	858	730	114	232	152	22-32	44.5	64.5	2013
<b>113 TONNES</b>													
M125Q24L	2013135	113	1829	1597	418	730	114	232	152	22-32	—	—	1249

# McKissick® 380 Series Crane Blocks



## 380 Series Crane Blocks

Model No.	Inquiry Stock No.	Working Load Limit (t) †	A Overall Length (mm)	B Net Length (mm)	E Thickness (mm)	F Width (mm)	H Throat Opening with Flapper (mm)	J Hook Thickness (mm)	K Hook Width (mm)	Standard Wireline Sizes (mm)*	Dead End ‡		Weight Each (kg)
											T Thickness (mm)	U Pin Hole (mm)	
M125Q24M	2013139	113	1829	1597	614	730	114	232	152	22-32	—	—	1535
M125Q24H	2013143	113	1829	1597	716	730	114	232	152	22-32	—	—	1753
M125QN24L	2013147	113	1962	1597	514	730	114	232	152	22-32	44.5	64.5	1506
M125QN24M	2013151	113	1962	1597	711	730	114	232	152	22-32	44.5	64.5	1792
M125QN24H	2013155	113	1962	1597	813	730	114	232	152	22-32	44.5	64.5	2009
M125SX18L	2013159	113	1810	1445	559	578	114	232	152	16-25	44.5	64.5	1200
M125SX18M	2013163	113	1810	1445	663	578	114	232	152	16-25	44.5	64.5	1309
M125SX18H	2013167	113	1810	1445	714	578	114	232	152	16-25	44.5	64.5	1376
M125SX20L	2013171	113	1861	1496	559	629	114	232	152	19-28	44.5	64.5	1292
M125SX20M	2013175	113	1861	1496	673	629	114	232	152	19-28	44.5	64.5	1427
M125SX20H	2013179	113	1861	1496	775	629	114	232	152	19-28	44.5	64.5	1586
M125SX24L	2013183	113	1962	1597	560	730	114	232	152	22-32	44.5	64.5	1508
M125SX24M	2013187	113	1962	1597	756	730	114	232	152	22-32	44.5	64.5	1795
M125SX24H	2013188	113	1962	1597	858	730	114	232	152	22-32	44.5	64.5	2013
<b>117 TONNES</b>													
M130Q24L	2013192	117	1829	1597	418	730	114	232	152	22-32	—	—	1249
M130Q24M	2013196	117	1829	1597	614	730	114	232	152	22-32	—	—	1535
M130Q24H	2013200	117	1829	1597	716	730	114	232	152	22-32	—	—	1753
M130QN24L	2013191	117	1962	1597	514	730	114	232	152	22-32	44.5	64.5	1506
M130QN24M	2013195	117	1962	1597	711	730	114	232	152	22-32	44.5	64.5	1792
M130QN24H	2013199	117	1962	1597	813	730	114	232	152	22-32	44.5	64.5	2009
M130SX18L	2013203	117	1810	1445	559	578	114	232	152	16-25	44.5	64.5	1200
M130SX18M	2013207	117	1810	1445	663	578	114	232	152	16-25	44.5	64.5	1309
M130SX18H	2013211	117	1810	1445	714	578	114	232	152	16-25	44.5	64.5	1376
M130SX20L	2013218	117	1861	1496	559	629	114	232	152	19-28	44.5	64.5	1292
M130SX20M	2013219	117	1861	1496	673	629	114	232	152	19-28	44.5	64.5	1427
M130SX20H	2013223	117	1861	1496	775	629	114	232	152	19-28	44.5	64.5	1586
M130SX24L	2013227	117	1962	1597	560	730	114	232	152	22-32	44.5	64.5	1508
M130SX24M	2013231	117	1962	1597	756	730	114	232	152	22-32	44.5	64.5	1795
M130SX24H	2013235	117	1962	1597	858	730	114	232	152	22-32	44.5	64.5	2013
<b>126 TONNES</b>													
M140Q24L	2013252	126	1829	1597	418	730	114	232	152	22-32	—	—	1249
M140Q24M	2013256	126	1829	1597	614	730	114	232	152	22-32	—	—	1535
M140Q24H	2013260	126	1829	1597	716	730	114	232	152	22-32	—	—	1753
M140QN24L	2013251	126	1962	1597	514	730	114	232	152	22-32	44.5	64.5	1506
M140QN24M	2013255	126	1962	1597	711	730	114	232	152	22-32	44.5	64.5	1792
M140QN24H	2013259	126	1962	1597	813	730	114	232	152	22-32	44.5	64.5	2009
M140SX18L	2013263	126	1810	1445	559	578	114	232	152	16-25	44.5	64.5	1200
M140SX18M	2013267	126	1810	1445	663	578	114	232	152	16-25	44.5	64.5	1309
M140SX18H	2013271	126	1810	1445	714	578	114	232	152	16-25	44.5	64.5	1376
M140SX20L	2013275	126	1861	1496	559	629	114	232	152	19-28	44.5	64.5	1292
M140SX20M	2013279	126	1861	1496	673	629	114	232	152	19-28	44.5	64.5	1427
M140SX20H	2013283	126	1861	1496	775	629	114	232	152	19-28	44.5	64.5	1586
M140SX24L	2013287	126	1962	1597	560	730	114	232	152	22-32	44.5	64.5	1508
M140SX24M	2013291	126	1962	1597	756	730	114	232	152	22-32	44.5	64.5	1795
M140SX24H	2013295	126	1962	1597	858	730	114	232	152	22-32	44.5	64.5	2013
<b>135 TONNES</b>													
M150Q24L	2013299	135	1829	1597	418	730	114	232	152	22-32	—	—	1249
M150Q24M	2013303	135	1829	1597	614	730	114	232	152	22-32	—	—	1535
M150Q24H	2013307	135	1829	1597	716	730	114	232	152	22-32	—	—	1753
M150QN24L	2013311	135	1962	1597	559	730	114	232	152	22-32	44.5	64.5	1658
M150QN24M	2013315	135	1962	1597	756	730	114	232	152	22-32	44.5	64.5	1945
M150QN24H	2013319	135	1962	1597	857	730	114	232	152	22-32	44.5	64.5	2164
M150SX20L	2013323	135	1861	1496	559	629	114	232	152	19-28	44.5	64.5	1292
M150SX20M	2013327	135	1861	1496	673	629	114	232	152	19-28	44.5	64.5	1427
M150SX20H	2013331	135	1861	1496	775	629	114	232	152	19-28	44.5	64.5	1586
M150SX24L	2013335	135	1962	1597	560	730	114	232	152	22-32	44.5	64.5	1508
M150SX24M	2013339	135	1962	1597	756	730	114	232	152	22-32	44.5	64.5	1795
M150SX24H	2013343	135	1962	1597	858	730	114	232	152	22-32	44.5	64.5	2013
<b>149 TONNES</b>													
M165Q24L	2013347	149	1829	1597	418	730	114	232	152	22-32	—	—	1249
M165Q24M	2013351	149	1829	1597	614	730	114	232	152	22-32	—	—	1535
M165Q24H	2013355	149	1829	1597	716	730	114	232	152	22-32	—	—	1753
M165QN24L	2013359	149	1962	1597	559	730	114	232	152	22-32	44.5	64.5	1658
M165QN24M	2013363	149	1962	1597	756	730	114	232	152	22-32	44.5	64.5	1945
M165QN24H	2013367	149	1962	1597	857	730	114	232	152	22-32	44.5	64.5	2164
M165SX20L	2013371	149	1861	1496	559	629	114	232	152	19-28	44.5	64.5	1292
M165SX20M	2013375	149	1861	1496	673	629	114	232	152	19-28	44.5	64.5	1427
M165SX20H	2013379	149	1861	1496	775	883	114	232	152	19-28	44.5	64.5	1586
M165SX24L	2013383	149	1962	1597	560	730	114	232	152	22-32	44.5	64.5	1508

**McKISSICK® BLOCKS**

## 380 Series Crane Blocks

Model No.	Inquiry Stock No.	Working Load Limit (t) †	A Overall Length (mm)	B Net Length (mm)	E Thickness (mm)	F Width (mm)	H Throat Opening with Flapper (mm)	J Hook Thickness (mm)	K Hook Width (mm)	Standard Wireline Sizes (mm)*	Dead End ‡		Weight Each (kg)
											T Thickness (mm)	U Pin Hole (mm)	
M165SX24M	2013387	149	1962	1597	756	730	114	232	152	22-32	44.5	64.5	1795
M165SX24H	2013391	149	1962	1597	858	730	114	232	152	22-32	44.5	64.5	2013
<b>180 TONNES</b>													
M200QN24L	2013395	180	2102	1721	610	730	127	248	178	22-32	44.5	64.5	2087
M200QN24M	2013399	180	2102	1721	806	730	127	248	178	22-32	44.5	64.5	2439
M200QN24H	2013403	180	2102	1721	908	730	127	248	178	22-32	44.5	64.5	2649
M200QN30L	2013396	180	2254	1873	610	883	127	248	178	25-35	44.5	64.5	2378
M200QN30M	2013400	180	2254	1873	673	883	127	248	178	25-35	44.5	64.5	2786
M200QN30H	2013404	180	2254	1873	711	883	127	248	178	25-35	44.5	64.5	3049
M200SX24L	2013407	180	2102	1721	610	730	127	248	178	22-32	44.5	64.5	1985
M200SX24M	2013411	180	2102	1721	806	730	127	248	178	22-32	44.5	64.5	2275
M200SX24H	2013415	180	2102	1721	908	730	127	248	178	22-32	44.5	64.5	2491
M200SX30L	2013419	180	2254	1873	610	883	127	248	178	25-35	44.5	64.5	2540
M200SX30M	2013423	180	2254	1873	673	883	127	248	178	25-35	44.5	64.5	3207
M200SX30H	2013427	180	2254	1873	711	883	127	248	178	25-35	44.5	64.5	3272
<b>204 TONNES</b>													
M225QN24L	2013420	204	2102	1721	610	730	159	270	184	22-32	44.5	64.5	2119
M225QN24M	2013424	204	2102	1721	806	730	159	270	184	22-32	44.5	64.5	2439
M225QN24H	2013428	204	2102	1721	908	730	159	270	184	22-32	44.5	64.5	2649
M225QN30L	2013421	204	2254	1873	610	883	159	270	184	25-35	44.5	64.5	2378
M225QN30M	2013425	204	2254	1873	673	883	159	270	184	25-35	44.5	64.5	2786
M225QN30H	2013429	204	2254	1873	711	883	159	270	184	25-35	44.5	64.5	3049
M225SX24L	2013422	204	2102	1721	610	730	159	270	184	22-32	44.5	64.5	1985
M225SX24M	2013426	204	2102	1721	806	730	159	270	184	22-32	44.5	64.5	2272
M225SX24H	2013430	204	2102	1721	908	730	159	270	184	22-32	44.5	64.5	2491
M225SX30L	2013432	204	2254	1873	610	883	159	270	184	25-35	44.5	64.5	2601
M225SX30M	2013436	204	2254	1873	673	883	159	270	184	25-35	44.5	64.5	3009
M225SX30H	2013440	204	2254	1873	711	883	159	270	184	25-35	44.5	64.5	3272
<b>226 TONNES</b>													
M250SX30L	2013431	226	2369	1965	724	927	159	270	184	25-35	57	64.5	3299
M250SX30M	2013435	226	2369	1965	826	927	159	270	184	25-35	57	64.5	3699
M250SX30H	2013439	226	2369	1965	876	927	159	270	184	25-35	57	64.5	3957
M250SV24L	2013443	226	2216	1813	914	730	159	270	184	22-32	57	64.5	2930
M250SV24M	2013447	226	2216	1813	1111	730	159	270	184	22-32	57	64.5	3249
M250SV24H	2013451	226	2216	1813	1213	730	159	270	184	22-32	57	64.5	3460
<b>249 TONNES</b>													
M275SX30L	2013456	249	2369	1965	724	927	159	270	184	25-35	57	64.5	3299
M275SX30M	2013460	249	2369	1965	826	927	159	270	184	25-35	57	64.5	3699
M275SX30H	2013464	249	2369	1965	876	927	159	270	184	25-35	57	64.5	3957
M275SV24L	2013457	249	2216	1813	914	730	159	270	184	22-32	57	64.5	2930
M275SV24M	2013461	249	2216	1813	1111	730	159	270	184	22-32	57	64.5	3249
M275SV24H	2013465	249	2216	1813	1213	730	159	270	184	22-32	57	64.5	3460
<b>272 TONNES</b>													
M300SX30L	2013479	272	2369	1965	724	927	159	270	184	25-35	57	64.5	3299
M300SX30M	2013483	272	2369	1965	826	927	159	270	184	25-35	57	64.5	3699
M300SX30H	2013487	272	2369	1965	876	927	159	270	184	25-35	57	64.5	3957
M300SV24L	2013491	272	2216	1813	914	730	159	270	184	22-32	57	64.5	2930
M300SV24M	2013495	272	2216	1813	1111	730	159	270	184	22-32	57	64.5	3249
M300SV24H	2013499	272	2216	1813	1213	730	159	270	184	22-32	57	64.5	3460
M300OCT30L	2013527	272	2369	1965	914	927	159	270	184	25-35	57	64.5	4602
M300OCT30M	2013531	272	2369	1965	965	927	159	270	184	25-35	57	64.5	4938
M300OCT30H	2013535	272	2369	1965	991	927	159	270	184	25-35	57	64.5	5258

\* Additional Wireline sizes available upon request.

† Ultimate Load is 4 times the Working Load Limit unless otherwise noted.

‡ Dead End dimensions for 2, 3, & 4 sheave blocks are shown on page 310.





## 380 SERIES EASY REEVE® HOOK BLOCKS

- Wide range of products available.
  - Capacity: 5 to 80 Tons - Larger Models Available.
  - Sheave Sizes: 10" to 20".
  - Wireline Sizes: 7/16" to 1-1/4".
- All single point shank hooks are genuine Crosby®, forged alloy steel, Quenched and Tempered, and have the patented **QUIC-CHECK®** markings (Duplex hooks are available on most sizes).
- Design factor of 4 to 1 (unless otherwise noted).
- All Easy Reeve® Blocks are furnished standard with Roller Bearings.
- Reeving Guides Standard – All Models.
- Blocks thru 25 Tons use 319N hooks with S-4320 latches.
- Heavy Duty Positive Locking (PL) Latch – Models: 30 Tons and larger.
- Sheave lubrication through center pin - separate lube channel to each bearing.
- Sheaves fully protected by side plates.
- Dual action hook (swings and rotates).
- Repair parts available through worldwide distribution network.
- All Easy Reeve® blocks 406mm and larger are furnished with McKissick® Roll-Forged sheaves with flame hardened grooves.
- Manufactured by an ISO 9001 and API Q1 certified facility.
- "Look for the Orange Hook . . . the mark of genuine McKissick® quality."



### OPTIONS AVAILABLE

- Duplex Hooks
- Swivel Tee and Shackle Assemblies
- Sheave Shrouds
- Anti-Rotation Hook-Locking Device
- Plate Steel Cheek Weights
- Third party testing with Certification available upon request.

**Center "Dead End"** to promote better block travel under various reeving configurations.

The patented McKissick Split-Nut® is the standard retention system for standard crane blocks up to 100 Tons.

For custom orders contact our Block Hotline at: (800) 727-1555, or reference the special request form on page 454.

**Sheave Guards** that open to allow block reeving without removing the rope end fitting.



**Flat Bottom** side plate for self standing during reeving process.



**380 Series Easy Reeve® Hook Block**

**Forged Crosby® alloy steel hooks** with patented **QUIC-CHECK®** markings and Heavy Duty positive locking hook latch.

The patented McKissick Split-Nut® is the standard retention system for standard crane blocks up to 90 tonnes.

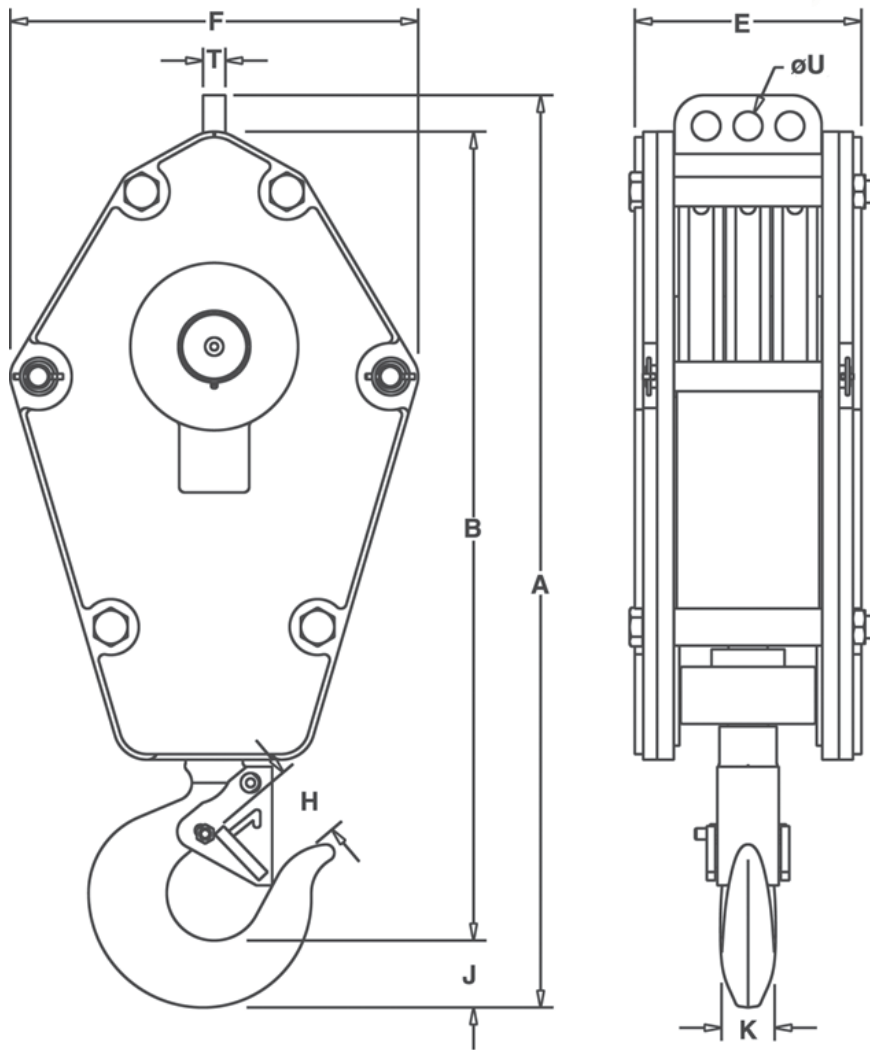

**Dead End Block  
Double, Triple & Quad Sheave Blocks**

Wireline Size (mm)	Dimensions (mm)		Recommended Wedge Socket	
	T Thickness	U Hole Diameter	McKissick® US-422 / US-422T Utility Socket	
			Stock No.	Size
11	25.4	32.5	1044309+	US4 11
13	25.4	32.5	1044318+	US4 13
14	25.4	32.5	1044336+	US5 14
16	25.4	32.5	1044345+	US5 16
19	31.8	42.2	1044363+	US6 19
22	31.8	42.2	1038580	US7 22
25	31.8	42.2	1044417+	US8 25
28	44.5	65.0	1044426+	US10 28
32	44.5	65.0	1044435+	US10 32

+ US-422T TERMINATOR™ Style.

# McKissick® Easy Reeve® Crane Blocks



## McKissick® Easy Reeve® Crane Blocks

- Specify Wireline size when ordering.
- Dead End Dimensions on page 326 of this catalog.
- All sizes are RFID EQUIPPED.

Model No.	Inquiry Stock No.	Working Load Limit (t)*	A Overall Length (mm)	B Net Length (mm)	E Block Thickness (mm)	F Block Width (mm)	H Throat Opening with Flapper (mm)	J Hook Thickness (mm)	K Hook Width (mm)	Standard Wire Line Sizes (mm)	Weight Each (kg)†
<b>4.5 Tonnes</b>											
E5S10L	2014001	4.5	909	789	174	368	48.5	66	49.3	11-16	107
E5S10M	2014003	4.5	909	789	225	368	48.5	66	49.3	11-16	155
E5S10H	2014004	4.5	909	789	263	368	48.5	66	49.3	11-16	192
<b>9 Tonnes</b>											
E10S10L	2014011	9	909	789	174	368	48.5	66	49.3	11-16	107
E10S10M	2014013	9	909	789	225	368	48.5	66	49.3	11-16	155
E10S10H	2014014	9	909	789	263	368	48.5	66	49.3	11-16	192
E10S14L	2014021	9	1001	881	174	464	48.5	66	49.3	13-19	125
E10S14M	2014023	9	1001	881	225	464	48.5	66	49.3	13-19	194
E10S14H	2014024	9	1001	881	263	464	48.5	66	49.3	13-19	246
E10S16L	2014031	9	1096	976	174	521	48.5	66	49.3	14-22	149
E10S16M	2014033	9	1096	976	225	521	48.5	66	49.3	14-22	239
E10S16H	2014034	9	1096	976	263	521	48.5	66	49.3	14-22	308
E10D10L	2014041	9	909	789	174	368	48.5	66	49.3	11-16	122
E10D10M	2014043	9	909	789	225	368	48.5	66	49.3	11-16	170
E10D10H	2014044	9	909	789	263	368	48.5	66	49.3	11-16	204
E10D12L	2014051	9	947	827	174	419	48.5	66	49.3	13-19	126
E10D12M	2014053	9	947	827	225	419	48.5	66	49.3	13-19	182
E10D12H	2014054	9	947	827	263	419	48.5	66	49.3	13-19	225
E10T10L	2014061	9	909	789	207	368	48.5	66	49.3	11-16	144
E10T10M	2014063	9	909	789	258	368	48.5	66	49.3	11-16	192
E10T10H	2014064	9	909	789	296	368	48.5	66	49.3	11-16	230
E10T12L	2014071	9	947	827	207	419	48.5	66	49.3	13-19	147
E10T12M	2014073	9	947	827	258	419	48.5	66	49.3	13-19	202
E10T12H	2014074	9	947	827	296	419	48.5	66	49.3	13-19	245
E10Q14L	2014081	9	1001	881	264	464	48.5	66	49.3	13-19	194
E10Q14M	2014083	9	1001	881	314	464	48.5	66	49.3	13-19	267
E10Q14H	2014084	9	1001	881	353	464	48.5	66	49.3	13-19	319
<b>13.5 Tonnes</b>											
E15S10L	2014091	13.5	909	789	174	368	48.5	66	49.3	11-16	107
E15S10M	2014093	13.5	909	789	225	368	48.5	66	49.3	11-16	155
E15S10H	2014094	13.5	909	789	263	368	48.5	66	49.3	11-16	192
E15S12L	2014101	13.5	947	827	174	419	48.5	66	49.3	13-19	114
E15S12M	2014103	13.5	947	827	225	419	48.5	66	49.3	13-19	170
E15S12H	2014104	13.5	947	827	263	419	48.5	66	49.3	13-19	213
E15S14L	2014111	13.5	1001	881	174	464	48.5	66	49.3	13-19	125
E15S14M	2014113	13.5	1001	881	225	464	48.5	66	49.3	13-19	194
E15S14H	2014114	13.5	1001	881	263	464	48.5	66	49.3	13-19	246
E15S16L	2014121	13.5	1096	976	174	521	48.5	66	49.3	14-22	149
E15S16M	2014123	13.5	1096	976	225	521	48.5	66	49.3	14-22	239
E15S16H	2014124	13.5	1096	976	263	521	48.5	66	49.3	14-22	308
E15D10L	2014131	13.5	909	789	174	368	48.5	66	49.3	11-16	122
E15D10M	2014133	13.5	909	789	225	368	48.5	66	49.3	11-16	170
E15D10H	2014134	13.5	909	789	263	368	48.5	66	49.3	11-16	207
E15D12L	2014141	13.5	947	827	174	419	48.5	66	49.3	13-19	126
E15D12M	2014143	13.5	947	827	225	419	48.5	66	49.3	13-19	182
E15D12H	2014144	13.5	947	827	263	419	48.5	66	49.3	13-19	225
E15T10L	2014151	13.5	909	789	207	368	48.5	66	49.3	11-16	144
E15T10M	2014153	13.5	909	789	258	368	48.5	66	49.3	11-16	192
E15T10H	2014154	13.5	909	789	296	368	48.5	66	49.3	11-16	230
E15T12L	2014161	13.5	947	827	207	419	48.5	66	49.3	13-19	147
E15T12M	2014163	13.5	947	827	258	419	48.5	66	49.3	13-19	202
E15T12H	2014164	13.5	947	827	296	419	48.5	66	49.3	13-19	245
E15Q14L	2014171	13.5	1001	881	264	464	48.5	66	49.3	13-19	194
E15Q14M	2014173	13.5	1001	881	314	464	48.5	66	49.3	13-19	267
E15Q14H	2014174	13.5	1001	881	353	464	48.5	66	49.3	13-19	319
<b>18 Tonnes</b>											
E20S10L	2014181	18	957	828	174	368	70	75.5	60.5	11-16	113
E20S10M	2014182	18	957	828	225	368	70	75.5	60.5	11-16	161
E20S10H	2014184	18	957	828	263	368	70	75.5	60.5	11-16	198
E20S14L	2014191	18	1049	920	174	464	70	75.5	60.5	13-19	133



# McKissick® Easy Reeve® Crane Blocks

## McKissick® Easy Reeve® Crane Blocks

Model No.	Inquiry Stock No.	Working Load Limit (t)*	A Overall Length (mm)	B Net Length (mm)	E Block Thickness (mm)	F Block Width (mm)	H Throat Opening with Flapper (mm)	J Hook Thickness (mm)	K Hook Width (mm)	Standard Wire Line Sizes (mm)	Weight Each (kg)†
E20S14M	2014193	18	1049	920	225	464	70	75.5	60.5	13-19	201
E20S14H	2014194	18	1049	920	263	464	70	75.5	60.5	13-19	254
E20S18L	2014201	18	1195	1066	174	565	70	75.5	60.5	16-26	177
E20S18M	2014203	18	1195	1066	231	565	70	75.5	60.5	16-26	297
E20S18H	2014204	18	1195	1066	269	565	70	75.5	60.5	16-26	378
E20D12L	2014211	18	995	866	174	419	70	75.5	60.5	13-19	132
E20D12M	2014213	18	995	866	225	419	70	75.5	60.5	13-19	188
E20D12H	2014214	18	995	866	263	419	70	75.5	60.5	13-19	231
E20D14L	2014221	18	1049	920	174	464	70	75.5	60.5	13-19	148
E20D14M	2014223	18	1049	920	225	464	70	75.5	60.5	13-19	216
E20D14H	2014224	18	1049	920	263	464	70	75.5	60.5	13-19	269
E20T12L	2014231	18	995	866	207	419	70	75.5	60.5	13-19	151
E20T12M	2014233	18	995	866	258	419	70	75.5	60.5	13-19	208
E20T12H	2014234	18	995	866	296	419	70	75.5	60.5	13-19	251
E20T14L	2014241	18	1049	920	207	464	70	75.5	60.5	13-19	171
E20T14M	2014243	18	1049	920	258	464	70	75.5	60.5	13-19	239
E20T14H	2014244	18	1049	920	296	464	70	75.5	60.5	13-19	292
E20Q12L	2014251	18	995	866	264	419	70	75.5	60.5	13-19	182
E20Q12M	2014253	18	995	866	314	419	70	75.5	60.5	13-19	238
E20Q12H	2014254	18	995	866	353	419	70	75.5	60.5	13-19	280
E20Q14L	2014261	18	1049	920	264	464	70	75.5	60.5	13-19	204
E20Q14M	2014263	18	1049	920	314	464	70	75.5	60.5	13-19	273
E20Q14H	2014264	18	1049	920	353	464	70	75.5	60.5	13-19	324
<b>23 Tonnes</b>											
E25S16L	2014271	23	1145	1015	174	521	70	75.5	60.5	14-22	155
E25S16M	2014273	23	1145	1015	225	521	70	75.5	60.5	14-22	244
E25S16H	2014274	23	1145	1015	263	521	70	75.5	60.5	14-22	313
E25S18L	2014281	23	1195	1066	174	565	70	75.5	60.5	16-26	177
E25S18M	2014283	23	1195	1066	231	565	70	75.5	60.5	16-26	296
E25S18H	2014284	23	1195	1066	269	565	70	75.5	60.5	16-26	378
E25D12L	2014291	23	995	866	174	419	70	75.5	60.5	13-19	132
E25D12M	2014293	23	995	866	225	419	70	75.5	60.5	13-19	188
E25D12H	2014294	23	995	866	263	419	70	75.5	60.5	13-19	231
E25D14L	2014301	23	1049	920	174	464	70	75.5	60.5	13-19	148
E25D14M	2014303	23	1049	920	225	464	70	75.5	60.5	13-19	216
E25D14H	2014304	23	1049	920	263	464	70	75.5	60.5	13-19	269
E25T12L	2014311	23	995	866	207	419	70	75.5	60.5	13-19	151
E25T12M	2014313	23	995	866	258	419	70	75.5	60.5	13-19	208
E25T12H	2014314	23	995	866	296	419	70	75.5	60.5	13-19	251
E25T14L	2014321	23	1049	920	207	464	70	75.5	60.5	13-19	167
E25T14M	2014323	23	1049	920	258	464	70	75.5	60.5	13-19	239
E25T14H	2014324	23	1049	920	296	464	70	75.5	60.5	13-19	292
E25Q12L	2014331	23	995	866	264	419	70	75.5	60.5	13-19	182
E25Q12M	2014333	23	995	866	314	419	70	75.5	60.5	13-19	238
E25Q12H	2014334	23	995	866	353	419	70	75.5	60.5	13-19	280
E25Q14L	2014341	23	1049	920	264	464	70	75.5	60.5	13-19	204
E25Q14M	2014343	23	1049	920	314	464	70	75.5	60.5	13-19	273
E25Q14H	2014344	23	1049	920	353	464	70	75.5	60.5	13-19	324
<b>27 Tonnes</b>											
E30S18L	2014351	27	1310	1173	174	565	82.5	92	76	16-26	207
E30S18M	2014353	27	1310	1173	231	565	82.5	92	76	16-26	326
E30S18H	2014354	27	1310	1173	269	565	82.5	92	76	16-26	407
E30S20L	2014356	27	1399	1173	174	622	82.5	92	76	19-28	253
E30S20M	2014358	27	1399	1173	225	622	82.5	92	76	19-28	393
E30S20H	2014359	27	1399	1173	263	622	82.5	92	76	19-28	500
E30D14L	2014361	27	1113	976	174	464	82.5	92	76	13-19	171
E30D14M	2014363	27	1113	976	225	464	82.5	92	76	13-19	239
E30D14H	2014364	27	1113	976	263	464	82.5	92	76	13-19	292
E30D18L	2014371	27	1310	1173	174	565	82.5	92	76	16-26	234
E30D18M	2014373	27	1310	1173	231	565	82.5	92	76	16-26	353
E30D18H	2014374	27	1310	1173	269	565	82.5	92	76	16-26	435
E30T14L	2014381	27	1164	1027	207	464	82.5	92	76	13-19	198
E30T14M	2014383	27	1164	1027	258	464	82.5	92	76	13-19	266
E30T14H	2014384	27	1164	1027	296	464	82.5	92	76	13-19	319
E30T16L	2014391	27	1259	1122	207	521	82.5	92	76	14-22	229
E30T16M	2014393	27	1259	1122	258	521	82.5	92	76	14-22	319
E30T16H	2014394	27	1259	1122	296	521	82.5	92	76	14-22	387
E30Q14L	2014401	27	1164	1027	264	464	82.5	92	76	13-19	228
E30Q14M	2014403	27	1164	1027	314	464	82.5	92	76	13-19	297
E30Q14H	2014404	27	1164	1027	353	464	82.5	92	76	13-19	349

# McKissick® Easy Reeve® Crane Blocks



## McKissick® Easy Reeve® Crane Blocks

Model No.	Inquiry Stock No.	Working Load Limit (t)*	A Overall Length (mm)	B Net Length (mm)	E Block Thickness (mm)	F Block Width (mm)	H Throat Opening with Flapper (mm)	J Hook Thickness (mm)	K Hook Width (mm)	Standard Wire Line Sizes (mm)	Weight Each (kg)†
<b>32 Tonnes</b>											
E35S20L	2014406	32	1502	1341	174	622	76	116	92	19-28	253
E35S20M	2014408	32	1502	1341	225	622	76	116	92	19-28	393
E35S20H	2014409	32	1502	1341	263	622	76	116	92	19-28	500
E35D18L	2014411	32	1413	1252	174	565	76	116	92	16-26	258
E35D18M	2014413	32	1413	1252	231	565	76	116	92	16-26	377
E35D18H	2014414	32	1413	1252	269	565	76	116	92	16-26	458
E35T14L	2014421	32	1267	1106	207	464	76	116	92	13-19	221
E35T14M	2014423	32	1267	1106	258	464	76	116	92	13-19	290
E35T14H	2014424	32	1267	1106	296	464	76	116	92	13-19	342
E35T16L	2014431	32	1362	1202	207	521	76	116	92	14-22	253
E35T16M	2014433	32	1362	1202	258	521	76	116	92	14-22	342
E35T16H	2014434	32	1362	1202	296	521	76	116	92	14-22	411
E35Q14L	2014441	32	1267	1106	264	464	76	116	92	13-19	252
E35Q14M	2014443	32	1267	1106	314	464	76	116	92	13-19	320
E35Q14H	2014444	32	1267	1106	353	464	76	116	92	13-19	372
<b>36 Tonnes</b>											
E40T14L	2014451	36	1319	1146	207	464	86	129	94.5	13-19	247
E40T14M	2014453	36	1319	1146	258	464	86	129	94.5	13-19	315
E40T14H	2014454	36	1319	1146	296	464	86	129	94.5	13-19	368
E40T16L	2014461	36	1415	1242	207	521	86	129	94.5	14-22	279
E40T16M	2014463	36	1415	1242	258	521	86	129	94.5	14-22	372
E40T16H	2014464	36	1415	1242	296	521	86	129	94.5	14-22	437
E40T18L	2014471	36	1465	1292	207	565	86	129	94.5	16-26	322
E40T18M	2014473	36	1465	1292	264	565	86	129	94.5	16-26	441
E40T18H	2014474	36	1465	1292	302	565	86	129	94.5	16-26	497
E40Q14L	2014481	36	1319	1146	264	464	86	129	94.5	13-19	277
E40Q14M	2014483	36	1319	1146	314	464	86	129	94.5	13-19	346
E40Q14H	2014484	36	1319	1146	353	464	86	129	94.5	13-19	398
E40Q16L	2014491	36	1415	1242	264	521	86	129	94.5	14-22	313
E40Q16M	2014493	36	1415	1242	314	521	86	129	94.5	14-22	403
E40Q16H	2014494	36	1415	1242	353	521	86	129	94.5	14-22	472
<b>40 Tonnes</b>											
E45T14L	2014501	41	1319	1146	207	464	86	129	94.5	13-19	247
E45T14M	2014503	41	1319	1146	258	464	86	129	94.5	13-19	315
E45T14H	2014504	41	1319	1146	296	464	86	129	94.5	13-19	368
E45T16L	2014511	41	1415	1242	207	521	86	129	94.5	14-22	279
E45T16M	2014513	41	1415	1242	258	521	86	129	94.5	14-22	372
E45T16H	2014514	41	1415	1242	296	521	86	129	94.5	14-22	437
E45T18L	2014521	41	1465	1292	207	565	86	129	94.5	16-26	322
E45T18M	2014523	41	1465	1292	264	565	86	129	94.5	16-26	441
E45T18H	2014524	41	1465	1292	302	565	86	129	94.5	16-26	522
E45Q14L	2014531	41	1319	1146	264	464	86	129	94.5	13-19	277
E45Q14M	2014533	41	1319	1146	314	464	86	129	94.5	13-19	346
E45Q14H	2014534	41	1319	1146	353	464	86	129	94.5	13-19	398
E45Q16L	2014541	41	1415	1242	264	521	86	129	94.5	14-22	313
E45Q16M	2014543	41	1415	1242	314	521	86	129	94.5	14-22	403
E45Q16H	2014544	41	1415	1242	353	521	86	129	94.5	14-22	472
<b>45 Tonnes</b>											
E50T18L	2014551	45	1619	1403	283	565	105	152	113	16-26	474
E50T18M	2014553	45	1619	1403	340	565	105	152	113	16-26	593
E50T18H	2014554	45	1619	1403	378	565	105	152	113	16-26	674
E50Q16L	2014561	45	1568	1353	338	521	105	152	113	14-22	484
E50Q16M	2014563	45	1568	1353	389	521	105	152	113	14-22	551
E50Q16H	2014564	45	1568	1353	427	521	105	152	113	14-22	642
E50QN16L	2014571	45	1568	1353	357	521	105	152	113	14-22	520
E50QN16M	2014573	45	1568	1353	408	521	105	152	113	14-22	610
E50QN16H	2014574	45	1568	1353	446	521	105	152	113	14-22	678
<b>50 Tonnes</b>											
E55T18L	2014581	50	1619	1403	283	565	105	152	113	16-26	474
E55T18M	2014583	50	1619	1403	340	565	105	152	113	16-26	593
E55T18H	2014584	50	1619	1403	378	565	105	152	113	16-26	674
E55Q16L	2014591	50	1568	1353	338	521	105	152	113	14-22	484
E55Q16M	2014593	50	1568	1353	389	521	105	152	113	14-22	574
E55Q16H	2014594	50	1568	1353	427	521	105	152	113	14-22	642
E55QN16L	2014601	50	1568	1353	357	521	105	152	113	14-22	520
E55QN16M	2014603	50	1568	1353	408	521	105	152	113	14-22	610
E55QN16H	2014604	50	1568	1353	446	521	105	152	113	14-22	678

**McKISSICK® BLOCKS**

# McKissick® Easy Reeve® Crane Blocks

## McKissick® Easy Reeve® Crane Blocks

Model No.	Inquiry Stock No.	Working Load Limit (t)*	A Overall Length (mm)	B Net Length (mm)	E Block Thickness (mm)	F Block Width (mm)	H Throat Opening with Flapper (mm)	J Hook Thickness (mm)	K Hook Width (mm)	Standard Wire Line Sizes (mm)	Weight Each (kg)†
<b>54 Tonnes</b>											
E60T20L	2014611	54	1708	1492	283	622	105	152	113	19-28	531
E60T20M	2014613	54	1708	1492	334	622	105	152	113	19-28	668
E60T20H	2014614	54	1708	1492	372	622	105	152	113	19-28	758
E60Q18L	2014621	54	1619	1403	338	565	105	152	113	16-26	521
E60Q18M	2014623	54	1619	1403	395	565	105	152	113	16-26	640
E60Q18H	2014624	54	1619	1403	433	565	105	152	113	16-26	721
E60QN18L	2014631	54	1619	1403	357	565	105	152	113	16-26	550
E60QN18M	2014633	54	1619	1403	414	565	105	152	113	16-26	670
E60QN18H	2014634	54	1619	1403	452	565	105	152	113	16-26	750
E60QN20L	2014641	54	1708	1492	357	622	105	152	113	19-28	628
E60QN20M	2014643	54	1708	1492	408	622	105	152	113	19-28	765
E60QN20H	2014644	54	1708	1492	446	622	105	152	113	19-28	855
<b>59 Tonnes</b>											
E65T20L	2014651	59	1708	1492	283	622	105	152	113	19-28	531
E65T20M	2014653	59	1708	1492	334	622	105	152	113	19-28	668
E65T20H	2014654	59	1708	1492	372	622	105	152	113	19-28	758
E65Q18L	2014661	59	1619	1403	338	565	105	152	113	16-26	521
E65Q18M	2014663	59	1619	1403	395	565	105	152	113	16-26	640
E65Q18H	2014664	59	1619	1403	433	565	105	152	113	16-26	721
E65QN18L	2014671	59	1619	1403	357	565	105	152	113	16-26	550
E65QN18M	2014673	59	1619	1403	414	565	105	152	113	16-26	670
E65QN18H	2014674	59	1619	1403	452	565	105	152	113	16-26	750
E65QN20L	2014681	59	1708	1492	357	622	105	152	113	19-28	628
E65QN20M	2014683	59	1708	1492	408	622	105	152	113	19-28	765
E65QN20H	2014684	59	1708	1492	446	622	105	152	113	19-28	855
<b>63 Tonnes</b>											
E70T20L	2014691	63	1884	1651	283	622	137	170	122	19-28	626
E70T20M	2014693	63	1884	1651	334	622	137	170	122	19-28	762
E70T20H	2014694	63	1884	1651	372	622	137	170	122	19-28	853
E70Q18L	2014701	63	1796	1562	338	565	137	170	122	16-26	658
E70Q18M	2014703	63	1796	1562	395	565	137	170	122	16-26	777
E70Q18H	2014704	63	1796	1562	433	565	137	170	122	16-26	858
E70QN18L	2014711	63	1796	1562	357	565	137	170	122	16-26	629
E70QN18M	2014713	63	1796	1562	414	565	137	170	122	16-26	748
E70QN18H	2014714	63	1796	1562	452	565	137	170	122	16-26	830
E70QN20L	2014721	63	1884	1651	357	622	137	170	122	19-28	754
E70QN20M	2014723	63	1884	1651	408	622	137	170	122	19-28	891
E70QN20H	2014724	63	1884	1651	446	622	137	170	122	19-28	982
<b>68 Tonnes</b>											
E75T20L	2014731	68	1884	1651	283	622	137	170	122	19-28	626
E75T20M	2014733	68	1884	1651	334	622	137	170	122	19-28	762
E75T20H	2014734	68	1884	1651	372	622	137	170	122	19-28	853
E75Q18L	2014741	68	1796	1562	338	565	137	170	122	16-26	658
E75Q18M	2014743	68	1796	1562	395	565	137	170	122	16-26	777
E75Q18H	2014744	68	1796	1562	433	565	137	170	122	16-26	858
E75QN18L	2014751	68	1796	1562	357	565	137	170	122	16-26	629
E75QN18M	2014753	68	1796	1562	414	565	137	170	122	16-26	748
E75QN18H	2014754	68	1796	1562	452	565	137	170	122	16-26	830
E75QN20L	2014761	68	1884	1651	357	622	137	170	122	19-28	754
E75QN20M	2014763	68	1884	1651	408	622	137	170	122	19-28	891
E75QN20H	2014764	68	1884	1651	446	622	137	170	122	19-28	982
<b>72 Tonnes</b>											
E80T20L	2014771	72	1884	1651	283	622	137	170	122	19-28	626
E80T20M	2014773	72	1884	1651	334	622	137	170	122	19-28	762
E80T20H	2014774	72	1884	1651	372	622	137	170	122	19-28	853
E80Q18L	2014781	72	1796	1562	338	565	137	170	122	16-26	658
E80Q18M	2014783	72	1796	1562	395	565	137	170	122	16-26	777
E80Q18H	2014784	72	1796	1562	433	565	137	170	122	16-26	858
E80QN18L	2014791	72	1796	1562	357	565	137	170	122	16-26	629
E80QN18M	2014793	72	1796	1562	414	565	137	170	122	16-26	748
E80QN18H	2014794	72	1796	1562	452	565	137	170	122	16-26	830
E80QN20L	2014801	72	1884	1651	357	622	137	170	122	19-28	754
E80QN20M	2014803	72	1884	1651	408	622	137	170	122	19-28	891
E80QN20H	2014804	72	1884	1651	446	622	137	170	122	19-28	982

\* Ultimate Load is 4 times the Working Load Limit.

† Additional cheek weight kits are available.





## 790 SERIES METRIC EASY REEVE® HOOK BLOCKS

- Wide range of product available.
  - Capacity: 4,5 to 72t - Larger Models Available.
  - Sheave Sizes: 254 to 508mm.
  - Wireline Sizes: 11 to 28mm.
- All single point shank hooks are genuine Crosby®, forged alloy steel, Quenched and Tempered, and have the patented **QUIC-CHECK®** markings (Duplex hooks are available on most sizes).
- Design factor of 4 to 1 (unless otherwise noted).
- All Easy Reeve® Blocks are furnished standard with Roller Bearings.
- Reeving Guides Standard – All Models.
- Blocks thru 20t use 319N hooks with S-4320 latches.
- Heavy Duty Positive Locking (PL) Latch – Models: 25t and larger.
- Sheave lubrication through center pin - separate lube channel to

- each bearing.
- Sheaves fully protected by side plates.
- Dual action hook (swings and rotates).
- Repair parts available through worldwide distribution network.
- All Easy Reeve® blocks, 4406mm and larger, are furnished with McKissick® Roll-Forged™ sheaves with flame hardened grooves.
- Manufactured by an ISO 9001 and API Q1 certified facility.
- “Look for the Orange Hook . . . the mark of genuine McKissick® quality”.



**Center “Dead End”**  
to promote better block travel under various reeving configurations.



### OPTIONS AVAILABL

- DIN 15402 Hooks - “Rams Horn”
- Swivel Tee and Shackle Assemblies
- Sheave Shrouds
- Heavy Duty Latch
- Third party testing with Certification available upon request.
- McKissick Split-Nut® retention system



**Flat Bottom** side plate for self standing during reeving process.

# McKissick® Metric Easy Reeve® Crane Blocks

Table - Standard WireLine Sizes For McKissick® 790 Crane Blocks																																			
Sheave Diameter (mm)	Sheave WireLine Size (mm)																																		
	12	13	14	15	16	17	18	19	20	21	22	23	24	25	26	27	28	29	30	32															
300	■	■	■	■																															
350				■	■	■																													
400					■	■	■	■																											
450						■	■	■	■	■																									
500							■	■	■	■	■	■																							
550								■	■	■	■	■	■	■																					
600									■	■	■	■	■	■	■	■																			
650										■	■	■	■	■	■	■	■	■																	

Key to McKissick® Metric Crane Block Model Numbers					
ME	10	S	35	S	1
McKissick® Metric Crane Block	Working Load Limit (t)	Number of Sheaves	Sheave Diameter (O.D.) (mm)	Block Weight	Hook Type
		S = 1 D = 2 T = 3 Q = 4 QN = 5	Multiply Value times 10 (i.e., 35 = 350mm)	S = Standard W = Weighted	1 = Din 15401 2 = Din 15402

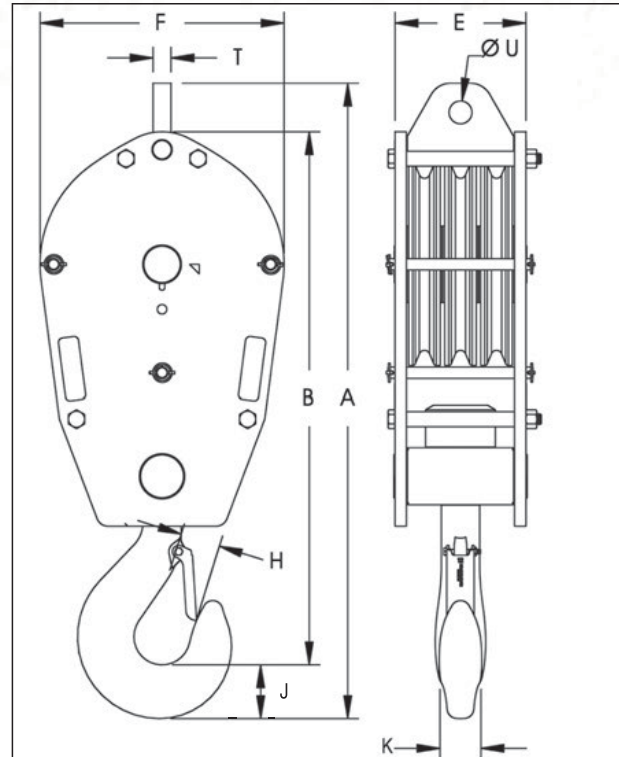

## McKissick Metric Easy Reeve® Crane Blocks

Model Number	Inquiry Stock Number	Working Load Limit (t)	A Overall Length (mm)	B Net Length (mm)	E Thickness (mm)	F Width (mm)	H Throat Opening (mm)	J Hook Thickness (mm)	K Hook Width (mm)	Standard Wireline Sizes (mm)	Dead End		Weight Each (kg)
											T Thickness (mm)	U Pin Hole (mm)	
<b>8 Tonnes</b>													
ME8S30S1	2035000	8	1008	861	138	392	56	67	53	12,13,14,15	22	44	95
ME8S30W1	2035003	8	1008	861	240	392	56	67	53	12,13,14,15	22	44	168
<b>10 Tonnes</b>													
ME10S35S1	2035006	10	1058	911	138	442	56	67	53	14, 15, 16, 17	22	44	108
ME10S35W1	2035009	10	1058	911	240	442	56	67	53	14, 15, 16, 17	22	44	190
ME10S40S1	2035012	10	1158	1011	138	492	56	67	53	17, 18, 19, 20	22	44	132
ME10S40W1	2035015	10	1158	1011	240	492	56	67	53	17, 18, 19, 20	22	44	245
ME10D30S1	2035018	10	1008	861	138	392	56	67	53	12, 13, 14, 15	22	44	108
ME10D30W1	2035021	10	1008	861	240	392	56	67	53	12, 13, 14, 15	22	44	176
<b>15 Tonnes</b>													
ME15S35S1	2035024	15	1058	911	138	442	56	67	53	14, 15, 16, 17	22	44	109
ME15S35W1	2035027	15	1058	911	240	442	56	67	53	14, 15, 16, 17	22	44	191
ME15S40S1	2035030	15	1158	1011	138	492	56	67	53	17, 18, 19, 20	22	43	134
ME15S40W1	2035033	15	1158	1011	240	492	56	67	53	17, 18, 19, 20	22	43	258
ME15S45S1	2035036	15	1218	1071	138	542	56	67	53	19, 20, 21	22	43	148
ME15S45W1	2035039	15	1218	1071	240	542	56	67	53	19, 20, 21	22	43	279
ME15D35S1	2035042	15	1058	911	138	442	56	67	53	14, 15, 16, 17	22	43	108
ME15D35W1	2035045	15	1058	911	240	442	56	67	53	14, 15, 16, 17	22	43	205
<b>20 Tonnes</b>													
ME20S45S1	2035048	20	1291	1115	153	542	71	85	67	19, 20, 21	30	43	172
ME20S45W1	2035051	20	1291	1115	255	542	71	85	67	19, 20, 21	30	43	307
ME20S50S1	2035054	20	1369	1193	153	592	71	85	67	21, 22, 23	30	59	198
ME20S50W1	2035057	20	1369	1193	255	592	71	85	67	21, 22, 23	30	59	365
ME20D40S1	2035060	20	1236	1060	153	492	71	85	67	17, 18, 19, 20	30	59	174
ME20D40W1	2035063	20	1236	1060	255	492	71	85	67	17, 18, 19, 20	30	59	293
ME20T35S1	2035066	20	1137	985	176	442	71	85	67	14, 15, 16, 17	30	43	162
ME20T35W1	2035069	20	1137	985	278	442	71	85	67	14, 15, 16, 17	30	43	253
<b>25 Tonnes</b>													
ME25S55S1	2035072	25	1421	1245	153	642	71	85	67	23, 24, 25, 26, 27	30	43	222
ME25S55W1	2035075	25	1421	1245	255	642	71	85	67	23, 24, 25, 26, 27	30	43	410
ME25S60S1	2035078	25	1481	1305	153	692	71	85	67	27, 28, 29	30	59	247
ME25S60W1	2035081	25	1481	1305	255	692	71	85	67	27, 28, 29	30	59	461
ME25D45S1	2035084	25	1291	1115	153	542	71	85	67	19, 20, 21	30	43	187
ME25D45W1	2035087	25	1291	1115	255	542	71	85	67	19, 20, 21	30	43	323
ME25D50S1	2035090	25	1369	1193	153	592	71	85	67	21, 22, 23	30	43	224
ME25D50W1	2035093	25	1369	1193	255	592	71	85	67	21, 22, 23	30	43	389
ME25T35S1	2035096	25	1137	985	176	442	71	85	67	14, 15, 16, 17	30	43	162

# McKissick® Metric Easy Reeve® Crane Blocks

## McKissick Metric Easy Reeve® Crane Blocks

Model Number	Inquiry Stock Number	Working Load Limit (t)	A Overall Length (mm)	B Net Length (mm)	E Thickness (mm)	F Width (mm)	H Throat Opening (mm)	J Hook Thickness (mm)	K Hook Width (mm)	Standard Wireline Sizes (mm)	Dead End		Weight Each (kg)
											T Thickness (mm)	U Pin Hole (mm)	
ME25T35W1	2035099	25	1137	985	278	442	71	85	67	14, 15, 16, 17	30	43	253
<b>32 Tonnes</b>													
ME32S65S1	2035102	32	1678	1469	188	742	80	95	75	28, 29, 30, 32	38	65	314
ME32S65W1	2035105	32	1678	1469	290	742	80	95	75	28, 29, 30, 32	38	65	585
ME32D50S1	2035108	32	1442	1259	188	592	80	95	75	21, 22, 23	38	65	257
ME32D50W1	2035111	32	1442	1259	290	592	80	95	75	21, 22, 23	38	65	424
ME32D55S1	2035114	32	1492	1309	188	642	80	95	75	23, 24, 25, 26, 27	38	65	286
ME32D55W1	2035117	32	1492	1309	290	642	80	95	75	23, 24, 25, 26, 27	38	65	489
ME32T40S1	2035120	32	1303	1094	218	492	80	95	75	17, 18, 19, 20	30	43	230
ME32T40W1	2035123	32	1303	1094	320	492	80	95	75	17, 18, 19, 20	30	43	356
<b>35 Tonnes</b>													
ME35D50S1	2035126	35	1442	1259	188	592	80	95	75	21, 22, 23	38	65	257
ME35D50W1	2035129	35	1442	1259	290	592	80	95	75	21, 22, 23	38	65	424
ME35D55S1	2035132	35	1492	1309	188	642	80	95	75	23, 24, 25, 26, 27	38	65	286
ME35D55W1	2035135	35	1492	1309	290	642	80	95	75	23, 24, 25, 26, 27	38	65	489
ME35T45S1	2035138	35	1333	1094	218	542	80	95	75	19, 20, 21	38	65	230
ME35T45W1	2035141	35	1333	1094	320	542	80	95	75	19, 20, 21	38	65	356
<b>40 Tonnes</b>													
ME40T45S1	2035144	40	1325	1123	252	542	90	106	85	19, 20, 21	36	53	316
ME40T45W1	2035147	40	1325	1123	353	542	90	106	85	19, 20, 21	36	53	442
ME40T50S1	2035150	40	1375	1173	252	592	90	106	85	21, 22, 23	36	53	361
ME40T50W1	2035153	40	1375	1173	353	592	90	106	85	21, 22, 23	36	53	528
ME40Q40S1	2035156	40	1280	1078	319	542	90	106	85	17, 18, 19, 20	38	65	343
ME40Q40W1	2035159	40	1280	1078	420	542	90	106	85	17, 18, 19, 20	38	65	469
<b>45 Tonnes</b>													
ME45T45S1	2035162	45	1325	1123	252	542	90	106	85	19, 20, 21	36	53	316
ME45T45W1	2035165	45	1325	1123	353	542	90	106	85	19, 20, 21	36	53	442
ME45T50S1	2035168	45	1375	1173	252	592	90	106	85	21, 22, 23	36	53	361
ME45T50W1	2035171	45	1375	1173	353	592	90	106	85	21, 22, 23	36	53	528
ME45Q45S1	2035174	45	1310	1108	319	542	90	106	85	19, 20, 21	38	65	359
ME45Q45W1	2035177	45	1310	1108	420	542	90	106	85	19, 20, 21	38	65	488
<b>50 Tonnes</b>													
ME50T45S1	2035180	50	1412	1185	291	542	100	118	95	19, 20, 21	36	59	361
ME50T45W1	2035183	50	1412	1185	392	542	100	118	95	19, 20, 21	36	59	743
ME50T50S1	2035186	50	1462	1245	291	592	100	118	95	21, 22, 23	36	59	405
ME50T50W1	2035189	50	1462	1245	392	592	100	118	95	21, 22, 23	36	59	567
ME50Q45S1	2035192	50	1412	1185	319	542	100	118	95	19, 20, 21	38	65	390
ME50Q45W1	2035195	50	1412	1185	420	542	100	118	95	19, 20, 21	38	65	545
ME50QN45S1	2035198	50	1412	1185	532	542	100	118	95	19, 20, 21	38	65	578
ME50QN45W1	2035201	50	1412	1185	634	542	100	118	95	19, 20, 21	38	65	775
<b>55 Tonnes</b>													
ME55T55S1	2035204	55	1512	1295	291	642	100	118	95	23, 24, 25, 26, 27	36	59	461
ME55T55W1	2035207	55	1512	1295	392	642	100	118	95	23, 24, 25, 26, 27	36	59	651
ME55Q45S1	2035210	55	1412	1185	319	542	100	118	95	19, 20, 21	36	59	390
ME55Q45W1	2035213	55	1412	1185	420	542	100	118	95	19, 20, 21	36	59	545
ME55QN45S1	2035216	55	1412	1185	532	542	100	118	95	19, 20, 21	38	65	578
ME55QN45W1	2035219	55	1412	1185	634	542	100	118	95	19, 20, 21	38	65	775
<b>60 Tonnes</b>													
ME60T55S1	2035222	60	1512	1295	291	642	100	118	95	23, 24, 25, 26, 27	36	59	461
ME60T55W1	2035225	60	1512	1295	392	642	100	118	95	23, 24, 25, 26, 27	36	59	651
ME60Q45S1	2035228	60	1412	1185	319	542	100	118	95	19, 20, 21	38	65	390
ME60Q45W1	2035231	60	1412	1185	420	542	100	118	95	19, 20, 21	38	65	545
ME60QN45S1	2035234	60	1412	1185	532	542	100	118	95	19, 20, 21	38	65	578
ME60QN45W1	2035237	60	1412	1185	634	542	100	118	95	19, 20, 21	38	65	775
<b>70 Tonnes</b>													
ME70T65S1	2035240	70	1750	1518	291	742	112	132	106	28, 29, 30, 32	44	65	617
ME70T65W1	2035243	70	1750	1518	392	742	112	132	106	28, 29, 30, 32	44	65	895
ME70Q60S1	2035246	70	1700	1468	371	692	112	132	106	27, 28, 29, 30	44	65	694
ME70Q60W1	2035249	70	1700	1468	422	692	112	132	106	27, 28, 29, 30	44	65	950
ME70QN45S1	2035252	70	1470	1228	532	542	112	132	106	19, 20, 21	38	65	657
ME70QN45W1	2035255	70	1470	1228	634	542	112	132	106	19, 20, 21	38	65	882
<b>80 Tonnes</b>													
ME80T65S1	2035258	80	1750	1518	291	742	112	132	106	28, 29, 30, 32	44	65	617
ME80T65W1	2035261	80	1750	1518	392	742	112	132	106	28, 29, 30, 32	44	65	895
ME80QN45S1	2035270	80	1470	1228	532	542	112	132	106	19, 20, 21	38	65	657
ME80QN45W1	2035273	80	1470	1228	634	542	112	132	106	19, 20, 21	38	65	882
ME80QN50S1	2035264	80	1520	1288	532	592	112	132	106	21, 22, 23	38	65	723
ME80QN50W1	2035267	80	1520	1288	634	592	112	132	106	21, 22, 23	38	65	812



# Innovative McKissick Split-Nut Retention System Makes Inspection Easier

## Crane Block Hook Inspection in 4 Easy Steps

**STEP 1**  
Remove protective vinyl cover



**STEP 2**  
Remove retaining ring



**STEP 3**  
Slide keeper ring off split nuts



**STEP 4**  
Easily remove split nut halves to inspect shank hook



Shank hooks on crane blocks must be inspected in accordance with applicable ASME B30, CSA Z150 and other crane standards. These standards mandate the crane hook to be inspected for surface indications, damage and corrosion which could compromise the integrity of the crane block. Because of the type of environment in which these hooks are required to perform, the removal of corroded nuts from the threads can become a problem during inspections. The innovative patented\* Split-Nut Retention System featured on McKissick® crane blocks makes inspection easier. With 4 easy steps, the hook can be disassembled, inspected and put back into service in a fraction of the time of a conventional threaded nut.

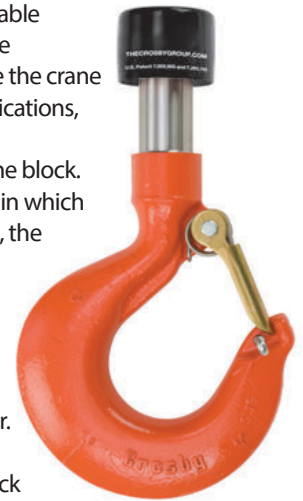

**Fatigue Rated®**

The Split-Nut is standard equipment on McKissick® Easy Reeve® crane blocks up to 100 tons.

- Allows for easy inspection as required by ASME B30, CSA Z150 and other crane standards
- Eliminates conventional threaded nut and problems associated with the nut removal for inspection.
- Allows repeated installation and removal without risk of damage to hook/nut interface.
- Zinc plated finish for corrosion resistance
- Replacement hook and trunnion assemblies available for selected McKissick® 380, or Easy Reeve® & 790 blocks with threaded hooks.

The new patented\* Split-Nut can be purchased in a variety of configurations that can be used to retrofit the following McKissick® blocks in the field or in the shop.

- Over 80 tons and larger crane blocks, upon request
- Bridge crane blocks
- 80 Series tubing blocks

In addition, the Split-Nut can be used to replace existing hooks on existing crane blocks currently in the field (most manufacturers makes and models) and on special designed lifting equipment.

**McKISSICK®**  
Your Total Block Company

**Crosby®**

Tulsa, Oklahoma • Phone: (918) 834-4611  
www.thecrosbygroup.com

\* U.S. Patent 7,000,905 & 7,293,763

# McKissick® Scrap Handling Blocks



**381-SY**  
Scrap Handling  
Blocks

- All single point shank hooks are genuine Crosby®, forged alloy steel, Quenched and Tempered, and have the patented **QUIC-CHECK®** markings.
- Durable - Allows longer continuous duty cycle.
- Can be used with magnet and drop ball.
- Single sheave design.
- Dual action hook (Swings and Rotates).
- Utilizes McKissick® Roll-Forged sheaves with flame hardened grooves.
- Furnished standard with Bronze Bushed Sheaves.
- Optional Tapered Roller Bearings.
- All sizes are **RFID EQUIPPED**.

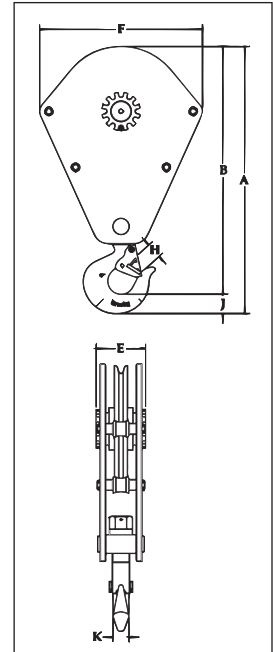

## 381-SY Scrap Handling Blocks

Model No.	381-SY Inquiry Stock No.	Working Load Limit (t)*	Sheave Diameter (mm)	Standard Wireline (mm)	Weight Each (kg)	Dimensions (mm)						
						A	B	E	F	H	J	K
S15S16L	2014810	13.5	406	14-22	129	944	868	161	578	70.0	75.5	60.5
S20S18L	2014812	18.0	457	16-25	179	1004	929	174	629	70.0	75.5	60.5
S25S20L	2014814	22.5	508	19-28	209	1071	995	174	679	70.0	75.5	60.5
S30S24L	2014816	27.0	610	22-32	320	1281	1189	199	781	82.5	92.0	76.0
S40S24L	2014818	36.0	610	22-32	370	1418	1289	199	781	86.0	129	82.5

\* Ultimate Load is 4 times the Working Load Limit.



**TU-481c**

**Wide Range of Sizes Available:**

- 30 and 60 Ton (27 and 54 Tonnes) Capacity
- 1" to 2-1/4" (25mm to 60mm) Wireline Size
- 16" to 24" (406mm to 610mm) Sheave Diameter
- Larger Capacity Blocks available.

**Multiple Configurations Available:**

- Swivel Hook
- Swivel Shackle
- Tailboard
- Upset Shackle
- Fixed Shackle

**McKissick Roll-Forged Sheaves:**

- Flame Hardened Grooves
- 30 Ton (27 Tonnes) furnished with Roller Bearings
- 60 Ton (54 Tonnes) furnished with Tapered Roller Bearings with seals
- All sizes are **RFID EQUIPPED**.
- Meets or exceeds all requirements of ASME B30.26 including identification, ductility, design factor, proof load and temperature requirements. Importantly, these blocks meet other critical performance requirements including fatigue life, impact properties and material traceability, not addressed by ASME B30.26.

**TU-480 SERIES BLOCKS**

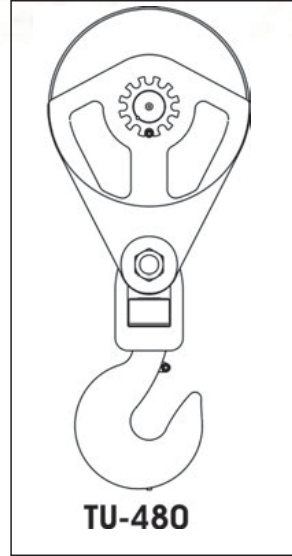

**TU-480**

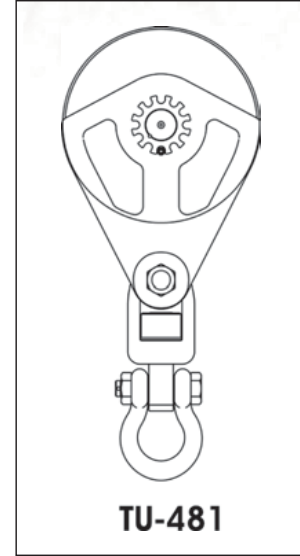

**TU-481**



**TU-480 / TU-481 High Capacity Snatch Blocks for Tilt-Up Wall Construction**

Working Load Limit (t)*	Sheave Diameter (mm)	Wire Line Size (mm)	With Swivel Hook		With Swivel Shackle	
			TU-480 Stock No.	TU-480 Weight Each (kg)	TU-481 Stock No.	TU-481 Weight Each (kg)
27	406	25	2108300	102	2108303	107
27	406	28	2108312	102	2108315	107
27	406	32	2108324	102	2108327	107
27	406	35	2108336	102	2108339	107
27	406	38	2108348	102	2108351	107
27	508	25	2108360	109	2108363	113
27	508	28	2108372	109	2108375	113
27	508	32	2108384	109	2108387	113
27	508	35	2108396	109	2108399	113
27	508	38	2108408	109	2108411	113
54	457	25	2108420	177	2108423	177
54	457	28	2108435	177	2108438	177
54	457	32	2108450	177	2108453	177
54	457	35	2108465	177	2108468	177
54	457	38	2108480	177	2108483	177
54	610	25	2108495	204	2108498	204
54	610	28	2108510	204	2108513	204
54	610	32	2108525	204	2108528	204
54	610	35	2108540	204	2108543	204
54	610	38	2108555	204	2108558	204
54	610	41	2108570	204	2108573	204
54	610	44	2108585	204	2108588	204
54	610	48	2108600	204	2108603	204
54	610	51	2108615	204	2108618	204
54	610	57	2108630	204	2108633	204

\* Ultimate Load is 4 times the Working Load Limit.

Contact our Block Hotline (800)772-1555 for blocks up to 350 Tons or reference the special request form on page 461.



# McKissick® Tilt-Up Wall Blocks



## Wide Range of Sizes Available:

- 30 and 60 Ton (27 and 54 Tonnes) Capacity
- 1" to 2-1/4" (25mm to 60mm) Wireline Size
- 16" to 24" (406mm to 610mm) Sheave Diameter
- Larger Capacity Blocks available.

## Multiple Configurations Available:

- Swivel Hook
- Swivel Shackle
- Tailboard
- Upset Shackle
- Fixed Shackle

## McKissick Roll-Forged Sheaves:

- Flame Hardened Grooves
- 30 Ton (27 Tonnes) furnished with Roller Bearings
- 60 Ton (54 Tonnes) furnished with Tapered Roller Bearings with seals
- All sizes are **RFID EQUIPPED**.
- Meets or exceeds all requirements of ASME B30.26 including identification, ductility, design factor, proof load and temperature requirements. Importantly, these blocks meet other critical performance requirements including fatigue life, impact properties and material traceability, not addressed by ASME B30.26.

## TU-480 SERIES BLOCKS

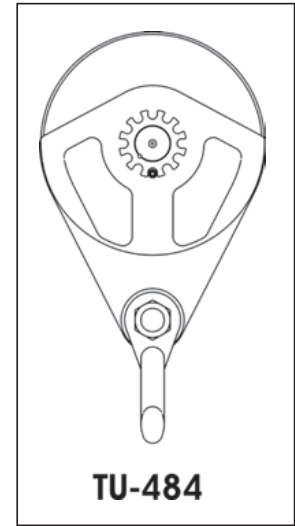
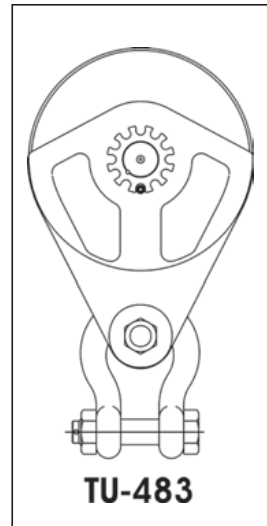
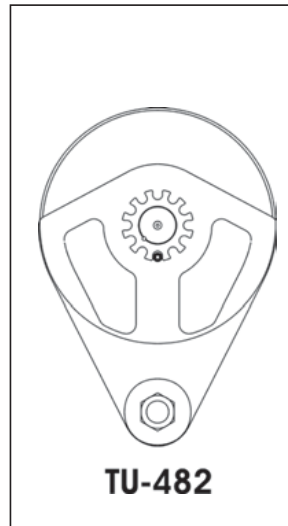

## TU-482 / TU-483 / TU-484 High Capacity Snatch Blocks for Tilt-Up Wall Construction

Working Load Limit (t)*	Sheave Diameter (mm)	Wireline Size (mm)	Tailboard Style		With Upset Shackle		With Fixed Shackle	
			TU-482 Stock No.	TU-482 Weight Each (kg)	TU-483 Stock No.	TU-483 Weight Each (kg)	TU-484 Stock No.	TU-484 Weight Each (kg)
27	406	25	2108306	63.5	2108309	81.6	2108645	72.6
27	406	28	2108318	63.5	2108321	81.6	2108648	72.6
27	406	32	2108330	63.5	2108333	81.6	2108651	72.6
27	406	35	2108342	63.5	2108345	81.6	2108654	72.6
27	406	38	2108354	63.5	2108357	81.6	2108657	72.6
27	508	25	2108366	70.3	2108369	88.5	2108660	79.4
27	508	28	2108378	70.3	2108381	88.5	2108663	79.4
27	508	32	2108390	70.3	2108393	88.5	2108666	79.4
27	508	35	2108402	70.3	2108405	88.5	2108669	79.4
27	508	38	2108414	70.3	2108417	88.5	2108672	79.4
54	457	25	2108426	104	2108429	154	2108432	132
54	457	28	2108441	104	2108444	154	2108447	132
54	457	32	2108456	104	2108459	154	2108462	132
54	457	35	2108471	104	2108474	154	2108477	132
54	457	38	2108486	104	2108489	154	2108492	132
54	610	25	2108501	132	2108504	181	2108507	159
54	610	28	2108516	132	2108519	181	2108522	159
54	610	32	2108531	132	2108534	181	2108537	159
54	610	35	2108546	132	2108549	181	2108552	159
54	610	38	2108561	132	2108564	181	2108567	159
54	610	41	2108576	132	2108579	181	2108582	159
54	610	44	2108591	132	2108594	181	2108597	159
54	610	48	2108606	132	2108609	181	2108612	159
54	610	51	2108621	132	2108624	181	2108627	159
54	610	57	2108636	132	2108639	181	2108642	159

\* Ultimate Load is 4 times the Working Load Limit.

Contact our Block Hotline (800)772-1555 for blocks up to 350 Tons or reference the special request form on page 461.



**680**  
Construction Block  
with Shackle



**680**  
Construction Block  
with Hanger



**680**  
Construction Block  
Bolt only



## 680 Construction Blocks

- Wide Range of products available.
- Capacity: 4,5 to 90t – Larger models available.
- Sheave sizes: 152 to 610mm O.D.
- Wireline Sizes: 10 to 32mm
- Equipped with genuine Crosby® forged steel, Quenched and Tempered shackles that contain the patented **QUIC-CHECK®** markings.
- Design Factor of 4 to 1.
- All 680 Series Blocks are furnished standard with Bronze Bushings.
- All 680 blocks 406mm and larger, are furnished with McKissick® Roll-Forged sheaves with flame hardened grooves.
- Sheaves are lubricated through center pin, with a separate lube channel to each bearing.
- Single sheave blocks have thimble dead end.
- Manufactured by an ISO 9001 and API Q1 Certified facility.
- Meets or exceeds all requirements of ASME B30.26 including identification, ductility, design factor, proof load and temperature requirements. Importantly, these blocks meet other critical performance requirements including fatigue life, impact properties and material traceability, not addressed by ASME B30.26.

### OPTIONS AVAILABLE

- Roller bearing sheaves
- Hanger and Bolt Only models available
- Third party testing with certification
- Galvanized finish – Most models



## “P” Fitting – Block with Bolt Only

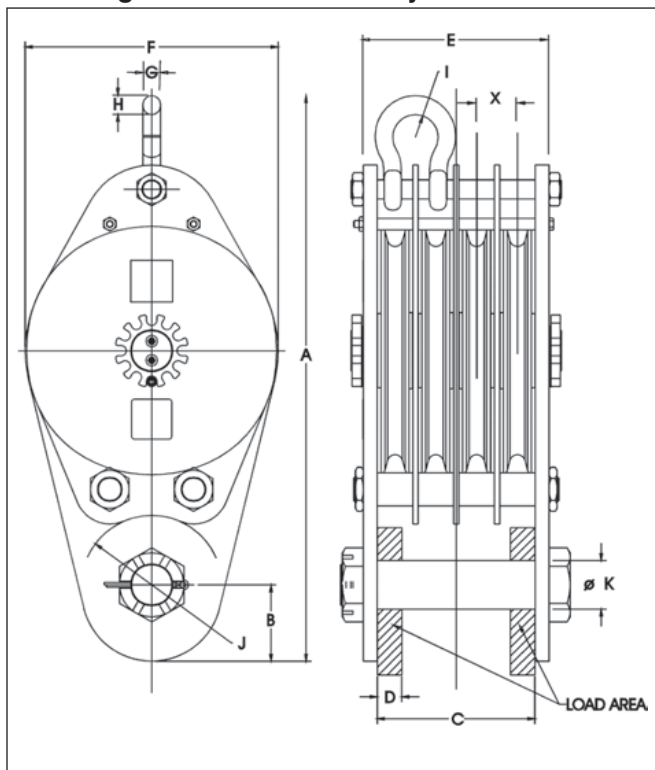

## “H” Fitting – Block with Hanger Only

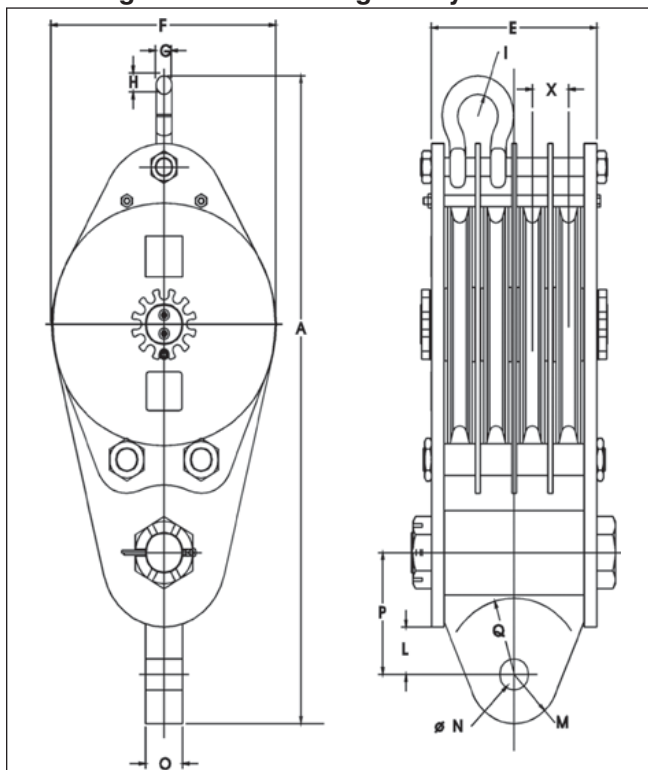

## Block Loading Area

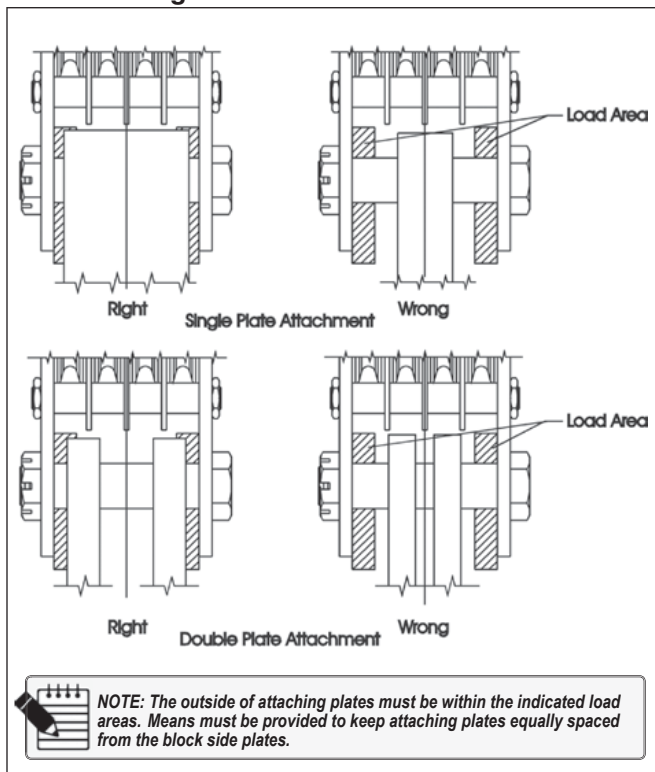

## “S” Fitting – Block with Hanger and Shackle

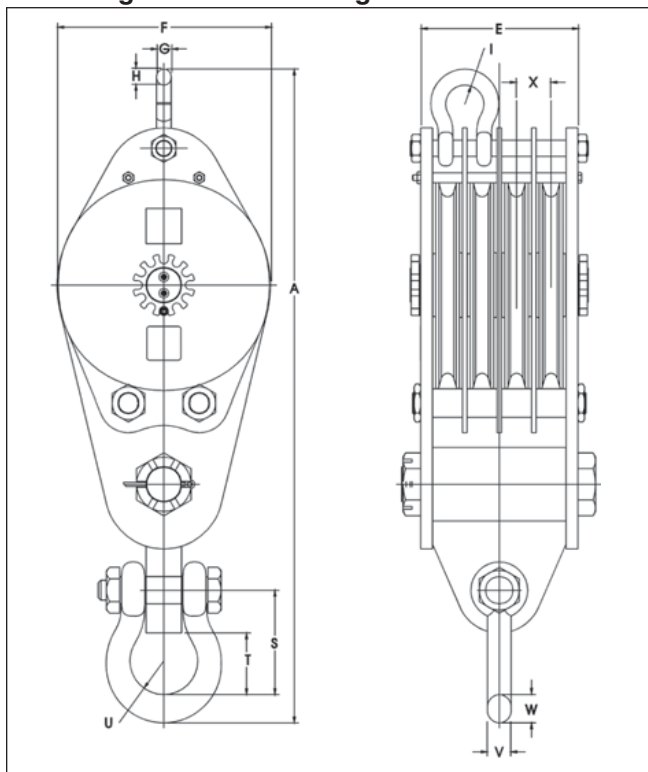



## 680 BLOCKS – “P” FITTING

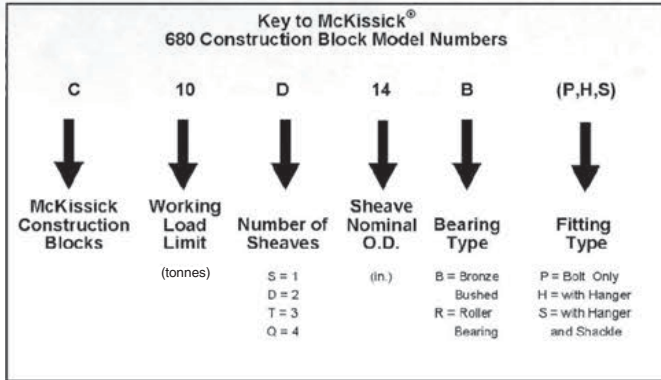

Sheave Diameter (in.)	WireLine Size (in.)									
	3/8	7/16	1/2	9/16	5/8	3/4	7/8	1	1-1/8	1-1/4
6										
8										
10										
12										
14										
16										
18										
20										
24										



All sizes are RFID EQUIPPED.

### 680 Blocks – “P” Fitting – Blocks with Bolt Only – See Drawing on Page 339

Model No.	680-P Inquiry Stock No.	Working Load Limit (t)	No. of Sheaves	Sheave Diam. (mm)	Dimensions (mm)											Weight Each (kg)	
					A	B	C	D	E	F	G	H	I	J	K		X
<b>4.5 Tonnes</b>																	
C5S6BP	2101000	4.5	1	152	308	41.1	45.2	—	58	155	—	—	—	51	31.8	—	8.6
C5S8BP	2101002	4.5	1	203	356	41.1	45.2	—	58	206	—	—	—	51	31.8	—	14.1
C5D6BP	2101010	4.5	2	152	375	41.1	97	26.9	109	155	16	17.5	21.3	45.5	31.8	51.5	15
C5D8BP	2101012	4.5	2	203	422	41.1	97	26.9	109	206	16	17.5	21.3	45.5	31.8	51.5	24.5
C5T6BP	2101020	4.5	3	152	375	41.1	148	26.9	161	155	16	17.5	21.3	45.5	31.8	51.5	20.4
C5T8BP	2101022	4.5	3	203	422	41.1	148	26.9	161	206	16	17.5	21.3	45.5	31.8	51.5	34
<b>6.8 Tonnes</b>																	
C7S6BP	2101050	6.8	1	152	308	41.1	45.2	—	58	155	—	—	—	51	31.8	—	8.6
C7S8BP	2101052	6.8	1	203	356	41.1	45.2	—	58	206	—	—	—	51	31.8	—	14.1
C7D6BP	2101060	6.8	2	152	375	41.1	97	—	109	155	—	—	—	45.5	31.8	51.5	15
C7D8BP	2101062	6.8	2	203	422	41.1	97	15.7	109	206	16	17.5	21.3	45.5	31.8	51.5	24.5
C7T6BP	2101070	6.8	3	152	375	41.1	148	15.7	161	155	16	17.5	21.3	45.5	31.8	51.5	20.4
C7T8BP	2101072	6.8	3	203	422	41.1	148	15.7	161	206	16	17.5	21.3	45.5	31.8	51.5	34
<b>9.1 Tonnes</b>																	
C10S8BP	2101100	9.1	1	203	384	54	45.2	—	58	206	—	—	—	60.5	38.1	—	15.4
C10S10BP	2101102	9.1	1	254	435	54	45.2	—	58	257	—	—	—	60.5	38.1	—	21.3
C10S12BP	2101104	9.1	1	305	483	54	45.2	—	58	308	—	—	—	60.5	38.1	—	25.9
C10S14BP	2101106	9.1	1	356	536	54	45.2	—	58	359	—	—	—	60.5	38.1	—	29
C10D6BP	2101110	9.1	2	152	399	54	97	22.4	109	155	16	17.5	21.3	54	38.1	51.5	18.6
C10D8BP	2101112	9.1	2	203	443	54	97	22.4	109	206	16	17.5	21.3	54	38.1	51.5	26.3
C10D10BP	2101114	9.1	2	254	494	54	97	22.4	109	257	16	17.5	21.3	54	38.1	51.5	37
C10D12BP	2101116	9.1	2	305	541	54	97	22.4	109	308	16	17.5	21.3	54	38.1	51.5	45
C10D14BP	2101118	9.1	2	356	595	54	97	22.4	109	359	16	17.5	21.3	54	38.1	51.5	52
C10T8BP	2101120	9.1	3	203	443	54	148	22.4	161	206	16	17.5	21.3	54	38.1	51.5	36.7
C10T10BP	2101122	9.1	3	254	494	54	148	22.4	161	257	16	17.5	21.3	54	38.1	51.5	52
C10T12BP	2101124	9.1	3	305	541	54	148	22.4	161	308	16	17.5	21.3	54	38.1	51.5	53
C10T14BP	2101126	9.1	3	356	595	54	148	22.4	161	359	16	17.5	21.3	54	38.1	51.5	74
C10Q8BP	2101130	9.1	4	203	443	54	200	22.4	213	206	16	17.5	21.3	54	38.1	51.5	47
C10Q10B	2101132	9.1	4	254	494	54	200	22.4	212.6	257	16	17.5	21.3	54	38.1	51.5	68
<b>13.6 Tonnes</b>																	
C15S10B	2101170	13.6	1	254	487	73	52	—	77	257	—	—	—	79	51	—	34.5
C15S12BP	2101172	13.6	1	305	535	73	52	—	77	308	—	—	—	79	51	—	41.7
C15S14SP	2101174	13.6	1	356	586	73	52	—	77	359	—	—	—	79	51	—	50
C15D10BP	2101180	13.6	2	254	564	73	110	31.8	136	257	19.1	20.6	25.4	71.5	51	58.5	52
C15D12BP	2101182	13.6	2	305	611	73	110	31.8	136	308	19.1	20.6	25.4	71.5	51	58.5	63
C15D14BP	2101184	13.6	2	356	662	73	110	31.8	136	359	19.1	20.6	25.4	71.5	51	58.5	76
C15T8BP	2101190	13.6	3	203	513	73	169	31.8	194	206	19.1	20.6	25.4	71.5	51	58.5	47.6
C15T10BP	2101192	13.6	3	254	564	73	169	31.8	194	257	19.1	20.6	25.4	71.5	51	58.5	69
C15T12BP	2101194	13.6	3	305	611	73	169	31.8	194	308	19.1	20.6	25.4	71.5	51	58.5	82
C15T14BP	2101196	13.6	3	356	662	73	169	31.8	194	359	19.1	20.6	25.4	71.5	51	58.5	97
C15Q10BP	2101200	13.6	4	254	564	73	227	31.8	252	257	19.1	20.6	25.4	71.5	51	58.5	95
<b>18.1 Tonnes</b>																	
C20S18BP	2101244	18.1	1	457	708	76	64.5	19.1	103	460	—	—	—	79	51	—	92
C20D12BP	2101250	18.1	2	305	703	76	110	19.1	148	308	22.4	24.6	29	71.5	51	58.5	75
C20D14BP	2101252	18.1	2	356	724	76	110	19.1	148	359	22.4	24.6	29	71.5	51	58.5	90



## 680 Blocks –“P” Fitting – Blocks with Bolt Only – See Drawing on Page 339

Model No.	680-P Inquiry Stock No.	Working Load Limit (t)	No. of Sheaves	Sheave Diam. (mm)	Dimensions (mm)												Weight Each (kg)
					A	B	C	D	E	F	G	H	I	J	K	X	
C20D16BP	2101254	18.1	2	406	781	76	110	19.1	148	409	22.4	24.6	29	71.5	51	58.5	108
C20T10BP	2101260	18.1	3	254	629	76	169	19.1	207	257	22.4	24.6	29	71.5	51	58.5	81
C20T12BP	2101262	18.1	3	305	678	76	169	19.1	207	308	22.4	24.6	29	71.5	51	58.5	94
C20T14BP	2101264	18.1	3	356	724	76	169	19.1	207	359	22.4	24.6	29	71.5	51	58.5	116
C20T16BP	2101266	18.1	3	406	781	76	169	19.1	207	409	22.4	24.6	29	71.5	51	58.5	140
C20Q8BP	2101270	18.1	4	203	573	76	227	19.1	265	206	22.4	24.6	29	71.5	51	58.5	78
C20Q10BP	2101272	18.1	4	254	629	76	227	19.1	265	257	22.4	24.6	29	71.5	51	58.5	99
C20Q12BP	2101274	18.1	4	305	678	76	227	19.1	265	308	22.4	24.6	29	71.5	51	58.5	119
C20Q14BP	2101276	18.1	4	356	724	76	227	19.1	265	359	22.4	24.6	29	71.5	51	58.5	142
<b>22.7 Tonnes</b>																	
C25S18BP	2101314	22.7	1	457	708	76	64.5	12.7	103	460	—	—	—	79	51	—	92
C25D12BP	2101320	22.7	2	305	703	76	110	12.7	148	308	22.4	24.6	29	71.5	51	58.5	76
C25D14BP	2101322	22.7	2	356	724	76	110	12.7	148	359	22.4	24.6	29	71.5	51	58.5	90
C25D16BP	2101324	22.7	2	406	781	76	110	12.7	148	409	22.4	24.6	29	71.5	51	58.5	108
C25T10BP	2101330	22.7	3	254	629	76	169	12.7	207	257	22.4	24.6	29	71.5	51	58.5	81
C25T12BP	2101332	22.7	3	305	678	76	169	12.7	207	308	22.4	24.6	29	71.5	51	58.5	94
C25T14BP	2101334	22.7	3	356	724	76	169	12.7	207	359	22.4	24.6	29	71.5	51	58.5	115
C25T16BP	2101336	22.7	3	406	781	76	169	12.7	207	409	22.4	24.6	29	71.5	51	58.5	140
C25Q08BP	2101340	22.7	4	203	573	76	227	12.7	265	206	22.4	24.6	29	71.5	51	58.5	76
C25Q10BP	2101342	22.7	4	254	629	76	227	12.7	265	257	22.4	24.6	29	71.5	51	58.5	101
C25Q12BP	2101344	22.7	4	305	678	76	227	12.7	265	308	22.4	24.6	29	71.5	51	58.5	119
C25Q14BP	2101346	22.7	4	356	724	76	227	12.7	265	359	22.4	24.6	29	71.5	51	58.5	142
<b>27.2 Tonnes</b>																	
C30D12BP	2101390	27.2	2	305	765	108	136	52.3	174	308	25.4	26.9	34	107	76	71	86
C30D14BP	2101392	27.2	2	356	813	108	136	52.3	174	359	25.4	26.9	34	107	76	71	103
C30D16BP	2101394	27.2	2	406	873	108	136	52.3	174	409	25.4	26.9	34	107	76	71	121
C30D18BP	2101396	27.2	2	457	917	108	136	52.3	174	460	25.4	26.9	34	107	76	71	156
C30T10BP	2101400	27.2	3	254	718	108	169	52.3	207	257	25.4	26.9	34	107	76	58.5	97
C30T12BP	2101402	27.2	3	305	765	108	169	52.3	207	308	25.4	26.9	34	107	76	58.5	108
C30T14BP	2101404	27.2	3	356	813	108	169	52.3	207	359	25.4	26.9	34	107	76	58.5	128
C30T16BP	2101406	27.2	3	406	873	108	169	52.3	207	409	25.4	26.9	34	107	76	58.5	156
C30Q10BP	2101410	27.2	4	254	917	108	227	52.3	265	257	25.4	26.9	34	107	76	58.5	116
C30Q12BP	2101412	27.2	4	305	765	108	227	52.3	265	308	25.4	26.9	34	107	76	58.5	132
C30Q14BP	2101414	27.2	4	356	813	108	227	52.3	265	359	25.4	26.9	34	107	76	58.5	155
C30Q16BP	2101416	27.2	4	406	873	108	227	52.3	265	409	25.4	26.9	34	107	76	58.5	189
<b>31.8 Tonnes</b>																	
C35D12BP	2101450	31.8	2	305	765	108	136	42.9	174	308	25.4	26.9	34	107	76	71	86
C35D14BP	2101452	31.8	2	356	813	108	136	42.9	174	359	25.4	26.9	34	107	76	71	102
C35D16BP	2101454	31.8	2	406	873	108	136	42.9	174	409	25.4	26.9	34	107	76	71	121
C35D18BP	2101456	31.8	2	457	917	108	136	42.9	174	460	25.4	26.9	34	107	76	71	156
C35T10BP	2101460	31.8	3	254	718	108	169	42.9	207	257	25.4	26.9	34	107	76	58.5	97
C35T12BP	2101462	31.8	3	305	765	108	169	42.9	207	308	25.4	26.9	34	107	76	58.5	108
C35T14BP	2101464	31.8	3	356	813	108	169	42.9	207	359	25.4	26.9	34	107	76	58.5	128
C35T16BP	2101466	31.8	3	406	873	108	169	42.9	207	409	25.4	26.9	34	107	76	58.5	156
C35Q10BP	2101470	31.8	4	254	917	108	227	42.9	265	257	25.4	26.9	34	107	76	58.5	116
C35Q12BP	2101472	31.8	4	305	765	108	227	42.9	265	308	25.4	26.9	34	107	76	58.5	132
C35Q14BP	2101474	31.8	4	356	813	108	227	42.9	265	359	25.4	26.9	34	107	76	58.5	155
C35Q16BP	2101476	31.8	4	406	873	108	227	42.9	265	409	25.4	26.9	34	107	76	58.5	189
<b>36.3 Tonnes</b>																	
C40D18BP	2101512	36.3	2	457	940	108	148	31.8	199	460	28.7	31.8	37.1	107	76	84	217
C40D20BP	2101514	36.3	2	508	972	108	148	31.8	199	511	28.7	31.8	37.1	107	76	84	257
C40D24BP	2101516	36.3	2	610	1073	108	148	31.8	199	613	28.7	31.8	37.1	107	76	84	338
C40T14BP	2101520	36.3	3	356	870	127	169	31.8	207	359	28.7	31.8	37.1	107	76	58.5	136
C40T16BP	2101522	36.3	3	406	927	127	169	31.8	207	409	28.7	31.8	37.1	107	76	58.5	163
C40T18BP	2101524	36.3	3	457	940	108	213	31.8	264	460	28.7	31.8	37.1	107	76	73.5	264
C40T20BP	2101526	36.3	3	508	972	108	213	31.8	264	511	28.7	31.8	37.1	107	76	73.5	313
C40Q12BP	2101530	36.3	4	305	822	127	227	31.8	265	308	28.7	31.8	37.1	107	76	58.5	144
C40Q14BP	2101532	36.3	4	356	870	127	227	31.8	265	359	28.7	31.8	37.1	107	76	58.5	164
C40Q16BP	2101534	36.3	4	406	927	127	227	31.8	265	409	28.7	31.8	37.1	107	76	58.5	195
C40Q18BP	2101536	36.3	4	457	940	108	288	31.8	339	460	28.7	31.8	37.1	107	76	73.5	310
<b>40.8 Tonnes</b>																	
C45D18BP	2101582	40.8	2	457	940	108	148	25.4	199	460	28.7	31.8	37.1	107	76	84	217
C45D20BP	2101584	40.8	2	508	972	108	148	25.4	199	511	28.7	31.8	37.1	107	76	84	257
C45D24BP	2101586	40.8	2	610	1073	108	148	25.4	199	613	28.7	31.8	37.1	107	76	84	338
C45T14BP	2101590	40.8	3	356	870	127	169	25.4	207	359	28.7	31.8	37.1	107	76	58.5	136
C45T16BP	2101592	40.8	3	406	927	127	169	25.4	207	409	28.7	31.8	37.1	107	76	58.5	163
C45T18BP	2101594	40.8	3	457	940	108	213	25.4	264	460	28.7	31.8	37.1	107	76	73.5	264
C45T20BP	2101596	40.8	3	508	972	108	213	25.4	264	511	28.7	31.8	37.1	107	76	73.5	313
C45Q12BP	2101600	40.8	4	305	822	127	227	25.4	265	308	28.7	31.8	37.1	107	76	58.5	144
C45Q14BP	2101602	40.8	4	356	870	127	227	25.4	265	359	28.7	31.8	37.1	107	76	58.5	164
C45Q16BP	2101604	40.8	4	406	927	127	227	25.4	265	409	28.7	31.8	37.1	107	76	58.5	195

680 Blocks –“P” Fitting – Blocks with Bolt Only – See Drawing on Page 339

Model No.	680-P Inquiry Stock No.	Working Load Limit (t)	No. of Sheaves	Sheave Diam. (mm)	Dimensions (mm)											Weight Each (kg)	
					A	B	C	D	E	F	G	H	I	J	K		X
C45Q18BP	2101606	40.8	4	457	940	108	288	25.4	339	460	28.7	31.8	37.1	107	76	73.5	310
<b>45.4 Tonnes</b>																	
C50D20BP	2101640	45.4	2	508	1067	140	148	44.5	199	511	31.8	35.1	41.1	124	89	84	279
C50D24BP	2101642	45.4	2	610	1168	140	148	44.5	199	613	31.8	35.1	41.1	124	89	84	362
C50T18BP	2101650	45.4	3	457	1035	140	213	44.5	264	460	31.8	35.1	41.1	124	89	73.5	271
C50T20BP	2101652	45.4	3	508	1067	140	213	44.5	264	511	31.8	35.1	41.1	124	89	73.5	322
C50T24BP	2101654	45.4	3	610	1168	140	213	44.5	264	613	31.8	35.1	41.1	124	89	73.5	419
C50Q16BP	2101660	45.4	4	406	981	140	288	44.5	339	409	31.8	35.1	41.1	124	89	73.5	271
C50Q18BP	2101662	45.4	4	457	1035	140	288	44.5	339	460	31.8	35.1	41.1	124	89	73.5	339
<b>49.9 Tonnes</b>																	
C55D20BP	2101700	49.9	2	508	1067	140	148	39.6	199	511	31.8	35.1	41.1	124	89	84	279
C55D24BP	2101702	49.9	2	610	1168	140	148	39.6	199	613	31.8	35.1	41.1	124	89	84	362
C55T18BP	2101710	49.9	3	457	1035	140	213	39.6	264	460	31.8	35.1	41.1	124	89	73.5	271
C55T20BP	2101712	49.9	3	508	1067	140	213	39.6	264	511	31.8	35.1	41.1	124	89	73.5	322
C55T24BP	2101714	49.9	3	610	1168	140	213	39.6	264	613	31.8	35.1	41.1	124	89	73.5	419
C55Q16BP	2101720	49.9	4	406	981	140	288	39.6	339	409	31.8	35.1	41.1	124	89	73.5	271
C55Q18BP	2101722	49.9	4	457	1035	140	288	39.6	339	460	31.8	35.1	41.1	124	89	73.5	339
<b>54.4 Tonnes</b>																	
C60T18BP	2101760	54.4	3	457	1035	140	213	35.1	264	460	31.8	35.1	41.1	124	89	73.5	271
C60T20BP	2101762	54.4	3	508	1067	140	213	35.1	264	511	31.8	35.1	41.1	124	89	73.5	322
C60T24BP	2101764	54.4	3	610	1168	140	213	35.1	264	613	31.8	35.1	41.1	124	89	73.5	419
C60Q18BP	2101770	54.4	4	457	1035	140	288	35.1	339	460	31.8	35.1	41.1	124	89	73.5	339
C60Q20BP	2101772	54.4	4	508	1067	140	288	35.1	339	511	31.8	35.1	41.1	124	89	73.5	407
C60Q24BP	2101774	54.4	4	610	1168	140	288	35.1	339	613	31.8	35.1	41.1	124	89	73.5	503
<b>59 Tonnes</b>																	
C65T18BP	2101810	59	3	457	1035	140	213	30.2	264	460	31.8	35.1	41.1	124	89	73.5	271
C65T20BP	2101812	59	3	508	1067	140	213	30.2	264	511	31.8	35.1	41.1	124	89	73.5	322
C65T24BP	2101814	59	3	610	1168	140	213	30.2	264	613	31.8	35.1	41.1	124	89	73.5	419
C65Q18BP	2101820	59	4	457	1035	140	288	30.2	339	460	31.8	35.1	41.1	124	89	73.5	339
C65Q20BP	2101822	59	4	508	1067	140	288	30.2	339	511	31.8	35.1	41.1	124	89	73.5	407
C65Q24BP	2101824	59	4	610	1168	140	288	30.2	339	613	31.8	35.1	41.1	124	89	73.5	503
<b>63 Tonnes</b>																	
C70T20BP	2101830	63	3	508	1175	178	232	44.5	283	511	35.1	38.1	46.2	142	102	3.3	404
C70Q20BP	2101840	63	4	508	1175	178	287	44.5	338	511	35.1	38.1	46.2	142	102	2.9	424
C70Q24BP	2101842	63	4	610	1276	178	287	44.5	338	613	35.1	38.1	46.2	142	102	2.9	572
C70QN20BP	2101850	63	5	508	1175	178	232	44.5	463	511	35.1	38.1	46.2	142	102	3.3	592
C70QN24BP	2101852	63	5	610	1276	178	232	44.5	463	613	35.1	38.1	46.2	142	102	3.3	778
<b>72 Tonnes</b>																	
C80T20BP	2101860	72	3	508	1175	178	232	36.6	283	511	35.1	38.1	46.2	142	102	3.3	404
C80Q20BP	2101870	72	4	508	1175	178	287	36.6	338	511	35.1	38.1	46.2	142	102	2.9	454
C80Q24BP	2101872	72	4	610	1276	178	287	36.6	338	613	35.1	38.1	46.2	142	102	2.9	572
C80QN20BP	2101880	72	5	508	1175	178	232	36.6	463	511	35.1	38.1	46.2	142	102	3.3	592
C80QN24BP	2101882	72	5	610	1276	178	232	36.6	463	613	35.1	38.1	46.2	142	102	3.3	778
<b>81 Tonnes</b>																	
C90Q20BP	2101920	81	4	508	1175	191	287	30.2	338	511	35.1	38.1	46.2	142	102	2.9	481
C90Q24BP	2101922	81	4	610	1276	191	287	30.2	338	613	35.1	38.1	46.2	142	102	2.9	644
C90QN20BP	2101930	81	5	508	1175	191	232	30.2	463	511	35.1	38.1	46.2	142	102	3.3	592
C90QN24BP	2101932	81	5	610	1276	191	232	30.2	463	613	35.1	38.1	46.2	142	102	3.3	805
<b>90 Tonnes</b>																	
C100QN20BP	2101970	90	5	508	1175	191	232	25.4	463	511	35.1	38.1	46.2	142	102	3.3	592
C100QN24BP	2101972	90	5	610	1276	191	232	25.4	463	613	35.1	38.1	46.2	142	102	3.3	805
C100SX20BP	2101980	90	6	508	1175	191	287	25.4	518	511	35.1	38.1	46.2	142	102	2.9	619
C100SX24BP	2101982	90	6	610	1276	191	287	25.4	518	613	35.1	38.1	46.2	142	102	2.9	841





## 680 BLOCKS – “H” FITTING

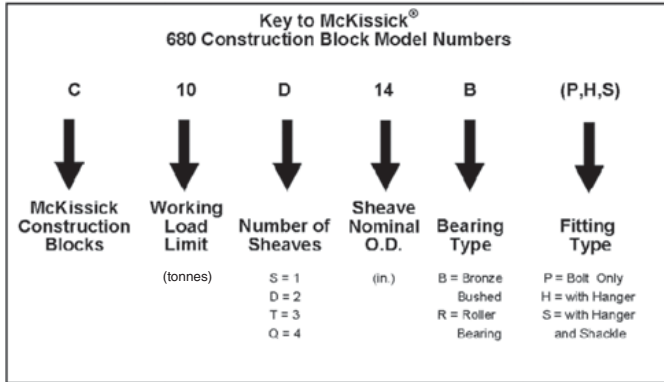

Sheave Diameter (in.)	WireLine Size (in.)									
	3/8	7/16	1/2	9/16	5/8	3/4	7/8	1	1-1/8	1-1/4
6										
8										
10										
12										
14										
16										
18										
20										
24										



All sizes are RFID EQUIPPED.

### 680 Blocks –“H” Fitting – Blocks with Hanger – See Drawing on Page 339

Model No.	680-H Inquiry Stock No.	Working Load Limit (t)	No. of Sheaves	Sheave Diam. (mm)	Dimensions (mm)													Weight Each (kg)
					A	E	F	G	H	I	L	M	N	O	P	Q	X	
<b>4.5 Tonnes</b>																		
C5S6BH	2102000	4.5	1	152	381	58	155	—	—	—	41.4	31.8	26.9	29.5	82.5	47.2	—	10
C5S8BH	2102002	4.5	1	203	429	58	206	—	—	—	41.4	31.8	26.9	29.5	82.5	47.2	—	15.4
C5D6BH	2102010	4.5	2	152	448	109	155	16	17.5	21.3	41.4	31.8	26.9	29.5	82.5	57	51.5	16.8
C5D8BH	2102012	4.5	2	203	495	109	206	16	17.5	21.3	41.4	31.8	26.9	29.5	82.5	57	51.5	26.3
C5T6BH	2102020	4.5	3	152	448	161	155	16	17.5	21.3	41.4	31.8	26.9	29.5	82.5	57	51.5	23.1
C5T8BH	2102022	4.5	3	203	495	161	206	16	17.5	21.3	41.4	31.8	26.9	29.5	82.5	57	51.5	36.7
<b>6.8 Tonnes</b>																		
C7S6BH	2102050	6.8	1	152	381	58	155	—	—	—	41.4	31.8	26.9	29.5	82.5	47.2	—	10
C7S8BH	2102052	6.8	1	203	429	58	206	—	—	—	41.4	31.8	26.9	29.5	82.5	47.2	—	15.4
C7D6BH	2102060	6.8	2	152	448	109	155	16	17.5	21.3	41.4	31.8	26.9	29.5	82.5	57	51.5	16.8
C7D8BH	2102062	6.8	2	203	495	109	206	16	17.5	21.3	41.4	31.8	26.9	29.5	82.5	57	51.5	26.3
C7T6BH	2102070	6.8	3	152	448	161	155	16	17.5	21.3	41.4	31.8	26.9	29.5	82.5	57	51.5	23.1
C7T8BH	2102072	6.8	3	203	495	161	206	16	17.5	21.3	41.4	31.8	26.9	29.5	82.5	57	51.5	36.7
<b>9.1 Tonnes</b>																		
C10S8BH	2102100	9.1	1	203	467	58	206	—	—	—	47.8	35.1	33.3	42.9	102	53	—	17.7
C10S10BH	2102102	9.1	1	254	518	58	257	—	—	—	47.8	35.1	33.3	42.9	102	53	—	23.6
C10S12BH	2102104	9.1	1	305	565	58	308	—	—	—	47.8	35.1	33.3	42.9	102	53	—	28.1
C10S14BH	2102106	9.1	1	356	619	58	359	—	—	—	47.8	35.1	33.3	42.9	102	53	—	31.3
C10D6BH	2102110	9.1	2	152	481	109	155	16	17.5	21.3	47.8	35.1	33.3	42.9	102	68	51.5	20
C10D8BH	2102112	9.1	2	203	526	109	206	16	17.5	21.3	47.8	35.1	33.3	42.9	102	68	51.5	29.5
C10D10BH	2102114	9.1	2	254	576	109	257	16	17.5	21.3	47.8	35.1	33.3	42.9	102	68	51.5	40.4
C10D12BH	2102116	9.1	2	305	624	109	308	16	17.5	21.3	47.8	35.1	33.3	42.9	102	68	51.5	48.1
C10D14BH	2102118	9.1	2	356	678	109	359	16	17.5	21.3	47.8	35.1	33.3	42.9	102	68	51.5	55
C10T8BH	2102120	9.1	3	203	526	161	206	16	17.5	21.3	47.8	35.1	33.3	42.9	102	88	51.5	40.8
C10T10BH	2102122	9.1	3	254	576	161	257	16	17.5	21.3	47.8	35.1	33.3	42.9	102	88	51.5	56
C10T12BH	2102124	9.1	3	305	624	161	308	16	17.5	21.3	47.8	35.1	33.3	42.9	102	88	51.5	67
C10T14BH	2102126	9.1	3	356	678	161	359	16	17.5	21.3	47.8	35.1	33.3	42.9	102	88	51.5	78
C10Q8BH	2102130	9.1	4	203	526	213	206	16	17.5	21.3	47.8	35.1	33.3	42.9	102	92	51.5	52
C10Q10BH	2102132	9.1	4	254	576	213	257	16	17.5	21.3	47.8	35.1	33.3	42.9	102	92	51.5	73
<b>13.6 Tonnes</b>																		
C15S10BH	2102170	13.6	1	254	602	77	257	—	—	—	66.5	47.8	39.6	54	140	71.5	—	39
C15S12BH	2102172	13.6	1	305	649	77	308	—	—	—	66.5	47.8	39.6	54	140	71.5	—	46.3
C15S14BH	2102174	13.6	1	356	700	77	359	—	—	—	66.5	47.8	39.6	54	140	71.5	—	55
C15D10BH	2102180	13.6	2	254	678	136	257	19.1	20.6	25.4	66.5	47.8	39.6	54	140	86.5	58.5	59
C15D12BH	2102182	13.6	2	305	725	136	308	19.1	20.6	25.4	66.5	47.8	39.6	54	140	86.5	58.5	70
C15D14BH	2102184	13.6	2	356	776	136	359	19.1	20.6	25.4	66.5	47.8	39.6	54	140	86.5	58.5	83
C15T8BH	2102190	13.6	3	203	627	194	206	19.1	20.6	25.4	66.5	47.8	39.6	54	140	98.5	58.5	58
C15T10BH	2102192	13.6	3	254	678	194	257	19.1	20.6	25.4	66.5	47.8	39.6	54	140	98.5	58.5	79
C15T12BH	2102194	13.6	3	305	725	194	308	19.1	20.6	25.4	66.5	47.8	39.6	54	140	98.5	58.5	93
C15T14BH	2102196	13.6	3	356	776	194	359	19.1	20.6	25.4	66.5	47.8	39.6	54	140	98.5	58.5	107
C15Q10BH	2102200	13.6	4	254	678	252	257	19.1	20.6	25.4	66.5	47.8	39.6	54	140	98.5	58.5	98
<b>18.1 Tonnes</b>																		
C20S18BH	2102244	18.1	1	457	819	103	460	—	—	—	63.5	47.8	42.9	54	140	71	-	98
C20D12BH	2102250	18.1	2	305	814	148	308	22.4	24.6	29	63.5	47.8	42.9	54	140	84	58.5	83

680 Blocks – “H” Fitting – Blocks with Hanger – See Drawing on Page 339

Model No.	680-H Inquiry Stock No.	Working Load Limit (t)	No. of Sheaves	Sheave Diam. (mm)	Dimensions (mm)														Weight Each (kg)
					A	E	F	G	H	I	L	M	N	O	P	Q	X		
C20D14BH	2102252	18.1	2	356	835	148	359	22.4	24.6	29	63.5	47.8	42.9	54	140	84	58.5	97	
C20D16BH	2102254	18.1	2	406	893	148	409	22.4	24.6	29	63.5	47.8	42.9	54	140	84	58.5	115	
C20T10BH	2102260	18.1	3	254	740	207	257	22.4	24.6	29	63.5	47.8	42.9	54	140	98.5	58.5	91	
C20T12BH	2102262	18.1	3	305	789	207	308	22.4	24.6	29	63.5	47.8	42.9	54	140	98.5	58.5	104	
C20T14BH	2102264	18.1	3	356	835	207	359	22.4	24.6	29	63.5	47.8	42.9	54	140	98.5	58.5	125	
C20T16BH	2102266	18.1	3	406	892	207	409	22.4	24.6	29	63.5	47.8	42.9	54	140	98.5	58.5	149	
C20Q8BH	2102270	18.1	4	203	684	265	206	22.4	24.6	29	63.5	47.8	42.9	54	140	98.5	58.5	89	
C20Q10BH	2102272	18.1	4	254	740	265	257	22.4	24.6	29	63.5	47.8	42.9	54	140	98.5	58.5	112	
C20Q12BH	2102274	18.1	4	305	789	265	308	22.4	24.6	29	63.5	47.8	42.9	54	140	98.5	58.5	130	
C20Q14BH	2102276	18.1	4	356	835	265	359	22.4	24.6	29	63.5	47.8	42.9	54	140	98.5	58.5	153	
<b>22.7 Tonnes</b>																			
C25S18BH	2102314	22.7	1	457	819	103	460	-	-	-	63.5	47.8	42.9	54	140	71	—	98	
C25D12BH	2102320	22.7	2	305	814	148	308	22.4	24.6	29	63.5	47.8	42.9	54	140	84	58.5	83	
C25D14BH	2102322	22.7	2	356	835	148	359	22.4	24.6	29	63.5	47.8	42.9	54	140	84	58.5	97	
C25D16BH	2102324	22.7	2	406	893	148	409	22.4	24.6	29	63.5	47.8	42.9	54	140	84	58.5	115	
C25T10BH	2102330	22.7	3	254	740	207	257	22.4	24.6	29	63.5	47.8	42.9	54	140	98.5	58.5	91	
C25T12BH	2102332	22.7	3	305	789	207	308	22.4	24.6	29	63.5	47.8	42.9	54	140	98.5	58.5	104	
C25T14BH	2102334	22.7	3	356	835	207	359	22.4	24.6	29	63.5	47.8	42.9	54	140	98.5	58.5	125	
C25T16BH	2102336	22.7	3	406	892	207	409	22.4	24.6	29	63.5	47.8	42.9	54	140	98.5	58.5	149	
C25Q8BH	2102340	22.7	4	203	684	265	206	22.4	24.6	29	63.5	47.8	42.9	54	140	98.5	58.5	89	
C25Q10BH	2102342	22.7	4	254	740	265	257	22.4	24.6	29	63.5	47.8	42.9	54	140	98.5	58.5	112	
C25Q12BH	2102344	22.7	4	305	789	265	308	22.4	24.6	29	63.5	47.8	42.9	54	140	98.5	58.5	130	
C25Q14BH	2102346	22.7	4	356	835	265	359	22.4	24.6	29	63.5	47.8	42.9	54	140	98.5	58.5	153	
<b>27.2 Tonnes</b>																			
C30D12BH	2102390	27.2	2	305	899	174	308	25.4	26.9	34	70	63.5	42.9	57	178	97.5	71	102	
C30D14BH	2102392	27.2	2	356	946	174	359	25.4	26.9	34	70	63.5	42.9	57	178	97.5	71	118	
C30D16BH	2102394	27.2	2	406	1006	174	409	25.4	26.9	34	70	63.5	42.9	57	178	97.5	71	137	
C30D18BH	2102396	27.2	2	457	1051	174	460	25.4	26.9	34	70	63.5	42.9	57	178	97.5	71	172	
C30T10BH	2102400	27.2	3	254	851	207	257	25.4	26.9	34	70	63.5	42.9	57	178	108	58.5	115	
C30T12BH	2102402	27.2	3	305	899	207	308	25.4	26.9	34	70	63.5	42.9	57	178	108	58.5	127	
C30T14BH	2102404	27.2	3	356	946	207	359	25.4	26.9	34	70	63.5	42.9	57	178	108	58.5	146	
C30T16BH	2102406	27.2	3	406	1006	207	409	25.4	26.9	34	70	63.5	42.9	57	178	108	58.5	174	
C30Q10BH	2102410	27.2	4	254	1051	265	257	25.4	26.9	34	70	63.5	42.9	57	178	108	58.5	139	
C30Q12BH	2102412	27.2	4	305	899	265	308	25.4	26.9	34	70	63.5	42.9	57	178	108	58.5	155	
C30Q14BH	2102414	27.2	4	356	946	265	359	25.4	26.9	34	70	63.5	42.9	57	178	108	58.5	178	
C30Q16BH	2102416	27.2	4	406	1006	265	409	25.4	26.9	34	70	63.5	42.9	57	178	108	58.5	213	
<b>31.8 Tonnes</b>																			
C35D12BH	2102450	31.8	2	305	899	174	308	25.4	26.9	34	70	63.5	42.9	57	178	97.5	71	102	
C35D14BH	2102452	31.8	2	356	946	174	359	25.4	26.9	34	70	63.5	42.9	57	178	97.5	71	118	
C35D16BH	2102454	31.8	2	406	1006	174	409	25.4	26.9	34	70	63.5	42.9	57	178	97.5	71	137	
C35D18BH	2102456	31.8	2	457	1051	174	460	25.4	26.9	34	70	63.5	42.9	57	178	97.5	71	172	
C35T10BH	2102460	31.8	3	254	851	207	257	25.4	26.9	34	70	63.5	42.9	57	178	108	58.5	115	
C35T12BH	2102462	31.8	3	305	899	207	308	25.4	26.9	34	70	63.5	42.9	57	178	108	58.5	127	
C35T14BH	2102464	31.8	3	356	946	207	359	25.4	26.9	34	70	63.5	42.9	57	178	108	58.5	146	
C35T16BH	2102466	31.8	3	406	1006	207	409	25.4	26.9	34	70	63.5	42.9	57	178	108	58.5	174	
C35Q10BH	2102470	31.8	4	254	1051	265	257	25.4	26.9	34	70	63.5	42.9	57	178	108	58.5	139	
C35Q12BH	2102472	31.8	4	305	899	265	308	25.4	26.9	34	70	63.5	42.9	57	178	108	58.5	155	
C35Q14BH	2102474	31.8	4	356	946	265	359	25.4	26.9	34	70	63.5	42.9	57	178	108	58.5	178	
C35Q16BH	2102476	31.8	4	406	1006	265	409	25.4	26.9	34	70	63.5	42.9	57	178	108	58.5	213	
<b>36.3 Tonnes</b>																			
C40D18BH	2102512	36.3	2	457	1089	199	460	28.7	31.8	37.1	76	73	52.5	70	184	106	84	239	
C40D20BH	2102514	36.3	2	508	1121	199	511	28.7	31.8	37.1	76	73	52.5	70	184	106	84	280	
C40D24BH	2102516	36.3	2	610	1222	199	613	28.7	31.8	37.1	76	73	52.5	70	184	106	84	361	
C40T14BH	2102520	36.3	3	356	1019	207	359	28.7	31.8	37.1	76	73	52.5	70	203	114	58.5	161	
C40T16BH	2102522	36.3	3	406	1076	207	409	28.7	31.8	37.1	76	73	52.5	70	203	114	58.5	189	
C40T18BH	2102524	36.3	3	457	1089	264	460	28.7	31.8	37.1	76	73	52.5	70	184	114	73.5	293	
C40T20BH	2102526	36.3	3	508	1121	264	511	28.7	31.8	37.1	76	73	52.5	70	184	114	73.5	343	
C40Q12BH	2102530	36.3	4	305	972	265	308	28.7	31.8	37.1	76	73	52.5	70	203	133	58.5	176	
C40Q14BH	2102532	36.3	4	356	1019	265	359	28.7	31.8	37.1	76	73	52.5	70	203	133	58.5	196	
C40Q16BH	2102534	36.3	4	406	1076	265	409	28.7	31.8	37.1	76	73	52.5	70	203	133	58.5	227	
C40Q18BH	2102536	36.3	4	457	1089	339	460	28.7	31.8	37.1	76	73	52.5	70	184	114	73.5	347	
<b>40.8 Tonnes</b>																			
C45D18BH	2102582	40.8	2	457	1089	199	460	28.7	31.8	37.1	76	73	52.5	70	184	106	84	239	
C45D20BH	2102584	40.8	2	508	1121	199	511	28.7	31.8	37.1	76	73	52.5	70	184	106	84	280	
C45D24BH	2102586	40.8	2	610	1222	199	613	28.7	31.8	37.1	76	73	52.5	70	184	106	84	361	
C45T14BH	2102590	40.8	3	356	1019	207	359	28.7	31.8	37.1	76	73	52.5	70	203	114	58.5	161	
C45T16BH	2102592	40.8	3	406	1076	207	409	28.7	31.8	37.1	76	73	52.5	70	203	114	58.5	189	
C45T18BH	2102594	40.8	3	457	1089	264	460	28.7	31.8	37.1	76	73	52.5	70	184	114	73.5	293	
C45T20BH	2102596	40.8	3	508	1121	264	511	28.7	31.8	37.1	76	73	52.5	70	184	114	73.5	343	
C45Q12BH	2102600	40.8	4	305	972	265	308	28.7	31.8	37.1	76	73	52.5	70	203	133	58.5	176	



## 680 Blocks –“H” Fitting – Blocks with Hanger – See Drawing on Page 339

Model No.	680-H Inquiry Stock No.	Working Load Limit (t)	No. of Sheaves	Sheave Diam. (mm)	Dimensions (mm)													Weight Each (kg)
					A	E	F	G	H	I	L	M	N	O	P	Q	X	
C45Q14BH	2102602	40.8	4	356	1019	265	359	28.7	31.8	37.1	76	73	52.5	70	203	133	58.5	196
C45Q16BH	2102604	40.8	4	406	1076	265	409	28.7	31.8	37.1	76	73	52.5	70	203	133	58.5	227
C45Q18BH	2102606	40.8	4	457	1089	339	460	28.7	31.8	37.1	76	73	52.5	70	184	114	73.5	347
<b>45.4 Tonnes</b>																		
C50D20BH	2102640	45.4	2	508	1238	199	511	31.8	35.1	41.1	89	82.5	58.5	76	229	116	84	312
C50D24BH	2102642	45.4	2	610	1340	199	613	31.8	35.1	41.1	89	82.5	58.5	76	229	116	84	395
C50T18BH	2102650	45.4	3	457	1207	264	460	31.8	35.1	41.1	89	82.5	58.5	76	229	139	73.5	318
C50T20BH	2102652	45.4	3	508	1238	264	511	31.8	35.1	41.1	89	82.5	58.5	76	229	139	73.5	368
C50T24BH	2102654	45.4	3	610	1340	264	613	31.8	35.1	41.1	89	82.5	58.5	76	229	139	73.5	465
C50Q16BH	2102660	45.4	4	406	1153	339	409	31.8	35.1	41.1	89	82.5	58.5	76	229	149	73.5	330
C50Q18BH	2102662	45.4	4	457	1207	339	460	31.8	35.1	41.1	89	82.5	58.5	76	229	149	73.5	398
<b>49.9 Tonnes</b>																		
C55D20BH	2102700	49.9	2	508	1238	199	511	31.8	35.1	41.1	89	82.5	58.5	76	229	116	84	312
C55D24BH	2102702	49.9	2	610	1340	199	613	31.8	35.1	41.1	89	82.5	58.5	76	229	116	84	395
C55T18BH	2102710	49.9	3	457	1207	264	460	31.8	35.1	41.1	89	82.5	58.5	76	229	139	73.5	318
C55T20BH	2102712	49.9	3	508	1238	264	511	31.8	35.1	41.1	89	82.5	58.5	76	229	139	73.5	368
C55T24BH	2102714	49.9	3	610	1340	264	613	31.8	35.1	41.1	89	82.5	58.5	76	229	139	73.5	465
C55Q16BH	2102720	49.9	4	406	1153	339	409	31.8	35.1	41.1	89	82.5	58.5	76	229	149	73.5	330
C55Q18BH	2102722	49.9	4	457	1194	339	460	31.8	35.1	41.1	89	82.5	58.5	76	229	149	73.5	398
<b>54.4 Tonnes</b>																		
C60T18BH	2102760	54.4	3	457	1216	264	460	31.8	35.1	41.1	89	92	58.5	76	229	139	73.5	318
C60T20BH	2102762	54.4	3	508	1248	264	511	31.8	35.1	41.1	89	92	58.5	76	229	139	73.5	368
C60T24BH	2102764	54.4	3	610	1349	264	613	31.8	35.1	41.1	89	92	58.5	76	229	139	73.5	465
C60Q18BH	2102770	54.4	4	457	1216	339	460	31.8	35.1	41.1	89	92	58.5	76	229	149	73.5	398
C60Q20BH	2102772	54.4	4	508	1248	339	511	31.8	35.1	41.1	89	92	58.5	76	229	149	73.5	466
C60Q24BH	2102774	54.4	4	610	1349	339	613	31.8	35.1	41.1	89	92	58.5	76	229	149	73.5	562
<b>59 Tonnes</b>																		
C65T18BH	2102810	59	3	457	1216	264	460	31.8	35.1	41.1	89	92	58.5	76	229	139	73.5	318
C65T20BH	2102812	59	3	508	1248	264	511	31.8	35.1	41.1	89	92	58.5	76	229	139	73.5	368
C65T24BH	2102814	59	3	610	1349	264	613	31.8	35.1	41.1	89	92	58.5	76	229	139	73.5	465
C65Q18BH	2102820	59	4	457	1216	339	460	31.8	35.1	41.1	89	92	58.5	76	229	149	73.5	398
C65Q20BH	2102822	59	4	508	1248	339	511	31.8	35.1	41.1	89	92	58.5	76	229	149	73.5	466
C65Q24BH	2102824	59	4	610	1349	339	613	31.8	35.1	41.1	89	92	58.5	76	229	149	73.5	562
<b>63 Tonnes</b>																		
C70T20BH	2102830	63	3	508	1407	283	511	35.1	38.1	46.2	114	117	71.4	95.3	292	163	83.8	485
C70Q20BH	2102840	63	4	508	1407	338	511	35.1	38.1	46.2	114	117	71.4	95.3	292	184	73.7	515
C70Q24BH	2102842	63	4	610	1508	338	613	35.1	38.1	46.2	114	117	71.4	95.3	292	184	73.7	662
C70QN20BH	2102850	63	5	508	1407	463	511	35.1	38.1	46.2	114	117	71.4	95.3	292	163	83.8	676
C70QN24BH	2102852	63	5	610	1508	463	613	35.1	38.1	46.2	114	117	71.4	95.3	292	163	83.8	862
<b>72 Tonnes</b>																		
C80T20BH	2102860	72	3	508	1407	283	511	35.1	38.1	46.2	114	117	71.4	95.3	292	163	83.8	485
C80Q20BH	2102870	72	4	508	1407	338	511	35.1	38.1	46.2	114	117	71.4	95.3	292	184	73.7	544
C80Q24BH	2102872	72	4	610	1508	338	613	35.1	38.1	46.2	114	117	71.4	95.3	292	184	73.7	662
C80QN20BH	2102880	72	5	508	1407	463	511	35.1	38.1	46.2	114	117	71.4	95.3	292	163	83.8	676
C80QN24BH	2102882	72	5	610	1508	463	613	35.1	38.1	46.2	114	117	71.4	95.3	292	163	83.8	862
<b>81 Tonnes</b>																		
C90Q20BH	2102920	81	4	508	1407	351	511	35.1	38.1	46.2	114	117	71.4	95.3	292	176	73.7	572
C90Q24BH	2102922	81	4	610	1508	351	613	35.1	38.1	46.2	114	117	71.4	95.3	292	176	73.7	735
C90QN20BH	2102930	81	5	508	1407	463	511	35.1	38.1	46.2	114	117	71.4	95.3	292	154	83.8	676
C90QN24BH	2102932	81	5	610	1508	463	613	35.1	38.1	46.2	114	117	71.4	95.3	292	154	83.8	889
<b>90 Tonnes</b>																		
C100QN20BH	2102970	90	5	508	1407	463	511	35.1	38.1	46.2	114	117	71.4	95.3	292	154	83.8	676
C100QN24BH	2102972	90	5	610	1508	463	613	35.1	38.1	46.2	114	117	71.4	95.3	292	154	83.8	889
C100SX20BH	2102980	90	6	508	1407	518	511	35.1	38.1	46.2	114	117	71.4	95.3	292	176	73.7	710
C100SX24BH	2102982	90	6	610	1508	518	613	35.1	38.1	46.2	114	117	71.4	95.3	292	176	73.7	932



680 BLOCKS – “S” FITTING

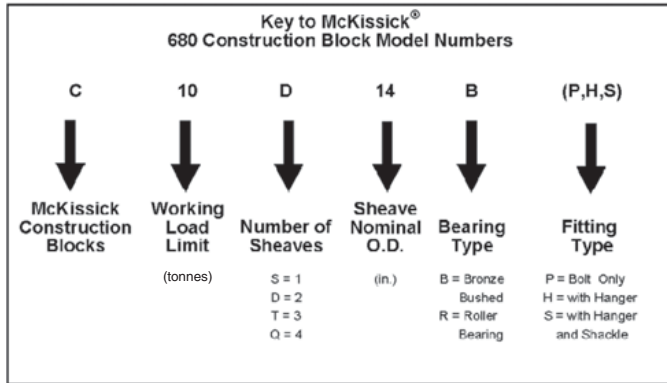

Sheave Diameter (in.)	WireLine Size (in.)									
	3/8	7/16	1/2	9/16	5/8	3/4	7/8	1	1-1/8	1-1/4
6										
8										
10										
12										
14										
16										
18										
20										
24										



All sizes are RFID EQUIPPED.

680 Blocks – “S” Fitting – Blocks with Hanger and Shackle – See Drawing on Page 339

Model No.	680-S Inquiry Stock No.	Working Load Limit (t)	No. of Sheaves	Sheave Diam. (mm)	Dimensions (mm)										Weight Each (kg)		
					A	E	F	G	H	I	S	T	U	V		W	X
<b>4.5 Tonnes</b>																	
C5S6BS	2103000	4.5	1	152	471	58	155	—	—	—	97	65	29	22.4	24.6	—	11.3
C5S8BS	2103002	4.5	1	203	519	58	206	—	—	—	97	65	29	22.4	24.6	—	16.8
C5D6BS	2103010	4.5	2	152	538	109	155	16	17.5	21.3	97	65	29	22.4	24.6	51.5	18.1
C5D8BS	2103012	4.5	2	203	586	109	206	16	17.5	21.3	97	65	29	22.4	24.6	51.5	27.7
C5T6BS	2103020	4.5	3	152	538	161	155	16	17.5	21.3	97	65	29	22.4	24.6	51.5	24.5
C5T8BS	2103022	4.5	3	203	586	161	206	16	17.5	21.3	97	65	29	22.4	24.6	51.5	38.1
<b>6.8 Tonnes</b>																	
C7S6BS	2103050	6.8	1	152	471	58	155	—	—	—	97	65	29	22.4	24.6	—	11.3
C7S8BS	2103052	6.8	1	203	519	58	206	—	—	—	97	65	29	22.4	24.6	—	16.8
C7D6BS	2103060	6.8	2	152	538	109	155	16	17.5	21.3	97	65	29	22.4	24.6	51.5	18.1
C7D8BS	2103062	6.8	2	203	586	109	206	16	17.5	21.3	97	65	29	22.4	24.6	51.5	27.7
C7T6BS	2103070	6.8	3	152	538	161	155	16	17.5	21.3	97	65	29	22.4	24.6	51.5	24.5
C7T8BS	2103072	6.8	3	203	586	161	206	16	17.5	21.3	97	65	29	22.4	24.6	51.5	38.1
<b>9.1 Tonnes</b>																	
C10S8BS	2103100	9.1	1	203	587	58	206	—	—	—	124	89	37.1	28.7	31.8	—	21.3
C10S10BS	2103102	9.1	1	254	638	58	257	—	—	—	124	89	37.1	28.7	31.8	—	27.2
C10S12BS	2103104	9.1	1	305	686	58	308	—	—	—	124	89	37.1	28.7	31.8	—	31.8
C10S14BS	2103106	9.1	1	356	740	58	359	—	—	—	124	89	37.1	28.7	31.8	—	34.9
C10D6BS	2103110	9.1	2	152	602	109	155	16	17.5	21.3	124	89	37.1	28.7	31.8	51.5	23.6
C10D8BS	2103112	9.1	2	203	646	109	206	16	17.5	21.3	124	89	37.1	28.7	31.8	51.5	33.1
C10D10BS	2103114	9.1	2	254	697	109	257	16	17.5	21.3	124	89	37.1	28.7	31.8	51.5	44
C10D12BS	2103116	9.1	2	305	744	109	308	16	17.5	21.3	124	89	37.1	28.7	31.8	51.5	52
C10D14BS	2103118	9.1	2	356	799	109	359	16	17.5	21.3	124	89	37.1	28.7	31.8	51.5	59
C10T8BS	2103120	9.1	3	203	646	161	206	16	17.5	21.3	124	89	37.1	28.7	31.8	51.5	44
C10T10BS	2103122	9.1	3	254	697	161	257	16	17.5	21.3	124	89	37.1	28.7	31.8	51.5	60
C10T12BS	2103124	9.1	3	305	744	161	308	16	17.5	21.3	124	89	37.1	28.7	31.8	51.5	70
C10T14BS	2103126	9.1	3	356	799	161	359	16	17.5	21.3	124	89	37.1	28.7	31.8	51.5	81
C10Q8BS	2103130	9.1	4	203	646	213	206	16	17.5	21.3	124	89	37.1	28.7	31.8	51.5	56
C10Q10BS	2103132	9.1	4	254	697	213	257	16	17.5	21.3	124	89	37.1	28.7	31.8	51.5	77
<b>13.6 Tonnes</b>																	
C15S10BS	2103170	13.6	1	254	744	77	257	—	—	—	152	105	46	35.1	38.1	—	46.3
C15S12BS	2103172	13.6	1	305	792	77	308	—	—	—	152	105	46	35.1	38.1	—	54
C15S14BS	2103174	13.6	1	356	843	77	359	—	—	—	152	105	46	35.1	38.1	—	62
C15D10BS	2103180	13.6	2	254	821	136	257	19.1	20.6	25.4	152	105	46	35.1	38.1	58.5	67
C15D12BS	2103182	13.6	2	305	868	136	308	19.1	20.6	25.4	152	105	46	35.1	38.1	58.5	77
C15D14BS	2103184	13.6	2	356	919	136	359	19.1	20.6	25.4	152	105	46	35.1	38.1	58.5	91
C15T8BS	2103190	13.6	3	203	770	194	206	19.1	20.6	25.4	152	105	46	35.1	38.1	58.5	65
C15T10BS	2103192	13.6	3	254	821	194	257	19.1	20.6	25.4	152	105	46	35.1	38.1	58.5	86
C15T12BS	2103194	13.6	3	305	868	194	308	19.1	20.6	25.4	152	105	46	35.1	38.1	58.5	100
C15T14BS	2103196	13.6	3	356	919	194	359	19.1	20.6	25.4	152	105	46	35.1	38.1	58.5	114
C15Q10BS	2103200	13.6	4	254	821	252	257	19.1	20.6	25.4	152	105	46	35.1	38.1	58.5	105
<b>18.1 Tonnes</b>																	
C20S18BS	2103244	18.1	1	457	979	103	460	—	—	—	167	119	49.3	38.1	41.1	—	107
C20D12BS	2103250	18.1	2	305	975	148	308	22.4	24.6	29	167	119	49.3	38.1	41.1	58.5	92



## 680 Blocks –“S” Fitting – Blocks with Hanger and Shackle – See Drawing on Page 339

Model No.	680-S Inquiry Stock No.	Working Load Limit (t)	No. of Sheaves	Sheave Diam. (mm)	Dimensions (mm)												Weight Each (kg)
					A	E	F	G	H	I	S	T	U	V	W	X	
C20D14BS	2103252	18.1	2	356	995	148	359	22.4	24.6	29	167	119	49.3	38.1	41.1	58.5	107
C20D16BS	2103254	18.1	2	406	1053	148	409	22.4	24.6	29	167	119	49.3	38.1	41.1	58.5	125
C20T10BS	2103260	18.1	3	254	900	207	257	22.4	24.6	29	167	119	49.3	38.1	41.1	58.5	100
C20T12BS	2103262	18.1	3	305	949	207	308	22.4	24.6	29	167	119	49.3	38.1	41.1	58.5	113
C20T14BS	2103264	18.1	3	356	995	207	359	22.4	24.6	29	167	119	49.3	38.1	41.1	58.5	134
C20T16BS	2103266	18.1	3	406	1053	207	409	22.4	24.6	29	167	119	49.3	38.1	41.1	58.5	159
C20Q8BS	2103270	18.1	4	203	845	265	206	22.4	24.6	29	167	119	49.3	38.1	41.1	58.5	98
C20Q10BS	2103272	18.1	4	254	900	265	257	22.4	24.6	29	167	119	49.3	38.1	41.1	58.5	122
C20Q12BS	2103274	18.1	4	305	949	265	308	22.4	24.6	29	167	119	49.3	38.1	41.1	58.5	140
C20Q14BS	2103276	18.1	4	356	995	265	359	22.4	24.6	29	167	119	49.3	38.1	41.1	58.5	162
<b>22.7 Tonnes</b>																	
C25S18BS	2103314	22.7	1	457	979	103	460	—	—	—	167	119	49.3	38.1	41.1	—	107
C25D12BS	2103320	22.7	2	305	975	148	308	22.4	24.6	29	167	119	49.3	38.1	41.1	58.5	92
C25D14BS	2103322	22.7	2	356	995	148	359	22.4	24.6	29	167	119	49.3	38.1	41.1	58.5	107
C25D16BS	2103324	22.7	2	406	1053	148	409	22.4	24.6	29	167	119	49.3	38.1	41.1	58.5	125
C25T10BS	2103330	22.7	3	254	900	207	257	22.4	24.6	29	167	119	49.3	38.1	41.1	58.5	100
C25T12BS	2103332	22.7	3	305	949	207	308	22.4	24.6	29	167	119	49.3	38.1	41.1	58.5	113
C25T14BS	2103334	22.7	3	356	995	207	359	22.4	24.6	29	167	119	49.3	38.1	41.1	58.5	134
C25T16BS	2103336	22.7	3	406	1053	207	409	22.4	24.6	29	167	119	49.3	38.1	41.1	58.5	159
C25Q8BS	2103340	22.7	4	203	845	265	206	22.4	24.6	29	167	119	49.3	38.1	41.1	58.5	98
C25Q10BS	2103342	22.7	4	254	900	265	257	22.4	24.6	29	167	119	49.3	38.1	41.1	58.5	122
C25Q12BS	2103344	22.7	4	305	949	265	308	22.4	24.6	29	167	119	49.3	38.1	41.1	58.5	140
C25Q14BS	2103346	22.7	4	356	995	265	359	22.4	24.6	29	167	119	49.3	38.1	41.1	58.5	162
<b>27.2 Tonnes</b>																	
C30D12BS	2103390	27.2	2	305	1043	174	308	25.4	26.9	34	167	103	49.3	38.1	41.1	71	111
C30D14BS	2103392	27.2	2	356	1091	174	359	25.4	26.9	34	167	103	49.3	38.1	41.1	71	127
C30D16BS	2103394	27.2	2	406	1151	174	409	25.4	26.9	34	167	103	49.3	38.1	41.1	71	147
C30D18BS	2103396	27.2	2	457	1195	174	460	25.4	26.9	34	167	103	49.3	38.1	41.1	71	181
C30T10BS	2103400	27.2	3	254	995	207	257	25.4	26.9	34	167	103	49.3	38.1	41.1	71	124
C30T12BS	2103402	27.2	3	305	1043	207	308	25.4	26.9	34	167	103	49.3	38.1	41.1	71	136
C30T14BS	2103404	27.2	3	356	1091	207	359	25.4	26.9	34	167	103	49.3	38.1	41.1	71	156
C30T16BS	2103406	27.2	3	406	1158	207	409	25.4	26.9	34	167	103	49.3	38.1	41.1	71	184
C30Q10BS	2103410	27.2	4	254	1195	265	257	25.4	26.9	34	167	103	49.3	38.1	41.1	71	148
C30Q12BS	2103412	27.2	4	305	1043	265	308	25.4	26.9	34	167	103	49.3	38.1	41.1	71	165
C30Q14BS	2103414	27.2	4	356	1091	265	359	25.4	26.9	34	167	103	49.3	38.1	41.1	71	188
C30Q16BS	2103416	27.2	4	406	1151	265	409	25.4	26.9	34	167	103	49.3	38.1	41.1	71	177
<b>31.8 Tonnes</b>																	
C35D12BS	2103450	31.8	2	305	1043	174	308	25.4	26.9	34	167	103	49.3	38.1	41.1	71	111
C35D14BS	2103452	31.8	2	356	1091	174	359	25.4	26.9	34	167	103	49.3	38.1	41.1	71	127
C35D16BS	2103454	31.8	2	406	1151	174	409	25.4	26.9	34	167	103	49.3	38.1	41.1	71	147
C35D18BS	2103456	31.8	2	457	1195	174	460	25.4	26.9	34	167	103	49.3	38.1	41.1	71	181
C35T10BS	2103460	31.8	3	254	995	207	257	25.4	26.9	34	167	103	49.3	38.1	41.1	71	124
C35T12BS	2103462	31.8	3	305	1043	207	308	25.4	26.9	34	167	103	49.3	38.1	41.1	71	136
C35T14BS	2103464	31.8	3	356	1091	207	359	25.4	26.9	34	167	103	49.3	38.1	41.1	58.5	156
C35T16BS	2103466	31.8	3	406	1151	207	409	25.4	26.9	34	167	103	49.3	38.1	41.1	58.5	184
C35Q10BS	2103470	31.8	4	254	1195	265	257	25.4	26.9	34	167	103	49.3	38.1	41.1	58.5	148
C35Q12BS	2103472	31.8	4	305	1043	265	308	25.4	26.9	34	167	103	49.3	38.1	41.1	58.5	165
C35Q14BS	2103474	31.8	4	356	1091	265	359	25.4	26.9	34	167	103	49.3	38.1	41.1	58.5	188
C35Q16BS	2103476	31.8	4	406	1151	265	409	25.4	26.9	34	167	103	49.3	38.1	41.1	58.5	222
<b>36.3 Tonnes</b>																	
C40D18BS	2103512	36.3	2	457	1276	199	460	28.7	31.8	37.1	203	130	63.5	44.5	57	84	255
C40D20BS	2103514	36.3	2	508	1308	199	511	28.7	31.8	37.1	203	130	63.5	44.5	57	84	295
C40D24BS	2103516	36.3	2	610	1410	199	613	28.7	31.8	37.1	203	130	63.5	44.5	57	84	376
C40T14BS	2103520	36.3	3	356	1207	207	359	28.7	31.8	37.1	203	130	63.5	44.5	57	58.5	177
C40T16BS	2103522	36.3	3	406	1264	207	409	28.7	31.8	37.1	203	130	63.5	44.5	57	58.5	204
C40T18BS	2103524	36.3	3	457	1276	264	460	28.7	31.8	37.1	203	130	63.5	44.5	57	73.5	308
C40T20BS	2103526	36.3	3	508	1308	264	511	28.7	31.8	37.1	203	130	63.5	44.5	57	73.5	358
C40Q12BS	2103530	36.3	4	305	1159	265	308	28.7	31.8	37.1	203	130	63.5	44.5	57	58.5	191
C40Q14BS	2103532	36.3	4	356	1207	265	359	28.7	31.8	37.1	203	130	63.5	44.5	57	58.5	211
C40Q16BS	2103534	36.3	4	406	1264	265	409	28.7	31.8	37.1	203	130	63.5	44.5	57	58.5	243
C40Q18BS	2103536	36.3	4	457	1276	339	460	28.7	31.8	37.1	203	130	63.5	44.5	57	73.5	363
<b>40.8 Tonnes</b>																	
C45D18BS	2103582	40.8	2	457	1276	199	460	28.7	31.8	37.1	203	130	63.5	44.5	57	84	255
C45D20BS	2103584	40.8	2	508	1308	199	511	28.7	31.8	37.1	203	130	63.5	44.5	57	84	295
C45D24BS	2103586	40.8	2	610	1410	199	613	28.7	31.8	37.1	203	130	63.5	44.5	57	84	376
C45T14BS	2103590	40.8	3	356	1207	207	359	28.7	31.8	37.1	203	130	63.5	44.5	57	58.5	177
C45T16BS	2103592	40.8	3	406	1264	207	409	28.7	31.8	37.1	203	130	63.5	44.5	57	58.5	204
C45T18BS	2103594	40.8	3	457	1276	264	460	28.7	31.8	37.1	203	130	63.5	44.5	57	73.5	308
C45T20BS	2103596	40.8	3	508	1308	264	511	28.7	31.8	37.1	203	130	63.5	44.5	57	73.5	358
C45Q12BS	2103600	40.8	4	305	1159	265	308	28.7	31.8	37.1	203	130	63.5	44.5	57	58.5	191
C45Q14BS	2103602	40.8	4	356	1207	265	359	28.7	31.8	37.1	203	130	63.5	44.5	57	58.5	211

680 Blocks –“S” Fitting – Blocks with Hanger and Shackle – See Drawing on Page 338

Model No.	680-S Inquiry Stock	Working Load Limit	No. of Sheaves	Sheave Diam. (mm)	sDimensions (mm)										Weight Each (kg)		
					A	E	F	G	H	I	S	T	U	V		W	X
C45Q16BS	2103604	40.8	4	406	1264	265	409	28.7	31.8	37.1	203	130	63.5	44.5	57	58.5	243
C45Q18BS	2103606	40.8	4	457	1276	339	460	28.7	31.8	37.1	203	130	63.5	44.5	57	73.5	363
<b>45.4 Tonnes</b>																	
C50D20BS	2103640	45.4	2	508	1443	199	511	31.8	35.1	41.1	226	143	73	51	61	84	336
C50D24BS	2103642	45.4	2	610	1545	199	613	31.8	35.1	41.1	226	143	73	51	61	84	419
C50T18BS	2103650	45.4	3	457	1411	264	460	31.8	35.1	41.1	226	133	73	51	61	73.5	341
C50T20BS	2103652	45.4	3	508	1443	264	511	31.8	35.1	41.1	226	133	73	51	61	73.5	392
C50T24BS	2103654	45.4	3	610	1545	264	613	31.8	35.1	41.1	226	133	73	51	61	73.5	489
C50Q16BS	2103660	45.4	4	406	1357	339	409	31.8	35.1	41.1	226	133	73	51	61	73.5	354
C50Q18BS	2103662	45.4	4	457	1411	339	460	31.8	35.1	41.1	226	133	73	51	61	73.5	422
<b>49.9 Tonnes</b>																	
C55D20BS	2103700	49.9	2	508	1443	199	511	31.8	35.1	41.1	226	143	73	51	61	84	336
C55D24BS	2103702	49.9	2	610	1545	199	613	31.8	35.1	41.1	226	143	73	51	61	84	419
C55T18BS	2103710	49.9	3	457	1411	264	460	31.8	35.1	41.1	226	133	73	51	61	73.5	341
C55T20BS	2103712	49.9	3	508	1443	264	511	31.8	35.1	41.1	226	133	73	51	61	73.5	392
C55T24BS	2103714	49.9	3	610	1545	264	613	31.8	35.1	41.1	226	133	73	51	61	73.5	489
C55Q16BS	2103720	49.9	4	406	1357	339	409	31.8	35.1	41.1	226	133	73	51	61	73.5	354
C55Q18BS	2103722	49.9	4	457	1411	339	460	31.8	35.1	41.1	226	133	73	51	61	73.5	422
<b>54.4 Tonnes</b>																	
C60T18BS	2103760	54.4	3	457	1411	264	460	31.8	35.1	41.1	226	133	73	51	61	73.5	341
C60T20BS	2103762	54.4	3	508	1441	264	511	31.8	35.1	41.1	226	133	73	51	61	73.5	392
C60T24BS	2103764	54.4	3	610	1543	264	613	31.8	35.1	41.1	226	133	73	51	61	73.5	489
C60Q18BS	2103770	54.4	4	457	1411	339	460	31.8	35.1	41.1	226	133	73	51	61	73.5	422
C60Q20BS	2103772	54.4	4	508	1441	339	511	31.8	35.1	41.1	226	133	73	51	61	73.5	490
C60Q24BS	2103774	54.4	4	610	1543	339	613	31.8	35.1	41.1	226	133	73	51	61	73.5	585
<b>59 Tonnes</b>																	
C65T18BS	2103810	59	3	457	1411	264	460	31.8	35.1	41.1	226	133	73	51	61	73.5	341
C65T20BS	2103812	59	3	508	1441	264	511	31.8	35.1	41.1	226	133	73	51	61	73.5	392
C65T24BS	2103814	59	3	610	1543	264	613	31.8	35.1	41.1	226	133	73	51	61	73.5	489
C65Q18BS	2103820	59	4	457	1411	339	460	31.8	35.1	41.1	226	133	73	51	61	73.5	422
C65Q20BS	2103822	59	4	508	1441	339	511	31.8	35.1	41.1	226	133	73	51	61	73.5	490
C65Q24BS	2103824	59	4	610	1543	339	613	31.8	35.1	41.1	226	133	73	51	61	73.5	585
<b>63 Tonnes</b>																	
C70T20BS	2103830	63	3	508	1670	283	511	35.1	38.1	46.2	302	184	91.9	68.8	79.2	83.8	531
C70Q20BS	2103840	63	4	508	1670	338	511	35.1	38.1	46.2	302	184	91.9	68.8	79.2	73.7	560
C70Q24BS	2103842	63	4	610	1772	338	613	35.1	38.1	46.2	302	184	91.9	68.8	79.2	73.7	708
C70QN20BS	2103850	63	5	508	1670	463	511	35.1	38.1	46.2	302	184	91.9	68.8	79.2	83.8	721
C70QN24BS	2103852	63	5	610	1772	463	613	35.1	38.1	46.2	302	184	91.9	68.8	79.2	83.8	907
<b>72 Tonnes</b>																	
C80T20BS	2103860	72	3	508	1670	283	511	35.1	38.1	46.2	302	184	91.9	68.8	79.2	83.8	531
C80Q20BS	2103870	72	4	508	1670	338	511	35.1	38.1	46.2	302	184	91.9	68.8	79.2	73.7	590
C80Q24BS	2103872	72	4	610	1772	338	613	35.1	38.1	46.2	302	184	91.9	68.8	79.2	73.7	708
C80QN20BS	2103880	72	5	508	1670	463	511	35.1	38.1	46.2	302	184	91.9	68.8	79.2	83.8	721
C80QN24BS	2103882	72	5	610	1772	463	613	35.1	38.1	46.2	302	184	91.9	68.8	79.2	83.8	907
<b>81 Tonnes</b>																	
C90Q20BS	2103920	81	4	508	1670	338	511	35.1	38.1	46.2	302	184	91.9	68.8	79.2	73.7	617
C90Q24BS	2103922	81	4	610	1772	338	613	35.1	38.1	46.2	302	184	91.9	68.8	79.2	73.7	780
C90QN20BS	2103930	81	5	508	1670	463	511	35.1	38.1	46.2	302	184	91.9	68.8	79.2	83.8	721
C90QN24BS	2103932	81	5	610	1772	463	613	35.1	38.1	46.2	302	184	91.9	68.8	79.2	83.8	934
<b>90 Tonnes</b>																	
C100QN20BS	2103970	90	5	508	1670	463	511	35.1	38.1	46.2	302	184	91.9	68.8	79.2	83.8	721
C100QN24BS	2103972	90	5	610	1772	463	613	35.1	38.1	46.2	302	184	91.9	68.8	79.2	83.8	934
C100SX20BS	2103980	90	6	508	1670	518	511	35.1	38.1	46.2	302	184	91.9	68.8	79.2	73.7	755
C100SX24BS	2103982	90	6	610	1772	518	613	35.1	38.1	46.2	302	184	91.9	68.8	79.2	73.7	977



# QUIC-KIT

## The McKissick QUIC-KIT®

### Featuring the McKissick® 750 Bridge Crane Block

The patented McKissick QUIC-KIT® system is a revolutionary concept that provides you the ability to build a factory quality replacement bridge crane block where you need it, when you need it.

The QUIC-KIT® system provides the components needed to build up to 32 possible combinations of a 750 bridge crane block; all in one kit that can be easily assembled on site.

#### Features of the McKissick QUIC-KIT® include:

- **Reduced downtime** — A replacement block can be assembled in minutes from kit components utilizing tools and assembly instructions provided in each kit.
- **Multiple versions of two sheave blocks** — Up to 32 possible block combinations are included in the 752 series block kit. Each kit contains three WireLine sizes and two center pins with multiple sheave spacers.
- **Adjustable sheave spacing in 1/2" increments** — Center pin design gives you the ability to assemble the replacement block to meet your spacing requirement.
- **The McKissick QUIC-KIT®** — Comes complete in a durable carrying case for easy transport and for storing components on the work site or warehouse.

Crosby has established a call center to answer questions concerning the QUIC-KIT, 750 series blocks or other McKissick® blocks. To reach the call center, simply call the Block Hotline number, (800) 727-1555.



WLL (t)	751K Stock No.	Sheave O.D. (in.)	Pitch Diameter		Sheave Wire	
			(in.)	(mm)	(in.)	(mm)
2	1003542	6.5	5.69	151	1/4, 5/16, 3/8	6.5, 8, 9-10
3	1003551	8	7.38	187	1/4, 5/16, 3/8, 7/16, 1/2	6.5, 8, 9-10, 11, 12-13
5	1003560	10	9.25	235	3/8, 7/16, 1/2, 9/16, 5/8	9-10, 11, 12-13, 14, 16
7.5	1003579	12	11.00	279	1/2, 9/16, 5/8, 3/4	12-13, 14, 16, 19
10	1003588	14	12.50	318	5/8, 3/4, 7/8, 1	16, 19, 22, 25-26

WLL (t)	752K Stock No.	Sheave O.D. (in.)	Sheave Spacing Centerline		Pitch Diameter		Sheave Wire	
			(in.)	(mm)	(in.)	(mm)	(in.)	(mm)
3	1003595	6.5	3.25-5	82.6-127	5.95	150-152	1/4, 5/16, 3/8	6.5, 8, 9-10
5	1003604	8	4.5-6.5	114-165	7.38	183-191	1/4, 5/16, 3/8, 7/16, 1/2	6.5, 8, 9-10, 11, 12-13
7.5	1003613	10	5.25-7.75	133-203	9.25	228-236	3/8, 7/16, 1/2, 9/16, 5/8	9-10, 11, 12-13, 14, 16
10	1003622	12	6.5-10	165-254	11	273-282	1/2, 9/16, 5/8, 3/4	12-13, 14, 16, 19
15	1003631	12	7.5-11	191-279	11	273-282	1/2, 9/16, 5/8, 3/4	12-13, 14, 16, 19



- Wide range of product available (see tables below).
- Removable housing allows block to be reeved without complete disassembly.
- Bearing life and Design Factors meet:
  - ASME HST-4, Class H
  - CMAA 70 Class D
  - FEM9.511 Class 2m
  - ISO 4301.1 Class M5
- Adjustable sheave spacing in 1/2" increments (1/4" on 6-1/2" size).
- Sheave pitch diameter minimum of 16 times rope diameter on standard sizes.
- All single point shank hooks are genuine Crosby®, forged alloy steel, Quenched and Tempered, contain the patented **QUIC-CHECK®** markings and come with a world class latch that integrates with hook tip.
- **Patented**
- All sizes are **RFID EQUIPPED**.
- Sheave bearings are maintenance free and sealed for life (10,000 hrs.).
- Ability to attach optional anti two-block device.
- Available with shackle as lower connection point.
- Ultimate load is 5 times the Working Load Limit.

Key to McKissick® Easy-Lift® Overhead Bridge Crane Blocks					
Single and Double Sheave Blocks				Double Sheave Blocks Only	
<b>BC</b>	<b>05</b>	<b>D</b>	<b>08</b>	<b>B</b>	<b>36</b>
↓	↓	↓	↓	↓	↓
McKissick® 750 Series Bridge Crane Blocks	Working Load Limit (t)	Number of Sheaves S = 1 D = 2	Sheave Diameter (in.)	Center Pin Designation	Sheave Spacing in 1/8" Increments



**BC-751**  
Single  
Sheave

### BC-751 Single Sheave

Model 751 – Single Sheave					
WLL (t)	2	3	5	7.5	10
Sheave O.D.	6.5" 165mm	8" 203mm	10" 254mm	12" 305mm	14" 356mm
Pitch Diameter	5.69" 151mm	7.38" 187mm	9.25" 235mm	11" 279mm	12.5" 318mm
Wireline*					
1/4" 6.5mm					
5/16" 8mm					
3/8" 9 - 10mm					
7/16" 11mm					
1/2" 12 - 13mm					
9/16" 14mm					
5/8" 16mm					
3/4" 19mm					
7/8" 22mm					
1" 25 - 26mm					

\* Additional Wireline sizes available.

### BC-752 Double Sheave

Model 752 – Double Sheave					
WLL (t)	3	5	10	15	
Sheave O.D. (mm)	6.5" 165mm	8" 203mm	10" 254mm	12" 305mm	14" 356mm
Sheave Spacing Centerline (mm)	3.25" - 5"	4.5" - 6.5"	5.25" - 7.75"	6.5" - 10"	7.5" - 11"
Pitch Diameter (mm)	82.6 - 127mm	114 - 165mm	133 - 203mm	165 - 254mm	191 - 279mm
	5.95"	7.38"	9.25"	11"	11"
	150 - 152mm	183 - 191mm	228 - 236mm	273 - 282mm	273 - 282mm
Wireline*					
1/4" 6.5mm					
5/16" 8mm					
3/8" 9 - 10mm					
7/16" 11mm					
1/2" 12 - 13mm					
9/16" 14mm					
5/8" 16mm					
3/4" 19mm					

\* Additional Wireline sizes available.

= Primary Wireline Size

= Other Wireline Sizes



**BC-752**  
Double Sheave

# McKissick® Overhead Bridge Crane Blocks

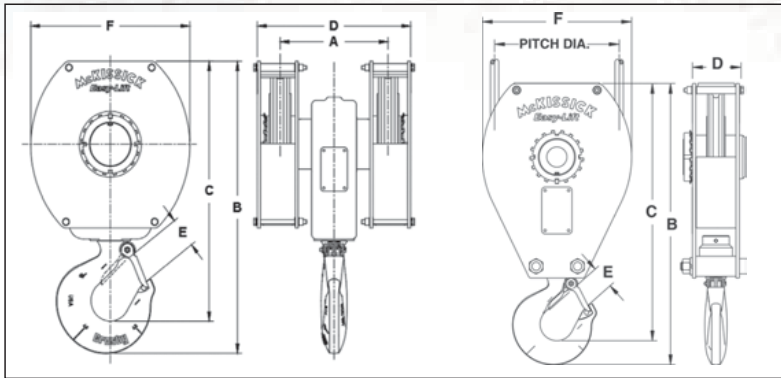

All sizes are RFID EQUIPPED.

## 751 Series Bridge Crane Blocks

Model No.	BC-751 Stock No.	Working Load Limit (t)*	Sheave Diam. (mm)	Dimensions (mm)					Standard Wire Line Size (mm)	Weight Each (kg)
				B	C	D	E	F		
<b>2 Metric Tons</b>										
BC02S06	2022539	2	165	354	325	53.8	29.5	189	6	8.2
BC02S06	2022540	2	165	354	325	53.8	29.5	189	8	8.2
BC02S06	2022541	2	165	354	325	53.8	29.5	189	10	8.2
<b>3 Metric Tons</b>										
BC03S08	2022521	3	203	429	391	69.8	34.5	227	6	16
BC03S08	2022522	3	203	429	391	69.8	34.5	227	8	16
BC03S08	2022523	3	203	429	391	69.8	34.5	227	10	16
BC03S08	2022524	3	203	429	391	69.8	34.5	227	11	16
BC03S08	2022525	3	203	429	391	69.8	34.5	227	13	16
<b>5 Metric Tons</b>										
BC05S10	2022526	5	254	533	487	88.9	40.9	282	10	27
BC05S10	2022527	5	254	533	487	88.9	40.9	282	11	27
BC05S10	2022528	5	254	533	487	88.9	40.9	282	13	27
BC05S10	2022529	5	254	533	487	88.9	40.9	282	14	27
BC05S10	2022530	5	254	533	487	88.9	40.9	282	16	27
<b>7.5 Metric Tons</b>										
BC07S12	2022531	7.5	305	646	589	108	52.8	341	13	52
BC07S12	2022532	7.5	305	646	589	108	52.8	341	14	52
BC07S12	2022533	7.5	305	646	589	108	52.8	341	16	52
BC07S12	2022534	7.5	305	646	589	108	52.8	341	19	52
<b>10 Metric Tons</b>										
BC10S14	2022535	10	356	740	673	127	57.7	394	16	70
BC10S14	2022536	10	356	740	673	127	57.7	394	19	70
BC10S14	2022537	10	356	740	673	127	57.7	394	22	70
BC10S14	2022538	10	356	740	673	127	57.7	394	25	70

\* Ultimate Load is 5 times the Working Load Limit

## 752 Series Bridge Crane Blocks

Model No.	BC-752 Stock No.	Working Load Limit (t)*	Sheave Diam. (mm)	Dimensions (mm)						Standard Wire Line Size (mm)	Weight Each (kg)
				A	B	C	D	E	F		
<b>3 Metric Tons</b>											
BC03D06M26	2022731	3	165	82.6	341	304	146	34.5	189	6	16.8
BC03D06M26	2022739	3	165	82.6	341	304	146	34.5	189	8	16.8
BC03D06M26	2022747	3	165	82.6	341	304	146	34.5	189	10	16.8
BC03D06M28	2022732	3	165	88.9	341	304	146	34.5	189	6	16.8
BC03D06M28	2022740	3	165	88.9	341	304	146	34.5	189	8	16.8
BC03D06M28	2022748	3	165	88.9	341	304	146	34.5	189	10	16.8
BC03D06M30	2022733	3	165	95.3	341	304	146	34.5	189	6	16.8
BC03D06M30	2022741	3	165	95.3	341	304	146	34.5	189	8	16.8
BC03D06M30	2022749	3	165	95.3	341	304	146	34.5	189	10	16.8
BC03D06M32	2022734	3	165	102	341	304	146	34.5	189	6	16.8
BC03D06M32	2022742	3	165	102	341	304	146	34.5	189	8	16.8
BC03D06M32	2022750	3	165	102	341	304	146	34.5	189	10	16.8
BC03D06N34	2022735	3	165	108	341	304	171	34.5	189	6	16.8
BC03D06N34	2022743	3	165	108	341	304	171	34.5	189	8	16.8
BC03D06N34	2022751	3	165	108	341	304	171	34.5	189	10	16.8
BC03D06N36	2022736	3	165	114	341	304	171	34.5	189	6	16.8
BC03D06N36	2022744	3	165	114	341	304	171	34.5	189	8	16.8
BC03D06N36	2022752	3	165	114	341	304	171	34.5	189	10	16.8
BC03D06N38	2022737	3	165	121	341	304	171	34.5	189	6	16.8
BC03D06N38	2022745	3	165	121	341	304	171	34.5	189	8	16.8
BC03D06N38	2022753	3	165	121	341	304	171	34.5	189	10	16.8
BC03D06N40	2022738	3	165	127	341	304	171	34.5	189	6	16.8
BC03D06N40	2022746	3	165	127	341	304	171	34.5	189	8	16.8
BC03D06N40	2022754	3	165	127	341	304	171	34.5	189	10	16.8



# McKissick® Overhead Bridge Crane Blocks

## 752 Series Bridge Crane Blocks

Model No.	BC-752 Stock No.	Working Load Limit (t)*	Sheave Diam. (mm)	Dimensions (mm)						Standard Wireline Size (mm)	Weight Each (kg)
				A	B	C	D	E	F		
<b>5 Metric Tons</b>											
BC05D08B36	2022550	5	203	114	417	371	195	40.9	227	6	34
BC05D08B36	2022551	5	203	114	417	371	195	40.9	227	8	34
BC05D08B36	2022552	5	203	114	417	371	195	40.9	227	10	34
BC05D08B36	2022553	5	203	114	417	371	195	40.9	227	11	34
BC05D08B36	2022554	5	203	114	417	371	195	40.9	227	13	34
BC05D08B40	2022555	5	203	127	417	371	195	40.9	227	6	34
BC05D08B40	2022556	5	203	127	417	371	195	40.9	227	8	34
BC05D08B40	2022557	5	203	127	417	371	195	40.9	227	10	34
BC05D08B40	2022558	5	203	127	417	371	195	40.9	227	11	34
BC05D08B40	2022559	5	203	127	417	371	195	40.9	227	13	34
BC05D08B44	2022560	5	203	140	417	371	195	40.9	227	6	34
BC05D08B44	2022561	5	203	140	417	371	195	40.9	227	8	34
BC05D08B44	2022562	5	203	140	417	371	195	40.9	227	10	34
BC05D08B44	2022563	5	203	140	417	371	195	40.9	227	11	34
BC05D08B44	2022564	5	203	140	417	371	195	40.9	227	13	34
BC05D08C44	2022565	5	203	140	417	371	221	40.9	227	6	34
BC05D08C44	2022566	5	203	140	417	371	221	40.9	227	8	34
BC05D08C44	2022567	5	203	140	417	371	221	40.9	227	10	34
BC05D08C44	2022568	5	203	140	417	371	221	40.9	227	11	34
BC05D08C44	2022569	5	203	140	417	371	221	40.9	227	13	34
BC05D08C48	2022570	5	203	152	417	371	221	40.9	227	6	34
BC05D08C48	2022571	5	203	152	417	371	221	40.9	227	8	34
BC05D08C48	2022572	5	203	152	417	371	221	40.9	227	10	34
BC05D08C48	2022573	5	203	152	417	371	221	40.9	227	11	34
BC05D08C48	2022574	5	203	152	417	371	221	40.9	227	13	34
BC05D08C52	2022575	5	203	165	417	371	221	40.9	227	6	34
BC05D08C52	2022576	5	203	165	417	371	221	40.9	227	8	34
BC05D08C52	2022577	5	203	165	417	371	221	40.9	227	10	34
BC05D08C52	2022578	5	203	165	417	371	221	40.9	227	11	34
BC05D08C52	2022579	5	203	165	417	371	221	40.9	227	13	34
<b>7.5 Metric Tons</b>											
BC07D10D42	2022580	7.5	254	133	514	457	221	52.8	282	10	57
BC07D10D42	2022581	7.5	254	133	514	457	221	52.8	282	11	57
BC07D10D42	2022582	7.5	254	133	514	457	221	52.8	282	13	57
BC07D10D42	2022583	7.5	254	133	514	457	221	52.8	282	14	57
BC07D10D42	2022584	7.5	254	133	514	457	221	52.8	282	16	57
BC07D10D46	2022585	7.5	254	146	514	457	221	52.8	282	10	57
BC07D10D46	2022586	7.5	254	146	514	457	221	52.8	282	11	57
BC07D10D46	2022587	7.5	254	146	514	457	221	52.8	282	13	57
BC07D10D46	2022588	7.5	254	146	514	457	221	52.8	282	14	57
BC07D10D46	2022589	7.5	254	146	514	457	221	52.8	282	16	57
BC07D10D50	2022590	7.5	254	159	514	457	221	52.8	282	10	57
BC07D10D50	2022591	7.5	254	159	514	457	221	52.8	282	11	57
BC07D10D50	2022592	7.5	254	159	514	457	221	52.8	282	13	57
BC07D10D50	2022593	7.5	254	159	514	457	221	52.8	282	14	57
BC07D10D50	2022594	7.5	254	159	514	457	221	52.8	282	16	57
BC07D10E48	2022595	7.5	254	152	514	457	240	52.8	282	10	57
BC07D10E48	2022596	7.5	254	152	514	457	240	52.8	282	11	57
BC07D10E48	2022597	7.5	254	152	514	457	240	52.8	282	13	57
BC07D10E48	2022598	7.5	254	152	514	457	240	52.8	282	14	57
BC07D10E48	2022599	7.5	254	152	514	457	240	52.8	282	16	57
BC07D10E52	2022600	7.5	254	165	514	457	240	52.8	282	10	57
BC07D10E52	2022601	7.5	254	165	514	457	240	52.8	282	11	57
BC07D10E52	2022602	7.5	254	165	514	457	240	52.8	282	13	57
BC07D10E52	2022603	7.5	254	165	514	457	240	52.8	282	14	57
BC07D10E52	2022604	7.5	254	165	514	457	240	52.8	282	16	57
BC07D10E56	2022605	7.5	254	178	514	457	240	52.8	282	10	57
BC07D10E56	2022606	7.5	254	178	514	457	240	52.8	282	11	57
BC07D10E56	2022607	7.5	254	178	514	457	240	52.8	282	13	57
BC07D10E56	2022608	7.5	254	178	514	457	240	52.8	282	14	57
BC07D10E56	2022609	7.5	254	178	514	457	240	52.8	282	16	57
BC07D10F56	2022610	7.5	254	178	514	457	265	52.8	282	10	57
BC07D10F56	2022611	7.5	254	178	514	457	265	52.8	282	11	57
BC07D10F56	2022612	7.5	254	178	514	457	265	52.8	282	13	57
BC07D10F56	2022613	7.5	254	178	514	457	265	52.8	282	14	57
BC07D10F56	2022614	7.5	254	178	514	457	265	52.8	282	16	57
BC07D10F60	2022615	7.5	254	191	514	457	265	52.8	282	10	57
BC07D10F60	2022616	7.5	254	191	514	457	265	52.8	282	11	57
BC07D10F60	2022617	7.5	254	191	514	457	265	52.8	282	13	57
BC07D10F60	2022618	7.5	254	191	514	457	265	52.8	282	14	57
BC07D10F60	2022619	7.5	254	191	514	457	265	52.8	282	16	57

# McKissick® Overhead Bridge Crane Blocks



## 752 Series Bridge Crane Blocks

Model No.	BC-752 Stock No.	Working Load Limit (t)*	Sheave Diam. (mm)	Dimensions (mm)						Standard Wireline Size (mm)	Weight Each (kg)
				A	B	C	D	E	F		
BC07D10F64	2022620	7.5	254	203	514	457	265	52.8	282	10	57
BC07D10F64	2022621	7.5	254	203	514	457	265	52.8	282	11	57
BC07D10F64	2022622	7.5	254	203	514	457	265	52.8	282	13	57
BC07D10F64	2022623	7.5	254	203	514	457	265	52.8	282	14	57
BC07D10F64	2022624	7.5	254	203	514	457	265	52.8	282	16	57
<b>10 Metric Tons</b>											
BC10D12G52	2022625	10	305	165	590	524	278	57.7	342	13	109
BC10D12G52	2022626	10	305	165	590	524	278	57.7	342	14	109
BC10D12G52	2022627	10	305	165	590	524	278	57.7	342	16	109
BC10D12G52	2022628	10	305	165	590	524	278	57.7	342	19	109
BC10D12G56	2022629	10	305	178	590	524	278	57.7	342	13	109
BC10D12G56	2022630	10	305	178	590	524	278	57.7	342	14	109
BC10D12G56	2022631	10	305	178	590	524	278	57.7	342	16	109
BC10D12G56	2022632	10	305	178	590	524	278	57.7	342	19	109
BC10D12G60	2022633	10	305	191	590	524	278	57.7	342	13	109
BC10D12G60	2022634	10	305	191	590	524	278	57.7	342	14	109
BC10D12G60	2022635	10	305	191	590	524	278	57.7	342	16	109
BC10D12G60	2022636	10	305	191	590	524	278	57.7	342	19	109
BC10D12G64	2022637	10	305	203	590	524	278	57.7	342	13	109
BC10D12G64	2022638	10	305	203	590	524	278	57.7	342	14	109
BC10D12G64	2022639	10	305	203	590	524	278	57.7	342	16	109
BC10D12G64	2022640	10	305	203	590	524	278	57.7	342	19	109
BC10D12I68	2022657	10	305	216	590	524	329	57.7	342	13	109
BC10D12I68	2022658	10	305	216	590	524	329	57.7	342	14	109
BC10D12I68	2022659	10	305	216	590	524	329	57.7	342	16	109
BC10D12I68	2022660	10	305	216	590	524	329	57.7	342	19	109
BC10D12I72	2022661	10	305	229	590	524	329	57.7	342	13	109
BC10D12I72	2022662	10	305	229	590	524	329	57.7	342	14	109
BC10D12I72	2022663	10	305	229	590	524	329	57.7	342	16	109
BC10D12I72	2022664	10	305	229	590	524	329	57.7	342	19	109
BC10D12I76	2022665	10	305	241	590	524	329	57.7	342	13	109
BC10D12I76	2022666	10	305	241	590	524	329	57.7	342	14	109
BC10D12I76	2022667	10	305	241	590	524	329	57.7	342	16	109
BC10D12I76	2022668	10	305	241	590	524	329	57.7	342	19	109
BC10D12I80	2022669	10	305	254	590	524	329	57.7	342	13	109
BC10D12I80	2022670	10	305	254	590	524	329	57.7	342	14	109
BC10D12I80	2022671	10	305	254	590	524	329	57.7	342	16	109
BC10D12I80	2022672	10	305	254	590	524	329	57.7	342	19	109
<b>15 Metric Tons</b>											
BC15D12J60	2022673	15	305	191	645	568	303	76.7	342	13	122
BC15D12J60	2022674	15	305	191	645	568	303	76.7	342	14	122
BC15D12J60	2022675	15	305	191	645	568	303	76.7	342	16	122
BC15D12J60	2022676	15	305	191	645	568	303	76.7	342	19	122
BC15D12J64	2022677	15	305	203	645	568	303	76.7	342	13	122
BC15D12J64	2022678	15	305	203	645	568	303	76.7	342	14	122
BC15D12J64	2022679	15	305	203	645	568	303	76.7	342	16	122
BC15D12J64	2022680	15	305	203	645	568	303	76.7	342	19	122
BC15D12J68	2022681	15	305	216	645	568	303	76.7	342	13	122
BC15D12J68	2022682	15	305	216	645	568	303	76.7	342	14	122
BC15D12J68	2022683	15	305	216	645	568	303	76.7	342	16	122
BC15D12J68	2022684	15	305	216	645	568	303	76.7	342	19	122
BC15D12J72	2022685	15	305	229	645	568	303	76.7	342	13	122
BC15D12J72	2022686	15	305	229	645	568	303	76.7	342	14	122
BC15D12J72	2022687	15	305	229	645	568	303	76.7	342	16	122
BC15D12J72	2022688	15	305	229	645	568	303	76.7	342	19	122
BC15D12L76	2022705	15	305	241	645	568	354	76.7	342	13	122
BC15D12L76	2022706	15	305	241	645	568	354	76.7	342	14	122
BC15D12L76	2022707	15	305	241	645	568	354	76.7	342	16	122
BC15D12L76	2022708	15	305	241	645	568	354	76.7	342	19	122
BC15D12L80	2022709	15	305	254	645	568	354	76.7	342	13	122
BC15D12L80	2022710	15	305	254	645	568	354	76.7	342	14	122
BC15D12L80	2022711	15	305	254	645	568	354	76.7	342	16	122
BC15D12L80	2022712	15	305	254	645	568	354	76.7	342	19	122
BC15D12L84	2022713	15	305	267	645	568	354	76.7	342	13	122
BC15D12L84	2022714	15	305	267	645	568	354	76.7	342	14	122
BC15D12L84	2022715	15	305	267	645	568	354	76.7	342	16	122
BC15D12L84	2022716	15	305	267	645	568	354	76.7	342	19	122
BC15D12L88	2022717	15	305	279	645	568	354	76.7	342	13	122
BC15D12L88	2022718	15	305	279	645	568	354	76.7	342	14	122
BC15D12L88	2022719	15	305	279	645	568	354	76.7	342	16	122
BC15D12L88	2022720	15	305	279	645	568	354	76.7	342	19	122

\* Ultimate Load is 5 times the Working Load Limit

**UB500 Series Top Swiveling Overhaul Balls**



All sizes are RFID EQUIPPED



With **S320**  
Eye Hook



With **S1316 A SHUR-LOC®**  
Eye Hook



Both styles available with optional **McKissick®** Wedge Socket Assembly or S-421 **TERMINATOR** Wedge Socket



**UWO 422T**  
**TERMINATOR**  
Wedge Only

- Sizes 4 Tons through 10 Tons available with Crosby's S1316A "Positive Locking" SHUR-LOC® hook which may be used for lifting personnel. Meets the intent of OSHA Rule 1926.1431(g)(1)(i)(A) and 1926.1501(g)(4)(iv)(B).
- Design Factor 4:1.
- The top swivel design on the UB500 assures the ball remains stationary if the Wireline spins.
- The swivel incorporates a sealed roller thrust bearing together with a grease fitting for easy lubrication.
- Each ball can be equipped with the new McKissick® US-422T

Wedge Socket which can be easily adjusted to fit various sizes of Wireline by changing the wedge (Ensure that correct wedge is used for selected Wireline size).

- All hooks used on UB500 Overhaul Balls (S320, S320N & S1316A) are forged from alloy steel. The S320 and S320N hooks come complete with latches.
- The S320 hook (PL latch) and the S320N hook (S4320 latch), with the proper latch attached, may be used for personnel lifting when secured with proper device (Bolt, nut and pin for the PL latch; Cotter pin for the S4320 latch). Meets the intent of OSHA Rule 1926.1431(g)(1)(i)(A) and 1926.1501(g)(4)(iv)(B).

**Overhaul Ball Assembly**

**Optional US-422T Wedge Sockets**

Overhaul Ball Assembly					Optional US-422T Wedge Sockets						Optional S-421T TERMINATOR Wedge Socket Assembly	
McKissick® UB500 Model No.	UB500 "D" Eye Hook Stock No.	UB500 "S" SHUR-LOC® Stock No.	Working Load Limit (t)	Weight Each (kg)	Wire Rope Size (mm)	Model No.	Wedge Socket Assy. Stock No.	Weight Each (kg)	Wedge Only Stock No.	Weight Each (kg)	Wire Rope Size (mm)	S-421T Stock No.
MB4T35	1054165	1036005	3.6	26.3	10	US4T	1044300	2.1	1047310	.27	13	1035009
MB4T85	1054174	1036018	3.6	46.3	11	US4T	1044309	2.1	1047301	.27	16	1035018
MB4T150	1054183	1036032	3.6	73.5	13	US4T	1044318	2.1	1047329	.27		
MB4T200	1054192	1036041	3.6	91.2	13	US5T	1044327	3.9	1047338	.45		
MB7T85	1054209	1036050	6.3	49.4	14	US5T	1044336	3.9	1047347	.45		
MB7T150	1054218	1036063	6.3	77.1	16	US5T	1044345	3.9	1047356	.45		
MB7T200	1054227	1036077	6.3	95.3	16	US6T	1044354	4.3	1047365	.64		
MB7T285	1054236	1036086	6.3	146	19	US6T	1044363	4.3	1047374	.64		
MB10T150	1054245	1036095	9.0	98	16	US6T	1044354	4.3	1047365	.64	19	1035027
MB10T200	1054254	1036108	9.0	118	19	US6T	1044363	4.3	1047374	.64	22	1035036
MB10T285	1054263	1036122	9.0	166	22	US8T	1044404	9.4	1047425	3.4		
MB10T350	1054272	1036131	9.0	183	25	US8T	1044417	9.4	1047431	3.9		
MB10T650	1054281	1036140	9.0	326	28	US10T	1044426	21.1	1047440	5.7		
MB12T150	1054290	1036520	10.8	98	32	US10T	1044435	21.1	1047459	6.8		
MB12T200	1054307	1036529	10.8	117								
MB12T285	1054316	1036538	10.8	166								
MB12T350	1054325	1036547	10.8	183								
MB12T650	1054334	1036556	10.8	326								
MB15T200	1054343	1036565	13.5	135	16	US8AT	1044372	7.9	1047383	2.0	19	1035027
MB15T350	1054352	1036574	13.5	207	19	US8AT	1044381	7.9	1047392	2.2	22	1035036
MB15T650	1054361	1036583	13.5	342	22	US8T	1044404	9.4	1047425	3.4		
MB15T1150	1054370	1036592	13.5	595	25	US8T	1044417	9.4	1047431	3.9		
MB20T200	1054389	1036611	18.0	135	28	US10T	1044426	21.1	1047440	5.7		
MB20T350	1054398	1036620	18.0	207	32	US10T	1044435	21.1	1047459	6.8		
MB20T650	1054405	1036629	18.0	342								
MB20T1150	1054414	1036638	18.0	595								
MB25T350	1054423	1036647	22.5	242								
MB25T650	1054432	1036656	22.5	392								
MB25T1150	1054441	1036665	22.5	645								
MB30T650	1054450	1036674	27.0	392								
MB30T1150	1054469	1036683	27.0	645								





UB-500 NON SWIVEL OVERHAUL BALLS



All sizes are RFID EQUIPPED.

UB-500E Top Swivel Overhaul Balls with 320 Eye Hooks

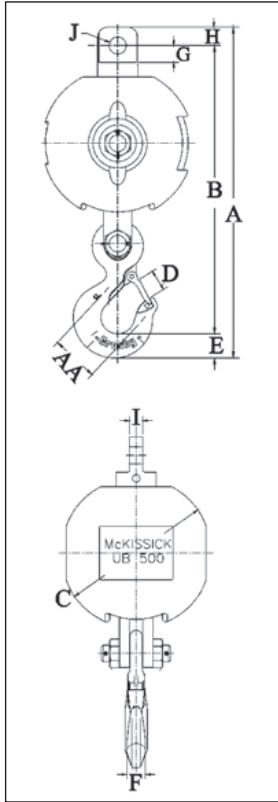

Model No.*	UB-500 "E" Stock No.	Dimensions (mm)										
		A	B	C	D	E	F	G	H	I	J	AA
MB4T35*	1036000	510	439	191	34.5	36.6	28.4	47.8	35.1	22.4	33.3	63.5
MB4T85*	1036009	533	461	235	34.5	36.6	28.4	47.8	35.1	22.4	33.3	63.5
MB4T150*	1036027	558	487	286	34.5	36.6	28.4	47.8	35.1	22.4	33.3	63.5
MB4T200*	1036036	568	496	318	34.5	36.6	28.4	47.8	35.1	22.4	33.3	63.5
MB7T85*	1036045	589	517	235	40.9	46.0	35.1	47.8	35.1	22.4	33.3	76.0
MB7T150*	1036054	624	543	286	40.9	46.0	35.1	47.8	35.1	22.4	33.3	76.0
MB7T200*	1036072	632	551	318	40.9	46.0	35.1	47.8	35.1	22.4	33.3	76.0
MB7T285*	1036081	657	576	353	40.9	46.0	35.1	47.8	35.1	22.4	33.3	76.0
MB10T150*	1036090	799	691	286	53.0	57.0	41.1	70.0	51.0	22.4	45.2	102
MB10T200*	1036099	808	700	318	53.0	57.0	41.1	70.0	51.0	31.8	45.2	102
MB10T285*	1036117	832	724	353	53.0	57.0	41.1	70.0	51.0	31.8	45.2	102
MB10T350*	1036126	846	738	381	53.0	57.0	41.1	70.0	51.0	31.8	45.2	102
MB10T650*	1036135	884	776	456	53.0	57.0	41.1	70.0	51.0	31.8	45.2	102
MB12T150*	1036144	799	691	286	53.0	57.0	41.1	70.0	51.0	31.8	45.2	102
MB12T200*	1036153	808	700	318	53.0	57.0	41.1	70.0	51.0	31.8	45.2	102
MB12T285*	1036171	832	724	353	53.0	57.0	41.1	70.0	51.0	31.8	45.2	102
MB12T350*	1036180	846	738	381	53.0	57.0	41.1	70.0	51.0	31.8	45.2	102
MB12T650*	1036189	909	776	456	53.0	57.0	41.1	70.0	51.0	31.8	45.2	102
MB15T200*	1036198	955	828	318	76.5	76.0	60.5	60.5	51.0	31.8	45.2	127
MB15T350*	1036207	986	859	381	76.5	76.0	60.5	60.5	51.0	31.8	45.2	127
MB15T650*	1036216	1022	895	456	76.5	76.0	60.5	60.5	51.0	31.8	45.2	127
MB15T1150*	1036225	1072	945	549	76.5	76.0	60.5	60.5	51.0	31.8	45.2	127
MB20T200*	1036234	955	828	318	76.5	76.0	60.5	60.5	51.0	31.8	45.2	127
MB20T350*	1036243	986	859	381	76.5	76.0	60.5	60.5	51.0	31.8	45.2	127
MB20T650*	1036252	1022	895	456	76.5	76.0	60.5	60.5	51.0	31.8	45.2	127
MB20T1150*	1036261	1072	945	549	76.5	76.0	60.5	60.5	51.0	31.8	45.2	127
MB25T350	1036270	1198	1021	381	76.0	92.0	76.0	84.0	70.0	44.5	45.2	165
MB25T650	1036279	1248	1086	456	76.0	92.0	76.0	84.0	70.0	44.5	45.2	165
MB25T1150	1036288	1297	1135	549	76.0	92.0	76.0	84.0	70.0	44.5	45.2	165
MB30T650	1036297	1248	1086	456	76.0	92.0	76.0	84.0	70.0	44.5	45.2	165
MB30T1150	1036306	1297	1135	549	76.0	92.0	76.0	84.0	70.0	44.5	45.2	165

\* 4 Ton thru 20 Ton models use Crosby "N" style hooks with integrated latch. All sizes are RFID EQUIPPED.

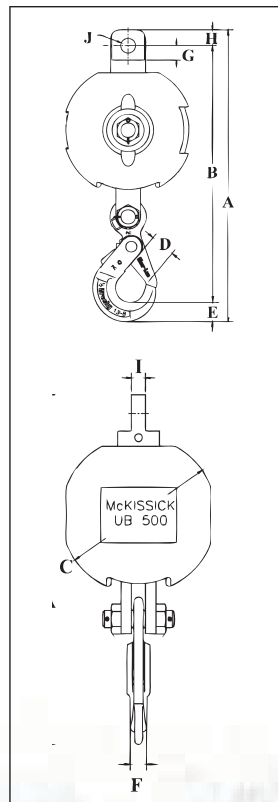

UB-500S Top Swivel Overhaul Balls with SHUR-LOC® Hooks

Model No.	UB-500 "S" Stock No.	Dimensions (mm)									
		A	B	C	D	E	F	G	H	I	J
MB4T35	1036005	525	462	191	46.5	29.2	23.9	47.8	35.1	22.4	33.3
MB4T85	1036018	547	484	235	46.5	29.2	23.9	47.8	35.1	22.4	33.3
MB4T150	1036032	573	509	286	46.5	29.2	23.9	47.8	35.1	22.4	33.3
MB4T200	1036041	582	519	318	46.5	29.2	23.9	47.8	35.1	22.4	33.3
MB7T85	1036050	607	541	235	53.5	42.2	29.5	47.8	35.1	22.4	33.3
MB7T150	1036063	642	566	286	53.5	42.2	29.5	47.8	35.1	22.4	33.3
MB7T200	1036077	650	575	318	53.5	42.2	29.5	47.8	35.1	22.4	33.3
MB7T285	1036086	675	600	353	53.5	42.2	29.5	47.8	35.1	22.4	33.3
MB10T150	1036095	793	691	286	63.0	52.5	38.1	70.0	51.0	31.8	45.2
MB10T200	1036108	803	700	318	63.0	52.5	38.1	70.0	51.0	31.8	45.2
MB10T285	1036122	827	724	353	63.0	52.5	38.1	70.0	51.0	31.8	45.2
MB10T350	1036131	841	738	381	63.0	52.5	38.1	70.0	51.0	31.8	45.2
MB10T650	1036140	879	776	456	63.0	52.5	38.1	70.0	51.0	31.8	45.2

All sizes are RFID EQUIPPED.

**UB500 Series Non Swiveling Overhaul Balls**



All sizes are RFID EQUIPPED



Key to McKissick® UB500 Utility Overhaul Ball Model Number				
<b>MB</b>	<b>4</b>	<b>T</b>	<b>35</b>	<b>E</b>
↓	↓	↓	↓	↓
McKissick® Utility Overhead Ball	Working Load Limit (Tons)	Swivel Style T = Top NS = Non	Ball Only Weight	Hook Style E = 320 or 320N S = SHUR-LOC® Eye Hook



With **S320** Eye Hook



With **S1316 A SHUR-LOC®** Eye Hook



Both styles available with optional McKissick® Wedge Socket Assembly or S-421 TERMINATOR Wedge Socket



**UWO 422T TERMINATOR** Wedge Only

- Sizes 4 Tons through 10 Tons available with Crosby's S1316A "Positive Locking" SHUR-LOC® hook which may be used for lifting personnel. Meets the intent of OSHA Rule 1926.1431(g)(1)(i)(A) and 1926.1501(g)(4)(iv)(B).
- Design Factor 4:1.
- Each ball can be equipped with the new McKissick® US-422T Wedge Socket which can be easily adjusted to fit various sizes of Wireline by changing the wedge (Ensure that correct wedge is used for selected Wireline size).
- All hooks used on UB500 Overhaul Balls (S320, S320N & S1316A) are forged from alloy steel. The S320 and S320N hooks come complete with latches.
- The S320 hook (PL latch) and the S320N hook (S4320 latch), with the proper latch attached, may be used for personnel lifting when secured with proper device (Bolt, nut and pin for the PL latch; Cotter pin for the S4320 latch). Meets the intent of OSHA Rule 1926.1431(g)(1)(i)(A) and 1926.1501(g)(4)(iv)(B).

**Overhaul Ball Assembly**

**Optional US-422T Wedge Sockets**

McKissick® UB500 Model No.	UB500 "E" Eye Hook Stock No.	UB500 "S" SHUR-LOC® Stock No.	Working Load Limit (t)	Weight Each (kg)	Wireline Size (mm)	Wedge Socket Assy. Model No.	Wedge Socket Assy. Stock No.	Weight Each (kg)	Wedge Only Assy. Stock No.	Weight Each (kg)
MB4NS35	1036402*	1036407	3.6	24.5						
MB4NS85	1036411*	1036416	3.6	44.5	9.6	US4T	1044300	2.1	1047310	0.27
MB4NS150	1036420*	1036425	3.6	71.5	11	US4T	1044309	2.1	1047301	0.27
MB4NS200	1036429*	1036434	3.6	90.7	13	US4T	1044318	2.1	1047329	0.27
MS7NS85	1036438*	1036443	6.3	47.2	13	US5T	1044327	3.9	1047338	0.45
MB7NS150	1036447*	1036452	6.3	74.8	14	US5T	1044336	3.9	1047347	0.45
MB7NS200	1036456*	1036461	6.3	92.9	16	US5T	1044345	3.9	1047356	0.45
MB7NS285	1036465*	1036470	6.3	143	16	US6T	1044354	4.3	1047365	0.64
MB10NS150	1036474*	1036479	9.0	89.8	19	US6T	1044363	4.3	1047374	0.64
MB10NS200	1036483*	1036488	9.0	110	22	US8T	1044404	9.4	1047425	1.4
MB10NS285	1036492*	1036497	9.0	157	25	US8T	1044417	9.4	1047431	1.4
MB10NS350	1036501*	1036506	9.0	175	28	US10T	1044426	21.1	1047440	4.1
MB10NS650	1036510*	1036511	9.0	318	32	US10T	1044435	21.1	1047459	4.1
MB12NS150	1036519*	—	10.8	89.8	16	US8AT	1044372	7.9	1047383	1.4
MB12NS200	1036528*	—	10.8	109	19	US8AT	1044381	7.9	1047392	1.4
MB12NS285	1036537*	—	10.8	157	22	US8T	1044404	9.4	1047425	1.4
MB12NS350	1036546*	—	10.8	175	25	US8T	1044417	9.4	1047431	1.4
MB12NS650	1036555*	—	10.8	318	28	US10T	1044426	21.1	1047440	4.1
MB15NS200	1036564*	—	13.5	121	32	US10T	1044435	21.1	1047459	4.1
MB15NS350	1036573*	—	13.5	193						
MB15NS650	1036582*	—	13.5	327						
MB15NS1150	1036591*	—	13.5	581						

\* Utilizes Crosby "N" style hooks with integrated latch. Replacement latch kit is S-4320. PL latch and S-4055 latch will not fit.



UB-500 NON SWIVEL OVERHAUL BALLS



All sizes are RFID EQUIPPED.

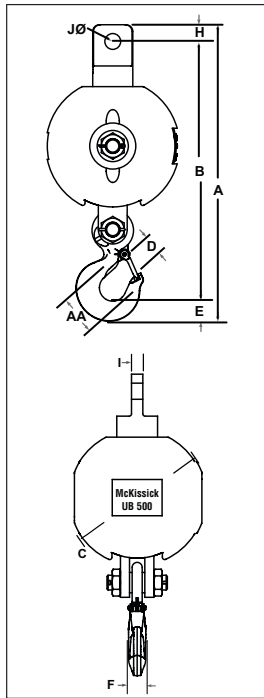

UB-500NS Non Swivel Overhaul Balls with 320N Eye Hooks

Model No.	UB-500NS "E" Stock No.	Dimensions (mm)									
		A	B	C	D	E	F	H	I	J	AA
MB4NS35	1036402	510	439	191	34.5	36.6	28.4	35.1	19.1	33.3	63.5
MB4NS85	1036411	533	461	235	34.5	36.6	28.4	35.1	19.1	33.3	63.5
MB4NS150	1036420	558	487	286	34.5	36.6	28.4	35.1	19.1	33.3	63.5
MB4NS200	1036429	568	496	318	34.5	36.6	28.4	35.1	19.1	33.3	63.5
MB7NS85	1036438	589	517	235	40.9	46.0	35.1	35.1	19.1	33.3	76.0
MB7NS150	1036447	624	543	286	40.9	46.0	35.1	35.1	19.1	33.3	76.0
MB7NS200	1036456	632	551	318	40.9	46.0	35.1	35.1	19.1	33.3	76.0
MB7NS285	1036465	657	576	353	40.9	46.0	35.1	35.1	19.1	33.3	76.0
MB10NS150	1036474	799	691	286	53.0	57.0	41.1	51.0	31.8	45.2	102
MB10NS200	1036483	808	700	318	53.0	57.0	41.1	51.0	31.8	45.2	102
MB10NS285	1036492	832	724	353	53.0	57.0	41.1	51.0	31.8	45.2	102
MB10NS350	1036501	846	738	381	53.0	57.0	41.1	51.0	31.8	45.2	102
MB10NS650	1036510	884	776	456	53.0	57.0	41.1	51.0	31.8	45.2	102
MB12NS150	1036519	799	691	286	53.0	57.0	41.1	51.0	31.8	45.2	102
MB12NS200	1036528	808	700	318	53.0	57.0	41.1	51.0	31.8	45.2	102
MB12NS285	1036537	832	724	353	53.0	57.0	41.1	51.0	31.8	45.2	102
MB12NS350	1036546	846	738	381	53.0	57.0	41.1	51.0	31.8	45.2	102
MB12NS650	1036555	909	776	456	53.0	57.0	41.1	51.0	31.8	45.2	102
MB15NS200	1036564	955	828	318	76.5	76.0	60.5	51.0	31.8	45.2	127
MB15NS350	1036573	986	859	381	76.5	76.0	60.5	51.0	31.8	45.2	127
MB15NS650	1036582	1022	895	456	76.5	76.0	60.5	51.0	31.8	45.2	127
MB15NS1150	1036591	1072	945	549	76.5	76.0	60.5	51.0	31.8	45.2	127

\* 4 ton thru 20 ton models use Crosby "N" style hooks with integrated latch. All sizes are RFID EQUIPPED.

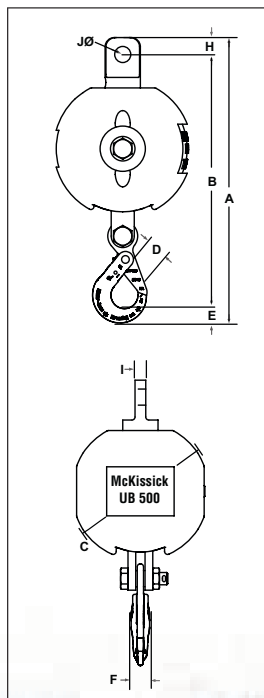

UB-500NS Non Swivel Overhaul Balls with SHUR-LOC® Hooks

Model No.	UB-500NS "S" Stock No.	Dimensions (mm)								
		A	B	C	D	E	F	H	I	J
MB4NS35	1036407	525	462	191	46.5	29.2	23.9	35.1	19.1	33.3
MB4NS85	1036416	547	484	235	46.5	29.2	23.9	35.1	19.1	33.3
MB4NS150	1036425	573	509	286	46.5	29.2	23.9	35.1	19.1	33.3
MB4NS200	1036434	582	519	318	46.5	29.2	23.9	35.1	19.1	33.3
MB7NS85	1036443	607	541	235	53.5	42.2	29.5	35.1	19.1	33.3
MB7NS150	1036452	642	566	286	53.5	42.2	29.5	35.1	19.1	33.3
MB7NS200	1036461	650	575	318	53.5	42.2	29.5	35.1	19.1	33.3
MB7NS285	1036470	675	600	353	53.5	42.2	29.5	35.1	19.1	33.3
MB10NS150	1036479	793	691	286	63.0	52.0	38.1	51.0	31.8	45.2
MB10NS200	1036488	803	700	318	63.0	52.0	38.1	51.0	31.8	45.2
MB10NS285	1036497	827	724	353	63.0	52.0	38.1	51.0	31.8	45.2
MB10NS350	1036506	841	738	381	63.0	52.0	38.1	51.0	31.8	45.2
MB10NS650	1036511	879	776	456	63.0	52.0	38.1	51.0	31.8	45.2

All sizes are RFID EQUIPPED.





**Split Overhaul Ball**

- Attaches easily to Wireline.

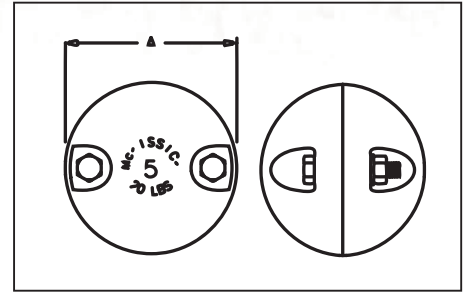

**Split Overhaul Ball**

Catalog No.	Stock No.	Wireline Size (mm)	Weight Each (kg)	Belt Diameter A (mm)
SHB - 15	2003822	6-8	6.80	129
SHB - 20	2003830	10	9.07	137
SHB - 50	2003831	13 - 16	22.7	181
SHB - 100	2003832	16 - 19 - 22	45.4	233



**AS-15 Overhaul Ball**

- Utilize genuine Crosby hooks which are forged alloy steel, Quenched and Tempered and contain the patented **QUIC-CHECK®** marking.
- Entire overhaul ball is zinc plated to resist corrosion.
- Designed with angular contact bearings which maximize efficiency, reliability and service life of swivel and extend the life of the Wireline.
- Available with wide jaw opening that utilizes nylon spools and shields.
- Designed for applications where headroom is critical.
- Other upper fittings available upon request.

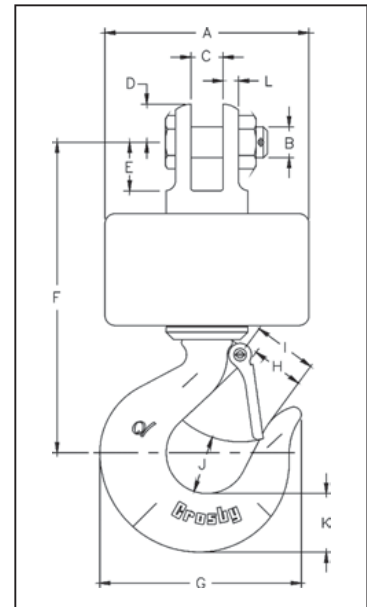

**Angular Contact Bearing Swivel Overhaul Balls**

AS-15 Stock No.	Working Load Limit (t)*	Wire Rope Size (mm)	Dimensions (mm)											Weight Each (kg)	
			A	B	C	D	E	F	G	H	I	J	K		L
2009806	1.36	10	102	12.7	12.7	17.5	19.8	160	104	28.4	31.0	30.2	28.4	7.85	4.08
2009807	2.72	13	127	19.1	19.1	23.9	30.2	217	126	34.0	38.1	35.1	36.6	9.65	8.62
2003969	4.54	16	175	22.4	26.9	28.4	39.6	275	165	42.9	47.8	44.5	46.0	14.2	19.5
2009808	7.71	19	178	30.2	39.6	34.0	53.0	349	221	57.0	63.5	65.0	66.0	13.5	27.2

\* Ultimate Load is 5 times the Working Load Limit.

# McKissick® Overhaul Balls



**UB-550E**  
Overhaul  
Ball

**Top Swivel Design assures that the ball remains stationary if the wireline spins.**

Available in a variety of configurations:

- 4 & 7 Ton capacities
- 85, 150 & 200 lb. weights (ball only)
- Crosby S-320AN Eye Hook or S-1316 SHUR-LOC® Hooks.
- Utilize genuine forged Crosby hooks, bail and connector.
- Quenched and Tempered
- Both styles of hooks incorporate patented **QUIC-CHECK®** markings forged into the product which address two **QUIC-CHECK®** features:
  - Deformation Indicators and Angle Indicators.
- Easy disassembly for periodic inspection and maintenance.
- Design factor of 4:1.
- All sizes are **RFID EQUIPPED**.



**UB-550S**  
Overhaul  
Ball

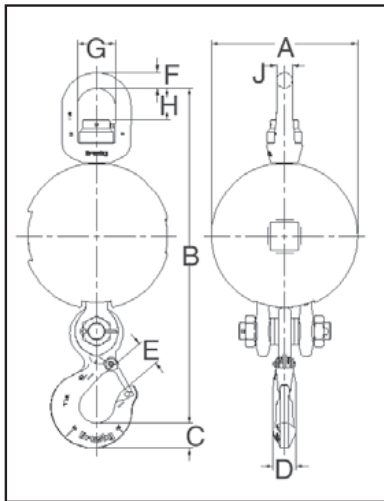

All sizes are RFID EQUIPPED

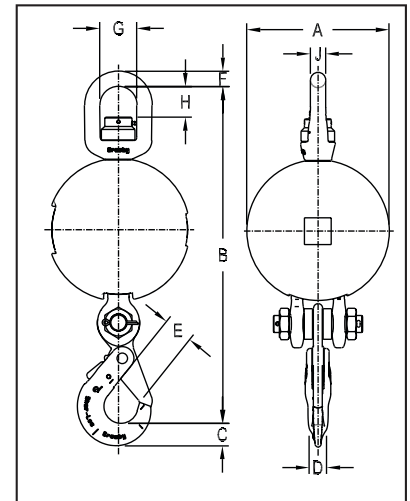

## UB-550E Top Swivel Overhaul Balls with Crosby Eye Hook

UB-550E Stock No.	Model No.	Working Load Limit (t)*	Weight Each (kg)	Dimensions (mm)								
				A	B	C	D	E	F	G	H	J
1036621	MB04BT085E	3.6	51.3	226	533	36.6	33.3	34.5	28.4	69.9	57.9	28.4
1036649	MB04BT150E	3.6	80.7	268	577	36.6	33.3	34.5	28.4	69.9	57.9	28.4
1036667	MB04BT200E	3.6	105	295	602	36.6	33.3	34.5	28.4	69.9	57.9	28.4
1036685	MB07BT085E	6.3	51.3	226	571	46.0	42.2	40.9	28.4	69.9	57.9	28.4
1036705	MB07BT150E	6.3	80.7	268	615	46.0	42.2	40.9	28.4	69.9	57.9	28.4
1036723	MB07BT200E	6.3	105	295	640	46.0	42.2	40.9	28.4	69.9	57.9	28.4

## UB-550S Top Swivel Overhaul Balls with SHUR-LOC® Eye Hook

UB-550S Stock No.	Model No.	Working Load Limit (t)*	Weight Each (kg)	Dimensions (mm)								
				A	B	C	D	E	F	G	H	J
1036630	MB04BT085E	3.6	51.3	226	592	42.4	29.5	53.6	28.4	69.9	57.9	28.4
1036658	MB04BT150S	3.6	80.7	268	636	42.4	29.5	53.6	28.4	69.9	57.9	28.4
1036676	MB04BT200S	3.6	105	295	661	42.4	29.5	53.6	28.4	69.9	57.9	28.4
1036694	MB07BT085S	6.3	51.3	226	592	42.4	29.5	53.6	28.4	69.9	57.9	28.4
1036714	MB07BT150S	6.3	80.7	268	636	42.4	29.5	53.6	28.4	69.9	57.9	28.4
1036732	MB07BT150S	6.3	105	295	661	42.4	29.5	53.6	28.4	69.9	57.9	28.4



# Your Total Block Company

From a 2 ton capacity snatch Block to a 6000 metric ton capacity crane Block, McKissick® can make a block to fit your lifting needs. In the lifting tackle industry, the name McKissick has stood for quality for almost 80 years.



McKissick’s major involvement in the block business came after 1925. At that time, laws were passed requiring safety guards on the WireLine entrance to oilfield blocks. It was McKissick that developed and patented a WireLine guard that could be opened to allow the reeving of the block without disassembly.

Through product diversification, and 100 patents later, McKissick manufactures blocks and sheaves for many market uses including construction, industrial, military, energy and marine applications. From the many “off the shelf” items, to the non-standard “Special Engineered” block and tackle systems, McKissick prides itself on meeting your lifting needs.

McKissick, a part of The Crosby Group LLC since 1959, is not only one of the world’s largest producers of blocks, they also manufacture the world’s largest block and tackle systems. Notable examples of custom blocks manufactured by McKissick include those used to set the NASA space shuttle on the back of the 747 carrier jet.

The largest and most impressive example of McKissick’s capabilities is the M-5000 block (6000 metric ton capacity) for McDermott’s DB-102 derrick barge.

McKissick is an ISO 9001 certified facility. That, in addition to being an API Q1 producer, reinforced McKissick’s, as well as Crosby’s, commitment to continued quality.

McKissick® products, another reason to say:



***“When buying Crosby you’re buying more than product, you’re buying Quality.”***



Licensed Under  
API Spec 8C-0021



[www.thecrosbygroup.com](http://www.thecrosbygroup.com)  
[crosbygroup@thecrosbygroup.com](mailto:crosbygroup@thecrosbygroup.com)



## NEW IMPROVED LIGHT CHAMPION



**418**  
With  
Hook



**419**  
With  
Shackle



**404**  
Tail  
Board

- Forged alloy heat treated hooks.
- Forged steel swivel tees, yokes and shackles.
- Hook and shackle assemblies on 4-1/2" through 14" sizes can be interchanged.
- Can be furnished with bronze bushings or roller bearings.
- Opening feature permits insertion of rope while block is suspended from gin-pole.
- 3" thru 18" 418 and 419 blocks have exclusive bolt-retaining spring to assure no lost bolts.
- Can be furnished with S-4320 hook latch.
- Pressure lube fittings.
- 3" - 10" feature dual rated Wireline sheaves.
- Fatigue rated.
- 4-1/2" and larger are **RFID EQUIPPED**.
- Meets or exceeds all requirements of ASME B30.26 including identification, ductility, design factor, proof load and temperature requirements. Importantly, these blocks meet other critical performance requirements including fatigue life and material traceability, not addressed by ASME B30.26.



### 418 / 419 / 404 Snatch Blocks

Sheave Diameter (mm)	Bearing Code	Stock No.			Wireline Size (mm)	Working Load Limit	Weight Each (kg)			Rep. Sheave Stock No.	Rep. Latch Stock No.
		418 with Hook	419 with Shackle	404 Tail Board			418 with Hook	419 with Shackle	404 Tail Board		
**76.0	BB		109091	—	8-10	2	—	1.90	—	460147	—
**76.0	BB	108038	109037 †	102015	8-10	2	2.04	1.81	1.22	460147	1096421
**114	BB	108065	109064	102025	10-13	4	5.31	5.44	2.99	2000232	1096468
152	BB	108127	109126	102098	16-19	8	12.2	12.6	6.80	460815	1096562
152	RB	108154	109153	102114	16-19	8	12.2	12.6	6.80	472688	1096562
203	BB	108225	109224	102169	16-19	8	15.0	15.4	9.53	461164	1096562
203	RB	108252	109251	102187	16-19	8	15.0	15.4	9.53	473277	1096562
254	BB	108323	109322	102230	16-19	8	18.6	19.1	13.2	461805	1096562
254	RB	108350	109359	102258	16-19	8	18.6	19.1	13.2	473776	1096562
305	BB	169169	202961	178890	16	8	21.8	22.2	16.3	462270	1096562
305	RB	199911	169347	178934	16	8	21.8	22.2	16.3	474141	1096562
305	BB	108421	109420	102301	19	8	21.8	22.2	16.3	462289	1096562
305	RB	108458	109457	102329	19	8	21.8	22.2	16.3	474150	1096562
356	BB	194920	169356	—	16	8	24.9	25.4	—	463625	1096562
356	RB	199948	167857	—	16	8	24.9	25.4	—	474766	1096562
356	BB	108528	109527	—	19	8	24.9	25.4	—	463634	1096562
356	RB	108546	109545	—	19	8	24.9	25.4	—	474775	1096562
406	BB	199975	203041	—	19	15	59	61	—	4100056	1096609
406	RB	200008	203087	—	19	15	59	61	—	4200028	1096609
406	BB	108608	109607	—	22	15	59	61	—	4100065	1096609
406	RB	108626	109625	—	22	15	59	61	—	4200037	1096609
457	BB	200099	203130	—	22	15	68	70	—	464571	1096609
457	RB	200151	203176	—	22	15	68	70	—	475792	1096609
457	BB	108644	109643	—	26	15	68	70	—	4104640	1096609
457	RB	108662	109661	—	26	15	68	70	—	6000000	1096609

\* Ultimate Load is 4 times the Working Load Limit. \*\* Available in Bronze Bushed only. 3" and 4-1/2" have self lubricating Bronze Bushing. † Fitted with 1-1/4" ID Swivel Eye. ‡ May be furnished in other rope sizes.



**NOTE:** When ordering, please specify: size, block number, hook or shackle, bronze bushed or roller bearing, and Wireline size.  
**NOTE:** Tail Board does not contain the spool that is required with the hook (418) and shackle (419) snatch blocks.

**CHAMPION**



**420**  
With  
Hook



**421**  
With  
Shackle



**406**  
Tail  
Board

- Hooks and side plates are forged alloy steel and heat treated.
- Shackles and yokes are forged and heat treated steel.
- All parts are forged.
- Side plates are designed to eliminate possibility of rope jamming.
- Can be furnished with bronze bushings or sealed roller bearings.
- Opening feature permits insertion of rope while block is suspended from gin-pole.
- Can be furnished with S-4320 hook latch.
- Pressure lube fittings.
- Hook and shackle assemblies can be interchanged.
- Blocks furnished with dual rated Wireline sheaves.
- Fatigue Rated.
- All sizes are **RFID EQUIPPED**.
- Meets or exceeds all requirements of ASME B30.26 including identification, ductility, design factor, proof load and temperature requirements. Importantly, these blocks meet other critical performance requirements including fatigue life and material traceability, not addressed by ASME B30.26.

*Fatigue Rated*



**SEE APPLICATION AND WARNING INFORMATION**  
On Pages 381-388  
Para Español: [www.thecrosbygroup.com](http://www.thecrosbygroup.com)

**420 / 421 / 406 Snatch Blocks**

Sheave Diameter (mm)	Bearing Code	Stock No.			Wire Rope Size (mm) †	Working Load Limit (t)*	Weight Each (kg)			Rep. Sheave Stock No.	Rep. Latch Stock No.
		420 with Hook	421 with Shackle	406 Tail Board			420 with Hook	421 with Shackle	406 Tail Board		
152	BB	169374	169481	167973	19-22	12	18.1	21.8	10.9	460940	1096609
152	RB	169392	204120	167982	19-22	12	18.1	21.8	10.9	473035	1096609
203	BB	169418	169515	167991	19-22	15	23.1	25.9	13.6	461360	1096609
203	RB	169445	204193	168008	19-22	15	23.1	25.9	13.6	473534	1096609
254	BB	110221	110720	103186	19-22	15	28.6	31.3	19.1	462001	1096609
254	RB	110258	110757	103202	19-22	15	28.6	31.3	19.1	474025	1096609

\* Ultimate Load is 4 times the Working Load Limit. † May be furnished in other rope sizes.



**NOTE:** When ordering, please specify: size, block number, hook or shackle, bronze bushed or roller bearing, and Wireline size.  
**NOTE:** Tail Board does not contain the spool that is required with the hook (420) and shackle (421) snatch blocks.



## SUPER CHAMPION



**430**  
With  
Hook



**431**  
With  
Shackle



**407**  
Tail  
Board

- Drop forged, heat treated swivel hook or swivel shackle.
- Hook and shackle assemblies on 8" through 14" sizes can be interchanged.
- Can be furnished with bronze bushings or roller bearings.
- Pressure lube fittings.
- 430 and 431 blocks have exclusive bolt-retaining spring to assure no lost bolts.
- Can be furnished with hook latch.
- 8" and 10" models furnished with dual rated Wireline sheaves.
- Fatigue Rated.
- All sizes are **RFID EQUIPPED**.
- Meets or exceeds all requirements of ASME B30.26 including identification, ductility, design factor, proof load and temperature requirements. Importantly, these blocks meet other critical performance requirements including fatigue life and material traceability, not addressed by ASME B30.26.



### 430 / 431 / 407 Snatch Blocks

Sheave Diameter (mm)	Bearing Code	Stock No.			Wire Rope Size (mm)	Working Load Limit (t)*	Weight Each (kg)			Rep. Sheave Stock No.	Rep. Latch Stock No.
		430 with Hook	431 with Shackle	407 Tail Board			430 with Hook	431 with Shackle	407 Tail Board		
203	BB	120023	121022	103523	26-28	20	34.0	39.5	19.1	461440	1096657
203	RB	120041	121040	103541	26-28	20	34.0	39.5	19.1	473614	1096657
254	BB	120096	121095	103603	26-28	20	40.4	45.8	24.9	462083	1096657
254	RB	120112	121111	103621	26-28	20	40.4	45.8	24.9	474105	1096657
305	BB	208536	169917	184375	26	20	46.7	52	31.8	462680	1096657
305	RB	208554	209303	184393	26	20	46.7	52	31.8	474524	1096657
305	BB	120176	121175	103685	28	20	46.7	52	31.8	462699	1096657
305	RB	120194	121193	103701	28	20	46.7	52	31.8	474533	1096657
356	BB	208572	209321	184419	26	20	56	61	40.8	463457	1096657
356	RB	208590	170424	184437	26	20	56	61	40.8	475024	1096657
356	BB	120256	121255	103765	28	20	56	61	40.8	463466	1096657
356	RB	120274	121273	103783	28	20	56	61	40.8	475033	1096657
457	BB	208689	209410	184552	26	25	109	118	75	4100298	1090143
457	RB	208732	209465	184605	26	25	109	118	75	4200331	1090143
457	BB	119482	119561	119641	28	25	109	118	75	4103348	1090143
457	RB	119491	119570	119650	28	25	109	118	75	4200322	1090143
508	BB	208750	209483	184623	28	30	170	181	98	4103936	1090189
508	RB	208787	169864	184650	28	30	170	181	98	4200769	1090189
508	BB	119507	119589	119669	32	30	170	181	98	4103945	1090189
508	RB	119516	119598	119678	32	30	170	181	98	4200778	1090189
610	BB	208812	209526	184687	28	30	204	215	132	4104114	1090189
610	RB	208858	209553	184721	28	30	204	215	132	4200983	1090189
610	BB	119525	119605	119687	32	30	204	215	132	4104123	1090189
610	RB	119534	119614	119696	32	30	204	215	132	4200992	1090189

\* Ultimate Load is 4 times the Working Load Limit. † May be furnished in other rope sizes.

**NOTE:** When ordering, please specify: size, block number, hook or shackle, bronze bushed or roller bearing, and Wireline size. **NOTE:** Tail Board does not contain the spool that is required with the hook (420) and shackle (421) snatch blocks. Contact our Block Hotline (1-800-727-1555) for blocks up to 350 Tons or reference the special request form on page 458



## LIGHT & SUPER CHAMPION DOUBLE SHEAVE



**408 & 432**  
With Hook

- Light champion snatch block as a double sheave block.
- Drop forged swivel hook or swivel shackle.
- Can be furnished with bronze bushings or roller bearings.
- Opening feature permits easy insertion of Wireline in both sheaves with removal of one bolt.
- 408 and 409 can be furnished with S-4320 hook latch.
- 432 and 433 can be furnished with SS-4055 hook latch.
- Pressure lube fittings.
- 4-1/2" - 10" models furnished with dual rated Wireline sheaves.
- Fatigue Rated.
- All sizes are **RFID EQUIPPED**.
- Meets or exceeds all requirements of ASME B30.26 including identification, ductility, design factor, proof load and temperature requirements. Importantly, these blocks meet other critical performance requirements including fatigue life and material traceability, not addressed by ASME B30.26.

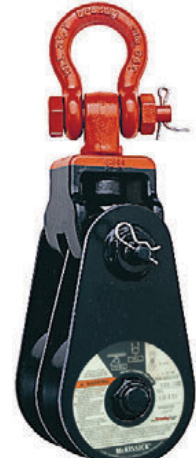

**409 & 433**  
With Shackle

**Fatigue Rated**



### 408 / 409 Light Champion Double Sheave

Sheave Diameter (mm)	Bearing Code	Stock No.		Wireline Size (mm)	Working Load Limit (t)*	Weight Each (kg)		Rep. Sheave Stock No.	Rep. Latch Stock No.
		408 with Hook	409 with Shackle			408 with Hook	409 with Shackle		
114	BB	104023	105022	10-13	4	8.16	8.16	2000232	1096468
152	BB	104103	105102	16-19	12	20.4	22.7	460815	1096609
152	RB	104121	105120	16-19	12	20.4	22.7	472688	1096609
203	BB	104185	105184	16-19	12	24.0	26.3	461164	1096609
203	RB	104201	105200	16-19	12	24.0	26.3	473277	1096609
254	BB	104265	105264	16-19	12	31.8	34.0	461805	1096609
254	RB	104283	105282	16-19	12	31.8	34.0	473776	1096609
305	BB	194578	195185	16	12	40.8	43.1	462270	1096609
305	RB	168044	195229	16	12	40.8	43.1	474141	1096609
305	BB	104345	105344	19	12	40.8	43.1	462289	1096609
305	RB	104363	105362	19	12	40.8	43.1	474150	1096609
356	BB	194621	195247	16	12	45.4	47.6	463625	1096609
356	RB	194649	195265	16	12	45.4	47.6	474766	1096609
356	BB	104425	105424	19	12	45.4	47.6	463634	1096609
356	RB	104443	105442	19	12	45.4	47.6	474775	1096609

\* Ultimate Load is 4 times the Working Load Limit. † Available in Bronze Bushed only. ‡ May be furnished in other Wireline sizes.

### 432 / 433 Super Champion Double Sheave

Sheave Diameter (mm)	Bearing Code	Stock No.		Wireline Size (mm) ‡	Working Load Limit (t)*	Weight Each (kg)		Sheave Diameter (mm)	Bearing Code	Stock No.		Wireline Size (mm) ‡	Working Load Limit (t)*	Weight Each (kg)	
		432 with Hook	433 with Shackle			432 with Hook	433 with Shackle			432 with Hook	433 with Shackle				
203	BB	209624	209811	26	20	48	53	305	BB	209722	209919	26	20	64	69
	RB	209642	209839						RB	209740	209937				
203	BB	122021	123020	28	20	48	53	305	BB	122021	123173	28	20	64	69
	RB	122049	123048						RB	122049	123191				
254	BB	209660	209857	26	20	55	61	356	BB	209660	209955	26	20	86	92
	RB	209697	209884						RB	209697	209973				
254	BB	122094	123093	28	20	55	61	356	BB	122094	123253	28	20	86	92
	RB	122110	123119						RB	122110	123271				

\* Ultimate Load is 4 times the Working Load Limit. † Available in Bronze Bushed only. ‡ May be furnished in other Wireline sizes.



**NOTE:** When ordering, please specify: size, block number, hook or shackle, bronze bushed or roller bearing, and Wireline size.



## ALL ALLOY SNATCH BLOCKS



**416**  
With  
Hook



**417**  
With  
Shackle



**402**  
Tail  
Board

- Entire block made from heat treated alloy steel. Use of heat treated alloy results in a 40% reduction in weight from blocks of comparable capacities.
- Available with a bronze bushed or roller bearing sheaves.
- Easy opening feature of "Champion" blocks retained.
- Hook and shackle assemblies can be interchanged.
- Pressure lube fittings.
- Can be furnished with S-4320 hook latch.
- Blocks furnished with dual rated Wireline sheaves.
- Fatigue Rated.
- Meets or exceeds all requirements of ASME B30.26 including identification, ductility, design factor, proof load and temperature requirements. Importantly, these blocks meet other critical performance requirements including fatigue life and material traceability, not addressed by ASME B30.26.
- All sizes are **RFID EQUIPPED**.

**Fatigue Rated**



**SEE APPLICATION AND WARNING INFORMATION**  
On Pages 381-388  
Para Español: [www.thecrosbygroup.com](http://www.thecrosbygroup.com)

### 416 / 417 / 402 Alloy Snatch Blocks

Sheave Diameter (mm)	Bearing Code	Stock No.			Wireline Size (mm) †	Working Load Limit (t)*	Weight Each (kg)			Rep. Sheave Stock No.	Rep. Latch Stock No.
		416 with Hook	417 with Shackle	402 Tail Board			416 with Hook	417 with Shackle	402 Tail Board		
152	BB	193427	168972	179238	19-22	12	11.8	12.20	6.80	460824	1096609
152	RB	193472	193757	179283	19-22	12	11.8	12.20	6.80	472679	1096609
203	BB	193490	168990	179318	19-22	12	15.0	15.40	9.50	461173	1096609
203	RB	193542	193819	179363	19-22	12	15.0	15.40	9.50	473286	1096609
254	BB	193613	193882	179434	19-22	12	18.6	19.10	13.20	461814	1096609
254	RB	193677	193935	179498	19-22	12	18.6	19.10	13.20	473785	1096609

\* Ultimate Load is 4 times the Working Load Limit. † May be furnished in other Wireline sizes.



**NOTE:** When ordering, please specify: size, block number, hook or shackle, bronze bushed or roller bearing, and Wireline size.  
**NOTE:** Tail Board does not contain the spool that is required with the hook (416) and shackle (417) snatch blocks.

**ALL ALLOY HIGH CAPACITY SNATCH BLOCKS**



**434**  
With  
Hook



**435**  
With  
Shackle



**401**  
Tail  
Board

- Entire block made from heat treated alloy steel. Use of heat treated alloy results in a 40% reduction in weight from blocks of comparable capacities.
- Available with bronze bushed sheaves.
- Easy opening feature of “Champion” blocks retained.
- Pressure lube fittings.
- Can be furnished with hook latch.
- Fatigue Rated.
- Meets or exceeds all requirements of ASME B30.26 including identification, ductility, design factor, proof load and temperature requirements. Importantly, these blocks meet other critical performance requirements including fatigue life and material traceability, not addressed by ASME B30.26.
- All sizes are **RFID EQUIPPED**.

**Fatigue Rated**



**SEE APPLICATION AND WARNING INFORMATION**  
On Pages 381-388  
Para Español: [www.thecrosbygroup.com](http://www.thecrosbygroup.com)

**434/ 435 / 401 Snatch Blocks**

Sheave Diameter (mm)	Bearing Code	Stock No.			Wireline Size (mm) ‡	Working Load Limit (t)*	Weight Each (kg)		
		434 with Hook	435 with Shackle	401 Tail Board			434 with Hook	435 with Shackle	401 Tail Board
203	BB	208894	168295	179149	25	25	41	46	23
203	BB	302522	302568	302602	28	25	41	46	23
254	BB	208901	208956	179158	25	25	49	54	29
254	BB	208910	208965	179167	32	25	49	54	29
254	BB	302531	302577	302611	28	25	49	54	29
305	BB	208929	208974	179176	25	30	75	83	43
305	BB	302540	302586	302620	28	30	75	83	43
356	BB	208938	208983	179185	25	30	82	90	50
356	BB	302559	302595	302639	28	30	82	90	50
305	BB	-	8027291	8027292	28	60	-	143	73

\* Ultimate Load is 4 times the Working Load Limit. ‡ May be furnished in other Wireline sizes.



**NOTE:** When ordering, please specify: size, block number, hook or shackle, bronze bushed or roller bearing, and Wireline size.  
**NOTE:** Tail Board does not contain the spool that is required with the hook (434) and shackle (435) snatch blocks.

For custom orders contact our Block Hotline (1-800-727-1555) or reference the special request form on page 485.





## HEAVY DUTY SNATCH BLOCKS



L-5-H



L-5-S



L-5-T

- Hook is Forged Alloy Steel – Quenched and Tempered.
- Designed for fast, efficient line changes.
- All parts are forged.
- Beaded side plate prevents rope from jamming.
- Available with hook, shackle or tail board (pin only).
- Can be furnished with hook latch.
- Blocks furnished with dual rated Wireline sheaves.
- Fatigue Rated.
- Meets or exceeds all requirements of ASME B30.26 including identification, ductility, design factor, proof load and temperature requirements. Importantly, these blocks meet other critical performance requirements including fatigue life and material traceability, not addressed by ASME B30.26.



### L-160 Series Heavy Duty Snatch Blocks

Block No.	Bearing Code	L-160 Stock No.	Fitting	Sheave Diam. (mm)	Working Load Limit (t)*	Wireline Size (mm)	Weight Each (kg)	Rep Sheave Stock No.	Rep. Latch Stock No.
L-5-H	BB	599506	Hook	127	6	10-13	6.94	592095	1096468
L-5-H	RB	599515	Hook	127	6	10-13	6.94	592157	1096468
L-5-S	BB	599524	Shackle	127	6	10-13	6.80	592095	-
L-5-S	RB	599533	Shackle	127	6	10-13	6.80	592157	-
L-5-T	BB	599542	Tailboard	127	6	10-13	4.54	592095	-
L-5-T	RB	599551	Tailboard	127	6	10-13	4.54	592157	-
L-6-H	BB	599560	Hook	149	12	16-19	14.4	592175	1096609
L-6-H	RB	599579	Hook	149	12	16-19	14.4	592255	1096609
L-6-S	BB	599588	Shackle	149	12	16-19	13.6	592175	-
L-6-S	RB	599597	Shackle	149	12	16-19	13.6	592255	-
L-6-T	BB	599604	Tailboard	149	12	16-19	8.07	592175	-
L-6-T	RB	599613	Tailboard	149	12	16-19	8.07	592255	-

\* Ultimate Load is 4 times the Working Load Limit.



NOTE: When ordering, please specify: size, block number, hook or shackle, bronze bushed or roller bearing, and Wireline size.  
NOTE: Tail Board does not contain the spool that is required with the hook (L-5-H) and shackle (L-5-S) snatch blocks.

## GENERAL PURPOSE SNATCH BLOCKS



L-45-H



L-45-S



L-45-T

- Hook is Forged Alloy Steel – Quenched and Tempered.
- Shackle is Forged Alloy Steel – Quenched and Tempered.
- All parts are forged.
- Opened and closed in seconds without the use of tools.
- Available with hook, shackle or tail board (pin only).
- Either wire or manila rope may be used.
- Can be furnished with hook latch.
- Blocks furnished with dual rated Wireline sheaves.
- Meets or exceeds all requirements of ASME B30.26 including identification, ductility, design factor, proof load and temperature requirements. Importantly, these blocks meet other critical performance requirements including fatigue life and material traceability, not addressed by ASME B30.26.



### L-170 Series General Purpose Snatch Blocks

Block No.	Bearing Code	L-170 Stock No.	Fitting	Sheave Diam. (mm)	Working Load Limit (t)*	Wireline Size (mm)	Manila Rope Size (mm)	Weight Each (kg)	Rep Sheave Stock No.	Rep. Latch Stock No.
L-45-H	BB	599800	Hook	105	5	10-13	32	5.90	460405	1096468
L-45-H	RB	599819	Hook	105	5	10-13	32	5.90	472580	1096468
L-45-S	BB	599828	Shackle	105	5	10-13	32	5.90	460405	-
L-45-S	RB	599837	Shackle	105	5	10-13	32	5.90	472580	-
L-45-T	BB	599846	Tail Board	105	5	10-13	32	4.08	460405	-
L-45-T	RB	599855	Tail Board	105	5	10-13	32	4.08	472580	-

\* Ultimate Load is 4 times the Working Load Limit.



**NOTE:** When Ordering, specify either roller bearing or bronze bushed sheaves.  
**NOTE:** Tail board does not contain the spool that is required with the hook (L-45-H) and shackle (L-45-S) snatch blocks.



**C-700**  
Snatch Block

- Unique locking device permits disengagement by simply folding hook.
- Formed steel side plates with capacity stamped permanently in place.
- Self-Lubricating bronze bushings.
- Can be furnished with S-4320 hook latch.
- Furnished with dual rated Wireline sheaves.

**C-700 General Purpose Snatch Blocks**

Sheave Diam. (mm)	Block No.	C-700 Stock No.	Working Load Limit (t)*	Wireline Size (mm)	Weight Each (kg)	Fitting	Rep. Latch Stock No.
152	10611	260014	2	10-13	5.44	Swivel Hook	1096468
203	10811	261013	3	13-16	8.44	Swivel Hook	1096515

\* Ultimate Load is 3.5 times the Working Load Limit.



**C-720**  
Snatch Block

- Forged steel sheaves, bronze bushings.
- Drop forged steel hook.
- Pressure lube fitting.
- Self-locking style. Locks with hook load.
- Can be furnished with S-4320 hook latch.
- Furnished with dual rated Wireline sheave.

**C-720 Heavy Duty Utility Snatch Blocks**

Sheave Diam. (mm)	Block No.	C-720 Stock No.	Working Load Limit (t)*	Wireline Size (mm)	Weight Each (kg)	Fitting	Rep. Latch Stock No.
152	60611	280010	6.35	19-22	12.7	Swivel Hook	1096562

\* Ultimate Load is 3.5 times the Working Load Limit.



**C-720**  
Toggle Block

- Forged steel sheaves, bronze bushings.
- Pressure lube fitting.
- Furnished with dual rated Wireline sheave.

**C-720 Toggle Blocks (Tail Board)**

Sheave Diam. (mm)	Block No.	C-720TB Stock No.	Working Load Limit (t)*	Wireline Size (mm)	Weight Each (kg)	Fitting
152	70610	290018	6.35	19-22	9.53	Tail Board

\* Ultimate Load is 3.5 times the Working Load Limit.





## HAY FORK PULLEYS



HF-1

- Forged steel eyes and hooks.
- Available Painted or Zinc Plated.
- One piece pressed steel shells.
- Edges well rounded to prevent chaffing of rope.
- Can be furnished with SS-4320 hook latch.
- Furnished with roller bearings.
- Pressure lube fittings.



HF-2

### HF-1 / HF-2 Hay Fork Pulleys with Swivel Hook or Swivel Eye

Sheave Diameter (mm)	Block No.	Hay Fork Pulleys Stock No.		Working Load Limit (t)*	Standard Rope Size (mm)	End Fitting	Weight Each (kg)
		Painted	Zinc Plated				
114	HF-1	170022	170594	.91	32 MR	Swivel Hook	2.72
114	HF-2	170086	170629	.91	32 MR	Swivel Eye	2.72
114	HF-3	170148	170656	.91	13 WR	Swivel Hook	2.72
114	HF-4	170200	170683	.91	13 WR	Swivel Eye	2.72
203	HF-5	170264	-	1.81	13 WR	Swivel Eye	4.99
152	HF-11	170380	-	1.81	38 MR	Swivel Hook	4.99
152	HF-12	170442	-	1.81	38 MR	Swivel Eye	4.99
152	HF-13	170503	-	1.81	16 WR	Swivel Hook	4.99
152	HF-14	170567	-	1.81	16 WR	Swivel Eye	4.99

\* Ultimate Load is 4 times the Working Load Limit. Rope Code: MR - Manila Rope, WL - Wireline.



171  
Tong Block

- Steel sheaves with roller bearings and pressure lubrication.
- Forged steel eyes and hooks.
- Easy opening feature shown available in 303mm size only.



### 171 Tong Block

Sheave Diameter (mm)	Block No.	171 Stock No.	Working Load Limit (t)*	Wireline Size (mm)	Weight Each (kg)	Connection
152	TB-1	171012	.45	19	4.99	Swivel Eye
203	TB-1	171058	.91	19	5.44	Swivel Eye
254	TB-1	171101	2.27	19	13.6	Swivel Eye
305	TB-1	171156	2.27	19	15.9	Swivel Eye

\* Ultimate Load is 4 times the Working Load Limit.



443  
Lay Down Block

- All steel construction, steel sheaves mounted on antifriction bearings, grooved for maximum of 3/4" Wireline.
- Used to lay down drill pipe.
- Hook made to fit into end of drill pipe, handy dead end becket for returning block – hooks have handle for disengagement.

### 443 Lay Down Block

Sheave Diameter (mm)	Block No.	443 Stock No.	Working Load Limit (t)*	Wireline Size (mm)	Weight Each (kg)	Type Block
114	443	171414	.23	13	5.44	Regular
152	443	171432	.45	19	7.71	Regular

\* Ultimate Load is 4 times the Working Load Limit.



**M-491**  
Tower Hoist Block

**New design provides the dependability of standard McKissick® Snatch Blocks, along with features that make it perfect for the challenging needs of Tugger Hoist and Tower Erection applications.**

- A wide variety of configurations:
  - 4, 8, 12, 15, 25 or 30 metric ton capacity
  - 10, 13, 16, 19, 22, 25 and 32mm Wireline sizes
  - Painted or Galvanized finish
- 203mm and 254mm blocks furnished with dual rated Wireline sheaves.
- Forged steel swivels, tees, yokes and shackles are Quenched & Tempered.
- Sheave lubrication through center pin for easy maintenance.
- Design factor of 4 to 1.
- All blocks 356mm and larger are furnished with McKissick® Roll Forged sheaves with flame hardened grooves.
- Recessed sideplate design reduces the gap between the sheave rim and the sideplate, allowing the sheave assembly to be captured in the block if loss of center pin occurs.
- Sealed tapered roller bearings extend the life of the center pin and bearings, and allows for faster line speeds than recommended with standard snatch blocks.
- Shackle fitting swivels for easy positioning.
- Suitable for hoisting personnel, contingent upon all employees, including the winch operator, being trained to follow applicable Federal, local and industry standards.
  - Tugger/Derrick applications: API RP54
  - Tower applications: OSHA directive CPL 2-1.36
- Holes through side plates are available for secondary block securement device.
- Manufactured by an API Q1 Certified facility.
- Type Approval and certification in accordance with ABS 2006 Steel Vessel Rules 1-1-17.7, and ABS Guide for Certification of Cranes.
- All sizes are **RFID EQUIPPED**.



**M-491G**  
Derrick Hoist Block



## M-491 / M-491G Tower/Derrick Hoist Blocks

Working Load Limit (t)*	Sheave Diameter (mm)	Wireline Size (mm)	M-491S Stock No. Painted	M-491G Stock No. Galvanized	Weight Each (kg)
4	203	10 - 13	2020151	2020170	16
8	254	10 - 13	2020806	2020815	25
8	254	13 - 14	2020824	2020833	25
12	254	13 - 14	2021118	2021127	25
12	356	16	2021136	2021145	43
12	356	19	2021154	2021163	43
15	406	22	2021172	2021181	68
15	406	25	2021190	2021199	48
25	457	28.6	2032312	2032315	118
30	508	32	2032321	2032324	306

\* Ultimate Load is 4 times the Working Load Limit.

Contact our our Block Hotline (1-800-727-1555) for larger blocks up to 350 tonnes or reference the special request form on page 485.



**70 Series**  
Blocks

**McKissick® Oilfield Tubing Blocks utilizing new Split Nut Retention System. Revolutionary new retention system eliminates conventional threaded nut and potential problems associated with thread corrosion.**

- Exclusive E-Z opening guards, no bolts to pull out and lose. Feature gives fastest possible exposure of sheave cluster for quick reeving.
- Extremely short overall length, extra weight, excellent balance for fast non-wobbling falls.
- Roller thrust bearing in hook.
- Duplex hook for easy elevator operation, locks in eight positions.
- Also available with Rod Hook Clevis.
- Completely streamlined, no projections.
- McKissick Roll-Forged, flame hardened sheaves, grooved to API profile for proper Wireline size. Contact Crosby for additional Wireline sizes.
- Separate lubrication channel to each sheave.
- Double row, pre-adjusted tapered bearings with seals.
- McKissick Split-Nut® hook parts precision machined and individually fitted for maximum performance.
- Manufactured to API-8C specifications.
- 35 ton Capacity Rod Hook Clevis available.
- Lock Arms with Self Retaining Bolts.
- All sizes are **RFID EQUIPPED**.
- The 70 Series has a spring loaded hook that is better for heavy usage and larger depths. Tends to last longer since the shock loads are somewhat absorbed.
- The 80 Series has no spring loaded hook and is better for shallow depths and rework.



**80 Series**  
Blocks



Licensed Under  
API Spec 8C-0021

**Fatigue Rated**



## 70 Series Tubing Blocks

Stock No.	Block Config.*	Working Load Limit (t)	Rod Hook Clevis Working Load Limit (t)	Wireline Size (mm)	Weight Each (kg)
111895	20" 73-A**	68	11	22	823
111823	24" 73	90	18	25	1195
111921	24" 73-A**	90	18	25	1247
111922	24" 73-AN**	113	31	25	1263
128798	30" 74	135	20	28	1996
125550	30" 74-A**	135	20	28	2024
112552	30" 74-AN**	158	31	28	2251

\* Spring loaded duplex hook assuring ample travel for efficient tubing operations. No load carrying threads \*\* A = Rod Hook Clevis attachment standard. AN = New 35 Ton Clevis.

## 80 Series Tubing Blocks

Stock No.	Block Config.	Working Load Limit (t)	Rod Hook Clevis Working Load Limit (t)	Wireline Size (mm)	Weight Each (kg)
112135	17" 83	45	6.8	22	491
112243	17" 83-A**	45	6.8	22	503
112252	20" 82-A**	45	6.8	22	564
112261	20" 83-A**	68	11	22	753
112270	24" 82-A**	68	11	25	830
112181	24" 83	90	18	25	998
112279	24" 83-A**	90	18	25	991
117498	24" 84-A**	90	18	25	1247
112278	24" 83-AN**	113	31	25	996
117500	24" 84-AN**	113	31	25	1329
117514	30" 84-A**	135	20	28	1873
205857	30" 83-AN**	158	31	28	1704
117516	30" 84-AN**	158	31	28	1963

\*\* A = Rod Hook Clevis attachment standard. AN = New 35 Ton Clevis.





## WELL LOGGER'S BLOCKS



**475**  
Floor Block



**477**  
Floor Block



**476**  
Top Block

- Alloy aluminum housing for maximum strength and minimum weight.
- Conductor cable ONLY is recommended for use with Well Logger's Blocks.
- For use in high speed well logging, perforating, etc.
- Extra large double row, pre-adjusted sealed tapered bearing.
- Quick opening pin for fast string-up, light weight for easy handling.



### 475 / 477 Floor Blocks

Sheave Diam. (mm)	Block No.	Floor Block Stock No.	Working Load Limit (t)*	Conductor Cable Size (mm)†	Weight Each (kg)	Connection
178	475	180020	1.35	5	4.5	Swivel Hanger
254	475	180128	1.35	5	5.0	Swivel Hanger
254	475	180253	2.25	8	9.5	Swivel Hanger
305	475	180440	2.25	8	10.8	Swivel Hanger
356	475	180618	2.25	8	19.5	Swivel Hanger
356	477	169784	5.4	6	26.3	Swivel Clevis
508	477	191072	5.4	6	31.8	Swivel Clevis
610	477	191107	9.0	8	58.9	Swivel Clevis

\* Ultimate Load is 4 times the Working Load Limit.

† Other cable sizes available upon request.

### 476 Top Blocks

Sheave Diam. (mm)	Block No.	Top Block Stock No.	Working Load Limit (t)*	Conductor Cable Size (mm)	Weight Each (kg)	Connection
178	476	180075	2.25	5	4.5	Stinger Pin
254	474	180173	2.25	5	4.5	Stinger Pin
254	476	180333	3.6	8	9.5	Stinger Pin
305	476	180529	3.6	8	10.8	Stinger Pin
356	476	180707	3.6	8	19.5	Stinger Pin

\* Ultimate Load is 4 times the Working Load Limit.

## McKissick® Oilfield Servicing Blocks



**731**  
Crown Block

- McKissick Roll-Forged sheaves with flame hardened grooves.
- Double row pre-adjusted sealed tapered bearings mounted on a steel shaft.
- Heavy center and side plates for proper support of center pin.
- Pre-assembled units for rapid attachment to crown assembly for installation on derrick.
- On multiple sheave assemblies, one sheave can be grooved for sand line on request.
- Other sizes available upon request.
- Sheaves manufactured to API-8C specifications.



### Crown Blocks

Sheave Diam. (mm)	Block No.	Crown Block Stock No.	No. of Sheaves	Working Load Limit (t)	Standard Wireline Size (mm)*	Weight Each (kg)
610	241	351158	1	13.5	22	91
610	242	351167	2	27	22	126
610	243	351176	3	40.5	22	170
610	731	351185	1	31.5	25	91
610	732	351194	2	67.5	25	159
610	733	351201	3	90	25	238
610	734	351210	4	113	25	327
762	741	351229	1	36	28	147
762	742	351238	2	72	28	254
762	743	351247	3	99	28	363
762	744	351256	4	126	28	445
762	745	351265	5	153	28	528

\* May be furnished in other Wireline sizes.



## API 2C Block Systems

Block Systems for Offshore pedestal mounted cranes certified to API 2C are considered critical components. McKissick provides blocks, overhaul balls, sheaves and wedge sockets that meet the critical component requirements of API 2C to required CV value.

(It is the responsibility of the crane manufacturer to license or certify these components.)



Reference page 486 to assist in proper specification.

# McKissick® Oilfield Drilling Blocks



**RJ Style  
Drilling Block**

- Capacities Available: 150, 250 & 350 Tons.
- Double row, pre-adjusted tapered bearings with seals.
- Blocks contain McKissick® Roll-Forged sheaves with flame hardened grooves.
  - Grooves are API profile
- Separate lubrication channel to each sheave.
- Easy opening guards for quick string-up (no bolts to pull out and lose).
- Each hook block is fitted with position lock and swivel lock assemblies.
- Additional weights available upon request.
- Manufactured to the requirements of API 8C, including all documentation.
  - Each block is individually serialized for full traceability.
  - Furnished with Certificate of Conformance.
- Hook is spring loaded with hydraulic snubber.
- Minimum design temperature of -20 degree C (-4 degree F).
- Standard top coat finish is safety orange enamel.
  - Other paint colors and systems are available on request.
  - Individual parts are primer coated on exposed surfaces.
- Combination hook blocks have interchangeable parts with BJ type McKissick® blocks built up to 1982.
  - Contact Crosby Customer Service for details.
- All sizes are **RFID EQUIPPED**.

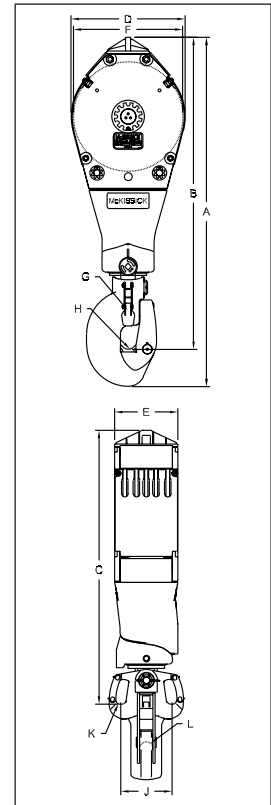

Licensed Under  
API Spec 8C-0021



## RJ Style Drilling Blocks

Model No.	RJ Block Stock No.	Working Load Limit (t)	Sheave Diam. (mm)	No. of Sheaves	Standard Wire Rope Size (mm)*	Dimensions (mm)											Weight Each (kg)
						A	B	C	D	E	F	G	H	J	K	L	
864	2028185	136	762	4	28	2973	2629	2261	826	514	762	60.5	76.2	508	51.0	108	2944
865	2028194	136	914	4	28	3089	2746	2378	978	559	914	60.5	76.2	508	51.0	108	3837
866	2028203	136	914	5	28	3089	2746	2378	978	679	914	60.5	76.2	508	51.0	108	4377
868	2024318	227	914	5	28	3288	2926	2554	965	616	914	95.3	82.5	502	47.8	102	4762
869	2024317	227	1067	5	28	3440	3078	2707	1118	616	1067	95.3	82.5	502	47.8	102	4990
870	2024301	318	1067	5	32	3747	3366	2883	1118	616	1067	95.3	82.5	559	63.5	102	5761

\* Additional Wireline sizes are available.

**McKISSICK® BLOCKS**





**RP Style**  
Traveling  
Block

**RJ Style Traveling Blocks**

- Capacities Available: 250, 350, 500, 750 and 1000 Tons
- Double row, pre-adjusted tapered bearings with seals.
- Blocks contain McKissick® Roll-Forged sheaves with flame hardened grooves.
  - Grooves are API profile.
- Separate lubrication channel to each sheave.
- Bail design to adapt to comparable capacity drilling equipment.
- Additional weights available upon request.
- Manufactured to the requirements of API 8C, including all documentation.
  - Each block is individually serialized for full traceability.
  - Furnished with Certificate of Conformance.
- Minimum design temperature of -20 degree C (-4 degree F).
- Standard top coat finish is safety orange enamel.
  - Other paint colors and systems are available on request.
  - Individual parts are primer coated on exposed surfaces.
- Block side plates can be drilled to adapt customer supplied equipment.
- Easy bail pin removal.
- All sizes are **RFID EQUIPPED**.

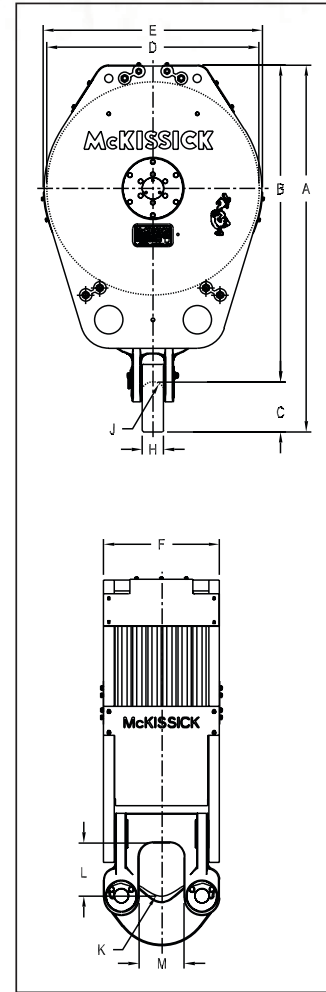

**RP Style Traveling Blocks**

RP Block Stock No.	Working Load Limit (t)	Sheave Diam. (mm)	No. of Sheaves	Standard Wireline Size (mm)*	Dimensions (mm)											Weight Each (kg)
					A	B	C	D	E	F	H	J	K	L	M	
2031027	250	914	5	32	1880	1600	279	914	991	616	127	63.5	88.9	276	202	2540
2032319	250	1067	5	28	2032	1753	279	1067	1118	616	127	63.5	88.9	276	202	3198
2029783	350	1067	5	32	2032	1753	279	1067	1118	616	127	63.5	88.9	276	202	3243
2031434	350	1067	6	32	2032	1753	279	1067	1118	711	127	63.5	88.9	276	202	3537
2029735	500	1524	6	35	2496	2140	356	1524	1562	832	152	88.9	102	381	324	7303
2029761	750	1524	7	38	2724	2343	381	1524	1562	991	229	114	127	470	432	9886
2032326	1000	1829	8	44	3232	2775	457	1829	1880	1226	229	127	159	502	540	17463

\* Additional Wireline sizes are available.



**458**  
Guy Line  
Block

## Guy Line Blocks

- Used on guy lines to gain mechanical advantage through rapid take-up, taking less pull to guy down.
- Laser burned steel side plates, cold-finished steel pins, 6" steel sheaves.



**459**  
Guy Line  
Block



## Guy Line Blocks

Block No.	No. of Sheaves	Stock No.	Working Load Limit (t)	Sheave Diameter (mm)	Standard Wireline Size (mm)*	Weight Each (kg)
458	1	171619	4.5	152	13	9.5
458H	1	239067	7.2	152	14-16	11.3
459	2	171637	9	152	13	12.7
459H	2	239076	10.8	152	14-16	14.1

\* May be furnished in other Wireline sizes.



**TGRB**  
Tubing Grab

- Designed to lift tubing from horizontal to vertical and back.
- Engages with upset end of tubing.
- Available in two sizes:
  - 60.3 tubing
  - 73.0 tubing
- Repair kit (8037937) includes springs and retaining clip.
- Fitted with 3/8" G-2130 Crosby Shackle for attachment to air tugger line.
- Secondary eye provided for attachment of tag line.
- Individually proof tested to 125% Working Load Limit.
- Standard finish is zinc plated.
- Patented.

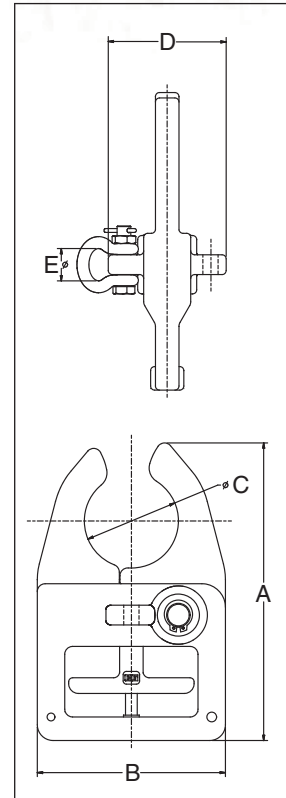

Scan this QR code with your smart device to view our product brochure.



**TGRB Tubing Grab**

Size (mm)	TGRB Stock No.	Working Load Limit* (kg)	Dimensions (mm)					Weight Each (kg)
			A	B	C	D	E	
60.3	2734950	227	241	152	63.5	95.5	26.2	5
73.0	2734949	227	241	152	76.2	95.5	26.2	5

\* 10:1 design factor.



Revolutionary

## Split-Nut® Retention System

*Innovative Split-Nut design provides many benefits to selected blocks*

- ✓ Eliminates conventional threaded nut and problems associated with nut removal for inspection.
- ✓ Allows for easy inspection as required by API RP-8B and specific crane standards.
- ✓ Allows repeated installation and removal without risk of damage to hook/nut interface.
- ✓ Redundant secured and sealed fasteners (Tubing block version).
- ✓ Can be purchased in a variety of configurations that can be used to retro-fit selected McKissick® blocks – in the field or in the shop.
  - Hook and nut assembly that fits existing 80 Series cases.
  - Hook and case assembly that bolts into existing block.
  - Hook and Trunnion assembly that replaces existing hook and trunnion in crane blocks.
- ✓ Fatigue Rated

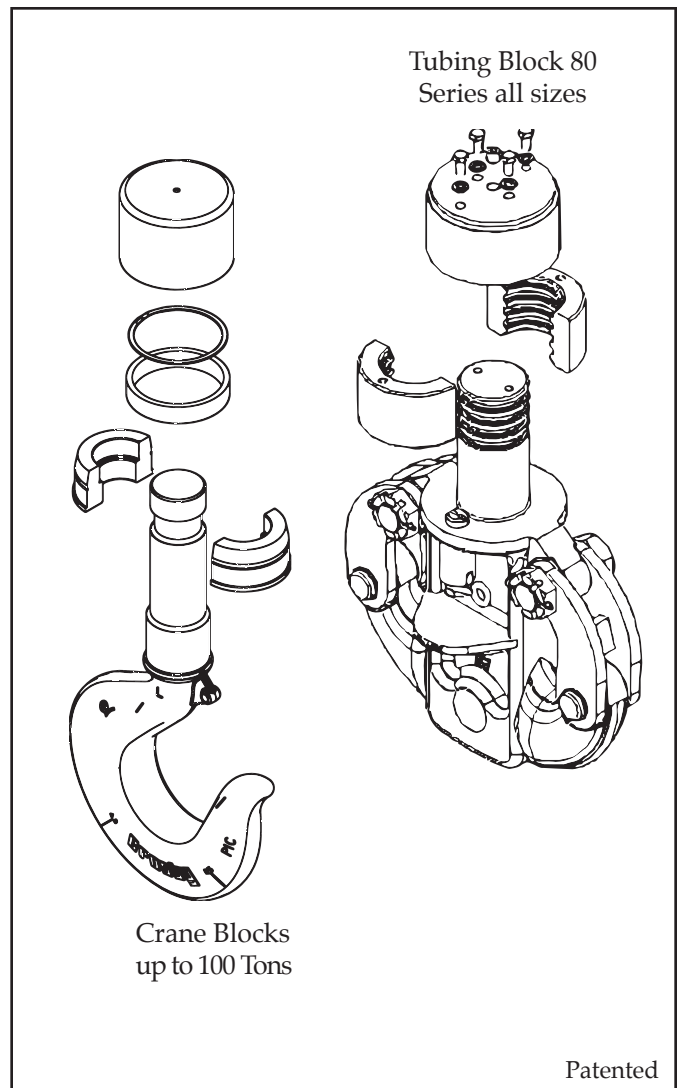

Patented

**Fatigue Rated**



Licensed Under  
API Spec 8C-0021

# Crosby®

(918) 834-4611

[www.thecrosbygroup.com](http://www.thecrosbygroup.com)

[crosbygroup@thecrosbygroup.com](mailto:crosbygroup@thecrosbygroup.com)

**T**hese seminar and support materials were developed for the Crosby product line. The materials are intended to be used as classroom references in training sessions conducted by Authorized Crosby Instructors. Crosby provides instruction only on how to use the material. Crosby does not select or determine whether each attendee is qualified to be a trainer. The management of companies requesting the Crosby training is responsible for determining the capability and suitability of all trainers in their employment.

## API RP-2D Rigging Training Development Course (For Offshore Environments)

**Those who attend Day One, Course #OE-001 will receive:**

- Certificate of Completion
- A Crosby Workbook API RP-2D
- Crosby's API Users Guide for Lifting laminated pocket reference guide

**Those who attend the full two-day program, Course #OE-003, will receive:**

- Same materials as shown above, plus:
- Crosby General Catalog on DVD
- Crosby API CD Lift Guide (Computer Based Course)
- The ability to receive a "Crosby Authorized Trainer" certificate valid for four years
- A CD with PowerPoint files for a 4-to-37 hour rigging presentation
- The ability to order Crosby training materials at reduced prices
- Can earn "CEU" credits

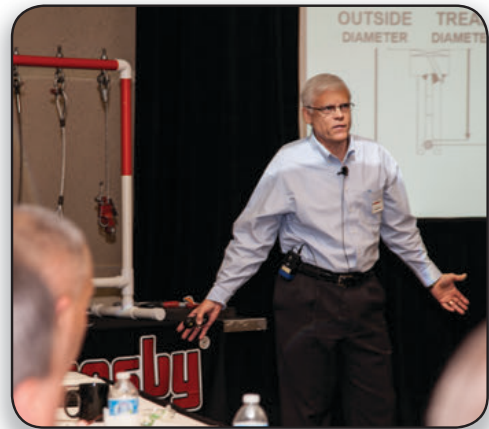

## Land Based Energy Operations Rigging Training Development Course

**Those who attend Day One, Course #LB-001 will receive:**

- Certificate of Completion
- A Crosby Seminar Workbook: Land Based Energy Operations, Edition 1
- Crosby's Land-Based Users Guide for Lifting laminated pocket reference guide

**Those who attend the full two-day program, Course #LB-001 and #LB-003, will receive:**

- Same materials as shown above
- Crosby General Catalog on DVD
- Crosby CD Lift Guide (Computer Based Course)
- The ability to receive a "Crosby Authorized Trainer" certificate valid for four years
- A CD with PowerPoint files for a 7 to 9 hour rigging presentation
- The ability to order Crosby training materials at reduced prices
- Can earn "CEU" credits



## ASME/OSHA Rigging Training Development Course

**Those who attend day one, Course CA-005 will receive:**

- Certificate of Completion
- A Crosby Rigging Workbook : Edition 7 Trainers Workbook
- Crosby ASME Users Guide for Lifting laminated pocket reference guide

**Those who attend the full two day program, Course CA-005 and CA-006**

- Same materials as shown above, plus
- Crosby General Catalog on DVD
- Crosby CD Lift Guide (Computer Based Course)
- Crosby / McKissick Block Selection and Application DVD
- Crosby IP Clamps Selection and Application DVD
- A CD with PowerPoint files for a 4-to-7 hour rigging presentation
- The ability to receive a "Crosby Authorized Trainer" certificate valid for four years
- A CD-Rom with PowerPoint files for a 7-to-9 hour rigging presentation
- The ability to order Crosby training materials at reduced prices
- Can earn "CEU" credits



Classroom training is only a small part of the needed qualifications. Demonstrated ability on the job is equally important. Once the certificate request form is signed by a supervisor or manager and all requirements are met, we will send a certificate authorizing you to use Crosby training materials for 48 months.



# TACKLE BLOCK & SHEAVE ASSEMBLY

## WARNINGS, USE AND MAINTENANCE INFORMATION

### WARNING

- A potential hazard exists when lifting or dragging heavy loads with tackle block assemblies.
- Failure to design and use tackle block systems properly may cause a load to slip or fall – the result could be serious injury or death.
- Failure to design lifting system with appropriate sheave assembly material for the intended application may cause premature sheave, bearing or Wireline wear and ultimate failure - the result could be serious injury or death.
- A tackle block system should be rigged by a qualified person as defined by ANSI/ASME B30.26.
- Instruct workers to keep hands and body away from block sheaves and swivels – and away from “pinch points” where rope touches block parts or loads.
- Do not side load tackle blocks.
- See OSHA Rule 1926.1431(g)(1)(i)(A) and 1926.1501(g)(4)(iv)(B) for personnel hoisting by cranes and derricks, and OSHA Directive CPL 2-1.36 — Interim Inspection Procedures During Communication Tower Construction Activities. Only a Crosby or McKissick Hook with a PL latch attached and secured with a bolt, nut and cotter pin (or toggle pin) or a PL-N latch attached and secured with toggle pin; or a Crosby hook with an S-4320 latch attached and secured with cotter pin or bolt, nut and pin; or a Crosby SHUR-LOC® Hook in the locked position may be used for any personnel hoisting. A hook with a Crosby SS-4055 latch attached shall NOT be used for personnel lifting.
- Instruct workers to be alert and to wear proper safety gear in areas where loads are moved or supported with tackle block systems.
- Use only genuine Crosby parts as replacement.
- Read, understand, and follow these instructions to select, use and maintain tackle block systems.
- Do not use a block or ball that does not have a legible capacity tag.

### Important:

For maximum safety and efficiency, tackle block and sheave systems must be properly designed, used, and maintained. You must understand the use of tackle block components and sheaves in the system. These instructions provide this knowledge. Read them carefully and completely.

Some parts of these instructions must use technical words and detailed explanations. NOTE: If you do not understand all words, diagrams, and definitions – **DO NOT TRY TO DESIGN OR USE A TACKLE BLOCK OR SHEAVE SYSTEM!** For further assistance, call:

**In U.S.A.** – Crosby Engineered Products Group at 800-777-1555.

**In CANADA** – Crosby Canada, Ltd. (905) 451-9261.

**In EUROPE** – N.V. Crosby Europe 32-15-757125.

As you read instructions, pay particular attention to safety information in bold print.

**KEEP INSTRUCTIONS FOR FUTURE USE – DO NOT THROW AWAY!**

## General Cautions or Warnings

Ratings shown in Crosby Group literature are applicable only to new or “in as new” products.

Working Load Limit ratings indicate the greatest force or load a product can carry under usual environmental conditions. Shock loading and extraordinary conditions must be taken into account when selecting products for use in tackle block systems. Working Load Limit ratings are based on all sheaves of tackle block system being utilized. If all sheaves are not utilized, balance must be maintained, and the Working Load Limit must be reduced proportionally to prevent overloading sheave components. Changes from full sheave reeving arrangement should be only at the recommendation of a qualified person, and incorporate good rigging practices.

In general, the products displayed in Crosby Group literature are used as parts of a system being employed to accomplish a task. Therefore, we can only recommend within the Working Load Limits, or other stated limitations, the use of products for this purpose.

The Working Load Limit or Design (Safety) Factor of each Crosby product may be affected by wear, misuse, overloading, corrosion, deformation, intentional alteration, and other use conditions. Regular inspection must be conducted to determine whether use can be continued at the catalog assigned WLL, a reduced WLL, a reduced Design (Safety) Factor, or withdrawn from service.

Crosby Group products generally are intended for tension or pull. Side loading must be avoided, as it exerts additional force or loading which the product is not designed to accommodate.

Always make sure the hook supports the load. The latch must never support the load.

Welding of load supporting parts or products can be hazardous. Knowledge of materials, heat treatment, and welding procedures are necessary for proper welding. Crosby Group should be consulted for information.

Crane component parts, i.e., the boom, block, overhaul ball, swivel, and Wirelines are metallic and will conduct electricity. Read and understand OSHA standard covering crane and derrick operations (29 CFR 1926.1501 SUBPART N) before operating proximate to power lines.

## Definitions

**STATIC LOAD** – The load resulting from a constantly applied force or load.

**WORKING LOAD LIMIT** – The maximum mass or force which the product is authorized to support in general service when the pull is applied in-line, unless noted otherwise, with respect to the center line of the product. This term is used interchangeably with the following terms.

1. WLL
2. Rated Load Value
3. SWL
4. Safe Working Load
5. Resultant Safe Working Load

**WORKING LOAD** – The maximum mass or force which the product is authorized to support in a particular service.

**PROOF LOAD** – The average force applied in the performance of a proof test; the average force to which a product may be subjected before deformation occurs.

**PROOF TEST** – A test applied to a product solely to determine non-conforming material or manufacturing defects.

**ULTIMATE LOAD** – The average load or force at which the product fails, or no longer supports the load.





**SHOCK LOAD** – A force that results from the rapid application of a force (such as impacting and/or jerking) or rapid movement of a static load. A shock load significantly adds to the static load.

**DESIGN (SAFETY) FACTOR** – An industry term denoting a product's theoretical reserve capability, usually computed by dividing the catalog Ultimate Load by the Working Load Limit. Generally expressed for blocks as a ratio of 4 to 1.

**TACKLE BLOCK** – An assembly consisting of a sheave(s), side plates, and generally an end fitting (hook, shackle, etc.) that is used for lifting, lowering, or applying tension.

**SHEAVE / SHEAVE BEARING ASSEMBLY** – Purchased by O.E.M. or end user to be used in their block or lifting system design.

## Fitting Maintenance

Fittings, including hooks, overhaul balls, shackles, links, etc., may become worn and disfigured with use, corrosion, and abuse resulting in nicks, gouges, worn threads and bearings, sharp corners which may produce additional stress conditions and reduce system load capacity.

Grinding is the recommended procedure to restore smooth surfaces. The maximum allowance for reduction of a product's original dimension due to wear or repair before removal from service is:

1. Any single direction - No more than 10% of original dimension;
2. Two directions - No more than 5% of each dimension.

For detailed instructions on specific products, see the application and warning information for that product. Any greater reduction may necessitate a reduced Working Load Limit.

Any crack or deformation in a fitting is sufficient cause to withdraw the product from service.

## Selection Guide

Some of the blocks shown in Crosby Group literature are named for their intended use and selection is routine. A few examples include the "Double Rig Trawl Block" used in the fishing industry, the "Well Loggers Block" used in the oil drilling industry, and the "Cargo Hoisting Block" used in the freighter boat industry and "Derrick and Tower Block" used for hoisting personnel. Others are more generally classified and have a variety of uses. They include snatch blocks, regular wood blocks, standard steel blocks, etc. For example, snatch blocks allow the line to be attached by opening up the block instead of threading the line through the block. This feature eliminates the use of rope guards and allows various line entrance and exit angles to change direction of the load. These angles determine the load on the block and/or the block fitting. (See "Loads on Blocks.") Snatch blocks are intended for infrequent and intermittent use with slow line speeds.

A tackle block sheave assembly is one element of a system used to lift, change direction or drag a load. There are other elements in the system including the prime mover (hoist, winch, hand), supporting structure, power available, etc. All of these elements can influence the type of tackle block or sheave required. When selecting a block or sheave for the system in your specific application, you should consider the other elements as well as the features of the blocks and sheaves shown in Crosby Group literature.

To select a tackle block or sheave to fit your requirements, consider the following points:

1. Are there regulations which could affect your choice of blocks or sheaves, such as federal or state, OSHA, elevator safety, mine safety, maritime, insurance, etc.?
2. What is the weight of the load, including any dynamics of impacts that add to load value? You must know this to determine the minimum required Working Load Limit value of the block or load on sheave.
3. How many parts of line are required? This can be determined given the load to be lifted and the line pull you have available. As an alternative, you could calculate the line pull required with a given number of parts of line and a given load weight.  
(See "How to Figure Line Parts.")
4. What is the size of line to be used? Multiply the available line pull by the desired safety factor for Wireline to determine the minimum catalog Wireline breaking strength; consult a Wireline catalog for the corresponding grade and diameter of Wireline to match. You should also consider fatigue factors that affect Wireline life. (See "Sheave Size & Wireline Strength.")
5. What is the speed of the line? This will help you determine the type of sheave bearing necessary. There are several choices of bearings suitable for different applications, including:
  - A. **Common (Plain) Bore** for very slow line speeds and very infrequent use (high bearing friction).
  - B. **Self Lubricating Bronze Bushings** for slow line speeds and infrequent use (moderate bearing friction).
  - C. **Bronze Bushing** with pressure lubrication for slow line speeds and more frequent use at greater loads (moderate bearing friction).
  - D. **Anti-friction Bearings** for faster line speeds and more frequent use at greater loads (minimum bearing friction).
6. What type of fitting is required for your application? The selection may depend on whether the block will be traveling or stationary. Your choices include single or multiple hooks with or without throat latches and shackles, which are the most secured load attachment. You should also decide whether the fitting should be fixed, swivel or swivel with lock. If it is a swivel fitting, then selection of a thrust bearing may be necessary. There are plain fittings with no bearings for positioning at no load, bronze bushed fittings for infrequent and moderate load swiveling, and anti-friction bearing equipped fittings for frequent load swiveling.
7. How will the block be reeved and does it require a dead end becket? (See "The Reeving of Tackle Blocks.")
8. If the block is to be a traveling block, what weight is required to overhaul the line? (See "How to Determine Overhaul Weights.")
9. What is the fleet angle of the Wireline? Line entrance and exit angles should be no more than 1-1/2 degrees.
10. How will the block or sheave be maintained? Do conditions in your application require special maintenance considerations? (See "Tackle Block and Sheave Maintenance," and "Fitting Maintenance.")
11. Reference current edition of "Wireline Users Manual" for additional sheave design and maintenance information.



## Tackle Block and Sheave Maintenance

Tackle Blocks and Sheaves must be regularly inspected, lubricated, and maintained for peak efficiency and extended usefulness. Their proper use and maintenance is equal in importance to other mechanical equipment. The frequency of inspection and lubrication is dependent upon frequency and periods of use, environmental conditions, and the user's good judgment.

**Inspection:** As a minimum, the following points should be considered:

1. Wear on pins or axles, rope grooves, side plates, bushing or bearings, cases, trunnions, hook shanks, and fittings (See Fitting Maintenance). Excessive wear may be a cause to replace parts or remove block or sheave from service.
2. Deformation in side plates, pins and axles, fitting attachment points, trunnions, etc. Deformation can be caused by abusive service and / or overload and may be a cause to remove block or sheave from service.
3. Misalignment or wobble in sheaves.
4. Security of nuts, bolts, and other locking methods, especially after reassembly following a tear down inspection. Original securing method should be used; e.g., staking, set screw, cotter pin, cap screw.
5. Pins retained by snap rings should be checked for missing or loose rings.
6. Sheave pin nuts should be checked for proper positioning. Pins for tapered roller bearings should be tightened to remove all end play during sheave rotation. Pins for bronze bushings and straight roller bearings should have a running clearance of .031 inch per sheave of end play and should be adjusted accordingly.
7. Hook or shackle to swivel case clearance is set at .031 to .062 at the factory. Increased clearance can result from component wear. Clearance exceeding .12 to .18 should necessitate disassembly and further inspection.
8. Deformation or corrosion of hook and nut threads. Your block's hook may be fitted with the Crosby/McKissick Patented Split Nut. Refer to the Split Nut section for proper removal, inspection and installation procedures.
9. Loss of material due to corrosion or wear on external area of welded hook and nut may indicate thread corrosion or damage. If these conditions exist, remove from service or perform load test.
10. Surface condition and deformation of hook (See Fitting Maintenance and ANSI B30.10.)
11. Welded side plates for weld corrosion or weld cracking.
12. Hook latch for deformation, proper fit and operation.
13. Remove from service any bushings with cracks on inside diameter or bushing end. Bushings that are cracked and/or extended beyond sheave hub are indications of bushing overload.

**LUBRICATION:** The frequency of lubrication depends upon frequency and period of product use as well as environmental conditions, which are contingent upon the user's good judgment. Assuming normal product use, the following schedule is suggested when using lithium-base grease of a medium consistency.

### SHEAVE BEARINGS

**Tapered Roller Bearings** – Every 40 hours of continuous operation or every 30 days of intermittent operation.

**Roller Bearings** – Every 24 hours of continuous operation or every 14 days of intermittent operation.

**Bronze Bushings** – (Not Self Lubricated) – Every 8 hours of continuous operation or every 14 days of intermittent operation.

**Self Lubricating Bronze Bushing** – are for slow line speeds and infrequent use (moderate bearing friction). Frequent inspection is required to determine the condition of bushing.

### HOOK BEARINGS

**Anti Friction** – Every 14 days for frequent swiveling; every 45 days for infrequent swiveling.

**Bronze Thrust Bushing or No Bearing** Every 16 hours for frequent swiveling; every 21 days for infrequent swiveling.

Tackle Block Maintenance also depends upon proper block selection (see "Loads on Blocks"), proper reeving (see "The Reeving of Tackle Blocks"), consideration of shock loads, side loading, and other adverse conditions.

## Sheave Bearing Application Information

Sheaves in a system of blocks rotate at different rates of speed, and have different loads. When raising and lowering, the line tension is not equal throughout the system. Refer to Page 387 "How to Figure Line Parts" for assistance in determining lead line loads used for bushing or bearing selection.

### BRONZE BUSHINGS

Bronze Bushings are used primarily for sheave applications using slow line speed, moderate load, and moderate use. The performance capability of a bearing is related to the bearing pressure and the bearing surface velocity by a relationship known as true PV (Maximum Pressure - Velocity Factor).

The material properties of the Bronze Bushings furnished as standard in Crosby catalog sheaves are:

(BP) Maximum Bearing Pressure :4500 PSI

(BV) Maximum Velocity at Bearing :1200 FPM

(PV) Maximum Pressure Velocity Factor: 55000

(It should be noted that due to material property relations, the maximum BP times the maximum BV is NOT equal to the maximum PV.) Formula for Calculating Bearing Pressure:

#### Formula for Calculating Bearing Pressure:

$$BP = \frac{\text{Line Pull} \times \text{Angle Factor}}{\text{Shaft Size} \times \text{Hub Width}}$$

Note: Angle Factor Multipliers listed on page 384.

#### Formula for Calculating Bearing Velocity:

$$BV = \frac{PV}{BP}$$

#### Formula for Calculating Line Speed:

$$\text{Line Speed} = \frac{BV (\text{Tread Diameter} + \text{Rope Diameter})}{\text{Shaft Diameter}}$$

Calculations can be made to find the maximum allowable line speed for a given total sheave load. If the required line speed is greater than the maximum allowable line speed calculated, then increase the shaft size and/or the hub width and recalculate. Continue the process until the maximum allowable line speed is equal to or exceeds the required line speed.

#### Example

Using a 14 in. sheave; (Stock # 917191; refer to Wireline sheave section of this catalog for dimensions) with a 4,600 lbs. line pull and an 80° angle between lines determine maximum allowable line speed.

$$BP = \frac{4,600 \text{ lbs.} \times 1.53}{1.50 \times 1.62}$$

(Line pull) (Angle Factor)  
(Shaft Size) (Hub Width)

$$BV = \frac{55,000 \text{ (PV Factor)}}{2,896 \text{ (BP)}} = 19 \text{ FPM Allowable}$$



**Line Speed =**  
 $[19 \times (11.75 + .75)] \div 1.50 = 158.3 \text{ FPM ALLOWABLE}$   
 (BV) (Tread Dia. + Rope Size)  $\div$  (Shaft Dia.)

If the application required a line speed equal to 200 FPM, then another calculation would be necessary. Trying another 14 in. sheave (stock # 4104828) under the same loading conditions, the results are as follows:

**BP = (4,600 lbs. x 1.53)  $\div$  (2.75 x 2.31) = 1,108 PSI**

**BV = 55,000  $\div$  1,108 = 50 FPM**

**Line Speed =**  
 $[50 \times (11.75 + .75)] \div 2.75 = 227.3 \text{ FPM ALLOWABLE}$

**COMMON (PLAIN) BORE –**  
 Very slow line speed, very infrequent use, low load.

**ROLLER BEARING –**  
 Faster line speeds, more frequent use, greater load. Refer to manufacturer's rating. Reference appropriate bearing manufacturer's catalog for proper bearing selection procedure.

### Loads on Blocks

The Working Load Limit (WLL) for Crosby Group blocks indicates the maximum load that should be exerted on the block and its connecting fitting.

This total load value may be different from the weight being lifted or pulled by a hoisting or hauling system. It is necessary to determine the total load being imposed on each block in the system to properly determine the rated capacity block to be used.

A single sheave block used to change load line direction can be subjected to total loads greatly different from the weight being lifted or pulled. The total load value varies with the angle between the incoming and departing lines to the block.

The following chart indicates the factor to be multiplied by the line pull to obtain the total load on the block.

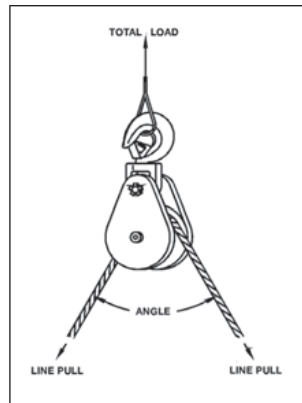

**Angle Factor Multipliers**

Angle	Factor	Angle	Factor
0°	2.00	100°	1.29
10°	1.99	110°	1.15
20°	1.97	120°	1.00
30°	1.93	130°	.84
40°	1.87	135°	.76
45°	1.84	140°	.68
50°	1.81	150°	.52
60°	1.73	160°	.35
70°	1.64	170°	.17
80°	1.53	180°	.00
90°	1.41	—	—

### Example A

(Calculations for determining total load value on single line system.)

A gin pole truck lifting 1,000 kg

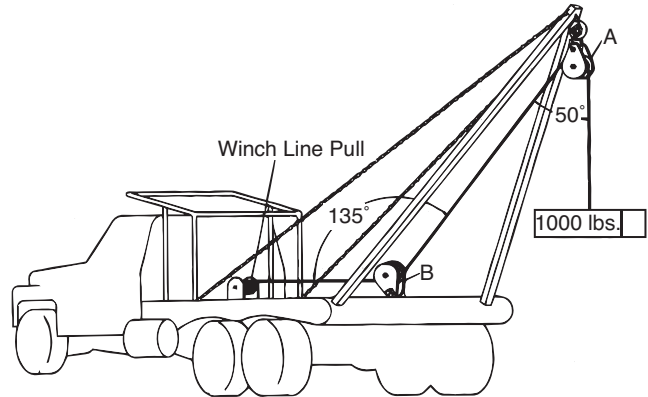

There is no mechanical advantage to a single part load line system, so winch line pull is equal to 1,000 kg or the weight being lifted.

To determine total load on snatch block A:  
**A = 1,000 kg x 1.81 = 1,810 kg**  
 (line pull) (factor 50° angle)

To determine total load on toggle block B:  
**B = 1,000 kg x .76 = 760 kg**  
 (line pull) (factor 135° angle)





### Example B

(Calculation for determining total load value for mechanical advantage system.)

Hoisting system lifting 1,000 kg using a traveling block. The mechanical advantage of traveling block C is 2.00 because two (2) parts of load line support the 1,000 kg weight. (Note that this example is simplified for determination of resultant load on blocks. Lead line pull will be greater than shown due to efficiency losses.) (To determine single line pull for various bearing efficiency see "How to Figure Line Parts".)

To Determine Line Pull:

$$\text{Line Pull} = 1,000 \text{ kg} \div 2.00 = 500 \text{ kg}$$

To determine total load on traveling block C:

$$C = 500 \text{ kg} \times 2.0 = 1,000 \text{ kg.}$$

(line pull)(Factor 0° angle)

To determine total load on stationary block D:

$$D = 500 \text{ kg} \times 1.87 + 500 \text{ kg} = 1,435 \text{ kg}$$

(line pull) (dead-end load)  
(Factor 40° angle)

To determine total load on block E:

$$E = 500 \text{ kg} \times .84 = 420 \text{ kg}$$

(line pull) (Factor 130° angle)

To determine total load on block F:

$$F = 500 \text{ kg} \times 1.41 = 705 \text{ kg}$$

(line pull) (Factor 90° angle)

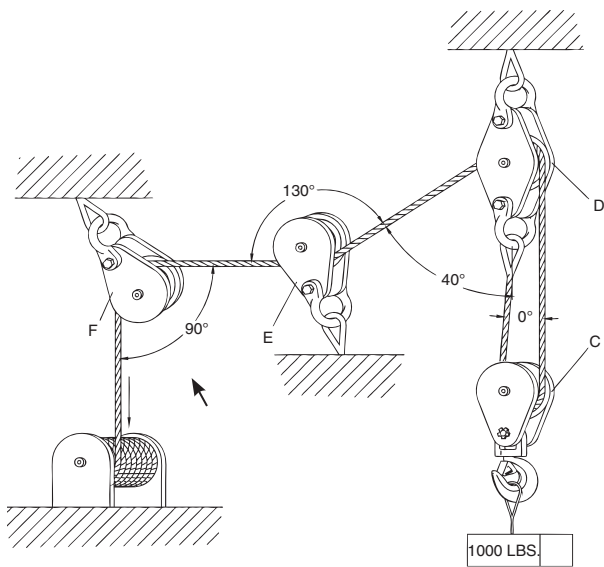

## The Reeving of Tackle Blocks

In reeving of tackle blocks, there are many methods. The method discussed below is referred to as "Right Angle" reeving. Please consult your rigging manual for other methods of reeving.

### RIGHT ANGLE REEVING

In reeving a pair of tackle blocks, one of which has more than two sheaves, the hoisting rope should lead from one of the center sheaves of the upper block to prevent toppling and avoid injury to the rope. The two blocks should be placed so that the sheaves in the upper block are at right angles to those in the lower one, as shown in the following illustrations.

Start reeving with the becket or dead end of the rope. **Use a shackle block as the upper one of a pair and a hook block as the lower one as seen below.** Sheaves in a set of blocks revolve at different rates of speed. Those nearest the lead line revolve at the highest rate of speed and wear out more rapidly. All sheaves should be kept well lubricated when in operation to reduce friction and wear.

Reeving Diagram

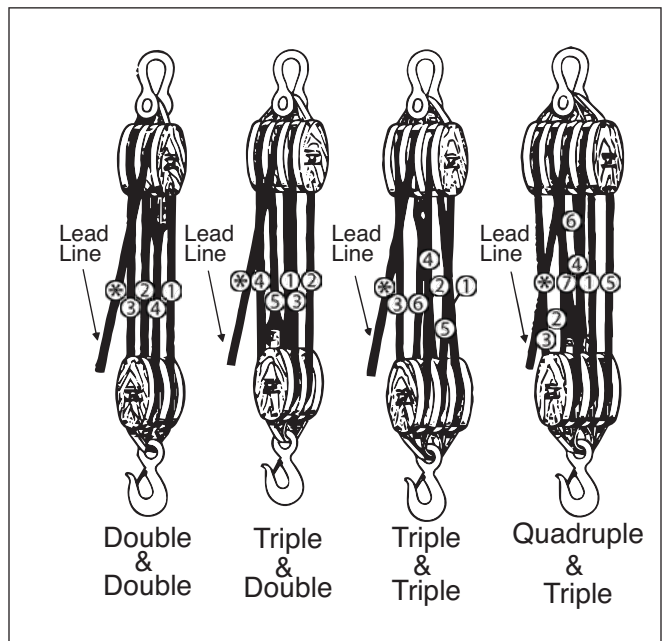

### CAUTION

- Exercise care when block is standing in vertical position, as the potential for tipping exists. Potential causes of tipping are unstable work area, boom movement and the reeving process.
- If work area is unstable, lay block flat on side plate.



## Sheave Size & Wireline Strength

### Strength Efficiency

Bending Wireline reduces its strength. To account for the effect of bend radius on Wireline strength when selecting a sheave, use the table below:

Ratio A	Strength Efficiency Compared to Catalog Strength in %
40	95
30	93
20	91
15	89
10	86
8	83
6	79
4	75
2	65
1	50

$$\text{Ratio A} = \frac{\text{Sheave Diameter}}{\text{Rope Diameter}}$$

#### Example

To determine the strength efficiency of 1/2" diameter Wireline using a 10" diameter sheave:

$$\text{Ratio A} = \frac{10'' \text{ (sheave diameter)}}{1/2'' \text{ (Wireline diameter)}} = 20$$

Refer to ratio A of 20 in the table then check the column under the heading "Strength Efficiency Compared to Catalog Strength in %"...91% strength efficiency as compared to the catalog strength of Wireline.

### Fatigue Life

Repeated bending and straightening of Wireline causes a cyclic change of stress called "fatiguing." Bend radius affects Wireline fatigue life. A comparison of the relative effect of sheave diameter on Wireline fatigue life can be determined as shown below:

Ratio B	Relative Fatigue Bending Life
30	10.0
25	6.6
20	3.8
18	2.9
16	2.1
14	1.5
12	1.1

$$\text{Ratio B} = \frac{\text{Sheave Diameter}}{\text{Rope Diameter}}$$

$$\text{Relative Fatigue Bending Life} = \frac{\text{Relative Fatigue Bending Life Sheave \#1}}{\text{Relative Fatigue Bending Life (Sheave \#2)}}$$

#### Example

To determine the extension of fatigue life for a 20mm Wireline using a 600mm diameter sheave versus a 320mm diameter sheave:

$$\text{Ratio B} = \frac{600\text{mm (sheave diameter)}}{20\text{mm (Wireline diameter)}} = 30$$

$$\text{Ratio B} = \frac{320\text{mm (sheave diameter)}}{20\text{mm (Wireline diameter)}} = 16$$

The relative fatigue bending life for a ratio B of 16 is 2.1 (see above Table) and ratio B of 30 is 10.

$$\text{Relative Fatigue Bending Life} = \frac{10}{2.1} = 4.7$$

Therefore, we expect extension of fatigue life using a 600mm diameter sheave to be 4.7 times greater than that of a 320mm diameter sheave.



## How to Determine Overhauling Weights

To determine the weight of the block or overhaul ball that is required to free fall the block, the following information is needed: size of Wireline, number of line parts, type of sheave bearing, length of crane boom, and drum friction (use 25kg unless other information is available).

Wireline Size (in.)	Factor A – Wireline Weight lbs. per ft., 6 x 19 IWRC
3/8	.26
7/16	.35
1/2	.46
9/16	.59
5/8	.72
3/4	1.04
7/8	1.42
1	1.85
1-1/8	2.34
1-1/4	2.89

Number of Line Parts	Factor B – Overhaul Factors	
	Roller Bearing Sheaves	Bronze Bushed Sheaves
1	1.03	1.05
2	2.07	2.15
3	3.15	3.28
4	4.25	4.48
5	5.38	5.72
6	6.54	7.03
7	7.73	8.39
8	8.94	9.80
9	10.20	11.30
10	11.50	12.80

The Formula is:

$$\text{Required Block Weight} = [(\text{Boom Length} \times \text{Factor A}) + \text{Drum Friction}] \times \text{Factor B}$$

### Example:

To determine the required block or overhaul weight using 5 parts of 7/8" diameter Wireline, a 50 ft. boom and roller bearing sheaves:

$$\text{Required Block Weight} = [(50 \text{ ft.} \times 1.42) + 50 \text{ lbs.}] \times 5.38 = 651 \text{ lbs.}$$

(Boom Length)
(Drum Friction)
(Factor A)
(Factor B)

## How to Figure Line Parts

Sheaves in a system of blocks rotate at different rates of speed, and have different loads. When raising and lowering, the line tension is not equal throughout the system. To help figure the number of parts of line to be used for a given load, or the line pull required for a given load, (for example, use Reeving Diagram on page 385. Only numbered lines shall be used in the calculation). The following ratio table is provided with examples of how to use it. The ratios are applicable for blocks as shown on page 385 and also independent sheave systems that line is reeved through.

Ratio A Bronze Bushed Sheaves	Ratio B Anti-Friction Bearing Sheaves	Number of Line Parts
.96	.98	1
1.87	1.94	2
2.75	2.88	3
3.59	3.81	4
4.39	4.71	5
5.16	5.60	6
5.90	6.47	7
6.60	7.32	8
7.27	8.16	9
7.91	8.98	10
8.52	9.79	11
9.11	10.60	12
9.68	11.40	13
10.20	12.10	14
10.70	12.90	15
11.20	13.60	16
11.70	14.30	17
12.20	15.00	18
12.60	15.70	19
13.00	16.40	20

$$\text{Ratio A or B} = \frac{\text{Total Load to be Lifted}}{\text{Single Line Pull (lbs.)}}$$

After calculating Ratio A or B, consult table to determine number of parts of line.

### Examples:

To find the number of parts of line needed when weight of load and single line pull are known, and using Bronze Bushed Sheaves.

$$\text{Ratio A} = \frac{72,180 \text{ kg (load to be lifted)}}{8000 \text{ kg (single line pull)}} = 9.02 \text{ (Ratio A)}$$

In table above refer to ratio 9.02 or next higher number, then check column under heading "Number of Line Parts" = 12 parts of line to be used for this load.

To find the single line pull needed when weight of load and number of parts of line are known, and using Anti-Friction Bearing Sheaves.

$$\text{Single Line Pull} = \frac{68,000 \text{ kg (load to be lifted)}}{7.32 \text{ (Ratio B of 8 part line)}} = 9,290 \text{ kg}$$

9,290 kg single line pull required to lift this load on 8 parts of line.



To find the lift capacity when the parts of line and single line pull are known, and using anti-friction bearing sheaves.

**10,000 kg** (Single line pull)  
**x 4.71** (Ratio B of 5 parts of line)  
**= 47.100 kg** (Lift Capacity)

10,000 kg single line pull with 5 parts of line will accommodate 47.100 kg lift capacity.

### Repairs

For repair of blocks, contact the following numbers for return material authorization.

**IN U.S.A.** – Crosby Engineered Products Group at (800) 777-1555

**IN CANADA** – Crosby Canada at (905) 451-9261

**IN EUROPE** – N.V. Crosby Europe at (+32) (0)15 75 71 25

Your block, after receipt by Crosby, will be inspected and a free estimate of repair charges will be provided. Authorization for repairs from block owners must be given to Crosby before repairs are made. Transportation charges, both to and from factory, are to be paid by the block owner.

### Additional Information

For information concerning parts, special application, or situations requiring other features, contact:

#### U.S.A.

The Crosby Group LLC  
P.O. Box 3128  
Tulsa, OK 74101-3128  
(918) 834-4611  
FAX (918) 832-0940  
www.thecrosbygroup.com  
crosbygroup@thecrosbygroup.com

#### CANADA

Crosby Canada  
145 Heart Lake Road  
Brampton, Ontario, Canada L6W 3K3  
(905) 451-9261  
FAX (877)260-5106  
www.thecrosbygroup.com  
sales@crosby.ca

#### EUROPE

Belgium  
Industriepark Zone B n°26  
2220 Heist-op-den-Berg.  
P: (+32) (0)15 75 71 25  
F: (+32) (0)15 75 37 64  
www.thecrosbygroup.com  
sales@crosbyeurope.com

### How to Find Your Nearest Crosby Distributor

To locate your nearest Crosby Distributor, call:

**IN U.S.A.** – Crosby Engineered Products Group at (800) 777-1500

**IN CANADA** – Crosby Canada at (905) 451-9261

**IN EUROPE** – N.V. Crosby Europe at (+32) (0)15 75 71 25

## CROSBY® TUBING GRAB

### WARNINGS & APPLICATION INSTRUCTIONS



TGRB - Tubing Grab

#### WARNING

- Loads may disengage from Tubing Grab if proper procedures are not followed.
- A falling load may cause serious injury or death.
- Never exceed the Working Load Limit (WLL).
- Inspect the Tubing Grab for damage and proper operation before each use.
- Do not use with worn or damaged tubing.
- Do not allow the Tubing Grab or the load to come into contact with any other object during the lift.
- Do not allow the Tubing Grab or load to bounce or allow the hoist line to become slack during the lift.
- Do not use more than one Tubing Grab to lift a section of tubing.
- Do not attempt to detach the Tubing Grab from the tubing when loaded.
- Read and understand these instructions before using the Tubing Grab.

#### Important Safety Information Read and follow

- Tubing grabs are designed to work with a specific tubing diameter. Do not attempt to lift any other type of object, or tubing of a different diameter.
- The weight of the load shall be known, calculated, estimated, or measured prior to lifting.
- Shock loading should be avoided.
- See ASME B30.20, BELOW-THE-HOOK LIFTING DEVICES; ASME BTH-1, DESIGN OF BELOW-THE-HOOK LIFTING DEVICES; NEN-EN 13155: "CRANES-SAFETY-NON-FIXED LOAD LIFTING ATTACHMENTS" for additional information.

#### Operating Practices

- To install on tubing, pull the trigger fully, and press the jaws over the tubing. Release the trigger and verify the trigger is fully in the locked or forward position prior to applying a load. The operator's hands must be free of the grab prior to applying the load.
- The grab must be installed adjacent to the flared end of the tubing or the coupler (see Figures 1 & 2). Do not attempt to attach the grab directly to the larger diameter flared end or the coupler (see Figure 3).

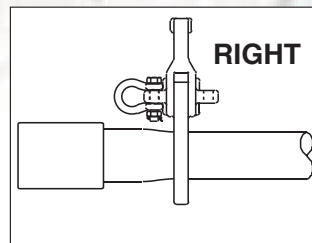

Figure 1

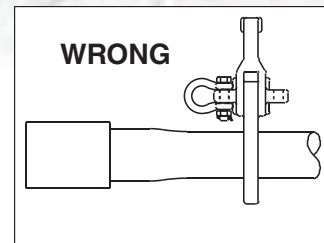

Figure 2

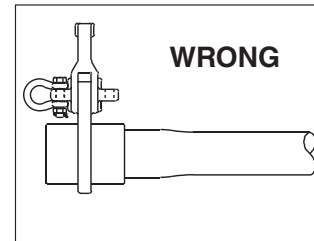

Figure 3

- The hoist line may only apply the load in a 90° range (see Figure 4). Do not apply a load in any other direction or allow the hoisting line to come into contact with the grab (see Figures 5 & 6). The hoist line must pull towards the coupler end.

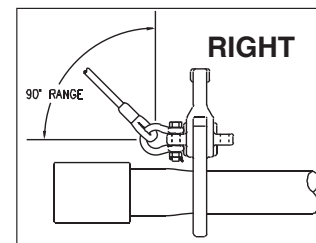

Figure 4

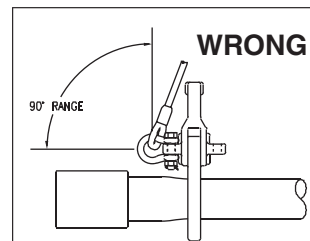

Figure 5

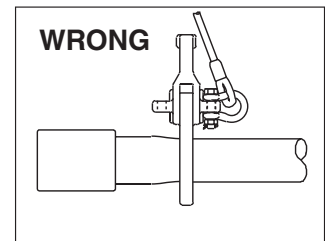

Figure 6

- After the grab has been attached to the tubing, apply force slowly. Watch the load and be prepared to stop lifting if the load moves in an uncontrolled manner.
- The grab may slide on the tubing when the load is applied; keep hands free of the tubing.
- Personnel shall stand clear of the suspended load.
- Personnel shall not be lifted by the grab or by any object connected to the grab.
- During lifting, with or without a load, personnel should be alert for possible snagging.
- The grab should not be dragged on the ground or over abrasive surface.
- Lubrication may be used to keep components moving freely and to prevent corrosion.
- The grab must be kept free of dirt and debris to ensure free movement of components.



- The tubing grab shall be removed from service if any of the following are true:
  - The trigger does not slide freely through entire operating range.
  - The jaw does not rotate freely through entire operating range.
  - The trigger spring or the pivot spring is missing, damaged, or not functioning properly.
  - The pivot pin retaining ring is missing or damaged.
  - Wear, corrosion, or loss of material exceeding 10% of any original dimension.
  - Cracks, breaks, stretching, or bending.
  - Welding, modification, or alteration of any component.
  - Missing or illegible product markings.
- Nicks, gouges, or other wear resulting in sharp corners should be repaired by grinding to restore smooth surfaces. The maximum allowance for reduction of any original dimension is 10%.
- The springs may lose strength or break through normal use and may need to be periodically replaced. Use only genuine Crosby replacement parts.
- The grab or its components may not be subjected to any plating or galvanizing process. The grab is originally supplied with a zinc plated finish and may be painted for additional corrosion control or for identification purposes. Internal sliding or mating surfaces shall not be painted.

### **Environmental Effects**

- The grab is designed for normal operating temperatures of -40°F(-40°C) to 200°F(93°C).
- Do not expose the grab to chemically active environments such as acids or corrosive liquids or fumes. The detrimental effects of chemical exposure can be both visible loss of material and undetectable material degradation resulting in significant loss of strength.





- Ultimate Test Capability – 726 metric tons
- Proof Test Capability (Shackles) – 2000 metric tons
- Full reeving block testing by to 907 metric tons
- Complete laboratory facilities for all phases of metallurgical testing and inspection.
- Certifications available for all national standards, American Bureau of Shipping, Lloyd's Register of Shipping, Det Norske Veritas, etc.





# “The Standard” in Cell Tower Securment

When it comes to the securment of cell towers, Crosby® sets the industry standard with superior products, in-depth training, and time-tested expertise. For years, we have fulfilled the unique needs of each and every cell tower company that we’ve partnered with.



**Turnbuckle  
Fittings**



**Wire Rope  
End Fittings**







# WESTERN & MARINE BLOCKS

With Product Warnings and Application Information



# Correct Ordering of Western Blocks

## IMPORTANT

### Helpful Information and Recommended Procedure for the Correct Ordering of Western Blocks

In selecting blocks, the governing consideration should be the load to be handled, rather than diameter or strength of the rope they will support. In multiple sheave blocks, the load is distributed among several parts of the rope, whereas the hooks or shackles on the blocks have to support the entire load. It is not practical to make double blocks twice as strong and triple blocks three times as strong as single blocks, since they would be too heavy and needlessly expensive for general use.

#### WHEN ORDERING, ALWAYS SPECIFY:

- Letter of Fitting,
- Block Series,
- Letter of Bearing, and
- Size.

#### EXAMPLE:

For ordering a 4" Single Wood Block with Loose Side Latch Hook, Common Iron Bearing, simply specify as shown here.

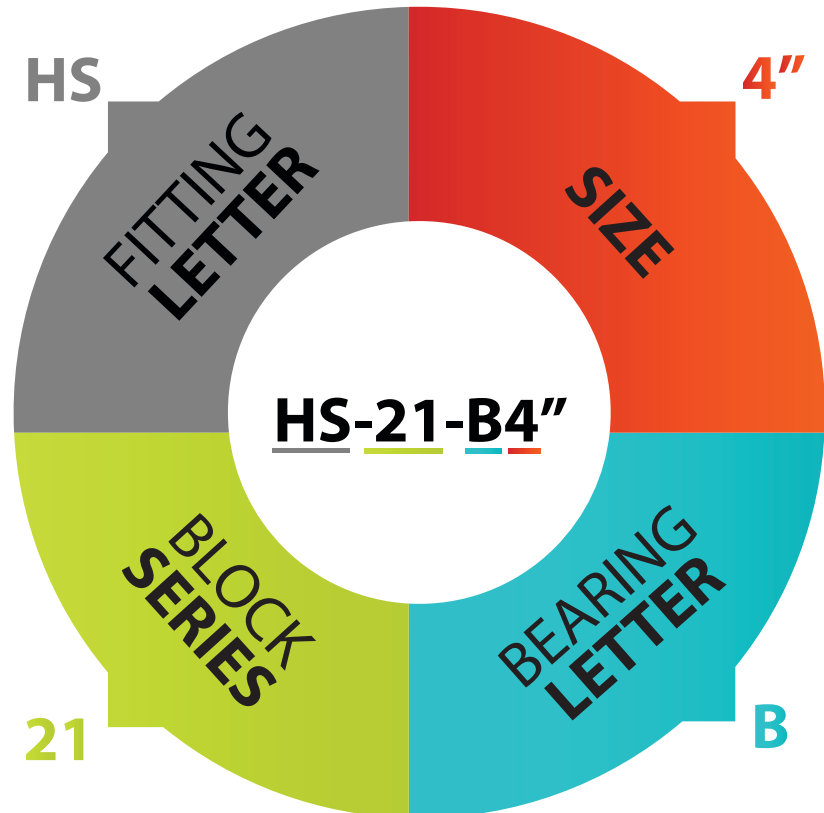

If blocks are not shown with type of fitting you require, simply choose letter corresponding to your fitting need and insert where "HS" appears in the above example.

Unless otherwise specified, all material will be furnished in galvanized finish.

All certified single blocks are proof tested to twice the Resultant Safe Working Load and marked with a working load equal to one half the resultant load. Double blocks are tested to twice the Resultant Safe Working Load and marked with a working load equal to the resultant load. All blocks except snatch blocks are furnished with becket. Blocks without becket on special order only.

When blocks are used for heavy loads and fast hoisting, we strongly recommend roller or bronze bearings in the sheaves. For wire rope blocks, cast steel sheaves are recommended.

#### SPECIAL CUSTOM-MADE BLOCKS. . .

We manufacture a large number of Special Blocks to meet particular requirements. Specify type block, diameter of sheave, diameter of manila or wire rope to be used, and weight of load.



# The Western Block Line

**If today's technology was available over a century ago . . .  
 . . . this is the way Western Blocks would have been produced.**

- Bolt style center pin with lock washer and staked nut
- No straps
- Laser burned side plates
- Every block permanently stamped with the following:
  - Working Load Limit
  - Block and Rope Size

## 385 WOOD SHELL MANILA ROPE SNATCH BLOCK

- New stock numbers
- New higher working load limits
- Painted or galvanized steel
- Laser cut side plate opens for insertion of rope
  - Incorporates exclusive bolt retaining spring to assure no lost bolts, plus utilizes secondary retaining pin
- Bronze bushed sheaves with larger bearing diameter for extended block life
- Lubricated center pin
- 10" and 12" sizes utilize steel sheaves



## 301-302-303 STEEL SHELL BLOCKS FOR MANILA ROPE

- Same stock numbers
- Same working load limits
- Same fittings available
- Laser cut side plates
- Galvanized steel
- Grade 5 bolts secured with lock washers and staked nuts
- Bronze bushed sheaves with larger bearing diameter for extended block life
- New style hanger for fitting attachment



## 261-262-263 STANDARD STEEL SHELL BLOCKS FOR MANILA ROPE

- Same stock numbers
- Same working load limits
- Same fittings available
- Laser cut side plates
- Painted steel
- Grade 5 bolts secured with lock washers and staked nuts
- Bronze bushed sheaves with larger bearing diameter for extended block life



## 390 STEEL SHELL MANILA ROPE SNATCH BLOCK

- New stock numbers
- New higher working load limits
- Painted or galvanized steel
- Laser cut side plate opens for insertion of rope.
  - Incorporates exclusive bolt retaining spring to assure no lost bolts, plus utilizes secondary retaining pin
- Bronze bushed sheaves with larger bearing diameter for extended block life
- Lubricated center pin
- 10" and 12" sizes utilize steel sheaves



## 411-412-413 STEEL SHELL BLOCK FOR SYNTHETIC ROPE

- Same stock numbers
- Same working load limits
- Same fittings available
- Laser cut side plates
- Painted steel
- Grade 5 bolts secured with lock washers and staked nuts
- Bronze bushed sheaves with larger bearing diameter for extended block life



## 261-262 5" STEEL SHELL BLOCKS FOR WIRE ROPE

- Same stock numbers
- Same working load limits
- Same fittings available
- Laser cut side plates
- Painted steel
- Grade 5 bolts secured with lock washers and staked nuts
- Bronze bushed sheaves with larger bearing diameter for extended block life



## 310 - 135 PAINTER'S SUPPLY BLOCK FOR MANILA ROPE

- Same stock numbers
- Same working load limits
- Same fittings available
- Laser cut side plates
- Galvanized steel
- Grade 5 bolts secured with lock washers & staked nuts
- Replaceable wood bumpers
- Bronze bushed sheaves with larger bearing diameter for extended block life



## 21-22-23 STEEL SHELL BLOCKS FOR MANILA ROPE

- Same stock numbers
- Same working load limits
- Same fittings available
- Laser cut side plates
- Galvanized steel
- Grade 5 bolts secured with lock washers & staked nuts
- Replaceable wood bumpers
- Bronze bushed sheaves with larger bearing diameter for extended block life.



## 641- 642 DIAMOND PATTERN & 661-662 OVAL PATTERN BLOCKS

- Same stock numbers
- Same working load limits
- Same fittings available
- Laser cut side plates
- Grade 5 bolts secured with lock washers & staker nuts
- All sizes feature bronze bushed steel sheaves with larger bearing diameter for extended block life
- Lubricated center pin available upon request
- New style hanger for fitting attachment
  - Available with hanger only (on fitting) upon request



WESTERN & MARINE BLOCKS



## Regular Wood Blocks for Manila Rope

- Laser cut side plates
- Grade 5 bolts secured with lock washers and staked nuts.
- Bronze bushed sheaves with larger bearing diameter for extended block life.
- Becketts furnished on all blocks.
- For reeving information, see page 385.
- Meets or exceeds all requirements of ASME B30.26 including identification, ductility, design factor, proof load and temperature requirements. Importantly, these blocks meet other critical performance requirements including fatigue life, impact properties and material traceability, not addressed by ASME B30.26.



**HS-21-B**  
Regular Wood Block  
for Manila Rope

## HS-21B, 22B, 23B

Block Size (in.)	Fitting	Single Sheave 21 B Stock No.	Double Sheave 22 B Stock No.	Triple Sheave 23 B Stock No.
4	HS	603831	604634	605438
5	HS	603859	604652	605456
6	HS	603877	604670	605474
8	HS	603911	604714	605517
4	N	606437	606838	607230
5	N	606455	606856	607258
6	N	606473	606874	607276
8	N	606516	606918	607310
4	S	610039	611635	613232
5	S	610057	611653	613250
6	S	610075	611671	613278
8	S	610119	611715	613312

Fitting Type: HS-Latch Hook; N-Swivel Hook with Latch; S- Round Pin Anchor Shackle

## HS-21B, 22B, 23B

Block Size (in.)	Sheave Dimensions (mm)			Manila Rope Size (mm)	Working Load Limit (t)*			Weight Each (kg.)		
	Outside Diam.	Rim Thickness	Center Pin Diam.		21 Single	22 Double	23 Triple	21 Single	22 Double	23 Triple
4	57.0	16.0	9.65	13	.45	.64	.82	.79	1.36	1.81
5	76.0	19.1	9.65	16	.54	.82	1.09	1.47	2.54	2.95
6	89.0	25.4	12.7	19	.82	1.13	1.45	2.27	3.86	5.22
8	121	28.7	16.0	22-26	1.27	1.72	2.18	5.90	6.35	9.75

\*Ultimate Load is 4 times the Working Load Limit



## Steel Shell Blocks for Manila Rope

- Laser cut side plates
- Grade 5 bolts secured with lock washers and staked nuts.
- Bronze bushed sheaves with larger bearing diameter for extended block life.
- New style hanger for fitting attachment.



**P-303-B**  
Steel Shell Block  
for Manila Rope

## P-301B, 302B, 303B

Block Size (in.)	Fitting	Single Sheave	Double Sheave	Triple Sheave
		301 B* Stock No.	302 B* Stock No.	303 B* Stock No.
4	HS	680971	681373	681774
6	HS	680999	681391	681792
8	HS	681015	681417	681818
4	N	682639	683031	683433
6	N	682675	683077	683479
8	N	-	683111	-
6	P	-	692673	694270
8	P	691111	692717	694314

\*Bearing Code: B- Self Lubricating Bronze Bushed. Fitting Type: HS- Latch Hook; N- Swivel Hook with Latch; P- Screw Pin Anchor Shackle

## P-303B, 302B, 303B

Block Size (in.)	Sheave Size (mm)		Manila Rope Size (mm)	Working Load Limit (t)*			Weight Each (kg.)		
	Outside Diam.	Rim Thickness		Single	Double	Triple	Single	Double	Triple
4	57.2	16.0	13	.50	.73	1.00	1.02	1.70	2.27
6	89.0	25.4	19	.91	1.50	1.81	2.49	4.20	5.67
8	121	28.7	26	1.50	2.31	3.18	4.54	7.48	9.98

\*Ultimate Load is 3.5 times the Working Load Limit



# Western Standard Steel Blocks



## Loose Side Hooks with Latch for Manila Rope

- Laser cut side plates
- Grade 5 bolts secured with lock washers and staked nuts.
- Bronze bushed sheaves with larger bearing diameter for extended block life.

### HS-261, 262, 263

Block Size (in.)	Fitting	Manila Rope Size (mm)	Sheave Size		261 B Stock No.	262 B Stock No.	263 B Stock No.	Working Load Limit (t)*			Weight Each (kg)		
			Outside Diam.	Rim Thickness				261 Single	262 Double	263 Triple	261 Single	262 Double	263 Triple
4	HS	13	57.0	16.0	666826	666229	667228	.41	.64	.82	.63	1.46	1.47
5	HS	16	76.0	19.1	666844	666247	-	.54	.82	-	1.02	1.76	-
6	HS	19	89.0	25.4	666862	666265	-	.82	1.13	-	1.70	2.72	-
8	HS	22-26	121	28.7	666906	666309	667308	1.27	1.72	2.18	3.23	4.88	6.69

\*Ultimate Load is 3 times the Working Load Limit. Fitting Type : HS - Latch Hook



## Blocks for Synthetic Fiber Rope with loose swivel hooks

- These blocks are built to carry the increased loads of synthetic fiber ropes.
- All hooks are heat-treated alloy steel.
- You can now use a smaller size rope, and in turn, a smaller block, providing capacities which were previously not possible.
- Meets or exceeds all requirements of ASME B30.26 including identification, ductility, design factor, proof load and temperature requirements. Importantly, these blocks meet other critical performance requirements including fatigue life, impact properties and material traceability, not addressed by ASME B30.26.

### N-411B, 412B, 413B

Block Size (in.)	Fitting	411 B* Stock No.	412 B* Stock No.	413 B* Stock No.
4	S	755105	755301	755506
6	S	755123	755329	755524
4	N	757103	757309	757504
6	N	757121	757327	757522

\*Bearing Code: B- Self Lubricating Bronze Bushed. Fitting Type: S- Round Pin Anchor; N- Swivel Hook Latch

### N-411B, 412B, 413B

Block Size (in.)	Fitting	Sheave Size (mm)			Synthetic Rope Size (mm)	Working Load Limit (t)*			Weight Each (kg)		
		Outside Diam.	Rim Thickness	Center Pin Diam.		Single	Double	Triple	Single	Double	Triple
4	S	57.2	15.8	9.65	13	.90	1.36	1.36	1.36	1.81	2.72
6	S	89.0	25.4	12.7	19	1.36	3.18	3.63	2.83	4.54	6.35
4	N	57.2	15.8	9.65	13	.91	1.36	1.36	1.36	1.81	2.72
6	N	89.0	25.4	12.7	19	1.36	1.81	2.72	2.83	4.54	6.35

\*Ultimate Load is 4 times the Working Load Limit



HW-261B

- For 10 mm diameter wire cable.
- Sheave Size: 76 x 19 x 10mm.

HW-262B



### HW-261B, HW-262B

Block Size (in.)	Fitting	Block Stock No.	Catalog No.	Bearing Type	Wire Rope Size (mm)	Working Load Limit (t)*	Weight Each (kg)
5	H	665444	HW261-B	Bronze Bushed	10	.54	.91
5	H	665462	HW262-B	Bronze Bushed	10	.82	1.81

\*Ultimate Load is 3 times the Working Load Limit. Fitting Type : H - Swivel Hook

**STEEL SHELL & WOOD SHELL**



**T-390**  
Painted



**T-390**  
Galvanized



**T-385**  
Painted



**T-385**  
Galvanized

- New style blocks feature higher working load limits.
- Painted or Galvanized steel with replaceable wood bumpers.
- Laser cut side plate opens for insertion of wire rope.
- Incorporates exclusive bolt retaining spring to assure no lost bolts, plus utilizes secondary retaining pin.
- Bronze bushed sheaves with larger bearing diameter for extended block life.

- Utilizes Crosby "N" style hooks with integrated latch.
- Lubricated center pin.
- 10" and 12" sizes utilize steel sheaves.
- Meets or exceeds all requirements of ASME B30.26 including identification, ductility, design factor, proof load and temperature requirements. Importantly, these blocks meet other critical performance requirements including fatigue life, impact properties and material traceability, not addressed by ASME B30.26.



**385B, 390B Blocks**

Block Size (in.)	Fitting	Wood Shell		Steel Shell	
		385-B* Stock No. S.C.	385-B* Stock No. Galv.	390-B* Stock No. S.C.	390-B* Stock No. Galv.
6	T	702000	702108	702216	702324
8	T	702009	702117	702225	702333
10	T	702018	702126	702234	702342
12	T	702027	702135	702243	702351
6	J	702036	702144	702252	702360
8	J	702045	702153	702261	702369
10	J	702054	702162	702270	702378
12	J	702063	702171	702279	702387
6	G	702072	702180	702288	702396
8	G	702081	702189	702297	702405
10	G	702090	702198	702306	702414
12	G	702099	702207	702315	702423

\*Bearing Code : B - Self Lubricating Bronze Bushed; C - Common Iron; R - Roller Bearing  
Fitting Type : T - Swivel Latch Hook; J - Yoke and Oblong Swivel Eye; G - Yoke and Swivel Shackle

**385B, 390B Blocks**

Block Size (in.)	Sheave Size (mm)			Manila Rope Size (mm)	Drop Side	
	Outside Diam.	Rim Thickness	Bearing Diameter		Working Load Limit (t)*	Weight Each (kg.)
6	76.2	22.4	19.1	19-22	1.8	3.18
8	102	35.1	25.4	25-28	3.6	5.90
10	152	41.1	38.1	32	7.3	11.3
12	203	41.1	38.1	38	7.3	15.4

\*Ultimate Load is 4 times the Working Load Limit.

# Western Blocks for Manila Rope



**T-350-C**  
Gin Block

## Gin Blocks for Manila Rope

- For light hoisting by Roofers and Contractors.
- Furnished with drop forged swivel latch hooks.

## 350B, 350C, 350R

Block Size (in.)	Fitting	Gin Block Stock No.			Sheave Size (mm)			Manila Rope Size (mm)	Working Load Limit (t)*	Weight Each (kg)
		T-350-B	T-350-R	T-350-C	Outside Diam.	Rim Thickness	Bearing Diam.			
8	T	710403	710207	710001	203	31.8	19.1	22	.45	4.10
10	T	710421	710225	710029	254	31.8	22.4	26	.45	5.45
12	T	710449	710243	710047	305	35.1	22.4	26	.45	7.25

\*Ultimate Load is 3 times the Working Load Limit.

Bearing Code : B - Self Lubricating Bronze Bushed; R - Roller Bearing; C - Common Iron  
Fitting Type : T - Swivel Latch Hook



**HS-130-B**  
Single

## Painter's Supply Blocks for Manila Rope

- Furnished in Bronze Bushed.
- For 3/4" (19mm) Manila Rope.
- Steel Parts are Galvanized.
- Furnished with Loose Side Hooks with Latch or Shackle.
- Meets or exceeds all requirements of ASME B30.26 including identification, ductility, design factor, proof load and temperature requirements. Importantly, these blocks meet other critical performance requirements including fatigue life, impact properties and material traceability, not addressed by ASME B30.26.

## HS-130B, HS-135B, P-135B Gin Blocks for Manila Rope

Block Size (in.)	Fitting	Single Sheave Blocks	Double Sheave Blocks	
		HS-130 B* Stock No.	HS-135 B* Stock No.	P-135 B* Stock No.
6	HS	601236	631034	-
6	HS	-	-	8004829

\*Bearing Code : B - Self Lubricating Bronze Bushed  
Fitting Type : HS - Latch Hook

## HS-130B, HS-135B, P-135B

Block Size (in.)	Sheave Size (mm)			Manila Rope Size (in.)	Resultant Working Load Limit (t)*		Weight Each (kg)	
	Outside Diam.	Rim Thickness	Center Pin Dia.		130 Single	135 Double	130 Single	135 Double
					89.0	25.4	19.1	19

\*Ultimate Load is 4 times the Resultant Working Load Limit.



**DIAMOND & OVAL PATTERN REGULAR WIRE ROPE BLOCKS**



**T-641-B**  
Diamond Pattern  
Wire Rope Block

**661B**  
Oval Pattern  
Wire Rope Block



- Laser cut painted side plates (can be furnished galvanized upon request).
- Grade 5 bolts secured with lock washers and staked nuts.
- All sizes feature bronze bushed steel sheaves with larger bearing diameter for extended block life.
- New style hanger for fitting attachment
- Available with hanger only (no fitting).
- For reeving information, see page 385.
- Meets or exceeds all requirements of ASME B30.26 including identification, ductility, design factor, proof load and temperature requirements. Importantly, these blocks meet other critical performance requirements including fatigue life, impact properties and material traceability, not addressed by ASME B30.26.



**Diamond & Oval Pattern Regular Wire Rope Blocks**

Block Size (in.)	Fitting	Diamond Pattern with Bronze Bushed Steel Sheaves		Oval Pattern with Bronze Bushed Steel Sheaves	
		641-B Single	642-B Double	661-B Single	662-B Double
4	T	781586	782193	791183	791593
6	T	781611	782219	791218	791619
8	T	781639	782237	791236	791637
10	T	781657	782255	791254	791655
4	S	785886	786199	795884	796197
6	S	785902	786206	795900	796204
8	S	785920	786224	795928	796222
10	S	785948	786242	795946	796240
6	J	782102	782503	791502	791904
8	J	782120	782521	791520	791922
10	J	782148	782549	791548	791940
6	E	782004	782406	791307	791708
8	E	782022	782424	791325	791726
10	E	782040	782442	791343	791744

\*Fitting Type : T - Hook with Latch; S - Round Pin Shackle; J - Oblong Eye; E - Swivel Shackle Eye

**Diamond & Oval Pattern Regular Wire Rope Blocks**

Block Size (in.)	Sheave Size (mm)		Wire Rope Size (mm)	Working Load Limit (t)*		Weight Each (kg)	
	Outside Diam.	Rim Thickness		641 661 Single	642 662 Double	641 661 Single	642 662 Double
4	102	19.1	10	.91	1.82	3.6	5.0
6	152	25.4	10	2.72	3.63	6.8	9.5
8	203	31.8	16	3.63	5.44	12.7	18.6
10	254	31.8	16	3.63	6.35	17.2	27.2

\*Ultimate Load is 4 times the Working Load Limit

# McKissick® Trawl & Try Net Blocks



**J-452**  
Oblong Swivel  
Eye

## Double Rig Trawl Blocks

- Steel sheave with flame hardened groove, for maximum wear under abrasive conditions.
- Double row, permanently sealed tapered roller bearings.
- Pressure lubrication throughout.
- All steel construction.
- Hot Dip galvanized.



## J-452 Blocks

Sheave Dia. and Block No.	452 Stock No.	Working Load Limit (t)*	Weight Each (kg)	Sheave Dimensions (mm)	
				Outside Diam.	Rim Thickness
8" J-452	130655	9.07	21.8	203	95.5
12" J-452	130673	9.07	38.6	305	95.5
16" F-452	130682	18.14	53.0	406	95.5
18" J-452	2015467	22.50	136	457	138
22" F-452	130708	27.22	109	559	95.5

\*Ultimate Load is 4 times the Working Load Limit. NOTE: 18" J-452 utilizes a Manganese Steel Sheave that is not flame hardened.

## TRY NET BLOCKS



**F-453 6"**



**F-454 6"**



**J-454 8"**

- Forged steel swivel eyes.
- Hot Dip galvanized.
- 6" 453 - Pressed steel side plates with flared edges. Figure 8 grooved, self-lubricating bronze bushed sheaves, with pressure lube fittings. 453 has an extra wide throat opening to allow fittings to pass through.
- 6" 454 - Forged side plates designed to eliminate rope jamming. Wide throat opening and pressure lube fitting on sheave and eye fitting.
- 8" 454 - Forged steel side plates designed to eliminate possibility of rope jamming. Furnished with sealed tapered bearings. Flame hardened forged steel sheaves for wear resistance.

## 453, 454 Blocks

Sheave Dia. and Block No.	Bearing Type	Try Net Block Stock No.	Working Load Limit (t)*	Weight Each (kg)	Sheave Dimensions (mm)	
					Outside Diameter	Rim Thickness
6" F-453	Bronze Bushed	769886	4.54	15.9	152	70.0
6" F-454	Needle Bearing	2001763	4.54	10.4	152	70.0
8" J-454	Tapered Bearing	130726	9.07	16.3	203	73.0

\*Ultimate Load is 4 times the Working Load Limit.

**CARGO HOISTING BLOCKS**

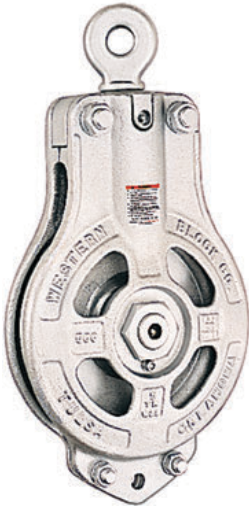

**E-566**  
with Drilled Swivel Eye

- 566 Cargo Hoisting Blocks**
- Block is galvanized.
  - Blocks 356mm and larger have flame-hardened roll forged sheaves that assure greater wire life.
  - Roll forged sheave is fitted closely into mortise of shell so wire cannot jam between sheave and shell.
  - Available for 19mm or 25mm wire.
  - Block is fitted with tapered roller bearings which take both load and side thrusts and hold sheave central so it cannot chafe or wear on the sides.
  - Tapered Roller bearing with neoprene seals and stainless steel center pin provide long life and trouble-free service.
  - Stainless steel center pin has recessed nuts with lock washers.
  - Swivel fitting has permanently sealed thrust bearing.
  - Pressure lubrication fittings are standard on both center pin and swivel.
  - Individually Proof Tested at 4 times Working Load or 2 times Resultant Load.
  - A.B.S. recognized load test certificates are furnished.
  - The Working Load for cargo hoisting blocks is the line pull.



**J-566**  
with Oblong Swivel Eye



**566 Blocks**

Sheave Size (mm)	Block No.	566 Stock No.	Working Load Limit (t)*	Wire Rope Size (mm)	Weight Each (kg)
305	E-566	775003	4.54	19	43.1
305	J-566	775209	4.54	19	43.1
305	G-566	775405	4.54	19	43.1
305	K-566	775600	4.54	19	43.1
305	QG-566	775806	4.54	19	43.1
305	QK-566	776002	4.54	19	43.1
356	E-566	775058	9.07	19	45.4
356	J-566	775254	9.07	19	45.4
356	QG-566	775450	9.07	19	45.4
356	QK-566	775655	9.07	19	45.4
356	PG-566	775851	9.07	19	45.4
356	PK-566	776057	9.07	19	45.4
356	E-566	775067	9.07	25	45.4
356	J-566	775263	9.07	25	45.4
356	QG-566	775469	9.07	25	45.4
356	QK-566	775664	9.07	25	45.4
356	PG-566	775860	9.07	25	45.4
356	PK-566	776066	9.07	25	45.4
406	E-566	776609	9.07	19	59
406	J-566	776672	9.07	19	59
406	QG-566	776681	9.07	19	59
406	QK-566	776690	9.07	19	59
406	PG-566	776707	9.07	19	59
406	PK-566	776716	9.07	19	59
406	E-566	752956	9.07	25	59
406	J-566	752965	9.07	25	59
406	QG-566	752974	9.07	25	59
406	QK-566	752983	9.07	25	59
406	PG-566	752992	9.07	25	59
406	PK-566	753009	9.07	25	59

\*Working Load equals maximum single line pull. Resultant Load equals 2 times single line pull. Ultimate Load equals 5 times the Resultant Load.



# Fitting for Western Cargo Blocks

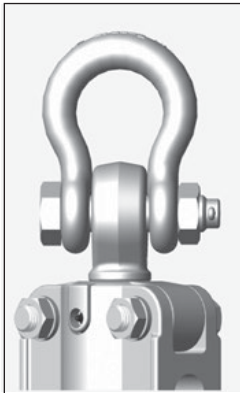

**QG**  
Swivel Bolt Type  
Shackle



**J**  
Oblong Swivel  
Eye



**QK**  
Upset Swivel  
Bolt Type



**U**  
Goose Neck  
Swivel Eye



**Z**  
Non-toppling  
Guard

## HEEL AND LEAD BLOCK ADJUSTER FITTINGS

(For use with E-566 Cargo Blocks)

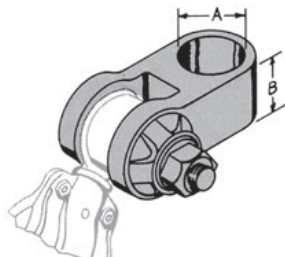

**No. 572**

Self-adjuster Fitting with Tension Pin, Cup Spring and Washers.

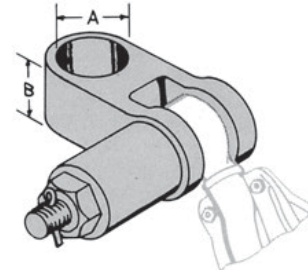

**No. 573**

Self-adjuster Fitting with Tension Pin, Coil Spring, Cup and Washers.

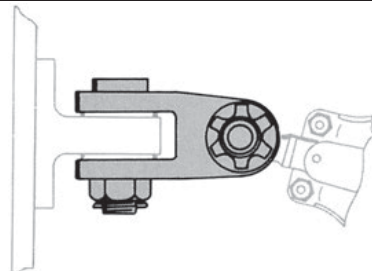

**No. 574**

Self-adjuster Fitting with Tension Pin, Cup Spring and Washers, and King Pin to fit Pad Eye (can also be furnished with 2 Tension Pins).

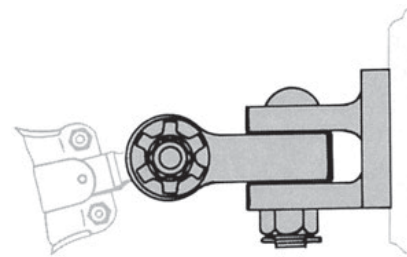

**No. 576**

Self-adjuster Fitting with Pad Jaw, King Pin, Tension Pin, Cup Spring and Washers.

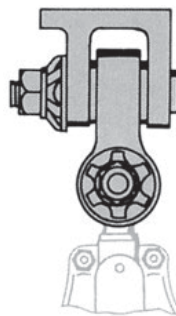

**No. 575**

Self-adjuster Fitting with Tension Pin, Cup Spring, and Washer.

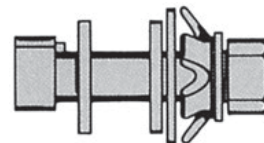

**No. 571**

Tension Pin with Cup Spring, Nut and Washers.

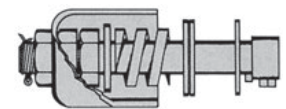

**No. 570**

Tension Pin with Coil Spring, Nut and Washers, Cotter and Cup.

When ordering Specify: "A" - Pin Diameter, "B" -Height of Fitting, and Tension Pin Diameter.



**S-600S**  
Horizontal Lead Blocks

### Horizontal Lead Blocks

- Available painted or galvanized.
- Fitted with steel sheaves.
- Self Lubricated Bronze Bushed.

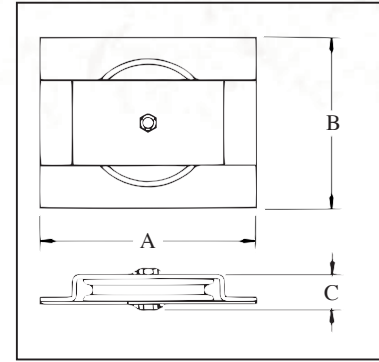

### S-600S / G-600S Horizontal Lead Blocks

Sheave Diameter (mm)	600 Series Stock No.		Resultant Working Load Limit (t)*	Wire Rope Size (mm)	Weight Each (kg)	Dimensions (mm)		
	S-600-S Painted	G-600-S Galv.				A	B	C
152	771999	772006	1.81	10	5.6	279	162	63.5
203	772015	772024	2.27	13	9.5	330	216	76.0
254	772033	772042	2.72	16	16.3	381	267	82.5
305	772051	772060	3.63	19	27.7	432	318	102
356	772079	772088	4.54	22	43.0	483	368	102

\*Ultimate Load is 4 times the Resultant Working Load Limit.



**S-601S**  
Vertical Lead Block

### Vertical Lead Blocks

- Available painted or galvanized.
- Fitted with steel sheaves.
- Self Lubricated Bronze Bushed.

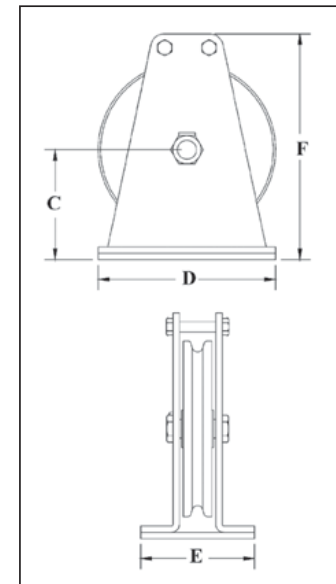

### S-601S / G-601S Vertical Lead Blocks

Sheave Diameter (mm)	601 Series Stock No.		Resultant Working Load Limit (t)*	Wire Rope Size (mm)	Weight Each (kg)	Dimensions (mm)			
	S-601-S Painted	G-601-S Galv.				C	D	E	F
6	772195	772202	6	10	4.5	89	152	140	178
8	772211	772220	8	13	11.0	124	203	171	248
10	772239	772248	10	16	14.3	162	254	197	298
12	772257	772266	12	19	27.2	184	305	152	387
14	2003424	2003425	14	22	44.5	222	356	229	457

\*Ultimate Load is 4 times the Resultant Working Load Limit.

# Western Lead Blocks



**G-602S**  
Flag Lead Block

## Flag Blocks

- Base plates are drilled.
- Available painted or galvanized.
- Fitted with steel sheaves.
- Self-lubricated Bronze Bushed.

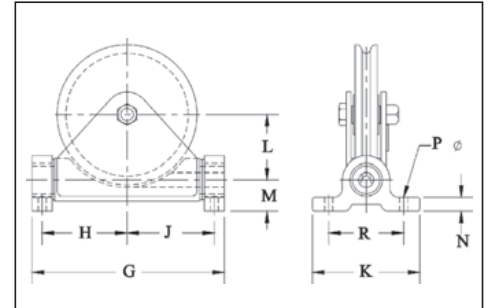

## S-602S / G-602S Flag Blocks

Sheave Diameter (mm)	602 Series Stock No.		Resultant Working Load Limit (t)*	Wire Rope Size (mm)	Weight Each (kg)	Dimensions (mm)								
	S-602-S Painted	G-602-S Galv.				G	H	J	K	L	M	N	P	R
152	772391	772408	1.81	10	7.71	229	95.5	98.5	159	73.0	41.1	19.1	14.2	121
203	1420885	772426	2.27	13	14.3	289	121	130	178	92.0	51.0	25.4	17.5	140
254	772435	772444	2.72	16	19.1	340	145	154	178	117	51.0	25.4	17.5	140
305	772453	772462	3.63	19	52	438	184	197	273	137	79.0	35.1	20.6	191
356	772471	-	4.54	22	62	489	216	222	273	165	79.0	35.1	20.6	191

\*Ultimate Load is 4 times the Resultant Working Load Limit.



**S-603S**  
Hinged Lead Block

## Hinged Lead Blocks

- Base plates are not drilled.
- Available painted or galvanized.
- Self-lubricated Bronze Bearings.

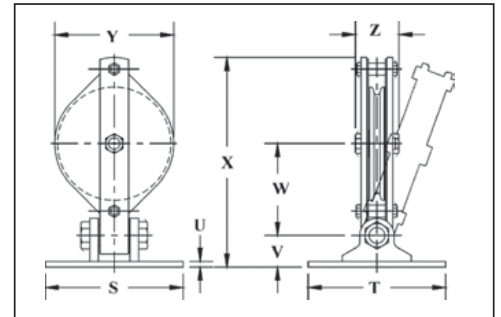

## S-603S / G-603S Hinged Lead Blocks

Sheave Diameter (mm)	603 Series Stock No.		Resultant Working Load Limit (t)*	Wire Rope Size (mm)	Weight Each (kg)	Dimensions (mm)							
	S-603-S Painted	G-603-S Galv.				S	T	U	V	W	X	Y	Z
152	772596	772603	1.81	10	13.6	152	114	12.7	51.0	148	325	171	82.5
203	772612	772621	2.27	13	15.4	203	171	9.65	66.5	167	393	229	95.5
254	772630	772649	2.72	16	20.4	305	305	12.7	70.0	203	464	273	111
305	772658	772667	3.63	19	34.0	305	305	12.7	70.0	241	473	330	116
356	772676	772685	4.54	22	45.4	305	305	12.7	70.0	273	524	381	122

\*Ultimate Load is 4 times the Resultant Working Load Limit.



## McKissick® Horizontal & Vertical Blocks

461 Vertical Lead Block

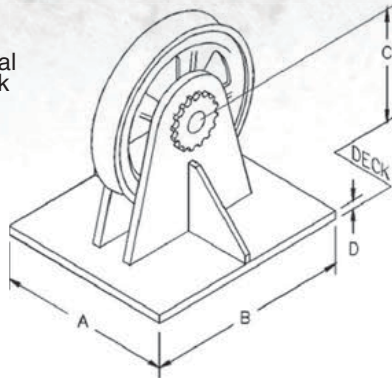

463 Horizontal Lead Block

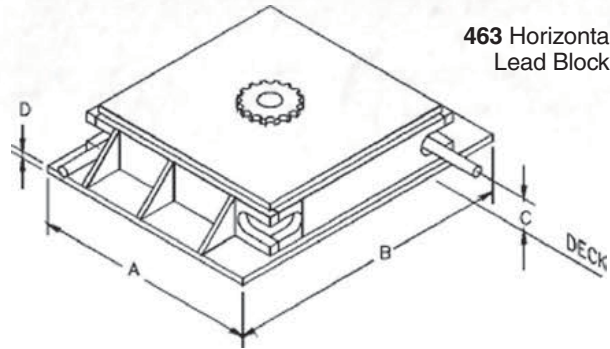

Furnish the following important information when ordering:

- A, B and C dimensions.
- Line pull in pounds and degree of wrap.
- Line speed.
- Diameter of wire rope.
- Roller bearings, bronze bushings, or sealed double row tapered bearings.

Guide and control your deck lines with McKissick's deck-mounted wire rope sheaves. Built to your specific requirements.

- Extra heavy construction, built to withstand breaking strength of indicated rope (XIP, IWRC).
- Flame-hardened sheaves, machined grooves for proper rope size.
- For special requirements contact Crosby.

### 461 Vertical & 463 Horizontal Lead Blocks

Figure No.	Lead Blocks Stock No.	Sheave Diameter (mm)	Standard Wire Rope Size (mm)	Weight Each (kg)	Dimensions (mm)			
					A	B	C	D
461-18	239753	457	22	227	305	508	279	38.1
461-24	131574	610	32	227	381	660	356	38.1
461-26	238120	660	38	299	406	711	381	38.1
461-36	148389	914	42	386	508	914	495	50.8
461-40	136285	1016	50	910	584	1067	572	50.8
461-42	130753	1067	64	1814	711	1321	648	63.5
463-26	4440359	660	26	448	838	838	95.5	38.1
463-30	1404377	762	32	556	940	940	89.0	38.1
463-36	146522	914	38	862	1092	1092	89.0	38.1
463-42	1406525	1067	44	1350	1270	1270	111	51.0
463-48	131583	1219	50	1630	1397	1397	118	51.0
463-60	123164	1524	64	2900	1727	1727	146	51.0

For custom orders contact our Block Hotline, (1-800-727-1555) or reference the special request form on pg 482.



457 Deck Mounted Anchor Fairleader

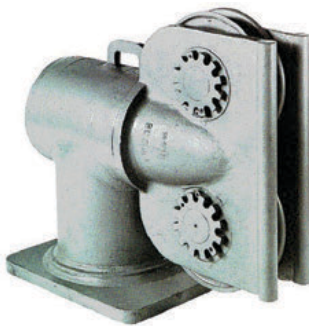

### Deck Mounted Anchor Fairleader

- Barrel and sheaves equipped with sealed double row tapered bearings.
- Extra heavy construction, built to withstand breaking strength of indicated rope at 90 degree sheave wrap and 45 degree head swing.
- All bearings Alemite-lubricated.
- Custom Anchor Fairleader sets available.

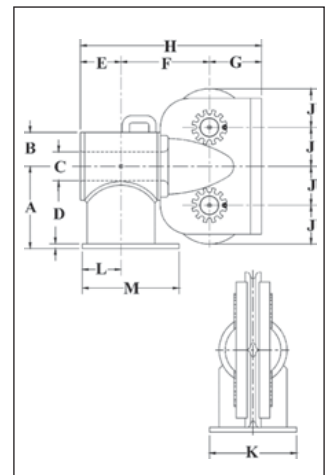

### 457 Deck Mounted Anchor Fairleader

Figure No.	457 Stock No.	Sheave Diameter (in.)	Wire Rope Size (in.)	Weight Each (kg)	Dimensions (mm)												
					A	B	C	D	E	F	G	H	J	K	L	M	
B-10-D	8073880	254	26	136	273	114	89.0	19.1	127	257	171	556	129	241	114	279	
B-12-D	8073924	305	32	272	324	127	127	19.1	162	314	203	679	154	279	133	330	
B-16-D	8073979	406	38	590	432	178	152	25.4	214	451	273	938	205	457	203	508	
B-20-D	8074022	508	44	1134	533	229	216	25.4	286	557	324	1167	256	533	254	622	
B-24-D	8074111	610	52	1633	641	279	254	31.8	324	673	375	1372	306	584	279	686	



## NEW STYPE OVAL PATTERN CONSTRUCTION BLOCKS



Q-681-Z



Q-682-Z



Q-683-Z

- All blocks are galvanized.
- Sheave lubricated through pressure lube fitting in center pin.
- Assembled with self lubricated bronze bushing.
- Combines weight of regular oval blocks with strength of extra heavy oval blocks.
- Assembled with bolt type anchor shackle.
- Side plates are rounded to provide additional stiffness and reduce wear and chaffing of the rope.

### Q-681-Z / Q-682-Z / Q-683-Z

Block Size (in.)	Fitting	Stock No. Bronze Bushed Steel Sheaves		
		Q-681-Z	Q-682-Z	Q-683-Z
6	Q	760441	760665	-
6	Q	760452	760676	760812
8	Q	760463	760687	760823
10	Q	760474	760698	760834

Fitting Type : Q - Bolt Type Anchor Shackle

### Q-681-Z / Q-682-Z / Q-683-Z

Block Size (mm)	Sheave Dimensions (mm)			Wire Rope Size (mm)	Working Load Limit (t)*			Weight Each (kg)		
	Outside Diam.	Rim Thickness	Center Pin Dia.		Single	Double	Triple	Single	Double	Triple
6	152	25.4	19.1	10	2.70	3.63	-	6.8	12.7	14.5
6	152	25.4	19.1	13	2.70	3.63	4.50	7.3	12.7	14.5
8	203	31.8	25.4	16	3.63	5.44	-	13.2	20.4	28.1
10	254	31.8	25.4	16	3.63	6.35	7.25	17.2	27.7	36.3

\*Ultimate Load is 4 times the Working Load Limit. Bearing Code: Z - Self Lubricating Bronze Bushed with pressure lube fitting.

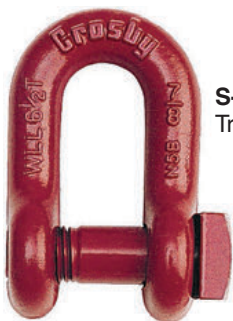

S-2131  
Trawling Shackles

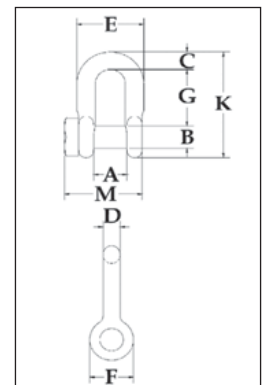

### S-2131 Trawling Shackles

Nominal Shackle Size D (in.)	Working Load Limit (t)*	S-2131 Stock No.	Weight Each (kg)	Dimensions (mm)										Tolerance +/-	
				A	B	C	D	E	F	G	K	M	G	A	
1/2	2	1018703	.34	20.6	16.0	12.7	12.7	46.0	30.2	41.4	78.5	56.5	3.30	1.50	
5/8	3-1/4	1018721	.56	27.0	19.1	16.0	16.0	58.5	39.6	51.0	96.0	70.0	3.30	1.50	
3/4	4-3/4	1018749	.99	31.8	22.4	20.6	19.1	70.0	47.8	60.5	114	82.5	6.35	1.50	
7/8	6-1/2	1018767	1.49	36.6	25.4	24.6	22.4	81.0	54.0	71.5	133	93.5	6.35	1.50	
1	8-1/2	1018785	2.27	42.9	28.7	25.4	26	93.5	60.5	81.0	151	108	6.35	1.50	
1-1/8	9-1/2	1018803	3.16	46.0	31.8	31.8	28	103	68.5	91.0	172	117	6.35	1.50	

\*Ultimate Load is 4 times the Working Load Limit.

**FOR MANILA OR WIRE ROPE BLOCKS**

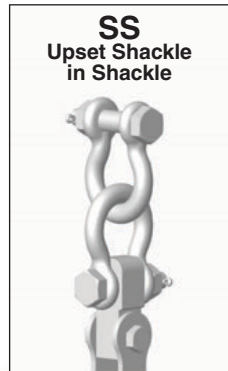
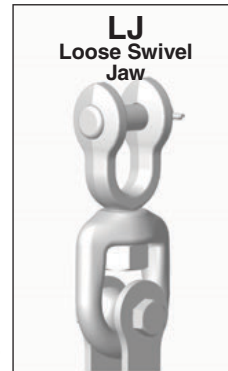
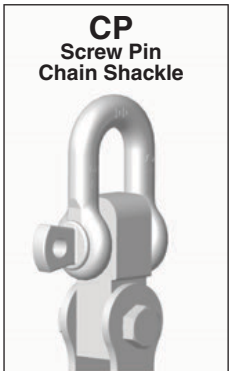
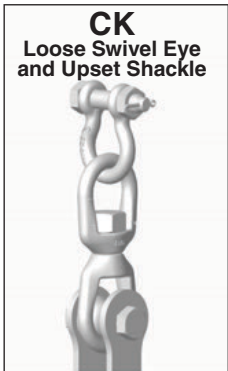
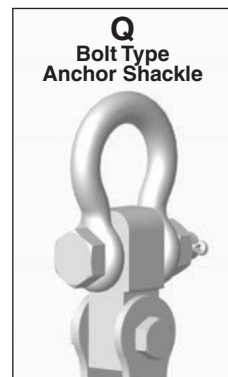
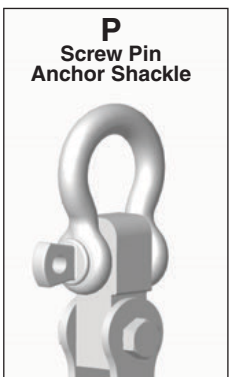
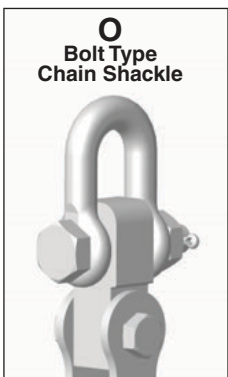
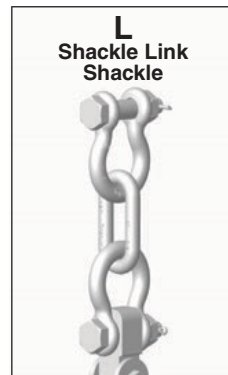
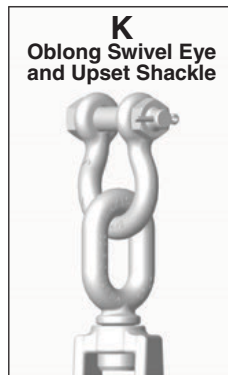
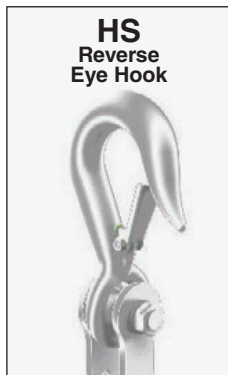
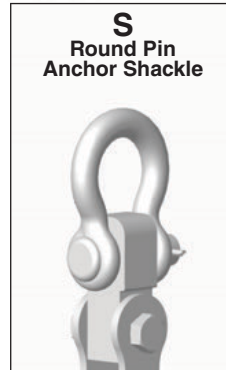





# CROSBY<sup>®</sup> LIFTING CLAMPS





**IPU10**

The IPU10 vertical lifting clamp is used for lifting, turning, moving or vertical transfer of sheet, plates, or fabrications from horizontal to vertical and down to horizontal (180°) as needed. The hinged hoisting eye allows for the clamp to place and lift the load from any direction, or with a multiple leg sling without side-loading the clamp.

## Universal - For Lifting in any Direction

- Available in capacities of .5 thru 30 metric tons (Higher Working Load Limits are available upon request).
- Wide variety of jaw openings available: 0" to 155mm.
- Welded alloy steel body for strength and smaller size. Forged alloy components, where required.
- Individually Proof Tested to 2 times the Working Load Limit with certification.
- Company name (CrosbyIP), logo, Working Load Limit and jaw opening permanently stamped on body.
- Each product is individually serialized, with the serial number and Proof Load test date stamped on body. User manual with test certificate is included with each clamp.
- Available in a variety of styles:
  - IP10 - Standard clamp for materials with a surface hardness to 363HV10 (345 HB).
  - IP10J - Larger jaw opening.
  - IP10S - For use with Stainless Steel material.
  - IP10H - For use with materials with a surface hardness to 472HV10 (450 HB).
- Full 180° turning range for material transfer, turning or moving.
- Lock open, lock closed ability with latch for pretension on material and then release of material.
- Optional IP-5000 Stinger assembly available (see page 428). Allows for easy connection between the clamp and hoist hook.
- Minimum WLL of 10% of Maximum WLL.
- Maintenance replacement kits are available.
- Manufactured by an ISO 9001 facility.
- All sizes are RFID EQUIPPED.



**IPU10S**

**IPU10S:** For use with Stainless Steel material.  
**IPU10H:** For use with materials with a surface hardness to 47Rc (450 HB).



**Load Rated**

## Model IPU10 / IPU10S / IPU10H

Model	Working Load Limit (t)*	IPU10 Stock No.	Weight Each (kg.)	Dimensions (mm)									
				Jaw A	B	C	D	E	F	G	H	J	K
IPU10	0.5	2701675	1.9	0 - 16	44	128	228	40	115	41	28	-	11
IPU10	1	2701663	2.4	0 - 20	45	139	222	40	126	41	38	-	11
IPU10	2	2701677	8.5	0 - 35	78	201	372	70	190	61	55	-	16
IPU10	3	2701665	14.8	0 - 40	100	253	445	75	225	78	60	-	20
IPU10	4.5	2701667	16.0	0 - 40	100	253	445	75	232	82	65	-	20
IPU10	6	2701669	24.0	0 - 50	126	302	525	80	292	84	95	44	20
IPU10J	6	2702469	30.5	50 - 100	126	302	525	80	342	84	95	44	20
IPU10	9	2701671	29.5	0 - 50	126	325	557	80	310	92	105	44	20
IPU10J	9	2701673	30.5	50 - 100	126	325	562	80	360	92	105	44	20
IPU10	12	2701679	57.0	0 - 54	160	391	623	80	331	117	137	41	25
IPU10J	12	2701681	59.0	54 - 108	178	439	673	80	415	117	137	41	25
IPU10	16	2701683	72.0	5 - 64	178	465	734	88	397	119	153	45	25
IPU10J	16	2701685	85.0	64 - 128	208	521	790	88	472	119	161	45	25
IPU10	22.5	2701687	127	5 - 80	222	554	855	110	470	136	186	49	25
IPU10J	22.5	2701689	130	80 - 155	253	628	930	110	575	136	196	49	25
IPU10	30	2701691	153	5 - 80	222	545	860	110	470	152	186	54	30
IPU10J	30	2701693	165	80 - 155	250	620	935	110	565	152	196	54	30
<b>For stainless steel - with universal hoisting eye</b>													
IPU10S	0.5	2702275	1.9	0 - 16	44	128	228	40	115	41	28	-	11
IPU10S	1	2702263	2.1	0 - 20	45	139	222	40	126	41	38	-	11
IPU10S	2	2702277	7.6	0 - 35	78	201	372	70	190	61	55	-	16
IPU10S	3	2702265	14.8	0 - 40	100	253	445	75	225	78	60	-	20
IPU10S	4.5	2702267	16.0	0 - 40	100	253	445	75	232	82	65	-	20
IPU10S	6	2702269	24.0	0 - 50	126	302	525	80	292	84	95	44	20
IPU10S	9	2702271	29.5	0 - 50	126	325	557	80	310	92	105	44	20
IPU10S	12	2702279	30.5	0 - 54	160	391	623	80	331	117	137	41	25
<b>For very hard materials - with universal hoisting eye</b>													
IPU10H	0.5	2702175	1.9	0 - 16	44	128	228	40	115	41	28	-	11
IPU10H	1	2702177	7.6	0 - 35	78	201	372	70	190	61	55	-	16
IPU10H	2	2702165	14.8	0 - 40	100	253	445	75	225	78	60	-	20
IPU10H	3	2702167	16.0	0 - 40	100	253	445	75	232	82	65	-	20
IPU10H	4.5	2702169	24.0	0 - 50	126	302	525	80	292	84	95	44	20
IPU10/H	6	2702171	29.5	0 - 50	126	325	557	80	310	92	105	44	20

\* Design Factor based on EN 13155 and ASME B30.20. Model IP10R (remote control opening and closing via a cable) on request. Model IPU10W (wedge) available on request.

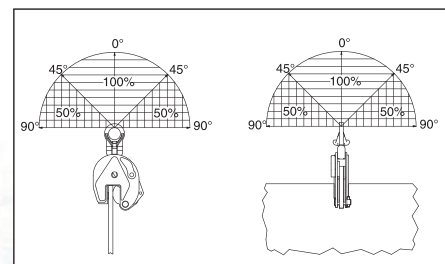
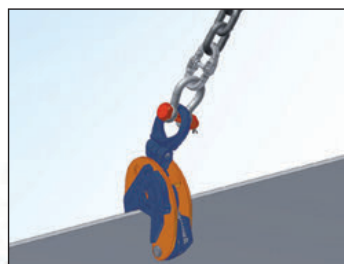
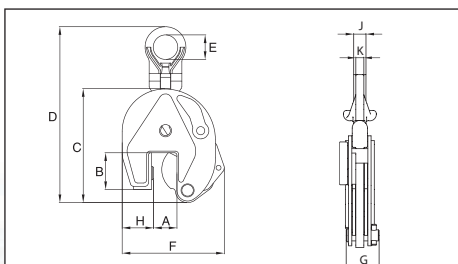

# Vertical Clamps



**IP10**

The IP10 vertical lifting clamp is used for the lifting, turning, moving or vertical transfer of sheet, plates, or fabrications from horizontal to vertical and down to horizontal (180°) as needed. Usually used as a single point pick or when used with a spreader beam with multiple vertical drop lines.

## For Vertical Lifting, Turning and Transfer

- Available in capacities of .5 thru 30 metric tons (Higher Working Load Limits are available upon request).
- Wide variety of jaw openings available: 0 to 155mm.
- Welded alloy steel body for strength and smaller size. Forged alloy components, where required.
- Individually Proof Tested to 2 times the Working Load Limit with certification.
- Company name (CrosbyIP), logo, Working Load Limit and jaw opening permanently stamped on body.
- Each product is individually serialized, with the serial number and Proof Load test date stamped on body. Serial number is included on the test certificate with maintenance and warranty logbook.
- Available in a variety of styles:
  - IP10 - Standard clamp for materials with a surface hardness to 363HV10 (345 HB).
  - IP10J - Larger jaw opening.
  - IP10S - For use with Stainless Steel material.
  - IP10H - For use with materials with a surface hardness to 472HV10 (450 HB).
- Full 180° turning range for material transfer, turning or moving.
- Lock open, lock closed ability with latch for pretension on material and then release of material.
- Optional IP-5000 Stinger assembly available (see page 428). Allows for easy connection between the clamp and hoist hook.
- Minimum WLL of 10% of Maximum WLL.
- Maintenance replacement kits are available.
- Manufactured by an ISO 9001 facility.
- All sizes are **RFID EQUIPPED**

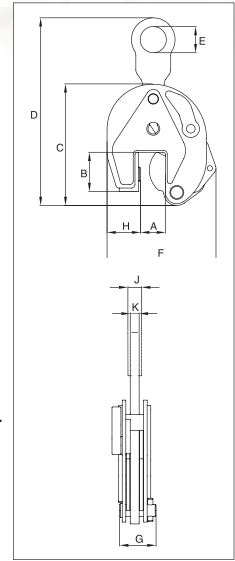

## Model IP10

Model	Working Load Limit (t)*	IP10 Stock No.	Weight Each (kg)	Dimensions (mm)										
				Jaw A	B	C	D	E	F	G	H	J	K	
IP10	0.5	2701674	1.8	0 - 16	44	128	207	30	115	41	28	-	10	
IP10	1	2701662	2.2	0 - 20	45	139	215	30	126	41	38	-	10	
IP10	2	2701676	7.6	0 - 35	78	201	336	70	190	61	55	-	16	
IP10	3	2701664	13.8	0 - 40	100	253	436	75	225	78	60	-	20	
IP10	4.5	2701666	15.0	0 - 40	100	253	436	75	232	82	65	-	20	
IP10	6	2701668	23.5	0 - 50	126	302	515	80	292	84	95	40	20	
IP10J	6	2701705	28.5	50 - 100	126	302	515	80	342	84	95	40	20	
IP10	9	2701670	27.5	0 - 50	126	325	550	80	310	92	105	44	25	
IP10J	9	2701672	28.5	50 - 100	126	325	555	80	360	92	105	44	25	
IP10	12	2701678	49.0	0 - 54	160	391	580	80	331	117	137	41	25	
IP10J	12	2701680	58.0	54 - 108	178	439	630	80	415	117	137	41	25	
IP10	16	2701682	68.0	5 - 64	178	465	690	88	397	119	153	49	25	
IP10J	16	2701684	90.0	64 - 128	208	521	746	88	472	119	161	49	25	
IP10	22.5	2701686	108	5 - 80	222	554	800	110	470	136	186	49	25	
IP10J	22.5	2701688	110	80 - 155	253	628	880	110	575	136	196	49	25	
IP10	30	2701690	148	5 - 80	222	545	800	110	470	152	186	54	30	
IP10J	30	2701692	152	80 - 155	250	620	880	110	565	152	196	54	30	
<b>For stainless steel - with fixed hoisting eye</b>														
IP10S	0.5	2702274	1.8	0 - 16	44	128	207	30	115	41	28	-	10	
IP10S	1	2702262	2.0	0 - 20	45	139	215	30	126	41	38	-	10	
IP10S	2	2702276	6.8	0 - 35	78	201	336	70	190	61	55	-	16	
IP10S	3	2702264	13.8	0 - 40	100	253	436	75	225	78	60	-	20	
IP10S	4.5	2702266	15.0	0 - 40	100	253	436	75	232	82	65	-	20	
IP10S	6	2702268	23.5	0 - 50	126	302	525	80	292	84	95	40	20	
IP10S	9	2702270	27.5	0 - 50	126	325	557	80	310	92	105	44	25	
IP10S	12	2702278	49.0	0 - 54	160	391	623	80	331	117	137	41	25	
<b>For very hard materials - with fixed hoisting eye</b>														
IP10H	0.5	2702174	1.8	0 - 16	44	128	207	30	115	41	28	-	10	
IP10H	1	2702176	6.8	0 - 35	78	201	336	70	190	61	55	-	10	
IP10H	2	2702164	13.8	0 - 40	100	253	436	75	225	78	60	-	16	
IP10H	3	2702166	15.0	0 - 40	100	253	436	75	232	82	65	-	20	
IP10H	4.5	2702168	23.5	0 - 50	126	302	515	80	292	84	95	40	20	
IP10H	6	2702170	27.5	0 - 50	126	325	550	80	310	92	105	44	25	

\* Design Factor based on EN 13155 and ASME B30.20. Model IP10R (remote control opening and closing via a cable) on request. Not for USA.

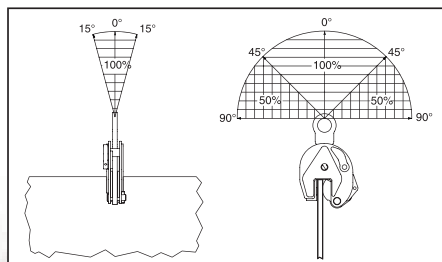

**CROSBY® LIFTING CLAMPS**





IPNM10N

The IPNM10N vertical lifting clamp is used for lifting, turning, moving or vertical transfer of sheet, plates, or fabrications from horizontal to vertical and down to horizontal (180°) as needed without marring the surface of the material. Materials such as aluminum, stainless steel, painted materials, aircraft skins, composite material, glass, plastic, etc., can be lifted without marring.

Will NOT mar, or scratch the material surface.

For use in almost all sectors of industry where during the lift or transfer, no damage to the material is permitted.

- Available in capacities of .5 , 1 and 2 metric tons.
- Wide variety of jaw openings available: 0 to 40mm.
- Welded alloy steel body for strength and smaller size. Forged alloy components, where required.
- Individually Proof Tested to 2 times the Working Load Limit with certification.
- Company name (CrosbyIP), logo, Working Load Limit and jaw opening permanently stamped on body.
- Each product is individually serialized, with the serial number and Proof Load test date stamped on body. User manual with test certificate is included with each clamp.
- Full 180° turning range for material transfer, turning or moving.
- Lock open, lock closed ability with latch for pretension on material and then release of material.
- Optional IP-5000 Stinger assembly available (see page 428). Allows for easy connection between the clamp and hoist hook.
- Material must be clean and dry.
- Maintenance replacement kits are available.
- Manufactured by an ISO 9001 facility.
- All sizes are **RFID EQUIPPED**.



IPNM10P

The IPNM10P vertical lifting clamp is used for lifting, turning, moving or vertical transfer of sheet, plates, or fabrications from horizontal to vertical and down to horizontal (180°) as needed without marring the surface of the material. Materials such as aluminum, stainless steel, painted materials, aircraft skins, composite material, glass, plastic, etc., can be lifted without marring. The protective cover reduces the risk of damage to surrounding plates.

Will NOT mar, or scratch the material surface.



Load Rated

Model IPNM10

Model	Working Load Limit (t)*	IPNM10 Stock No.	Weight Each (kg)	Dimensions (mm)								
				Jaw A	B	C	D	E	F	G	H	K
IPNM10N	.5	2703811	2.7	0 - 10	84	159	235	40	128	60	41	11
IPNM10N	1	2703738	4.4	0 - 20	110	209	270	30	134	80	56	10
IPNM10	2	2703442	14.5	0 - 40	153	258	396	70	196	100	16	16
<b>With protection cap</b>												
IPNM10P	.5	2703278	2.8	0 - 10	82	157	213	40	145	68	48	11
IPNM10P	1	2703279	4.5	0 - 20	97	195	268	30	205	82	60	10
<b>With larger jaw opening</b>												
IPNM10NJ	1	2703814	5.5	20 - 37	86	196	265	30	177	80	51	10

\* Design Factor based on EN 13155 and ASME B30.20.

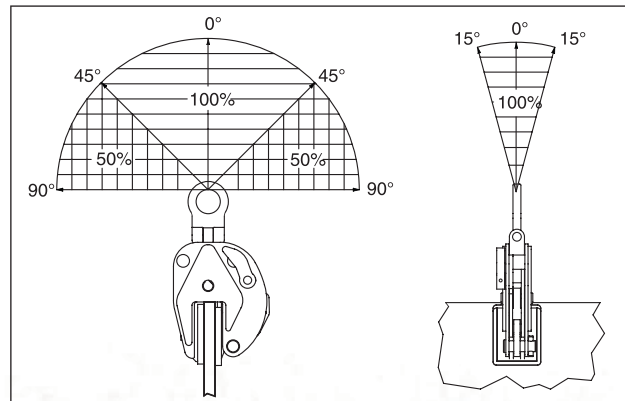
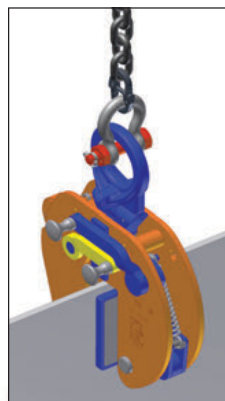
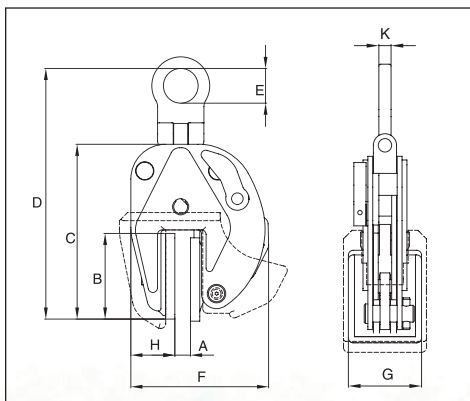

# Vertical Clamps



**IPU10/A**

The IPU10/A automatically clicks on to the material as soon as the clamp is placed on the plate. The fact that the safety lock remains in position as the clamp closes precludes hazardous situations. Fastening the IPU10/A clamp in places that are difficult to reach is no problem.

## For vertical transport of plates

- Available in capacities of 1 and 2 metric tons.
- Jaw openings available: 0 to 35mm.
- Welded steel body for strength and smaller size. Forged alloy components where required.
- Individually Proof Tested to 2 times the Working Load Limit with certification.
- Company name (CrosbyIP), logo, Working Load Limit and jaw opening permanently stamped on body.
- Each product is individually serialized, with the serial number and Proof Load test date stamped on body. User manual with test certificate is included with each clamp.
- Full 180° turning range for material transfer, turning or moving.
- Lock open, lock closed ability with latch for pretension on material and then release of material.
- Optional IP-5000 Stinger assembly available (see page 428). Allows for easy connection between the clamp and hoist hook.
- Minimum WLL of 10% of Maximum WLL.
- Maintenance replacement parts are available.
- Manufactured by an ISO 9001 facility.
- All sizes are **RFID EQUIPPED**.

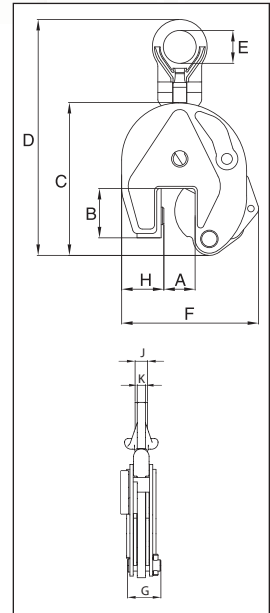

**Load Rated**

## Model IPU10/A

Model	Working Load Limit (t)*	IPU10/A Stock No.	Weight Each (kg)	Dimensions (mm)								
				Jaw A	B	C	D	E	F	G	H	K
IPU10/A	1	2701628	2.3	0 - 20	45	138	238	40	128	41	37	11
IPU10/A	2	2701629	8.9	0 - 35	78	201	378	70	200	61	72	16

\* Design Factor based on EN 13155 and ASME B30.20.

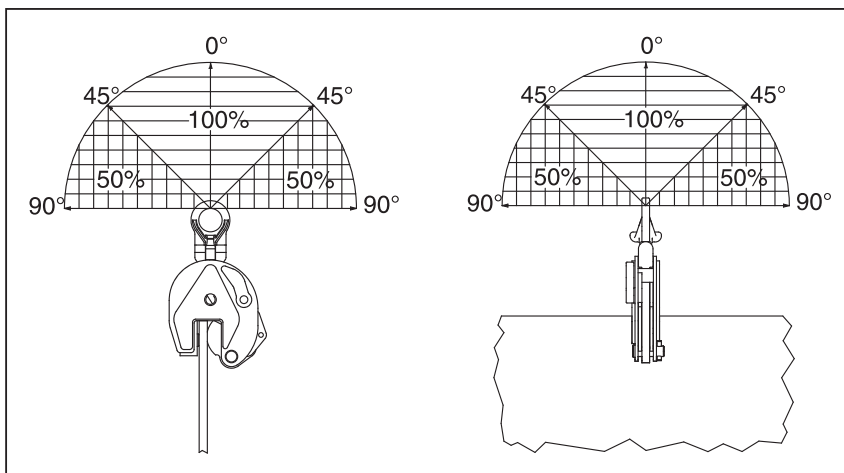

**CROSBY® LIFTING CLAMPS**

# Horizontal Clamps



**IPHNM10**

The IPHNM10 horizontal lifting clamps have a pretension feature that allows the user to attach the clamps to the material for horizontal lifting and transfer of non-sagging material. To be used where material surface must not be damaged. These clamps must be used in pairs or more.

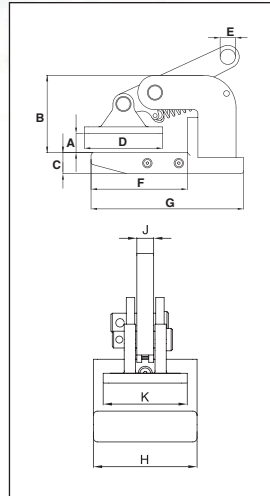

**IPH10**

The IPH10 horizontal lifting clamps with spring loaded tension have a pretension feature that allows the user to attach the clamps to the material for horizontal lifting and transfer of non-sagging material. These clamps must be used in pairs or more.

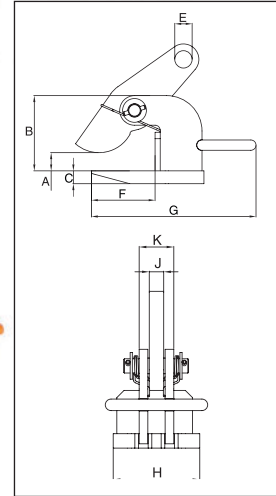

## For Horizontal Lift and Transfer with Pretension System

- Available in capacities of .5 thru 12 metric tons.
- Jaw openings available: 0 to 120mm.
- Welded alloy steel body for strength and smaller size. Forged alloy components, where required.
- Individually Proof Tested to 2 times the Working Load Limit with certification.
- Company name (Crosby/IP), logo, Working Load Limit and jaw opening permanently stamped on body.
- Each product is individually serialized, with the serial number and Proof Load test date stamped on body. User manual with test certificate is included with each clamp.
- Maintenance replacement parts are available.
- Manufactured by a ISO 9001 facility.
- All sizes are **RFID EQUIPPED**.



**Load Rated**

### Model IPHNM10

Model	Working Load Limit (Per Pair) (t)*	IPHNM10 Stock No.	Weight Each (kg)	Dimensions (mm)									
				Jaw A	B	C	D	E	F	G	H	J	K
IPHNM10	.5	2703287	2.0	0 - 20	81	22	82	16	101	160	74	12	60
IPHNM10	1	2703288	3.5	0 - 35	93	30	92	16	103	164	74	12	60
IPHNM10	2	2703290	7.5	0 - 30	139	30	131	22	166	245	100	20	74
IPHNM10/J	2	2703291	8.0	30 - 60	169	30	131	22	166	245	100	20	74

\* Design Factor based on EN 13155 and ASME B30.20.

### Model IPH10 and IPH10/J: With Spring Loaded Tension, Magnets and Handle

Model	Working Load Limit (Per Pair) (t)*	IPH10 Stock No.	Weight Each (kg)	Dimensions (mm)									
				Jaw A	B	C	E	F	G	H	J	K	
IPH10	.5+	2703297	1.8	0 - 20	86	12	16	103	150	60	12	27	
IPH10	1+	2703298	2.5	0 - 35	100	16	16	103	150	60	12	31	
IPH10	2	2703522	5.5	0 - 60	117	16	22	109	256	110	20	40	
IPH10	3	2703523	7.5	0 - 60	117	20	26	109	266	120	20	48	
IPH10	4.5	2703524	10.5	0 - 60	132	25	30	104	280	130	20	48	
IPH10	6	2703525	13.0	0 - 60	143	25	36	123	320	130	20	48	
IPH10	9	2703526	18.5	0 - 60	157	30	43	133	330	140	25	62	
IPH10	12	2703527	21.5	0 - 60	172	30	47	141	353	150	25	62	
<b>With larger jaw opening #</b>													
IPH10/J	3	2703533	9.0	60 - 120	177	20	26	109	266	120	20	48	
IPH10/J	4.5	2703534	12.0	60 - 120	192	25	30	104	280	130	20	48	
IPH10/J	6	2703535	15.0	60 - 120	203	25	36	123	320	130	20	48	
IPH10/J	9	2703536	20.5	60 - 120	217	30	43	133	330	140	25	62	
IPH10/J	12	2703537	24.0	60 - 120	232	30	47	141	353	150	25	62	

\* Design Factor based on EN 13155 and ASME B30.20. + No handle or magnets. # Larger Working Load Limits available.

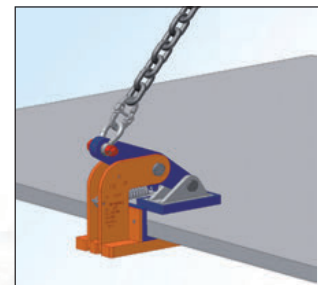
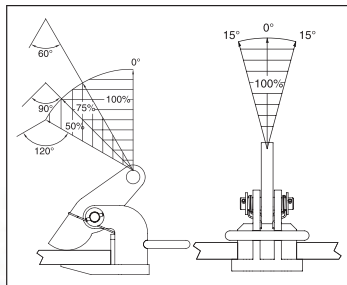
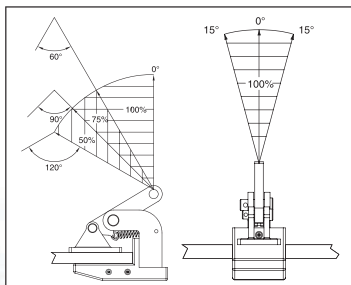



# Horizontal Clamps



**IPH10E**

The IPH10E / IPH10JE horizontal lifting clamps are for use in the lifting and transfer in horizontal position of non-sagging materials or of bundles of non-sagging material. These clamps must be used in pairs or more.

## For Horizontal Lifting and Transfer

- Available in capacities of .75 thru 25 metric tons.
- Wide variety of jaw openings available: 0 to 120mm.
- Welded alloy steel body for strength and smaller size. Forged alloy, components where required.
- Equipped with handle for easy placement.
- Individually Proof Tested to 2 times the Working Load Limit with certification.
- Company name (CrosbyIP), logo, Working Load Limit and jaw opening permanently stamped on body.
- Each product is individually serialized, with the serial number and Proof Load test date stamped on body. User manual with test certificate is included with each clamp.
- Maintenance replacement parts are available.
- Manufactured by an ISO 9001 facility.
- All sizes are **RFID EQUIPPED**.

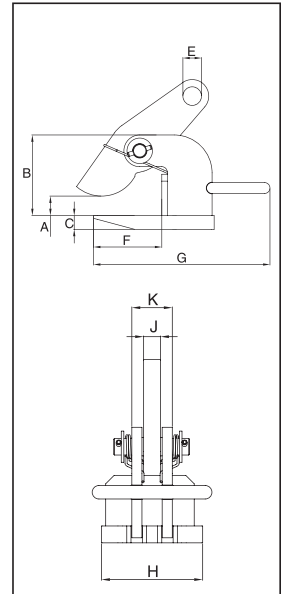

## Model IPH10E: Jaw opening range 0 to 60mm

Model	Working Load Limit (Per Pair) (t)*	IPH10E Stock No.	Weight Each (kg)	Dimensions (mm)									
				Jaw A	B	C	E	F	G	H	J	K	
IPH10E	2	2703542	5.50	0 - 60	117	16	22	109	256	110	20	40	
IPH10E	3	2703543	7.50	0 - 60	117	20	26	109	266	120	20	48	
IPH10E	4.5	2703544	10.5	0 - 60	132	25	30	104	280	130	20	48	
IPH10E	6	2703545	13.0	0 - 60	143	25	36	123	320	130	20	48	
IPH10E	9	2703546	18.5	0 - 60	157	30	43	133	330	140	25	62	
IPH10E	12	2703547	21.5	0 - 60	172	30	47	141	353	150	25	62	
**IPH10Z	25	2705119	39.0	0 - 60	169	40	47	164	300	220	32	88	

\* Design Factor based on EN 13155 and ASME B30.20. \*\*Without handle.

## Model IPH10JE: Jaw opening range 60 to 120mm

Model	Working Load Limit (Per Pair) (t)*	IPH10JE Stock No.	Weight Each (kg)	Dimensions (mm)									
				Jaw A	B	C	E	F	G	H	J	K	L
IPH10JE	3	2703553	9.00	60-120	177	20	26	109	266	120	20	48	11
IPH10JE	4.5	2703554	12.0	60-120	192	25	30	104	280	130	20	48	12
IPH10JE	6	2703555	15.0	60-120	203	25	36	123	320	130	20	48	14
IPH10JE	9	2703556	20.5	60-120	217	30	43	133	330	140	25	62	16
IPH10JE	12	2703557	24.0	60-120	232	30	47	141	353	150	25	62	17

\* Design Factor based on EN 13155 and ASME B30.20.

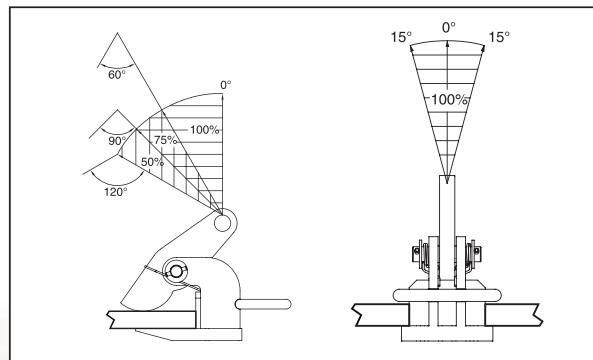



**IPHOZ**

The IPHOZ horizontal lifting clamp is to be used for lifting and transferring, in the horizontal position, of thin sheet and other materials that will sag or bend when lifted. These clamps must be used in pairs or more.

### For Horizontal Lifting and Transfer

- Available in capacities of .75 thru 25 metric tons.
- Wide variety of jaw openings available: 0 to 60mm.
- Welded alloy steel body for strength and smaller size. Forged alloy components, where required.
- Equipped with handle for easy placement.
- Individually Proof Tested to 2 times the Working Load Limit with certification.
- Company name (CrosbyIP), logo, Working Load Limit and jaw opening permanently stamped on body.
- Each product is individually serialized, with the serial number and Proof Load test date stamped on body. User manual with test certificate is included with each clamp.
- Maintenance replacement parts are available.
- Manufactured by a ISO 9001 facility.
- All sizes are **RFID EQUIPPED**.

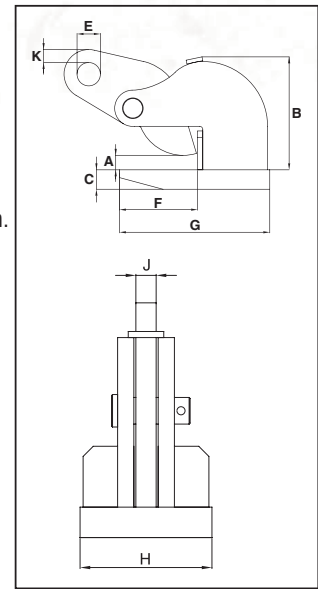

**Load Rated**

### Model IPHOZ: Jaw opening range 0 to 60mm

Model	Working Load Limit (Per Pair) (t)*	IPHOZ Stock No.	Weight Each (kg)	Dimensions (mm)								
				Jaw A	B	C	E	F	G	H	J	K
IPHOZ	0.75	2705401	3.0	0 - 30	94	16	16	70	118	81	12	12
IPHOZ	1.5	2705402	5.5	0 - 45	133	16	22	125	192	100	16	12
IPHOZ	3	2705403	8.0	0 - 45	137	20	26	125	200	120	20	10
IPHOZ	4.5	2705404	8.5	0 - 45	138	25	30	126	220	120	20	10
<b>With larger jaw opening</b>												
IPHOZ	6	2705405	15.5	0 - 60	171	30	36	135	235	130	20	20
IPHOZ	9	2705406	20.5	0 - 60	211	30	43	166	276	160	25	20
IPHOZ	12	2705407	38.0	0 - 60	217	40	47	168	294	190	25	19
IPHOZ	15	2705408	83.8	0 - 60	8.66	1.57	1.85	7.20	12.48	9.84	.98	.87

\* Design Factor based on EN 13155 and ASME B30.20.

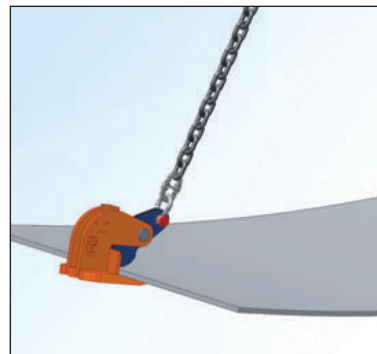
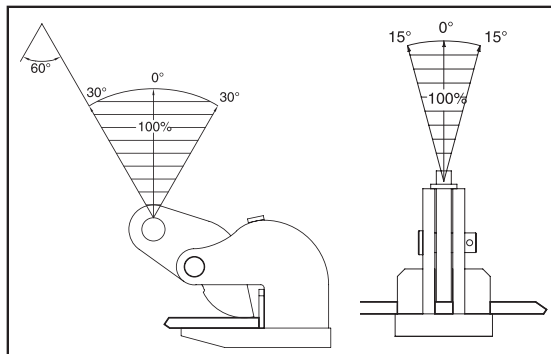

# Horizontal Clamps



## IPBC

The IPBC horizontal lifting clamps have a pretension feature that allows the user to attach the clamps to the material for horizontal lifting and transfer of sagging and non-sagging material. These clamps may also be used to handle material that will be used in shears, bending and rolling machines or other fabrication equipment. May also be used for turning beams from the "H" into the "I" position.

## For Horizontal Transfer - with Pretension System

- Available in capacities of 1 thru 4.5 metric tons.
- Jaw openings available: 0 to 40mm.
- Welded alloy steel body for strength and smaller size. Forged alloy components, where required.
- Individually Proof Tested to 2 times the Working Load Limit with certpermanently stamped on body.
- Each product is individually serialized, with the serial number and Proof Load test date stamped on body. User manual with test certificate is included with each clamp.
- Maintenance replacement parts are available.
- Manufactured by a ISO 9001 facility.
- All sizes are **RFID EQUIPPED**.



## IPHGUZ

The IPHGZ, IPHGUZ horizontal lifting clamps have a pretension locking feature that allows the user to attach the clamps to the material for horizontal lifting and transfer of sagging and non-sagging material. These clamps may also be used to handle material that will be used in shears, bending and rolling machines or other fabrication equipment. May also be used to move and lift structural shapes such as I-Beams, H-beams etc.



# Load Rated

## Model IPBC

Model	Working Load Limit (t)*	IPBC Stock No.	Weight Each (kg)	Dimensions (mm)								
				Jaw A	B	C	E	F	G	H	J	K
IPBC	1	2700410	3.5	0 - 20	132	52	26	75	185	36	16	182
IPBC	2	2700411	6.5	0 - 25	152	62	30	82	210	49	20	218
IPBC	3	2700412	8.5	0 - 25	157	66	30	82	210	57	20	225

\* Design Factor based on EN 13155 and ASME B30.20.

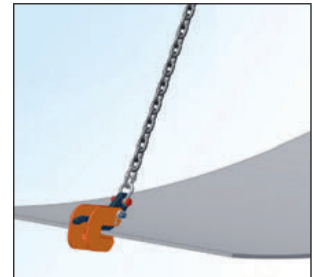
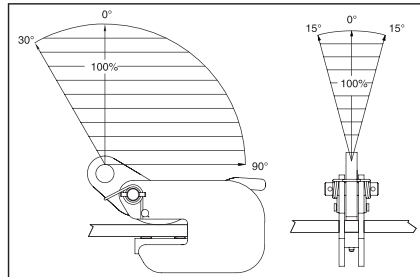
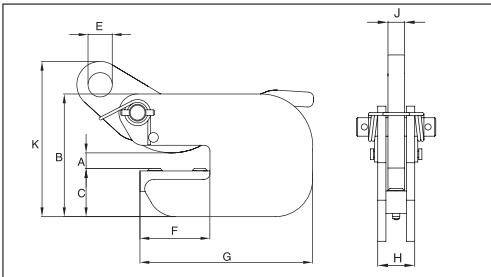

## Model IPHGUZ: Universal Lifting Eye / Model IPHGZ: Fixed Hoisting Eye

Model	Working Load Limit (t)*	Stock No.	Weight Each (kg)	Dimensions (mm)								
				Jaw A	B	C	D	E	F	G	J	K
IPHGUZ	1.5	2705455	9.0	0 - 25	110	232	287	70	139	90	20	16
IPHGUZ	3.0	2705456	19.9	0 - 40	119	253	348	75	175	120	25	20
IPHGUZ	4.5	2705457	30.0	0 - 40	119	301	370	80	175	155	30	44
Fixed Hoisting Eye												
IPHGZ	.75	2705451	4.0	0 - 25	82	148	206	50	99	98	12	22
IPHGZ	1.5	2705452	7.3	0 - 25	110	200	250	50	118	90	20	28
IPHGZ	3.0	2705453	12.3	0 - 40	120	227	305	70	148	120	25	32
IPHGZ	4.5	2705454	25.0	0 - 40	120	284	381	70	181	155	30	40

\* Design Factor based on EN 13155 and ASME B30.20.

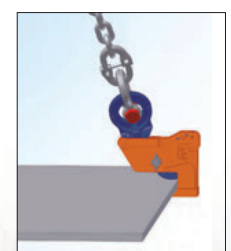
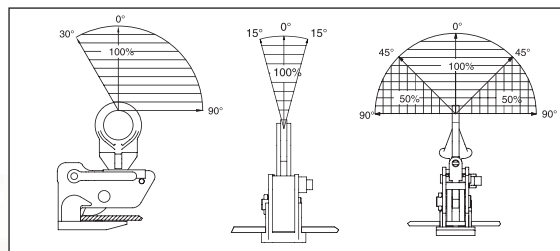
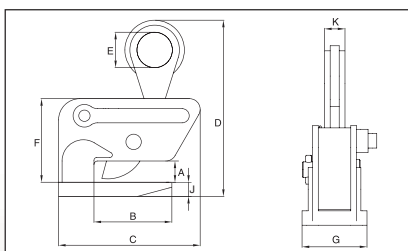





IPPE

The IPPE is suitable for lifting and transfer ring bundles of non-sagging steel plates in horizontal position. The jaw opening can be easily adjusted. Raising the handle opens the clamp. This facilitates the easy and quick placing or removing of the clamp.

**For lifting and transfer ring bundles of plates**

- Available in capacities of 3 thru 12 metric tons.
- Wide variety of jaw openings available: 0 to 420mm.
- Welded alloy steel body for strength and smaller size. Forged alloy components, where required.
- Individually Proof Tested to 2 times the Working Load Limit with certification.
- Company name (CrosbyIP), logo, Working Load Limit and jaw opening permanently stamped on body.
- Each product is individually serialized, with the serial number and Proof Load test date stamped on body. User manual with test certificate is included with each clamp.
- Manufactured by a ISO 9001 facility.
- All sizes are **RFID EQUIPPED**.

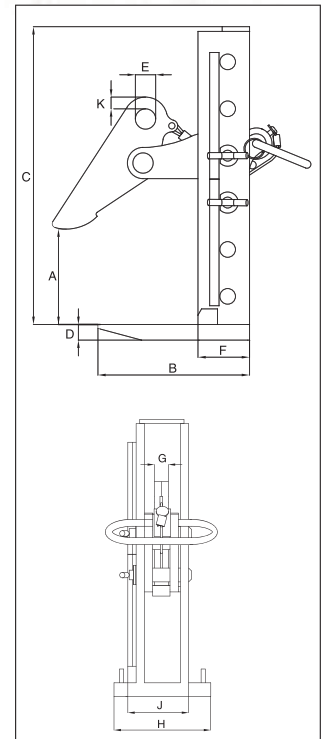

**Model IPPE**

Model	IPPE Stock No.	Working Load Limit (Per Pair) (t)*	Weight Each (kg)	Dimensions (mm)									
				Jaw A	B	C	D	E	F	G	H	J	K
3 IPPEB	2700501	3.0	10.5	0-180	194	256	20	26	66	20	140	76	15
3 IPPED	2700502	3.0	13.0	0-300	194	376	20	26	66	20	140	76	15
3 IPPEH	2700503	3.0	14.0	0-420	194	496	20	26	66	20	140	76	15
6 IPPEH	2700506	6.0	23.0	0-420	227	516	25	30	102	20	160	76	13
9 IPPEH	2700509	9.0	31.0	0-420	270	566	25	34	122	20	190	76	21
12 IPPEH	2700512	12.0	52.0	0-420	292	588	30	40	133	25	200	97	18

\* Design Factor based on EN 13155 and ASME B30.20.

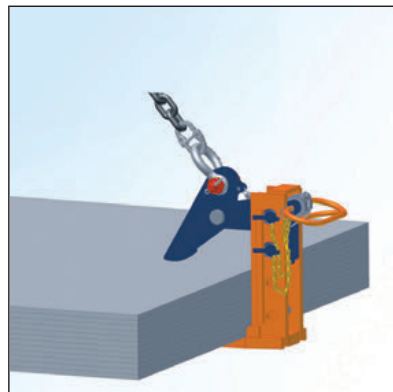
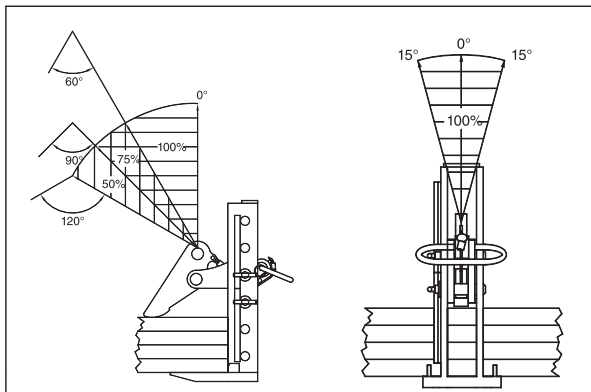

# Beam Clamps



## IPBKZ

The IPBKZ beam clamp is used for lifting, transfer ring and stacking H-Beams. An over-center hoist eye allows for the beam flange to remain vertical. This series of clamps can be used in vertical and horizontal moving, transfer ring and stacking of different types of structural designs, such as H-Beams, angles, etc, depending on the application desired.

## For the Transfer and Stacking of Steel Beams

- Available in capacities of .75 thru 3.75 metric tons.
- Wide variety of jaw openings available: 0 to 28mm.
- Welded alloy steel body for strength and smaller size. Forged alloy components, where required.
- Individually Proof Tested to 2 times the Working Load Limit with certification.
- Company name (Crosby/IP), logo, Working Load Limit and jaw opening permanently stamped on body.
- Each product is individually serialized, with the serial number and Proof Load test date stamped on body. User manual with test certificate is included with each clamp.
- Optional IP-5000 Stinger assembly available (see page 428). Allows for easy connection between the clamp and hoist hook.
- Minimum WLL of 10% of Maximum WLL.
- Maintenance replacement parts are available.
- Manufactured by a ISO 9001 facility.
- All sizes are **RFID EQUIPPED**.



## IPVUZ

The IPVZ / IPVUZ beam clamp is used for vertical lift and transfer of angle iron and other loads that have only a small gripping area for the clamp ("U" has universal hoisting eye).

This series of clamps can be used in vertical and horizontal moving, transfer ring and stacking of different types of structural designs, such as H-beams, angles, etc, depending on the application desired.



## Model IPBKZ

Model	Working Load Limit (t)*	IPBKZ Stock No.	Weight Each (kg)	Dimensions (mm)								
				Jaw A	B	C	D	E	F	G	H	J
IPBKZ	.75	2705780	3.5	5 - 15	43	132	192	45	113	47	38	10
IPBKZ	1.5	2705781	7.0	5 - 25	62	210	300	70	163	61	50	16
IPBKZ	3.75	2705782	15.5	5 - 28	75	260	415	100	202	78	52	20

\* Design Factor based on EN 13155 and ASME B30.20.

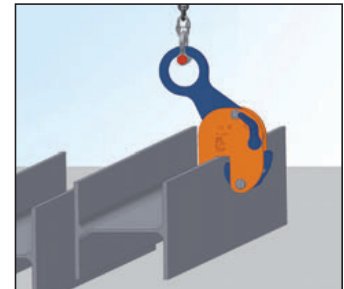
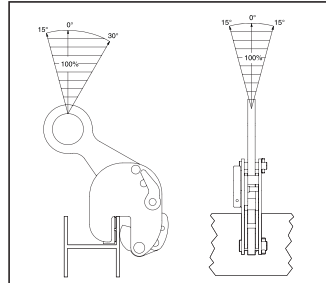
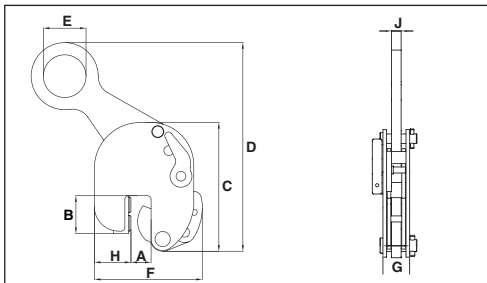

## Model IPVUZ: Universal Hoisting Eye / Model IPVZ: Fixed Hoisting Eye

Model	Working Load Limit (t)*	Stock No.	Weight Each (kg)	Dimensions (mm)								
				Jaw A	B	C	D	E	F	G	H	K
IPVUZ	0.75	2705146	2.3	0 - 15	26	128	238	30	128	41	37	10
IPVUZ	1.5	2705147	8.9	0 - 20	60	200	378	70	200	61	72	16
<b>Fixed Hoisting Eye</b>												
IPVZ	0.75	2705096	2.1	0 - 15	26	128	207	30	115	41	30	10
IPVZ	1.5	2705097	6.2	0 - 20	60	200	339	70	180	52	50	16

\* Design Factor based on EN 13155 and ASME B30.20.

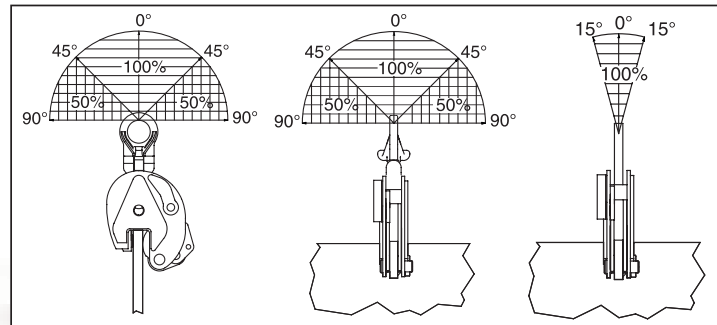
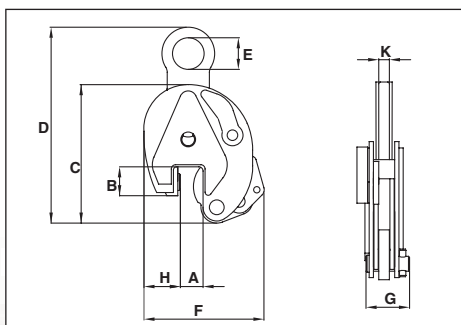



**IPBHZ**

The IPBHZ beam clamp is used for horizontal lifting and transfer ring of steel beams. The base is slotted to allow the clamps to be used from end of beams as well as from the flange. This series of clamps can be used in vertical and horizontal moving, transfer ring and stacking of different types of structural designs, such as I-Beams, H-beams, angles, etc, depending on the application desired.

**For the Lifting and Transfer of Steel Beams**

- Available in capacities of .75 thru 12 metric tons.
- Wide variety of jaw openings available: 0 to 50mm.
- Welded alloy steel body for strength and smaller size. Forged alloy components, where required.
- Individually Proof Tested to 2 times the Working Load Limit with certification.
- Company name (CrosbyIP), logo, Working Load Limit and jaw opening permanently stamped on body.
- Each product is individually serialized, with the serial number and Proof Load date stamped on body. User manual with test certificate is included with each clamp.
- Optional IP-5000 Stinger assembly available (see page 428). Allows for easy connection between the clamp and hoist hook.
- Minimum WLL of 10% of Maximum WLL.
- Maintenance replacement parts are available.
- Manufactured by a ISO 9001 facility.
- All sizes are **RFID EQUIPPED**.



**IPBSNZ**

The IPBSNZ beam clamp is used for lifting, transfer ring and stacking. Offset hoisting eye allows for level lifts of I-Beams. Also for lifting fabrications and ship sections. This series of clamps can be used in vertical and horizontal moving, transfer ring and stacking of different types of structural designs, such as I-Beams, depending on the application desired.



**Load Rated**

**Model IPBHZ**

Model	Working Load Limit (t)*	IPBHZ Stock No.	Weight Each (kg)	Dimensions (mm)								
				Jaw A	B	C	D	E	F	G	J	K
IPBHZ	.75	2705461	3.0	0 - 25	40	148	220	50	130	69	33	22
IPBHZ	1.5	2705462	6.0	0 - 25	60	200	255	50	153	73	35	28
IPBHZ	3	2705463	10.5	0 - 40	80	227	325	70	188	112	38	32
IPBHZ	4.5	2705464	25.0	0 - 40	112	284	413	70	251	116	80	40
IPBHZ	12	2705467	42.0	0 - 40	125	466	490	90	317	90	90	47

\* Design Factor based on EN 13155 and ASME B30.20.

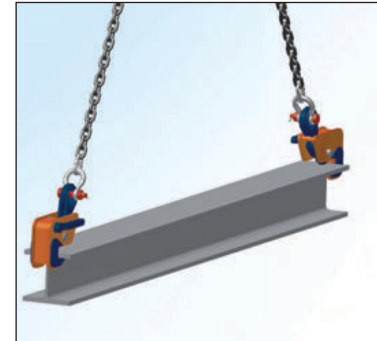
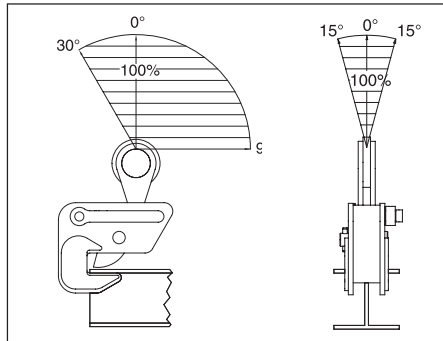
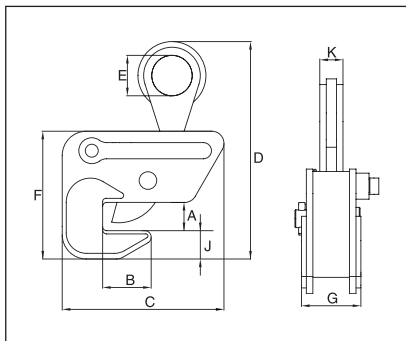

**Model IPBSNZ**

Model	Working Load Limit (t)*	IPBSNZ Stock No.	Weight Each (kg)	Dimensions (mm)									
				Jaw A	B	C	D	E	F	G	H	J	K
IPBSNZ	1.5	2705925	14.0	0 - 32	100 - 270	304	480	70	319	47	16	165	148
IPBSNZ	3	2705926	22.0	0 - 40	100 - 330	352	494	75	408	56	20	207	182
IPBSNZ	4.5	2705927	30.5	0 - 50	100 - 360	420	630	75	457	56	20	250	188

\* Design Factor based on EN 13155 and ASME B30.20.

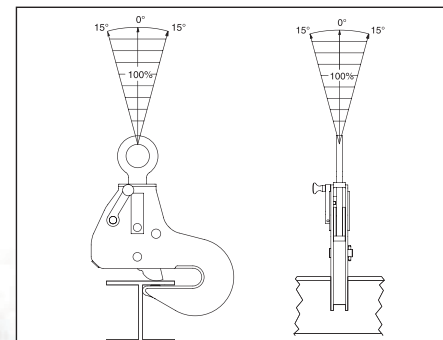
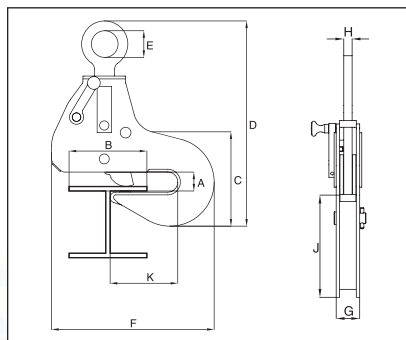



# Beam Clamps



**IPTK**  
This IPTK series beam clamp is suitable for use as a temporary tackle eye for a beam.

## For transfer ring steel beams and attaching tackle eye

- Available in capacities of 2 thru 25 metric tons.
- Wide variety of jaw openings available: 75 to 1020mm.
- Welded alloy steel body for strength and smaller size. Forged alloy components, where required.
- Individually Proof Tested to 2 times the Working Load Limit with certification.
- Company name (CrosbyIP), logo, Working Load Limit and jaw opening permanently stamped on body.
- Each product is individually serialized, with the serial number and Proof Load test date stamped on body. User manual with test certificate is included with each clamp.
- Maintenance replacement parts are available.
- Manufactured by a ISO 9001 facility.
- All sizes are RFID EQUIPPED.

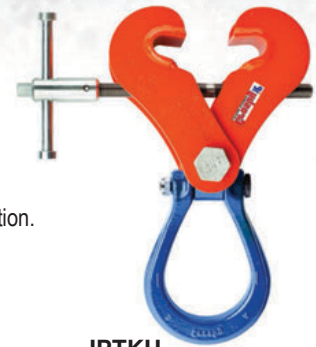

**IPTKU**  
This IPTKU series beam clamp has an improved hinged hoisting eye that increases the loading angles and an optional new "Double Locking Device".

- Model IPTK: With Hoisting Eye
- Model IPTKW: Without Hoisting Eye
- Model IPTKU: With Hinged Hoisting Eye
- Model IPTKUD: With Double Locking Device



**IPTKW**  
This IPTKW series beam clamp is suitable for use as a temporary tackle eye for a beam.

Model	Working Load Limit (t)*	Stock No.	Weight Each (kg)	Dimensions (mm)							
				Jaw A	C	D	E	F	H	J	K
IPTK	2	2700996	6.0	75 - 190	A + 80	125	75	-	25	-	20
IPTK	3	2700997	6.5	75 - 190	A + 80	125	75	-	25	-	20
IPTK	4	2700998	8.5	150 - 280	A + 100	125	75	-	35	-	20
IPTK	5	2700994	11.0	120 - 350	A + 195	125	75	-	40	-	20
IPTK	10	2700970	31.0	300 - 500	A + 300	171	74	-	40	-	30
IPTK	25	2702999	225	450 - 1020	A + 220	500	125	-	76	-	45
<b>Without Hoisting Eye</b>											
IPTKW	2	2700966	4.0	75 - 190	A + 80	125	-	28	25	-	-
IPTKW	3	2700967	4.5	75 - 190	A + 80	125	-	28	25	-	-
IPTKW	4	2700968	6.3	150 - 280	A + 100	125	-	33	35	-	-
IPTKW	5	2700969	8.8	120 - 350	A + 195	125	-	33	40	-	-
<b>With Improved Hinged Hoisting Eye</b>											
IPTKU	2	2707996	5.8	75 - 190	A + 100	121	76	-	22	99	19
IPTKU	3	2707997	6.5	75 - 190	A + 100	121	89	-	22	122	22
IPTKU	4	2707998	9.9	120 - 280	A + 150	140	89	-	40	122	22
IPTKU	5	2707994	12.0	120 - 350	A + 175	140	89	-	40	122	22
IPTKU	10	2707970	38.0	200 - 460	A + 300	200	105	-	60	152	26
<b>With Optional Double Locking Device</b>											
IPTKU/D	2	2709996	5.8	75 - 190	A + 100	165	89	-	22	99	19
IPTKU/D	3	2709993	6.5	75 - 190	A + 100	165	89	-	22	122	22
IPTKU/D	4	2709995	9.9	120 - 280	A + 150	185	89	-	40	122	22
IPTKU/D	5	2709994	12.0	120 - 350	A + 175	185	89	-	40	122	22
IPTKU/D	10	2709970	38.0	200 - 460	A + 300	250	105	-	60	152	26

\* Design Factor based on EN 13155 and ASME B30.20.

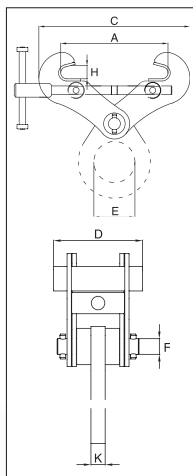

IPTK

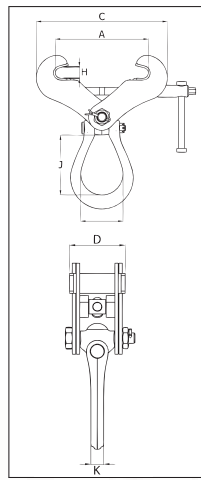

IPTKU

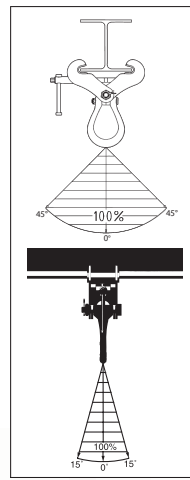

IPTKU

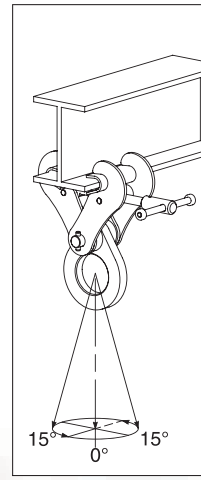

IPTKW

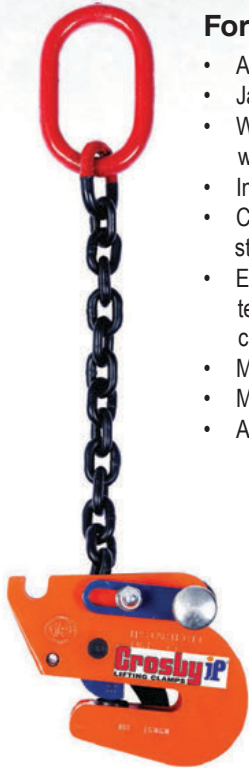

**For lifting and transfer ring steel beams**

- Available in capacities of 1.5 and 2.5 metric tons.
- Jaw openings available: 6 to 20mm.
- Welded alloy steel body for strength and smaller size. Forged alloy components, where required.
- Individually Proof Tested to 2 times the Working Load Limit with certification.
- Company name (CrosbyIP), logo, Working Load Limit and jaw opening permanently stamped on body.
- Each product is individually serialized, with the serial number and Proof Load test date stamped on body. User manual with test certificate is included with each clamp.
- Maintenance replacement parts are available.
- Manufactured by an ISO 9001 facility.
- All sizes are **RFID EQUIPPED**.

**IPSTARTEC11**

The IPSTARTEC11 beam clamp has been specially developed for lifting with the body in vertical position, controlled tilting, transportation and stacking of steel "H" and "I" profiles. By placing the chain guide in the appropriate position, it is easy to switch from lifting to tilting and back again, which shifts the center of gravity.

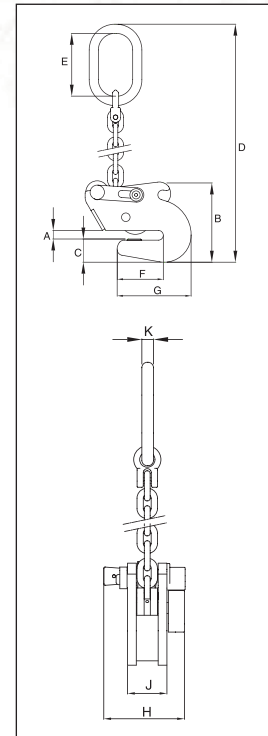

Load Rated

Model IPSTARTEC11

Model	Working Load Limit (t)*	IPSTARTEC11 Stock No.	Weight Each (kg)	Dimensions (mm)									
				Jaw A	B	C	D	E	F	G	H	J	K
IPSTARTEC11	1.5	2701812	6.6	6 - 12	140	39	575	110	81	129	54	126	16
IPSTARTEC11	2.5	2701822	14.5	6 - 20	210	55	725	135	115	182	74	140	18

\* Design Factor based on EN 13155 and ASME B30.20.

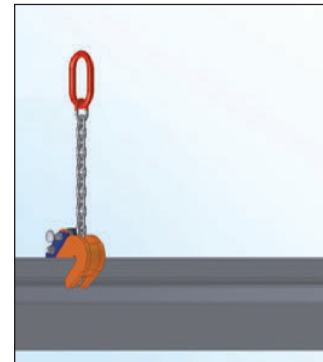
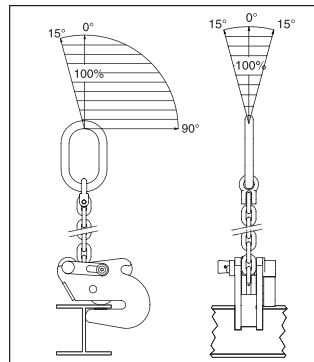

# Drum Clamps



## IPDV

The IPDV drum clamp is for vertical lift and transfer. Allows drum to remain in an upright position during the lift and transfer using one clamp.

## Designed to lift, move and transfer 50-55 gallon drums with steel tops

- Available in capacity of .5 metric tons.
- Jaw openings available: IPDV - 300mm IPVK - 17mm.
- Welded alloy steel body for strength and smaller size. Forged alloy components, where required.
- Individually Proof Tested to 2 times the Working Load Limit with certification.
- Company name (CrosbyIP), logo, Working Load Limit and jaw opening permanently stamped on body.
- Each product is individually serialized, with the serial number and Proof Load test date stamped on body. User manual with test certificate is included with each clamp.
- Maintenance replacement parts are available.
- Manufactured by an ISO 9001 facility.
- IPDV is RFID EQUIPPED.

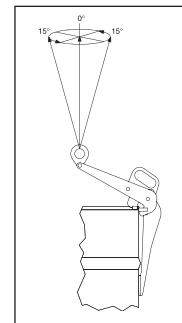
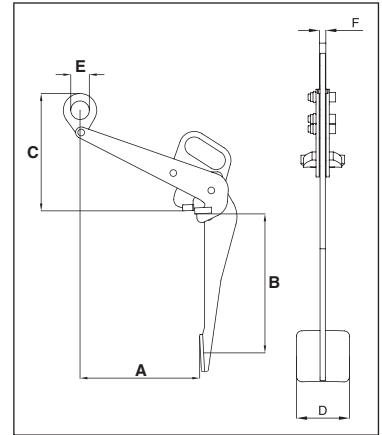

## Model IPDV

Model	Working Load Limit (t)*	IPDV Stock No.	Weight Each (kg)	Dimensions (mm)					
				Jaw A	B	C	D	E	F
IPDV	.5	2700118	7.1	300	375	290	150	50	12

\* Design Factor based on EN 13155 and ASME B30.20.



## IPVK

The IPVK drum clamp is for vertical lift and transfer. Automatically locks on drum, and can be used alone or in pairs.

## Model IPVK

Model	Working Load Limit (t)*	IPVK Stock No.	Weight Each (kg)	Dimensions (mm)						
				Jaw A	B	C	D	E	G	K
IPVK	.5	2700116	1.6	17	26	26	132	29	51	11

\* Design Factor based on EN 13155 and ASME B30.20.

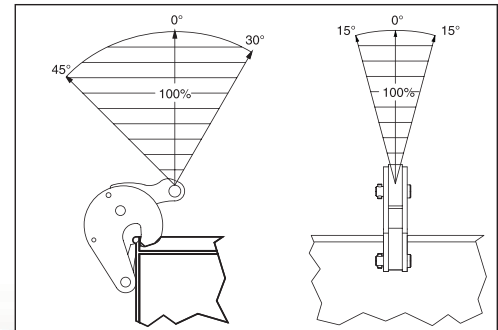
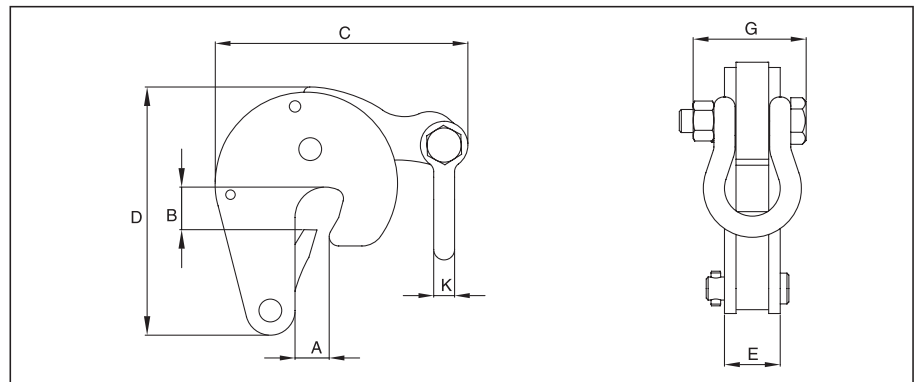

**CROSBY® LIFTING CLAMPS**





IPCC

The IPCC is suitable for the vertical lifting and transfer of concrete pipe sections and wells. Very easy application and removal of the clamp thanks to the built-in carrying-grips. Normally used in combination with 7mm chain (not supplied). These clamps must be used in pairs or more.

**For lifting and transfer ring of concrete pipe sections and wells**

- Available in capacity of 1 metric tons.
- Jaw opening available: 40 - 140mm.
- Welded alloy steel body for strength and smaller size. Forged alloy components, where required.
- Individually Proof Tested to 2 times the Working Load Limit with certification.
- Company name (CrosbyIP), logo, Working Load Limit and jaw opening permanently stamped on body.
- Each product is individually serialized, with the serial number and Proof Load test date stamped on body. User manual with test certificate is included with each clamp.
- Maintenance and replacement parts are available.
- Manufactured by an ISO 9001 facility.
- All sizes are **RFID EQUIPPED**.

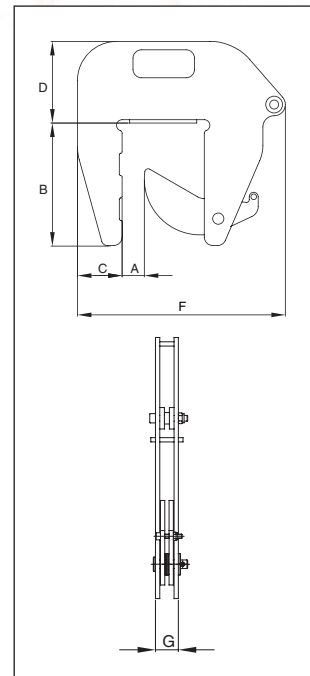

Load Rated

**Model IPCC**

Model	IPCC Stock No.	Working Load Limit Per Pair (t)*	Weight Each (kg)	Dimensions (mm)									
				Jaw A	B	C	D	E	F	G	H	J	K
IPCC	2700037	1,0	9.2	40-140	225	80	146	-	372	37	-	-	-

\* Design Factor based on EN 13155 and ASME B30.20.

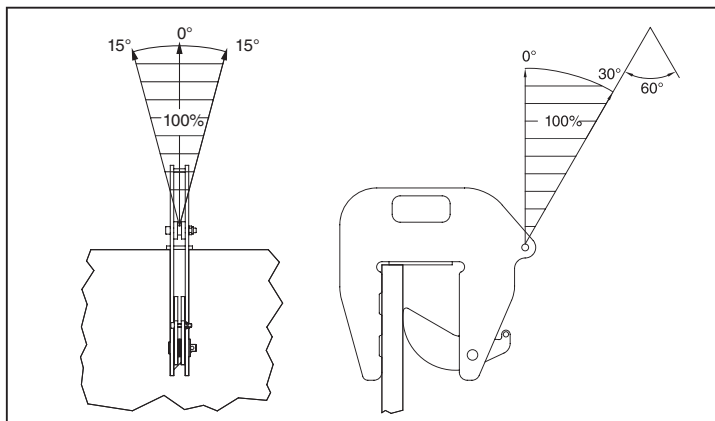

# Shipbuilding Clamps: Bulb Profiles



**IPBUZ**

The IPBUZ shipbuilding clamps are used for lifting, transfer ring and placing bulb profiles onto ship's hulls perpendicularly. These clamps are fitted with a locking device for both open and closed positions, which ensures complete reliability. They are to be used exclusively for bulb profiles (not for plates).

## For lifting, transfer ring and placing Bulb Profiles onto Ships' Hulls Perpendicularly

- Available in capacities of .75 thru 3.75 metric tons.
- Jaw openings available: HP 120mm to HP 430mm.
- Welded alloy steel body for strength and smaller size. Forged alloy components, where required.
- Individually Proof Tested to 2 times the Working Load Limit with certification.
- Company name (CrosbyIP), logo, Working Load Limit and jaw opening permanently stamped on body.
- Each product is individually serialized, with the serial number and Proof Load test date stamped on body. User manual with test certificate is included with each clamp.
- Optional IP-5000 Stinger assembly available (see page 428). Allows for easy connection between the clamp and hoist hook.
- Maintenance replacement parts are available.
- Manufactured by a ISO 9001 facility.
- All sizes are **RFID EQUIPPED**.

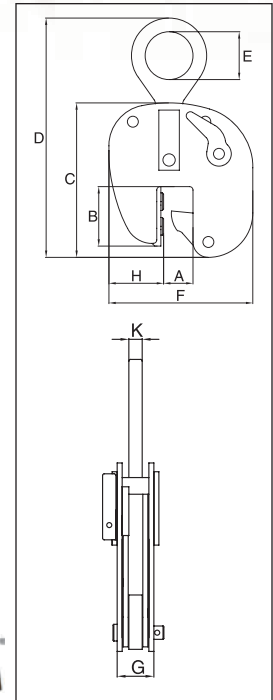

### Model IPBUUZ: with Universal Hoisting Eye Model IPBUZ: with Fixed Hoisting Eye

Model	Working Load Limit (t)*	Stock No.	Weight Each (kg)	Dimensions (mm)								
				Profile A †	B	C	D	E	F	G	H	K
IPBUUZ	.75	2705601	8.5	HP 120-200	85	226	390	70	210	61	70	16
<b>With fixed hoisting eye</b>												
IPBUZ	.75	2705600	7.0	HP 120-200	85	226	390	70	210	61	70	16
IPBUZ	1.5	2705701	15.0	HP 220-430	196	397	568	70	256	69	48	16
IPBUZ	3.75	2705702	28.5	HP 220-430	238	438	565	80	355	64	100	20

\* Design Factor based on EN 13155 and ASME B30.20. † Profile A is the type of Holland Bulb (HP) style and size material.

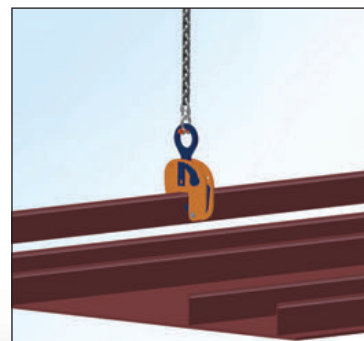
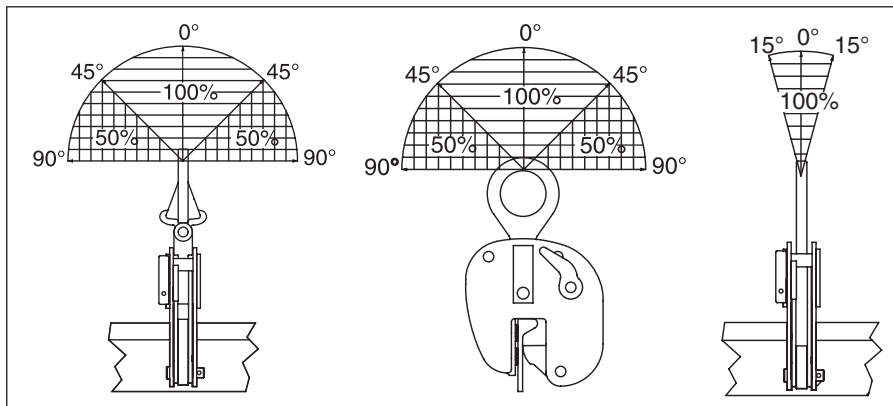

**CROSBY® LIFTING CLAMPS**



IP5BUUZ

The IP5BU(U)Z shipbuilding clamps are used for the lifting, transfer and placing of complete shipsections. These clamps are fitted with a locking device for both open and closed positions, which ensures complete reliability. They are to be used exclusively for bulb profiles (not for plates).

**For lifting, transfer ring and placing complete shipsections**

- Available in capacities of 4.5 thru 22.50 metric tons.
- Wide variety of jaw openings available: HP 100mm to HP 430mm.
- Welded alloy steel body for strength and smaller size. Forged alloy components, where required.
- Individually Proof Tested to 2 times the Working Load Limit with certification.
- Company name (Crosby/IP), logo, Working Load Limit and jaw opening permanently stamped on body.
- Each product is individually serialized, with the serial number and Proof Load test date stamped on body. User manual with test certificate is included with each clamp.
- Optional IP-5000 Stinger assembly available (see page 428). Allows for easy connection between the clamp and hoist hook.
- Maintenance replacement parts are available.
- Manufactured by a ISO 9001 facility.
- All sizes are **RFID EQUIPPED**.

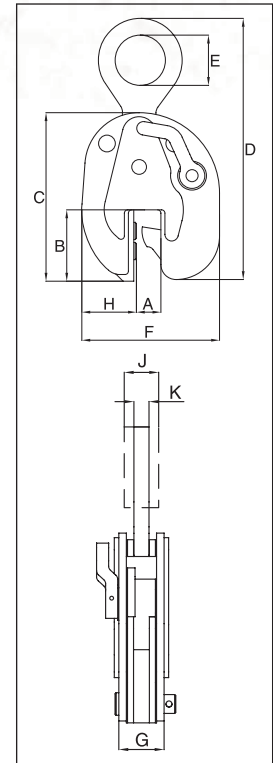

**Model IP5BUUZ and IP5BUSUZ: With Universal Hoisting Eye**  
**Model IP5BUZ and IP5BUSZ: With Fixed Hoisting Eye**

Model	Working Load Limit (t)*	Stock No.	Weight Each (kg)	Dimensions (mm)									
				Profile A†	B	C	D	E	F	G	H	J	K
IP5BUUZ	4.5	2705771	15.5	HP 100-160	107	252	450	75	206	96	82	36	20
IP5BUSUZ	4.5	2705772	38.0	HP 180-430	227	428	635	75	377	95	128	-	20
IP5BUUZ	9	2705773	43.0	HP 100-160	105	274	491	80	248	123	104	44	20
IP5BUSUZ	9	2705774	59.0	HP 180-430	227	478	718	80	425	118	155	44	25
<b>With fixed hoisting eye</b>													
IP5BUZ	4.5	2705721	13.5	HP 100-160	107	252	382	75	206	96	82	-	20
IP5BUSZ	4.5	2705722	35.8	HP 180-430	227	428	592	75	377	95	128	-	20
IP5BUZ	9	2705723	23.0	HP 100-160	105	274	461	80	248	123	104	-	30
IP5BUSZ	9	2705724	68.0	HP 180-430	227	478	672	80	425	118	155	45	25
IP5BUSZ	15	2705728	64.0	HP 180-430	226	485	690	88	401	100	135	49	25
IP5BUSZ	22.5	2705730	100	HP 180-430	224	543	740	90	470	116	185	-	30

\* Design Factor based on EN 13155 and ASME B30.20. † Profile A is the type of Holland Bulb (HP) style and size material.

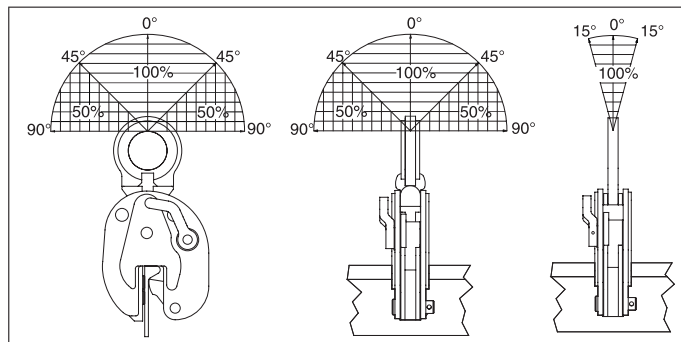



# Shipbuilding Clamps: Bulb Profiles



## IPBTO10

The IPBTO10 shipbuilding clamp is used as a temporary tackle eye in spaces which have been reinforced with HP (bulb) profiles such as engine rooms and shipsections. This clamp is fitted with a screwed spindle for easy attachment of the clamp. The moment a load is applied, the clamp is automatically fixed.

**For use as a temporary tackle eye in spaces that have been reinforced with HP (bulb) profiles such as engine rooms and shipsections.**

- Available in capacities of 1.5 thru 6 metric tons.
- Wide variety of jaw openings available: HP 160mm to HP 430mm.
- Welded alloy steel body for strength and smaller size. Forged alloy components, where required.
- Individually Proof Tested to 2 times the Working Load Limit with certification.
- Company name (CrosbyIP), logo, Working Load Limit and jaw opening permanently stamped on body.
- Each product is individually serialized, with the serial number and Proof Load test date stamped on body. User manual with test certificate is included with each clamp.
- Maintenance replacement parts are available.
- Manufactured by an ISO 9001 facility.

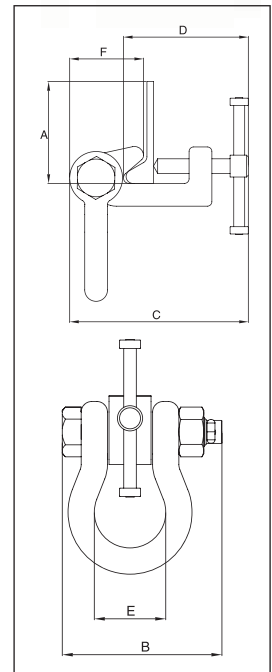

## Model IPBTO10

Model	Working Load Limit (t)*	IPBTO10 Stock No.	Weight Each (kg)	Dimensions (mm)					
				Profile A †	B	C	D	E	F
IPBTO10	1.5	2700980	4.3	HP 160-240	137	188-209	129-150	68	81
IPBTO10	3	2700986	6.0	HP 240-320	137	188-217	145-174	68	78
IPBTO10	6	2700991	13.0	HP 300-430	185	255-297	195-236	98	102

\* Design Factor based on EN 13155 and ASME B30.20. † Profile A is the type of Holland Bulb (HP) style and size material.

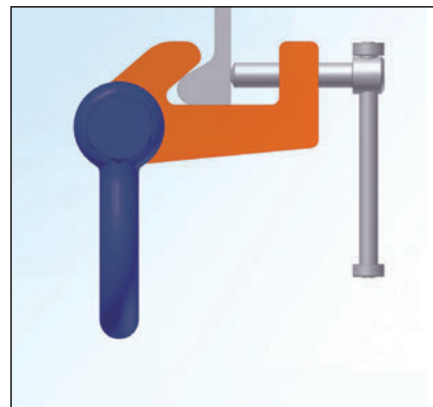
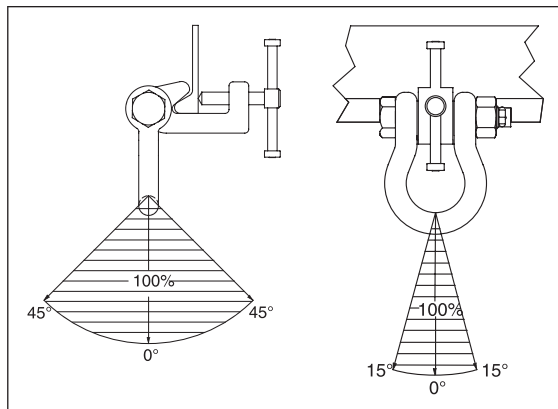



**IPSC10**

The IPSC10 screw style clamp is for positioning, pulling and turning plates or fabrications.

**Suitable for use in positioning & turning steel plates and sections.  
Not to be used as a lifting clamp.**

- Available in capacities of 1.5 and 3 metric tons.
- Jaw openings available: 0 to 60mm.
- Suitable for steel with a surface hardness up to 30 Rc.
- Forged alloy steel body for strength and smaller size. Forged alloy components, where required.
- Individually Proof Tested to 2 times the Working Load Limit with certification.
- Company name (CrosbyIP), logo, Working Load Limit and jaw opening permanently stamped on body.
- Each product is individually serialized, with the serial number and Proof Load test date stamped on body. User manual with test certificate is included with each clamp.
- Maintenance replacement parts are available.
- Manufactured by an ISO 9001 facility.

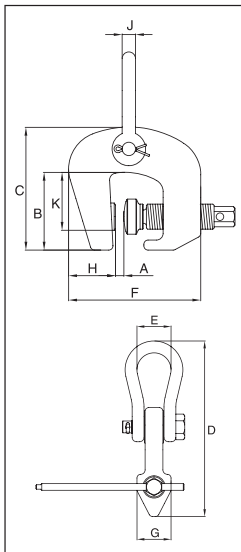

**Model IPSC10**

Model	Working Load Limit (t)*	IPSC Stock No.	Weight Each (kg)	Dimensions (mm)									
				Jaw A	B	C	D	E	F	G	H	J	K
IPSC10	1.5	2703857	4.6	0 - 40	90	143	251	44	156	50	45	16	65
IPSC10	3	2703858	8.4	0 - 60	109	175	310	51	200	62	55	19	83

\* Design Factor based on EN 13155 and ASME B30.20.

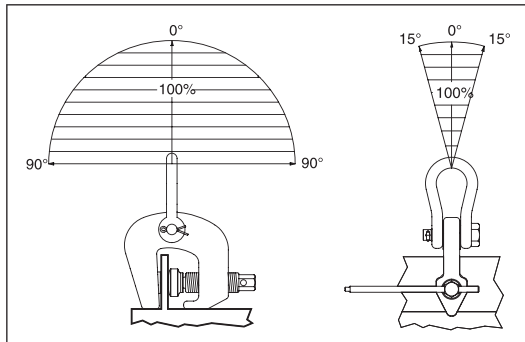

**IP5000**

The IP5000 Stinger Assembly is designed to be used as a connecting link between the clamp and the hoist hook.

**Provides easy attachment of selected Crosby® IP clamp to hoist hook.**

- Available in three sizes for the IP10 and IPU10 with capacities from .5 to 12 metric tons.
- Assembly consists of welded alloy master link, Grade 80 chain and A-1337 Lok-A-Loy for attachment to the clamp hoisting eye.
- Individually Proof Tested to 2.5 times the Working Load Limit of Grade 80 chain with certification.
- Company name or logo and frame number permanently stamped on link.
- Locking system provides for simple assembly - no special tools needed.
- Finish - Red Paint.
- Manufactured by an ISO 9001 facility.



**NOTE: Not Intended to be Used as a Chain Sling.**

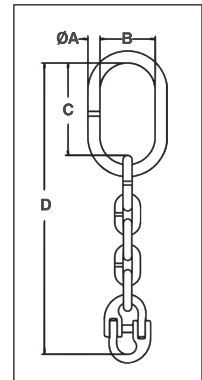

**Model IP5000**

Frame Size	Chain Size		Crosby® IP10 and IPU10 Clamp Sizes (t)*	IP5000 Stock No.	Weight Each (kg)	Dimensions (mm)			
	(in.)	(mm)				A	B	C	D
1	5/16	8	0.5 - 1	2701695	.95	13.0	59.9	100	315
2	1/2	13	2 - 4.5	2701704	3.4	22.1	89.9	144	484
3	7/8	22	6 - 12	2701713	14.7	36.1	140	234	820

\* The working load of the assembly is based on working load limit of the selected clamp. Ultimate load is 5 times the Working Load Limit.



# Crosby<sup>®</sup> CLAMP-CO CLAMPS

## Setting the Standard for Lifting

- Pipe Clamps
- Beam Clamps
- Barrier Grabs
- Granite/Curb Grabs





# Crosby®

## Clamp-Co Adjustable “Padded” PipeGrab

### Crosby CLAMP-CO®

The new Crosby Clamp-Co® Adjustable Pipe Grab provides an excellent means of handling cylindrical objects. Featuring *padded grabs*, the new Grab offers an excellent method of handling any pipe or solid bar, 3.5” to 36” (88.9 mm to 914 mm), especially where damage to material surface is not permitted.

- Capacities: 1,200 lbs. to 20,000 lbs.  
(544 kg to 9,072 kg)
- Each Grab size accommodates several diameters of pipe or solid bar.
- Auto indexing system provides quick connect and disconnect to load (one person - hands free).
- Individually Proof Tested to 2 times the Working Load Limit with certification.
- Designed to handle loads of various types of material, including:
  - Cast Iron / Steel
  - PVC
  - Painted
  - Epoxy Coated
- Finish - Red Paint
- Replacement pads are available.
- Features Crosby shackle as upper connection point.
- Custom sizes are available.
- All sizes are **RFID EQUIPPED.**



### Features Include:

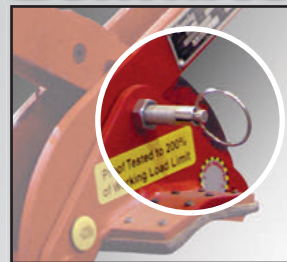

Easy lock and unlock transport lever.

Auto indexing mechanism  
(one person - hands free)



Replaceable Pads

## Crosby®

[www.thecrosbygroup.com](http://www.thecrosbygroup.com)

“When buying Crosby, you’re buying more than product, you’re buying *Quality*”.



CCPA



The new Crosby Clamp-Co<sup>®</sup> Adjustable Pipe Grab provides an excellent means of handling cylindrical objects. Featuring padded grabs, the new Grab offers an excellent method of handling any pipe or solid bar, 3.5" to 36", especially where damage to material surface is not permitted.

- Capacities: 544 kg to 9072 kg.
- Each Grab size accommodates several diameters of pipe or solid bar.
- Auto indexing system provides quick connect and disconnect to load (one person - hands free).
- Individually Proof Tested to 2 times the Working Load Limit with certification.
- Designed to handle loads of various types of material, including:
  - Cast Iron / Steel
  - PVC
  - Painted
  - Epoxy Coated
- Finish - Red Paint
- Replacement pads are available.
- Features Crosby shackle as upper connection point.
- Custom sizes are available.
- All sizes are **RFID EQUIPPED**.



## Padded Pipe Grab

Model No.	CCPA Stock No.	Working Load Limit* (kg)	Weight Each (kg)	Grip Width	Dimensions (mm)					
					A	B	C	D	E	F
PA-5	2736000	544	10.4	Locked Open	343	254	457	165	33.3	12.7
				Min. Pipe 90mm	686	229	203			
				Max. Pipe 140mm	584	229	375			
PA-8	2736009	907	34.0	Locked Open	597	394	705	254	42.9	16.0
				Min. Pipe 141mm	1029	368	356			
				Max. Pipe 224mm	864	375	610			
PA-14	2736018	2041	104	Locked Open	730	610	724	394	38.1	25.4
				Min. Pipe 224mm	1168	572	343			
				Max. Pipe 356mm	864	584	660			
PA-22	2736027	4536	225	Locked Open	1066	914	1079	508	63.5	38.1
				Min. Pipe 356mm	1714	863	482			
				Max. Pipe 559mm	1320	914	1016			
PA-36	2736036	9072	567	Locked Open	1455	1449	1456	762	85.6	38.1
				Min. Pipe 610mm	2337	1330	685			
				Max. Pipe 914mm	1686	1398	1352			

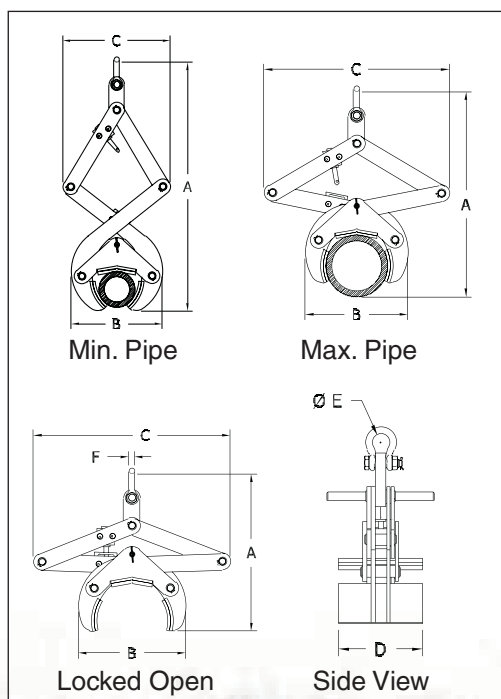

\* Maximum Proof Load is 2 times the Working Load Limit and design factor based on EN13155 and ASME B30.20.

# CROSBY Clamps-Co® Padded Pipe Grab



**CCPG**

**Crosby Clamp-Co® Pipe Grabs provide an excellent means of handling cylindrical objects as long as they meet 1Pipe O.D. and Working Load Limits referenced in the table below.**

- Capacities: 204 kg to 3175 kg.
- Moveable outriggers help stabilize the load.
- No blocking of load required.
- Individually Proof Tested to 2 times the Working Load Limit with certification.
- Designed to handle loads of various types of material, including:
  - Cast Iron
  - Steel
  - PVC
  - C900
  - Yellowmine Ductile Iron
  - Cement Pipe
- Finish - Red Paint.
- Custom sizes are available.
- All sizes are **RFID EQUIPPED**.

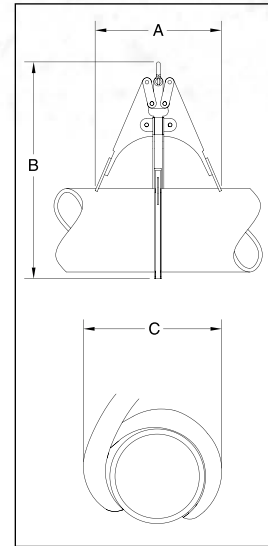

**NOTE:** Pipe grab sizes listed will handle all classes in a category of ASA standard cast iron pipe, C900, Yellowmine, Schedule 40, 80 & 120 PVC or ASA standard steel welded and seamless pipe. Standard, extra strong and double extra all have the same outside diameter.

## For Cast Iron Pipe C-900, C-905, Bluestripe C-906, Certa-Lok PVC Pressure Pipe

Model No.	CCPG- 900 Stock No.	Working Load Limit (kg)*	Pipe O.D. (mm)	Weight Each (kg)	Dimensions (mm)		
					A	B	C
C-3	2730000	204	102	4.54	127	254	152
C-4	2730009	272	122	4.99	203	356	178
C-6	2730018	454	175	6.80	279	432	279
C-8	2730027	635	230	11.3	330	559	356
C-10	2730036	907	282	21.8	381	686	432
C-12	2730045	1134	335	32.7	457	813	508
C-14	2730054	1588	389	47.6	559	965	584
C-16	2730063	1814	442	59.0	610	1067	635
C-18	2730072	2268	495	77.1	660	1143	711
C-20	2730081	2948	549	95.3	711	1270	813
C-24	2730090	3175	655	102	787	1473	889

\* Maximum Proof Load is 2 times the Working Load Limit and design factor based on EN13155 and ASME B30.20.

## For Steel Pipe SDR Class 200, Yellowmine, PVC Schedule 40, 80 and 120

Model No.	CCPG- 200 Stock No.	Working Load Limit (kg)*	Pipe O.D. (mm)	Weight Each (kg)	Dimensions (mm)		
					A	B	C
S-3	2731000	204	88.9	4.54	127	254	152
S-4	2731009	272	114	4.99	203	356	178
S-6	2731018	454	168	6.80	279	432	279
S-8	2731027	635	219	11.3	330	559	356
S-10	2731036	907	273	21.8	381	686	432
S-12	2731045	1134	324	32.7	457	813	508
S-14	2731054	1588	356	47.6	559	965	584
S-16	2731063	1814	406	59.0	610	1067	635
S-18	2731072	2268	457	77.1	660	1143	711
S-20	2731081	2948	508	95.3	711	1270	813
S-24	2731090	3175	610	102	787	1473	889

\* Maximum Proof Load is 2 times the Working Load Limit and design factor based on EN13155 and ASME B30.20.



# CROSBY Clamps-Co<sup>®</sup> Beam Clamps



CCBC

**Crosby Clamp-Co<sup>®</sup> Beam Clamps provide an efficient method for handling wide flange beam sections and plate girders. When lifting, these beam clamps grip the beam at three points, and when properly balanced and safely guided, the beam can be handled even if the clamp is slightly off center lengthwise.**

- Capacities: 4.54 Tons to 31.8 metric tons.
- Eliminates the need for slings, chokers, and spreader bars.
- When applied to load, the tongs automatically open and slide under the flange of the beam.
- Center plate and gripping tongs work together - the heavier the beam, the greater the clamping pressure.
- Model "NS" clamps have a recessed base to accept studs welded to the beam surface.
- Individually Proof Tested to 2 times the Working Load Limit with certification.
- Finish - Red Paint.
- All sizes are **RFID EQUIPPED**.



**NOTE:** Control the beam at all times. Beams should be gripped as near the center as possible. Snubbing lines at each end must be used to control excessive twisting or swinging, and to guide the beam to its proper place. Each lifting situation may have a specific demand which should be addressed before lifting.

## Beam Clamps

Model No.	CCBC-500 Stock No.	Working Load Limit (t)*	Flange Grip Range (mm)		Weight Each (kg)	Dimensions (mm)									
			Width	Thickness		A	B	C	D	E	F	G	H	J	
F-5	2732000	4.54	102 - 254	13 - 25	31.8	241	660	305	508	648	406	102	254	25.4	
F-15	2732009	13.6	178 - 432	13 - 51	69.4	394	864	432	686	876	635	178	432	50.8	
NS-15	2732018	13.6	178 - 432	13 - 51	69.4	394	864	432	686	876	635	178	432	50.8	
F-25	2732027	22.7	406 - 610	25 - 76	132	584	1219	565	914	1346	946	406	610	76.2	
NS-25	2732036	22.7	406 - 610	25 - 76	132	584	1219	565	914	1346	946	406	610	76.2	
F-35	2732045	31.8	406 - 914	41 - 102	235	762	1626	699	1219	1473	1346	406	914	102	
NS-35	2732054	31.8	406 - 914	41 - 102	235	762	1626	699	1219	1473	1346	406	914	102	

\* Maximum Proof Load is 2 times the Working Load Limit and design factor based on EN13155 and ASME B30.20. NOTE: : For beam clamps larger than 35 Tons, please contact the Crosby Special Engineered Products Department.

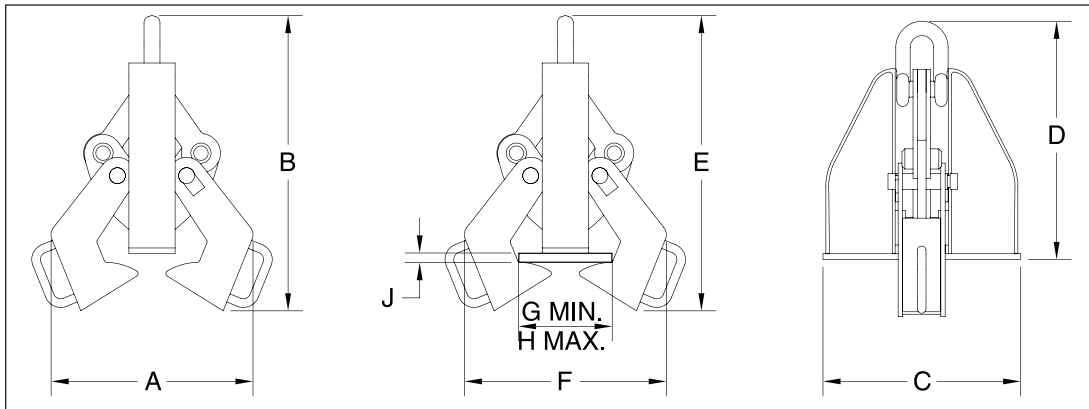

Base Stock No.	Base Dimensions (mm)						
	C	L	M	N	P	S	T
F-5	343	-	-	-	-	76.2	-
F-15	432	-	-	-	-	102	-
NS-15	432	12.7	165	114	19.1	102	63.5
F-25	565	-	-	-	-	140	-
NS-25	565	19.1	197	165	19.1	140	102
F-35	699	-	-	-	-	152	-
NS-35	699	19.1	229	216	19.1	152	114

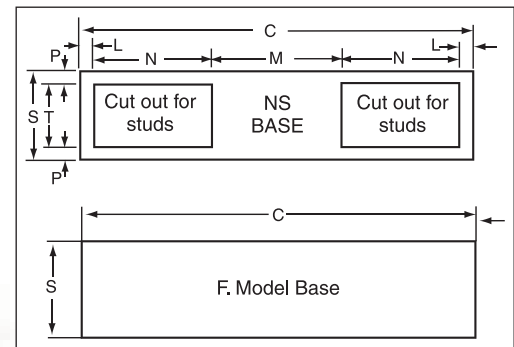

**CROSBY<sup>®</sup> LIFTING CLAMPS**

## CROSBY Clamps-Co® Barrier / Curb Grabs



CCBG

**Crosby Clamp-Co® Barrier Grabs provide a fast and efficient method for handling concrete road barriers.**

- Hands-free operation.
- Available with polyurethane pads or hardened steel jaw (Replacement kits available).
- Eliminates the need for slings, chokers and spreader bars.
- Individually Proof Tested to 2 times the Working Load Limit with certification.
- Finish - Red Paint.
- All sizes are **RFID EQUIPPED**.

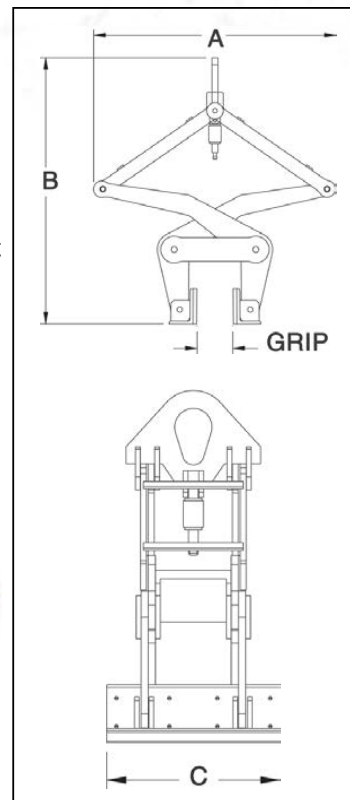

### Barrier Grab

Model No.	CCBG-150 Stock No.	Working Load Limit (kg)*	Weight Each (kg)	Grip Width (mm)	Dimensions (mm)		
					A	B	C
BG-9000	2734009	4.08	132	152 (min.)	1038	1140	457
				305 (max.)	1117	933	457

\* Design factor based on EN13155 and ASME B30.20.



CCCG

**Crosby Clamp-Co® Curb Grabs provide a fast and efficient method for handling large granite curbs.**

- Hands-free operation.
- Available with polyurethane pads or hardened steel jaw (Replacement kits available).
- Eliminates the need for slings, chokers and spreader bars.
- Individually Proof Tested to 2 times the Working Load Limit with certification.
- Finish - Red Paint.
- All sizes are **RFID EQUIPPED**.

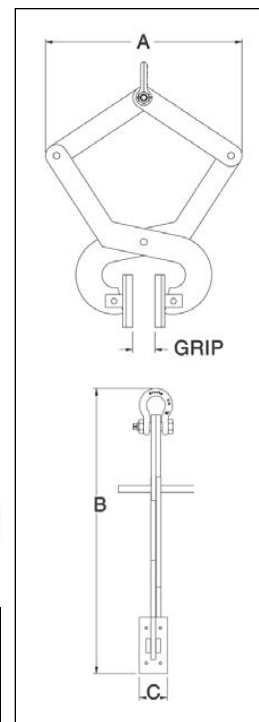

### Curb Grab

Model No.	CCBG-140 Stock No.	Working Load Limit (kg)*	Weight Each (kg)	Grip Width (mm)	Dimensions (mm)		
					A	B	C
CG-1400	2734000	635	16.8	102 (min.)	565	683	254
				178 (max.)	635	514	76.2

\* Design factor based on EN13155 and ASME B30.20.



CCPH

**Crosby Clamp-Co® Pipe Hooks provide a fast and efficient method for lifting pipe, tube or any similarly shaped fabrications.**

- Alloy steel plate construction.
- Equipped with a convenient handle.
- Equipped with a Bolt Type Shackle.
- Non marring inserts available.
- Used in pairs with 45° - 60° horizontal angle or 60° - 90° included angle.

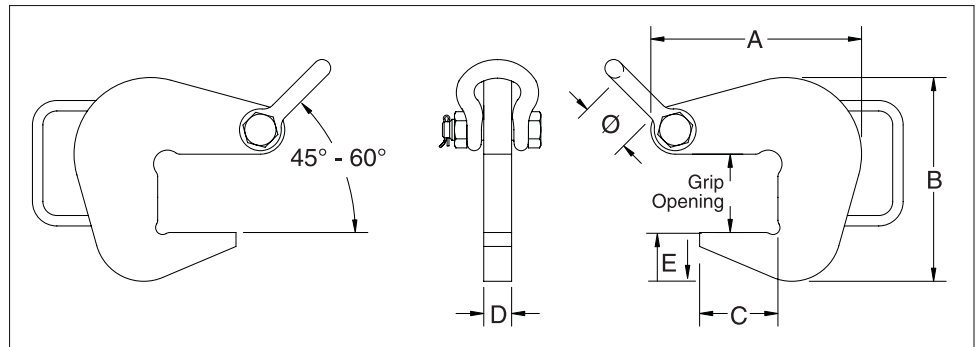

## Pipe Hooks

Model	Stock No.	Working Load Limit Per Pair (t)**	Grip (mm)	Weight Each (kg)	Dimensions (mm)						Shackle Size (in.)	Cast Aluminium Inserts*
					A	B	C	D	E	Ø		
PH-2	2734500	2	52.3	2.70	148	129	52.3	25.4	31.8	42.9	5/8	2734800 2734809
PH-4	2734509	4	71.4	4.56	192	186	71.4	25.4	44.4	42.9	5/8	2734818
PH-6	2734518	6	103	8.05	259	256	103	25.4	57.2	50.8	3/4	2734827
PH-10	2734527	10	154	17.5	376	383	154	25.4	88.9	68.3	1.0	2734836

\* See CCPHI chart for Pipe ID range.

\*\*Design factor based on EN13155 and ASME B30.20.

Contact our Specials Sales Department for custom Pipe Hooks or reference the special request form on page 489.

## Pipe Hook Inserts

- Interchangeable cast aluminium inserts for use with the CCPH Pipe Hook that minimizes thread and pipe damage.

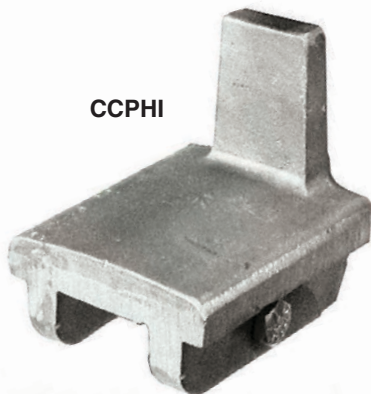

CCPHI

### CCPHI

Catalog Number	Stock No.	ID of Pipe (mm)
CCPHI	2734800	76 - 305
	2734809	305 - 457
	2734818	457 - 762
	2734827	762 - 1067
	2734836	1067 - 1329









# CROSBY TRAWLEX® PRODUCTS



# Crosby Trawlex®

## DESIGNED FOR THE RIGOURS OF COMMERCIAL FISHING

Crosby Trawlex® offers a range of chain and components specifically devised for the rigours of commercial fishing. From the outset, it has been created with the end user in mind. By designing the range of products with experienced trawler men and with the use of extensive seagoing research, Crosby Trawlex® has proven to be the most versatile and cost effective method of trawl rigging available.

The complete Crosby Trawlex® range of products is enriched with super-strength capabilities as a result of special steels and heat treatment used in the manufacturing process. The heat treatment also ensures that ductility is retained, resulting in the products being highly resistant to the effects of shock loading and wear.

## PROFILE CHAIN - THE SHAPE OF THINGS TO COME!

The real challenges to fishing gear when new, are set by the industry's severe environment. These conditions may result in early failures caused by wear and corrosion. The new Crosby Trawlex® Profile Chain has been designed to take up these challenges.

**Wear** – The revolutionary design and the use of wear resistant materials in Crosby Trawlex® Profile Chain have greatly reduced the effects of wear, the main cause of reduction in a chain's tensile strength, compared with traditional chain (fig1).



**Corrosion and Fatigue** – As yet, corrosion cannot be eliminated at an acceptable cost; however the increased contact areas of Crosby Trawlex® Profile Chain (fig2), together with the use of improved materials and heat treatment, have radically reduced the chances of stress and fatigue and therefore the effects of corrosion.



# BENEFIT FROM OUR EXPERTISE

Compare Crosby Trawlex® chain and components to other products on the market and you will soon see the benefits of using Crosby Trawlex®.

Operating costs of the trawler are reduced as a result of the high strength, wear resistance and shock resistance of the products. The ingenious design of Crosby Trawlex® parts allows a wide range of components to be used in different rig positions in all methods of trawling.

Time is saved by incorporating a unique clevis and load pin assembly method. Less time is spent assembling a rig, and only the simplest tools are required for the process.

Time is also saved as a result of the superior lightness of Crosby Trawlex® chains and parts. Handling is much easier and the products are less bulky to transport.

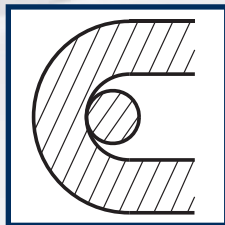

Round Chain

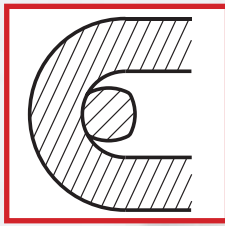

Profile Chain

Fig 2. Link contact area cross section.

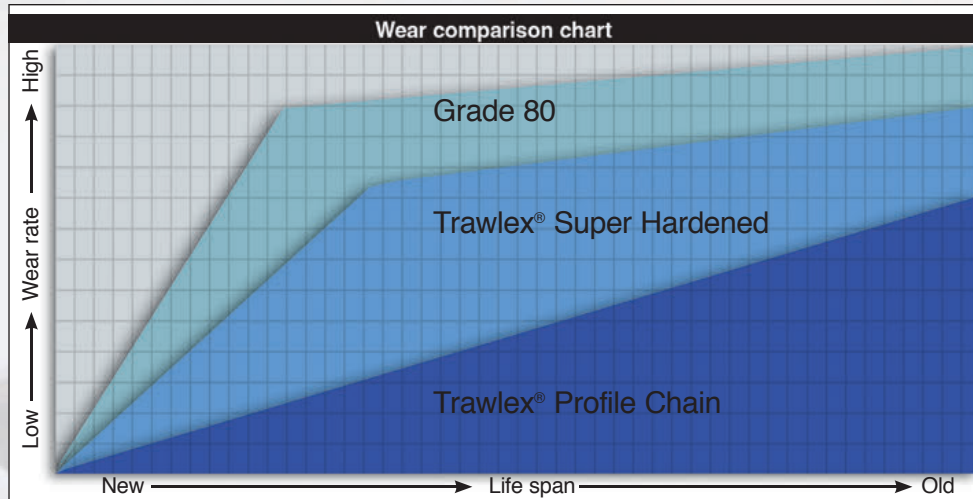

Fig 1.

## Trawlex® Benefits

- **Innovators** – World's first chain maker to attain BS EN ISO 9001.
- **Diversity** – Widest range of chain sizes, calibrated stability.
- **Testing** – 100% non-destructive testing on all products.
- **Properties** – Fatigue life up to 4 times specification plus improved resistance to stress corrosion.
- **Performance** – Materials optimised for low temperature conditions.
- **Weight** – Lighter and less bulky products.
- **Research** – Trawlex® has a comprehensive research policy to constantly seek improvements to our products.





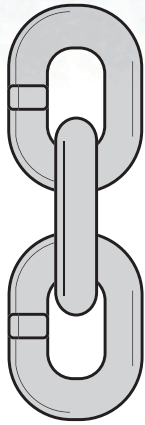

All breaking loads are in metric tonnes. To maximize the benefits of the improved strength of the chain, only use compatible Trawlex® fittings.

**Crosby Trawlex® Short Link Chain**

Model	Stock No.	Chain Dia. (mm)	Link Dimensions (mm)		Breaking Load (t)		Weight (kg.)	Standard Length (m)
			Pitch	Width	Trawlex®	Grade 80		
TRAW-SL	2781650	10	30	14	15.5	12	2.2	200
TRAW-SL	2781652	13	39	18.1	26.5	20	3.61	150
TRAW-SL	2781635	16	48	22.4	41	30	5.41	110
TRAW-SL	2781644	19	57	26.6	57	45	7.81	75

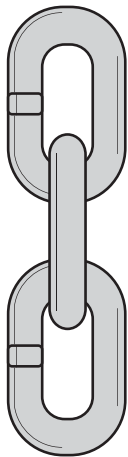

**Crosby Trawlex® Mid Link Chain**

Model	Stock No.	Chain Dia. (mm)	Link Dimensions (mm)		Breaking Load (t)		Weight (kg.)	Standard Length (m)
			Pitch	Width	Trawlex®	Grade 80		
TRAW-ML	2784579	10	40	15	15.5	12	1.85	250
TRAW-ML	2784561	13	52	19.5	26.5	20	3.21	150
TRAW-ML	2784507	16	64	22.4	41	30	4.86	110
TRAW-ML	2784516	16	64	22.4	41	30	4.86	600
TRAW-ML	2781653	16	64	22.4	41	30	4.86	110
TRAW-ML	2784534	16	64	22.4	41	30	4.86	600
TRAW-ML	2784570	19	76	27	57	45	6.92	75
TRAW-ML	2784525	19	76	27	57	45	6.92	300
TRAW-ML	2781662	19	76	27	57	45	6.92	75
TRAW-ML	2784543	19	76	27	57	45	6.92	300
TRAW-ML	2781671	22	86	26	70	60	9.24	60
TRAW-ML	2784552	22	86	26	70	60	9.24	110
TRAW-ML	2781680	26	92	30	95	85	13.66	50

 Denotes Profile Chain™

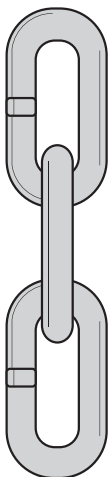

**Crosby Trawlex® Long Link Chain**

Model	Stock No.	Chain Dia. (mm)	Link Dimensions (mm)		Breaking Load (t)		Weight (kg.)	Standard Length (m)
			Pitch	Width	Trawlex®	Grade 80		
TRAW-LL	2781699	9	53	15	12.5	10	1.36	200
TRAW-LL	2781706	11	63	18	18.5	15	2.03	150
TRAW-LL	2781715	13	80	22	26.5	20	2.83	150
TRAW-LL	2781720	13	80	22	26.5	20	2.83	600
TRAW-LL	2784339	16	100	24.5	40	30	4.34	100
TRAW-LL	2784348	16	100	24.5	40	30	4.34	600
TRAW-LL	2781724	16	100	24.5	40	30	4.34	100
TRAW-LL	2784320	16	100	24.5	40	30	4.34	600
TRAW-LL	2784357	19	100	25	57	45	6.31	108
TRAW-LL	2781733	19	100	25	57	45	6.31	108
TRAW-LL	2781742	22	120	35.5	70	60	8.74	70
TRAW-LL	2781751	28	150	46	105	95	14.41	50

 Denotes Profile Chain™

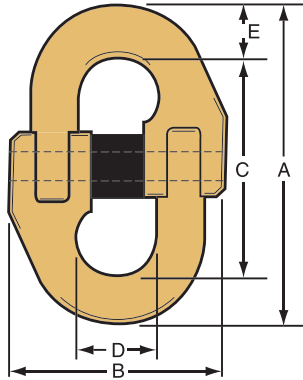

## Crosby Trawlex® Component Connector TLN

Model	Stock No.	Chain Dia. (mm)	Dimensions (mm)					Weight (kg)
			A	B	C	D	E	
TL7N	2780583	7	67	49	48	14.3	9	.11
TL10N	2780592	10	89	66	64	19.2	13	.36
TL13N	2780609	13	118	85	85	26.5	17	.66
TL16N	2780618	16	144	96	106	32	19	1.08
TL19N	2780627	19	168	115	122	38.5	23	1.77
TL23N	2780636	23	206	140	150	49	28	2.8
TL26N	2780645	26	230	163	166	57	32	4.4
TL32N	2780654	32	278	210	200	63	39	8.4

Individually Proof Tested to 2.5 x WLL.

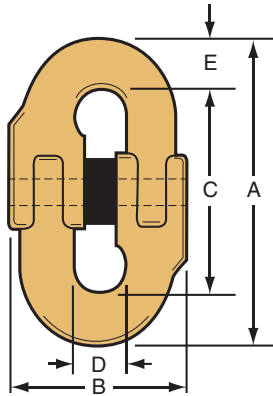

## Crosby Trawlex® Chain Connector KJ

Model	Stock No.	Chain Dia. (mm)	Dimensions (mm)					Weight (kg)
			A	B	C	D	E	
KJ7	2780663	7	56	34	41	8	7.5	.09
KJ10	2780672	10	73	45	51	11.5	11	.27
KJ13	2780681	13	94	61	65	14.7	14	.44
KJ16	2780690	16	120	75	84	19.1	18	.83
KJ19	2780707	19	142	90	100	22.9	21	1.42

Individually Proof Tested to 2.5 x WLL.

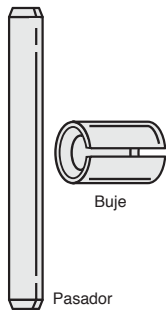

## Crosby Trawlex® Chain & Component Connector Spares

Component Connector TL				Chain Connector KJ			
Pin		Bush		Pin		Bush	
Model	Stock No.	Model	Stock No.	Model	Stock No.	Model	Stock No.
TL7PIN	2784222	TL7BUSH	2784142	KJ7PIN	2783116	KJ7BUSH	2783063
TL10PIN	2784231	TL10BUSH	2784151	KJ10PIN	2783125	KJ10BUSH	2783072
TL13PIN	2784240	TL13BUSH	2784160	KJ13PIN	2783134	KJ13BUSH	2783081
TL16PIN	2784259	TL16BUSH	2784179	KJ16PIN	2783143	KJ16BUSH	2783090
TL19PIN	2784268	TL19BUSH	2784188	KJ19PIN	2783152	KJ19BUSH	2783107
TL23PIN	2784277	TL23BUSH	2784197	-	-	-	-
TL26PIN	2784286	TL26BUSH	2784204	-	-	-	-
TL32PIN	2784295	TL32BUSH	2784213	-	-	-	-

Full details of the load and retaining pins required for each Trawlex® component are shown on Trawlex® Data Sheet TX191, available on request.



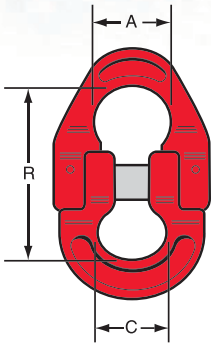

**Crosby Trawlex® Auxiliary Link KAL**

Model	Stock No.	Chain Dia. (mm)	Dimensions (mm)			Breaking Load (tonnes)	Weight (kg)
			R	C	A (dia.)		
KAL7	2780253	2x7	79	31	34	15	.52
KAL10	2780262	2x10	110	43	46	30	1.74
KAL13	2780271	2x13	143	57	60	45	2.89
KAL16	2780280	2x16	187	71	76	70	6
KAL19	2780299	2x19	232	90	90	100	10.25

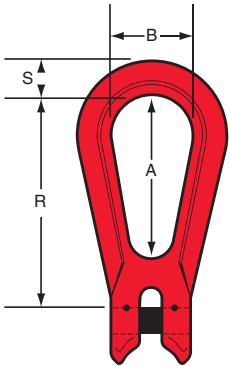

**Crosby Trawlex® Egg Link KSS**

Model	Stock No.	Chain Dia. (mm)	Dimensions (mm)				Weight (kg)
			A	B	R	S	
KSS7N	2780422	7	70	35	92	13	.27
KSS10N	2780431	10	102	51	132	18.5	.74
KSS13N	2780440	13	137	67	177	26	1.92
KSS16N	2780459	16	172	83	220	31	3.17
KSS19N	2780468	19	203	98	261	37	5.58
KSS23N	2780477	23	238	114	305	40	8.42
KSS26N	2780486	26	273	133	351	46	14.51

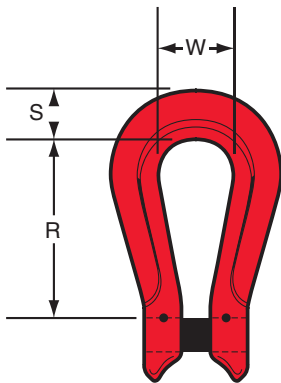

**Crosby® Trawlex® Kupler K**

Model	Stock No.	Chain Dia. (mm)	Dimensions (mm)			Weight (kg)
			R	W	S	
K7N	2780495	7	60	26	12.5	.15
K10N	2780501	10	73	35	19	.47
K13N	2780510	13	95	45	25	1.01
K16N	2780529	16	118	54	29	1.66
K19N	2780538	19	134	64	34	2.78
K23N	2780547	23	121	64	45	4.26
K26N	2780556	26	140	82	48	6.30
K32N	2780574	32	178	96	64	11.48

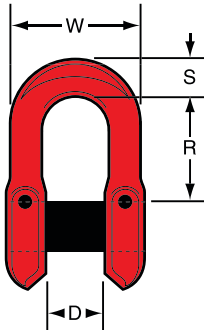

## Crosby Trawlex® 'D' Shackle TXRC

Model	Stock No.	Chain Dia. (mm)	Dimensions (mm)				Weight (kg)
			R	W	D	S	
TXRC16	2781760	16	57	72	35	22	.9

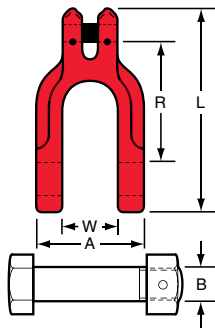

## Crosby Trawlex® Dog Shackle KDL

Model	Stock No.	Chain Dia. (mm)	Dimensions (mm)					Weight (kg)
			L	W	R	A	B	
KDL7N	2781314	7	59	35	71	86	19	.71
KDL10N	2781323	10	166	44	104	83	22	1.36
KDL13N	2781332	13	113	57	138	137	29	3.02
KDL16N	2781341	16	141	73	173	175	35	6.18
KDL19N	2781350	19	170	86	203	205	44	10.62

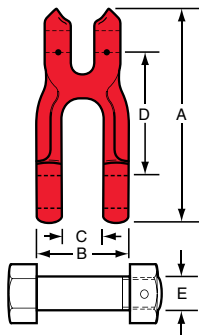

## Crosby Trawlex® Narrow Jaw Shackle KDN

Model	Stock No.	Chain Dia. (mm)	Dimensions (mm)					Weight (kg)
			A	B	C	D	E	
KDN7N	2781369	7	98	42	20	57	14	.26
KDN10N	2781378	10	139	58	28	83	20	.85
KDN13N	2781387	13	179	74	35	108	24	1.68
KDN16N	2781396	16	216	90	44	127	30	3.14

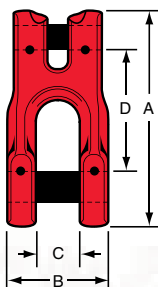

## Crosby Trawlex® Clevis Shackle TXCS

Model	Stock No.	Chain Dia. (mm)	Dimensions (mm)				Weight (kg)
			A	B	C	D	
TXCS16	2781788	16	200	90	45	113	2.5

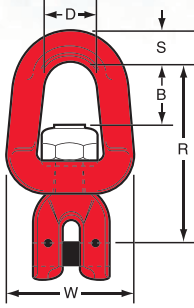

Crosby Trawlex® Swivel TXSW

Model	Stock No.	Chain Dia. (mm)	Dimensions (mm)					Weight (kg)
			R	W	D	B	S	
TXSW13	2781797	13	127	94	41	51	22	1.93
TXSW16	2781804	16	162	111	51	60	29	3.29

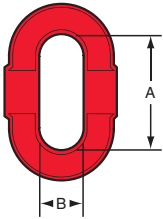

Crosby Trawlex® Double Nibbed Link TXDR

Model	Stock No.	Chain Dia. (mm)	Dimensions (mm)		Weight (kg)
			A (pitch)	B (width)	
TXDR13	2781813	13	108	54	.89
TXDR16	2781822	16	127	63	1.6

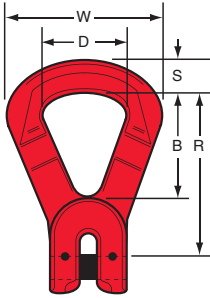

Crosby Trawlex® Recessed Link TXRL

Model	Stock No.	Chain Dia. (mm)	Dimensions (mm)					Weight (kg)
			R	W	D	B	S	
TXRL13	2781831	13	125	117	63	84	22	1.6
TXRL16	2781840	16	156	156	89	108	27	2.72

Note: 19-22mm sizes available upon request.

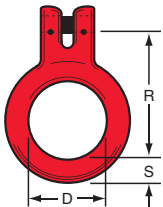

Crosby Trawlex® Kelly's Eye TXKE

Model	Stock No.	Chain Dia. (mm)	Dimensions (mm)			Weight (kg)
			R	D	S	
TXKE16	2781859	16	187	95	28	4.42

Note: 19-22mm sizes available upon request.

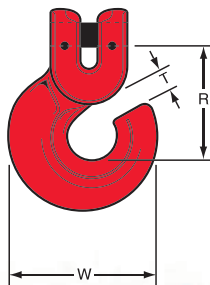

Crosby Trawlex® 'G' Hook TXG

Model	Stock No.	Chain Dia. (mm)	Dimensions (mm)			Weight (kg)
			R	T	W	
TXG13	2781868	13	82	16	106	1.51
TXG16	2781877	16	100	20	114	2.38

Note: 19-22mm sizes available upon request.





All Trawlex® hooks in the KHX series are designed so that the latch cannot open under load and require pressure on the trigger to release the hook when the load is grounded.

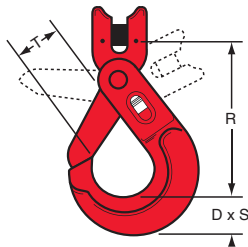

## Crosby Trawlex® Self-Locking Hook KHX C

Model	Stock No.	Chain Dia. (mm)	Dimensions (mm)				Weight (kg)
			R	D	S	T	
KHX7C	2781074	7	117	25	19	36	.82
KHX10C	2781083	10	146	32	24	47	1.51
KHX13C	2781092	13	181	42	30	56	3.15
KHX16C	2781119	16	223	49	36	70	5.27

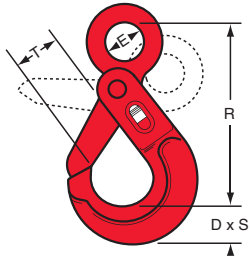

## Crosby Trawlex® Self-Locking Hook KHX E

Model	Stock No.	Chain Dia. (mm)	Dimensions (mm)					Weight (kg)
			R	D	S	T	E	
KHX7E	2781118	7	142	25	19	36	23	.85
KHX10E	2781127	10	175	32	24	47	30	1.15
KHX13E	2781136	13	217	42	30	56	40	3.06
KHX16E	2781145	16	272	49	36	70	51	5.24
KHX19E	2781154	19	277	66	53	80	65	9.5
KHX23E	2781163	23	315	69	63	92	75	13.9

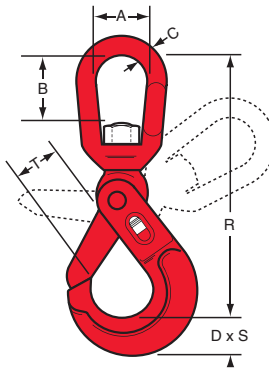

## Crosby Trawlex® Swivel Self-Locking Hook KHX S

Model	Stock No.	Chain Dia. (mm)	Dimensions (mm)							Weight (kg)
			A	B	R	D	S	T	C (dia.)	
KHX7S	2781172	7	42	42	202	25	19	36	12	1.24
KHX10S	2781181	10	50	46	235	32	24	47	15	2.11
KHX13S	2781190	13	60	62	293	42	30	56	19	4.28

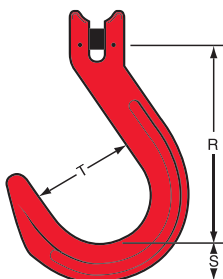

## Crosby Trawlex® Foundry Hook KF

Model	Stock No.	Chain Dia. (mm)	Dimensions (mm)			Weight (kg)
			R	T	S	
KF7N	2781252	7	117	64	24	.79
KF10N	2781261	10	137	76	32	1.74
KF13N	2781270	13	165	89	41	3.45
KF16N	2781289	16	222	114	52	7.4
KF19N	2781298	19	248	127	61	11.82



# Setting a “World Class” Standard in Subsea Lifting

Crosby® is a trusted partner in the Subsea Industry, priding ourselves on being the leading innovator with quality service to back it up. We understand that the unique needs and demanding applications involved in subsea work require products and training that are time-tested and proven.



**Offshore Platform Applications**



**Underwater / Subsea ROV Applications**







# CROSBY KUPLEX®

SETTING THE  
STANDARD IN  
CHAIN LIFTING  
SYSTEMS

## KUPLEX 8 + 10



# KUPLEX 8 + 10

## DUAL GRADE SYSTEM

Crosby KUPLEX 8+10 is a unique dual grade chain sling system. Advanced technical design, with precise material and heat treatment selection, has enhanced the high wear and fatigue properties for which Crosby KUPLEX is renowned throughout the world.

Crosby KUPLEX 8+10 dual rated components can now be combined with either Crosby KUPLEX Grade 8 or Grade 10 chain for the most versatile system ever produced (see dual load chart on page 441).

A range of components is available from 7mm up to 32mm allowing a wide variety of slings to be supplied with load ratings up to 85 tonnes.

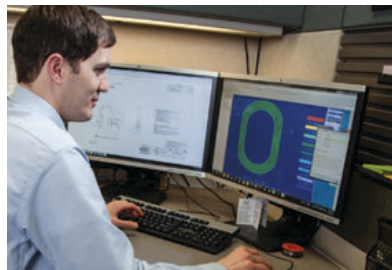

Crosby KUPLEX 8+10 components have been designed using the latest CAD facilities which allows for a full stress analysis of each component prior to manufacture.



Crosby KUPLEX 8+10 components are subjected to non-destructive testing giving the user complete peace of mind.

Crosby KUPLEX Grade 8 and Grade 10 chains are subjected to non-destructive tests, calibration and visual inspection.

Crosby KUPLEX 8+10 components and KUPLEX Grade 10 chain are 25% stronger than existing Grade 8 components and chain.

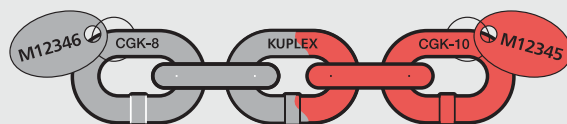
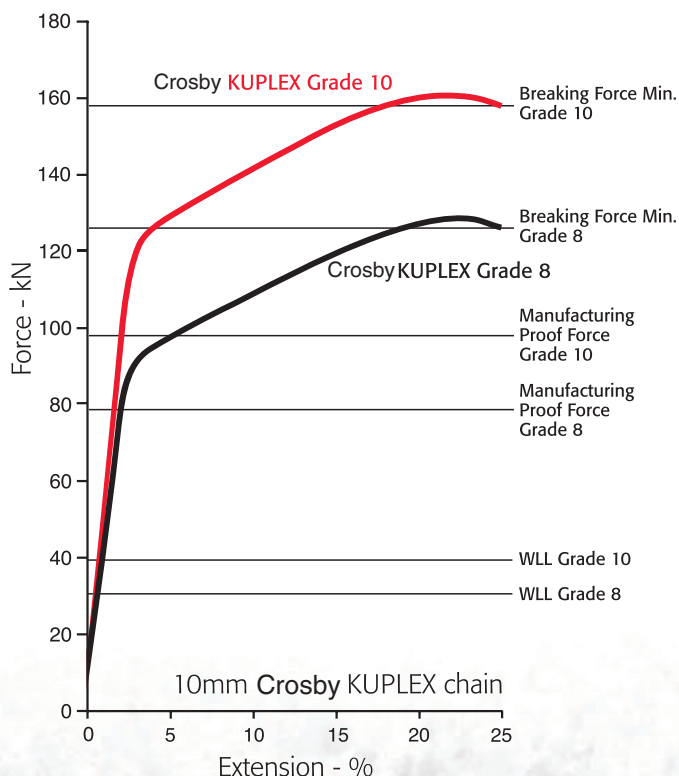

The Crosby KUPLEX chain batch number is marked on the box and on a metal tag attached to the end of the chain. All Crosby KUPLEX chain is either double embossed with Crosby KUPLEX one side and the Grade 8 or 10 on the other, or single embossed with CGK8 to denote Crosby KUPLEX Grade 8 or CGK10 to denote Crosby KUPLEX Grade 10, every 20th link or 1 meter, whichever is the lesser distance.

Crosby KUPLEX components are marked with part numbers and traceability codes.

Brand Name and Dual Grade  
Crosby KUPLEX

8+10

Part Number	KDN7N
Manufacturer	P
Die Run Number	2
Year of Manufacture	E
Steel Cast Number	384
Grouped together as	P2E384
Origin	UK

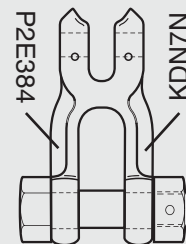

Crosby can provide certified material (mill) analysis for each production lot, traceable by the Product Identification Code (PIC).

The Crosby KUPLEX 8+10 system is certified to European and International requirements making it a worldwide system.

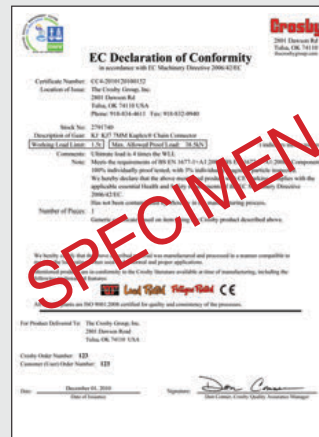

# KUPLEX 8 + 10

## WORKING LOAD LIMITS - TONNES

The working load limits (WLL) listed in the table below are the maximum weights which slings are designed to carry in general lifting service according to the standard uniform load method of rating.

In exceptionally hazardous conditions or in any other circumstances which might indicate a need for a WLL lower than the designed figure, the degree of hazard should be assessed by a competent person and the working load limit adjusted accordingly. The WLL, which should be marked on the sling itself, or on a securely fixed metal tag, must not be exceeded in any circumstances.

Chain Dia. mm	Grade	Single Leg	Two Leg		Three and Four Leg		Endless
			0° < β ≤ 45°	45° < β ≤ 60°	0° < β ≤ 45°	45° < β ≤ 60°	
			Factor 1	Factor 1.4	Factor 1	Factor 2.1	
7	8	1.5	2.12	1.5	3.15	2.24	2.5
7	10	2	2.8	2	4.2	3	3.2
8	8	2	2.8	2	4.2	3	3.2
10	8	3.15	4.25	3.15	6.7	4.75	5
10	10	4.0	5.6	4	8.4	6	6.4
13	8	5.3	7.5	5.3	11.2	8	8.5
13	10	6.7	9.5	6.7	14	10	10.7
16	8	8	11.2	8	17	11.8	12.5
16	10	10	14	10	21.2	15	16
19	8	11.2	16	11.2	23.6	17	18
19	10	14	20	14	30	21	22.4
23	8	16	23.6	16	35.5	25	26.5
23	10	21	29.5	21	44	31.5	33.5
26	8	21.2	30	21.2	45	31.5	33.5
26	10	27	38	27	57	40	43
32	8	31.5	45	31.5	67	47.5	50
32	10	40	56	40	85	60	65

CROSBY KUPLEX Grade 8 working load limits are in accordance with EN 818-4



**NOTE:** Never exceed the working load limit marked on the sling. Never use a sling at angles greater than 60° from the vertical.

### The load imposed on a sling leg increases as the angle of the leg from vertical increases

Account is taken of this fact when calculating working load limits. For example, a 10mm two-leg sling to be used at angle of 45° from the vertical (90° included angle) will have a WLL 1.4 times that of a 10mm single leg sling when used vertical, and not 2 times the single leg. That same working load limit applies to all angles from 0° -45° (0° -90° included angle.) Where there is likely to be a need to use a sling at an angle greater than 45° from the vertical, the sling should have additional markings showing the reduced WLL applying at angles from 45° -60° from the vertical (included angles from 90° -120°). Refer to 'Restrictions on the Angles of Use' on page 459.

### Alternative Method of Rating

An alternative method of rating may be used for specific lifting applications where the angle at which the sling's legs are disposed is predetermined. This method allows greater working load limits at angles less than 45° from the vertical, always assuming that the sling legs are disposed symmetrically with each leg accepting an equal share of the load to be lifted. For further details refer to your Crosby KUPLEX distributor.



Single Leg Slings

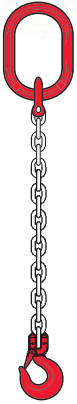

Single Leg fitted with KHN L Sling Hooks

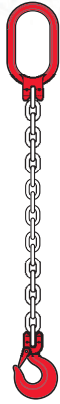

Single Leg fitted with KS N Kuplink and KHN L Sling Hooks

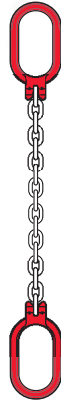

Single Leg fitted with KS N Kuplinks each end



Single Leg fitted with KSS N Reeveable Link each end

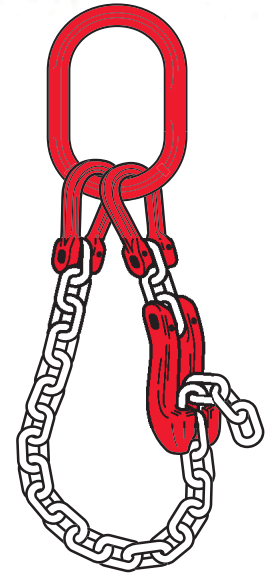

KSC Shortening Clutch in use

Basket configuration

Master Links



KM  
7mm - 32mm



KSS N  
7mm - 26mm



KS N  
7mm - 16mm

Kupler



K N  
7mm - 32mm

Shortening Clutch



KSC N  
7mm - 19mm



KSC  
7mm - 32mm

Terminal Fittings - Availability Chart

Chain Dia. (mm)	Grade	Working Load Limit (t)											
		KHN L	KHX C	KHX E	KHX S	KC N	KF N	KHW N	KDN N	KDL N	KSS N	KS N	TL N
7	8	1.5	1.5	1.5	1.5	1.5	1.5	1.5	1.5	1.5	1.5	1.5	1.5
7	10	2	2	2	2	2	2	2	2	2	2	2	-
8	8	2	2	2	2	2	2	2	2	2	2	2	2
10	8	3.15	3.15	3.15	3.15	3.15	3.15	3.15	3.15	3.15	3.15	3.15	3.15
10	10	4	4	4	4	4	4	4	4	4	4	4	-
13	8	5.3	5.3	5.3	5.3	5.3	5.3	5.3	5.3	5.3	5.3	5.3	5.3
13	10	6.7	6.7	6.7	6.7	6.7	6.7	6.7	6.7	6.7	6.7	6.7	-
16	8	8	8	8	-	8	8	8	8	8	8	8	8
16	10	10	10	10	-	10	10	10	10	10	10	10	-
19	8	11.2	-	11.2	-	11.2	11.2	-	-	11.2	11.2	-	11.2
19	10	14	-	14	-	14	14	-	-	14	14	-	-
23	8	16	-	16	-	-	16	-	-	-	16	-	16
23	10	21	-	21	-	-	21	-	-	-	21	-	-
26	8	21.2	-	-	-	-	-	-	-	-	21.2	-	21.2
26	10	27	-	-	-	-	-	-	-	-	27	-	-
32	8	31.5	-	-	-	-	-	-	-	-	-	-	31.5
32	10	40	-	-	-	-	-	-	-	-	-	-	-

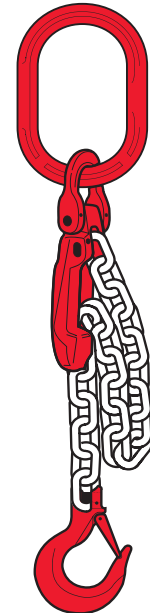

KSC N Shortening Clutch in use

Note that the loaded end of the chain must come out of the bottom of both types of clutch.





Two Leg Slings

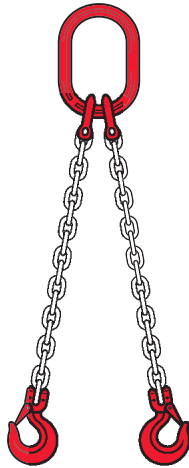

Two Leg fitted with KHN L sling hooks

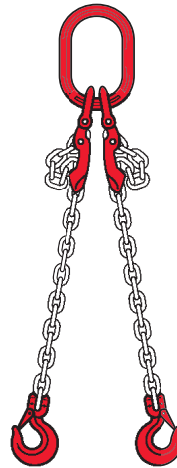

Two Leg fitted with KSCN Shortening Clutches and KHN L sling hooks

Master Links



KM  
7mm - 32mm

Kupler



KN  
7mm - 32mm

Shortening Clutch



KSCN  
7mm - 19mm



KSC  
7mm - 32mm

Terminal Fittings - Availability Chart

Chain Dia. (mm)	Grade	Working Load Limit (t.)											
		KHN L	KHX C	KHX E	KHX S	KC N	KF N	KHW N	KDN N	KDL N	KSS N	KS N	TL N
7	8	2.12	2.12	2.12	2.12	2.12	2.12	2.12	2.12	2.12	2.12	2.12	2.12
7	10	2.8	2.8	2.8	2.8	2.8	2.8	2.8	2.8	2.8	2.8	2.8	-
8	8	2.8	2.8	2.8	2.8	2.8	2.8	2.8	2.8	2.8	2.8	2.8	2.8
10	8	4.25	4.25	4.25	4.25	4.25	4.25	4.25	4.25	4.25	4.25	4.25	4.25
10	10	5.6	5.6	5.6	5.6	5.6	5.6	5.6	5.6	5.6	5.6	5.6	-
13	8	7.5	7.5	7.5	7.5	7.5	7.5	7.5	7.5	7.5	7.5	7.5	7.5
13	10	9.5	9.5	9.5	9.5	9.5	9.5	9.5	9.5	9.5	9.5	9.5	-
16	8	11.2	11.2	11.2	-	11.2	11.2	11.2	11.2	11.2	11.2	11.2	11.2
16	10	14	14	14	-	14	14	14	14	14	14	14	-
19	8	16	-	16	-	16	16	-	-	16	16	-	16
19	10	20	-	20	-	20	20	-	-	20	20	-	-
23	8	23.6	-	23.6	-	-	23.6	-	-	-	23.6	-	23.6
23	10	29.5	-	29.5	-	-	29.5	-	-	-	29.5	-	-
26	8	30	-	-	-	-	-	-	-	-	30	-	30
26	10	38	-	-	-	-	-	-	-	-	38	-	-
32	8	45	-	-	-	-	-	-	-	-	-	-	45
32	10	56	-	-	-	-	-	-	-	-	-	-	-

Working Load Limits are for Two Leg Slings at 0° to 45°

KUPLEX® +10  
 DUAL-GRADE SYSTEM  
 8

CROSBY® KUPLEX®

Three Leg Slings

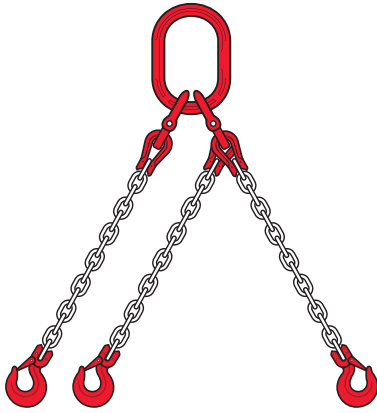

Three Leg fitted with KHN L Sling Hooks



Three Leg fitted with KSCN Shortening Clutches and KHN L Sling Hooks

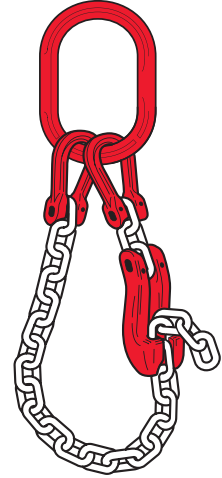

KSC Shortening Clutch in use. Basket configuration

Master Links

Kupler

Shortening Clutch



KMML  
7mm - 32mm



KM  
7mm - 32mm



KAL  
7mm - 19mm



K N  
7mm - 32mm



KSC N  
7mm - 19mm



KSC  
7mm - 32mm



KSC N Shortening Clutch in use

Terminal Fittings - Availability Chart

Chain Dia. (mm)	Grade	Working Load Limit (t)											TL N	
		KHN L	KHX C	KHX E	KHX S	KC N	KF N	KHW N	KDN N	KDL N	KSS N	KS N		
7	8	3.15	3.15	3.15	3.15	3.15	3.15	3.15	3.15	3.15	3.15	3.15	3.15	-
7	10	4.2	4.2	4.2	4.2	4.2	4.2	4.2	4.2	4.2	4.2	4.2	4.2	-
8	8	4.2	4.2	4.2	4.2	4.2	4.2	4.2	4.2	4.2	4.2	4.2	4.2	4.2
10	8	6.7	6.7	6.7	6.7	6.7	6.7	6.7	6.7	6.7	6.7	6.7	6.7	6.7
10	10	8.4	8.4	8.4	8.4	8.4	8.4	8.4	8.4	8.4	8.4	8.4	8.4	-
13	8	11.2	11.2	11.2	11.2	11.2	11.2	11.2	11.2	11.2	11.2	11.2	11.2	11.2
13	10	14	14	14	14	14	14	14	14	14	14	14	14	-
16	8	17	17	17	-	17	17	17	17	17	17	17	17	17
16	10	21.2	21.2	21.2	-	21.2	21.2	21.2	21.2	21.2	21.2	21.2	21.2	-
19	8	23.6	-	23.6	-	23.6	23.6	-	-	23.6	23.6	-	23.6	-
19	10	30	-	30	-	30	30	-	-	30	30	-	-	-
23	8	35.5	-	35.5	-	-	35.5	-	-	-	35.5	-	35.5	-
23	10	44	-	44	-	-	44	-	-	-	44	-	-	-
26	8	45	-	-	-	-	-	-	-	-	45	-	45	-
26	10	57	-	-	-	-	-	-	-	-	57	-	-	-
32	8	67	-	-	-	-	-	-	-	-	-	-	67	-
32	10	85	-	-	-	-	-	-	-	-	-	-	-	-

Note that the loaded end of the chain must come out of the bottom of both types of clutch.

Working Load Limits are for Three Leg Slings at 0° to 45°



### Four Leg Slings



Four Leg fitted with KHN L Sling Hooks



Four Leg fitted with KSC-N Shortening Clutches and KHN L Sling Hooks

#### Master Links



KMM L  
7mm - 32mm



KM  
7mm - 32mm



KAL  
7mm - 19mm

#### Kupler



K N  
7mm - 32mm

#### Shortening Clutch



KSC N  
7mm - 19mm



KSC  
7mm - 32mm

### Terminal Fittings - Availability Chart

Chain Dia. (mm)	Grade	Working Load Limit (t)											
7	8	3.15	3.15	3.15	3.15	3.15	3.15	3.15	3.15	3.15	3.15	3.15	3.15
7	10	4.2	4.2	4.2	4.2	4.2	4.2	4.2	4.2	4.2	4.2	4.2	-
8	8	4.2	4.2	4.2	4.2	4.2	4.2	4.2	4.2	4.2	4.2	4.2	4.2
10	8	6.7	6.7	6.7	6.7	6.7	6.7	6.7	6.7	6.7	6.7	6.7	6.7
10	10	8.4	8.4	8.4	8.4	8.4	8.4	8.4	8.4	8.4	8.4	8.4	-
13	8	11.2	11.2	11.2	11.2	11.2	11.2	11.2	11.2	11.2	11.2	11.2	11.2
13	10	14	14	14	14	14	14	14	14	14	14	14	-
16	8	17	17	17	-	17	17	17	17	17	17	17	17
16	10	21.2	21.2	21.2	-	21.2	21.2	21.2	21.2	21.2	21.2	21.2	-
19	8	23.6	-	23.6	-	23.6	23.6	-	-	23.6	23.6	-	23.6
19	10	30	-	30	-	30	30	-	-	30	30	-	-
23	8	35.5	-	35.5	-	-	35.5	-	-	-	35.5	-	35.5
23	10	44	-	44	-	-	44	-	-	-	44	-	-
26	8	45	-	-	-	-	-	-	-	-	45	-	45
26	10	57	-	-	-	-	-	-	-	-	57	-	-
32	8	67	-	-	-	-	-	-	-	-	-	-	67
32	10	85	-	-	-	-	-	-	-	-	-	-	-

Working Load Limits are for Three Leg Slings at 0° to 45°

KUPLEX® +10  
 DUAL GRADE SYSTEM  
 +8



Special Purpose Slings



Two-leg Basket Sling

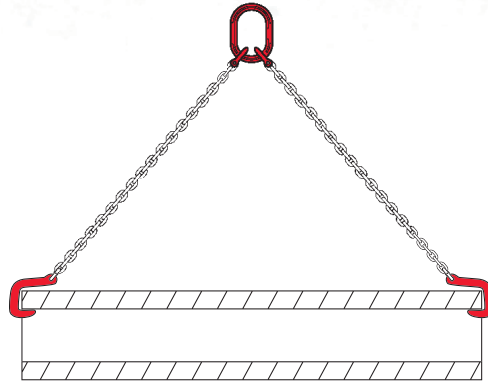

Pipe Sling

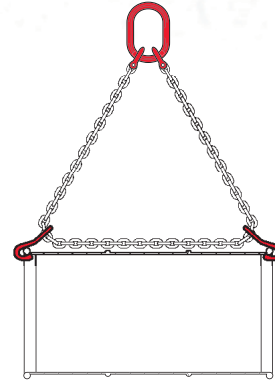

Drum Sling

Master Links



KMML  
7mm - 32mm



KM  
7mm - 32mm



KAL  
7mm - 19mm

Kupler



K N  
7mm - 32mm

Shortening Clutch



KSC N  
7mm - 19mm





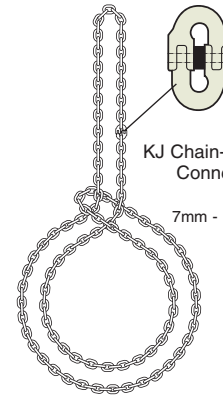



KSC  
7mm - 32mm



KJ Chain-to-Chain  
Connector

7mm - 19mm

Terminal Fittings - Availability Chart

Chain Dia. (mm)	Grade	Working Load Limit (t)						
		 KPH10 USED IN PAIRS	 KD USED IN PAIRS	 KB 1 LEG 2 LEG		 SINGLE BASKET	 ENDLESS DOUBLE BASKET	 IN CHOKE
7	8	-	1.5	1.5	2.12	2.12	3.15	2.5
7	10	-	2.0	2.0	2.8	2.8	4.2	-
8	8	-	2.0	2.0	2.8	2.8	4.2	3.2
10	8	4.25	-	-	-	4.25	6.7	5
10	10	5.6	-	-	-	5.6	8.4	-
13	8	Note: Sling rated at minimum 30° from the vertical (60° included angle)  MUST BE USED IN PAIRS	Note: Sling rated at minimum 30° from the vertical (60° included angle)  MUST BE USED IN PAIRS	-	-	7.5	11.2	8.5
13	10			-	-	9.5	14	-
16	8			-	-	11.2	17	12.5
16	10			-	-	14	21.2	-
19	8			-	-	16	23.6	18
19	10			-	-	20	30	-
23	8			-	-	23.6	35.5	-
23	10			-	-	29.5	44	-
26	8			-	-	30	45	-
26	10			-	-	38	57	-
32	8	-	-	45	67	-		
32	10	-	-	56	85	-		

Working Load Limits are for slings as illustrated.



### Technical Details

All Crosby KUPLEX chain meets the dimensional requirements of BS EN 818-2 and ISO 3076. All Crosby KUPLEX chain is either double embossed with Crosby KUPLEX one side and the Grade 8 or 10 on the other, or single embossed with CGK-8 to denote Crosby KUPLEX Grade 8 or CGK-10 to denote Crosby KUPLEX Grade 10, every 20th link or 1 meter, whichever is the lesser distance.

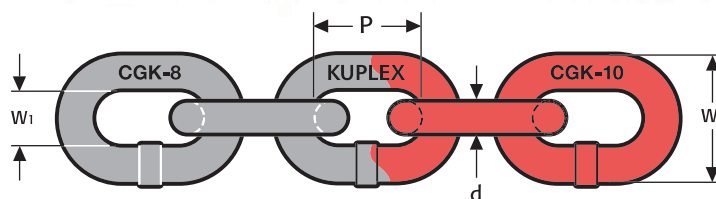

### Dimensions and Weights

Nominal Size (d) Diameter mm	Crosby Stock No.	Grade	Nominal Pitch (p) mm	Maximum External Width (W <sub>2</sub> ) mm	Minimum Internal Width (W <sub>1</sub> ) mm	Approx. Weight kg/m	Meters / drum
7	1245125	8	21	25.9	9.1	1.09	200
	1210097	10					
8	1245055	8	24	29.62	10.4	1.4	200
	1245125	8					
10	1210097	10	30	37	13	2.2	200
	1245195	8					
13	1210118	10	39	48.1	16.9	3.62	150
	1245265	8					
16	1210139	10	48	59.2	20.8	5.42	100
	1245356	8					
19	1210160	10	57	70.3	24.7	7.96	50
	1245435	8					
23	1210201	10	69	85.1	29.9	11.83	20
	1245453	8					50
	1210202	10					20
	1245471	8					50
26	1210222	10	78	96.2	33.8	14.99	20
	1245496	8					50
	1210232	10					20
	1245574	8					50
32	1210250	10	96	118	41.6	21.99	20

### Test Requirements and Working Load Limits

Size mm	Breaking Force Min. kN	Mfg. Proof Force kN	Working Load Limit Tonnes	Mean Stress at Breaking Force N/mm <sup>2</sup> Factor 4	Mean Stress at Proof Force N/mm <sup>2</sup> Factor 2.5	Mean Stress at WLL N/mm <sup>2</sup> Factor 1
---------	------------------------	---------------------	---------------------------	--	---	---

#### Crosby KUPLEX Grade 8 Chain and Components

7	61.6	38.5	1.5	800	500	200
8	80.6	50.3	2			
10	126	78.5	3.2			
13	214	133	5.3			
16	322	201	8			
19	454	284	11.2			
23	666	415	16			
26	850	531	21.2			
32	1,290	804	31.5			

KUPLEX GRADE 8 CHAIN IS COLOUR CODED BLACK

#### Crosby KUPLEX Grade 10 Chain and Components

7	77	49	2	1,000	625	250
10	158	98	4			
13	266	166	6.7			
16	402	251	10			
19	567	354	14			
23	831	519	21			
26	1,062	664	27			
32	1,609	1,005	40			

KUPLEX GRADE 10 CHAIN IS COLOUR CODED RED

### Bend and Tensile Test as Specified in EN 818-2

Chain Dia. mm	Bend Deflection f Min. mm	Number of Samples per 200m Lot
7	5.6	2
8	6.4	2
10	8	2
13	10	2
16	13	2
19	15	1
23	18	1
26	21	1
32	26	1

Single link samples are taken from a lot size of 200m and bent to a minimum deflection f, as specified in the table above. Following removal of the force, the link is examined by a competent person. The link has to withstand the specified deflection for that diameter without any visible defects.

#### Tensile Test

Samples of chain as specified above, and in the finished condition, are subjected to a static tensile test and have to meet the minimum breaking force requirements as stated in the adjacent table, with a total ultimate elongation of not less than 20%.

#### Crosby Routine Component Sampling

All Crosby KUPLEX components are routinely verified with tensile and fatigue testing, above and beyond any current national or international standards requirement.

## MASTER LINKS

All Crosby KUPLEX components have strength characteristics that exceed those of the chain with which they are to be used.

Each Crosby KUPLEX component has a reference which relates to one of the chain sizes listed on Page 447. Where the reference includes a number, e.g., KSS 10N, the number itself refers to the chain size with which it is to be used, in this case 10mm chain. A component having a reference comprising letters only, e.g., KM-C, is a multipurpose component and in order to determine the relevant chain size it is necessary to refer to the appropriate table. All Crosby KUPLEX components are subjected to 100% non-destructive testing in accordance with BS EN 10228:1999 Part 1. Each Crosby KUPLEX component conforms in all respects with EN 1677.

### Crosby KUPLEX Master Links KM

Generous internal dimensions ensure that the KM series Master Links will fit onto a wide range of crane hooks. (For 3 and 4 leg slings, two KAL series Auxiliary Links must be attached or the KMML range utilized.)

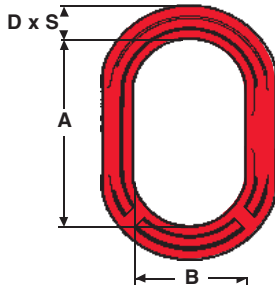

Crosby Stock No.	Reference	WLL (t)		Dimensions (mm)				Weight (kg)
		8	8+10	A	B	D	S	
2780173	KM-A	1.5	1.6	152	76	17	12	.47
2780182	KM-B	3.2	4.2	152	76	22	14	.81
2780191	KM-C	6.7	8.4	178	108	30	20	1.7
2780208	KM-D	12.8	14	228	127	40	27	4.06
2780217	KM-E	17	21.2	254	140	45	28	5.76
2780226	KM-F	24.1	30	305	171	53	36	10.56
2780235	KM-G	35.5	44	305	203	69	40	16.58
2780244	KM-HN	46	57	340	210	74	48	22.02

### Crosby KUPLEX Auxiliary Link KAL

Mechanically assembled link for three and four leg slings used in conjunction with a KM series Master Link.

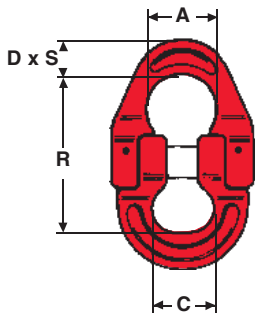

Crosby Stock No.	Reference	WLL (t)	Dimensions (mm)					Weight (kg)
			R	C	A (dia.)	D	S	
2780253	KAL7	3.2	79	31	34	17	12	.52
2780262	KAL10	6.4	110	44	46	24	17	1.74
2780271	KAL13	10.8	143	57	60	30	21	2.89
2780280	KAL16	16	187	71	76	37	26	6
2780299	KAL19	23	232	90	90	44	31	10.25

### Crosby KUPLEX Litalink KMML

A cost-effective alternative to the KM/KAL assembly for three leg and four leg slings designed for use only under the uniform load method of working load rating for general use. \* All welded construction.

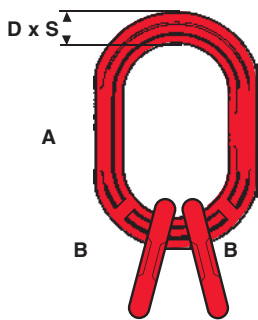

Crosby Stock No.	Reference	WLL (t)		Dimensions (mm)				Weight (kg)
		8	8+10	Link A	Link B	Section D x S	B (dia.)	
2780306	KMML7	3.2	4.2	152 x 76	63 x 34	22 x 14	13	1.15
2780315	KMML10	6.7	8.4	178 x 108	86 x 44	30 x 20	20	2.9
2780324	KMML13	12.8	14	228 x 127	113 x 70	40 x 27	26	6.18
2780333	KMML16	17	21.2	254 x 140	135 x 70	45 x 28	32.5	10.76
2780342	KMML19	23.6	30	305 x 171	155 x 85	53 x 36	38	20
2780351	KMML23	35.5	44	305 x 203	175 x 105	69 x 40	47	35
2780360	KMML26	45	57	340 x 210	220 x 135	74 x 48	55	48

### Crosby KUPLEX KM Series Usage Table



Crosby Stock No.	Reference	Single Leg		Two Leg		Three/Four Leg	
		8	8+10	8	8+10	8	8+10
2780173	KM-A	7	-	-	-	-	-
2780182	KM-B	8/10	7/10	7/8	7	7	7/8
2780191	KM-C	13	13	10	10	8/10	10
2780208	KM-D	16/19	16/19	13/16	13/16	13	13
2780217	KM-E	23	23	19	19	16	16
2780226	KM-F	26	26	23	23	19	19
2780235	KM-G	32	32	26	26	-	-
2780244	KM-HN	32	32	32	32	-	-





COMPONENTS

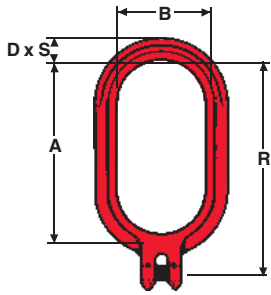

**Crosby KUPLEX Kuplink KS**

Alternative Master Link for single leg slings dispensing with the need for a Kupler.

Crosby Stock No.	Reference	WLL (t)		Dimensions (mm)					Weight (kg)
		8	8+10	A	B	R	D	S	
2780388	KS7N	1.5	2	152	76	178	17	13	.64
2780397	KS10N	3.2	4	152	76	190	22	16	1.15
2780404	KS13N	5.3	6.7	178	108	220	28	21	2.13
2780413	KS16N	8	10	228	127	285	38	27	4.69

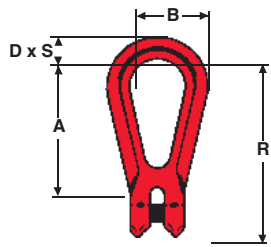

**Crosby KUPLEX Reeveable Egg Link KSS**

The ideal link for collar slings – fully reeveable and compact.

Crosby Stock No.	Reference	WLL (t)		Dimensions (mm)					Weight (kg)
		8	8+10	A	B	R	D	S	
2780422	*KSS7N	1.5	2	70	35	92	14	10	.27
2780431	KSS10N	3.2	4	102	51	132	19	14	.74
2780440	KSS13N	5.3	6.7	137	67	177	26	20	1.92
2780459	KSS16N	8	10	172	83	220	32	24	3.17
2780468	KSS19N	11.2	14	203	98	261	38	28	5.58
2780477	KSS23N	16	21	238	114	305	40	38	8.42
2780486	KSS26N	21.2	27	273	133	351	46	46	14.51

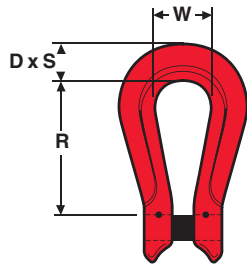

**Crosby KUPLEX Kupler K**

This component is used for joining chain to the top link.

Crosby Stock No.	Reference	WLL (t)		Dimensions (mm)				Weight (kg)
		8	8+10	R	W	D	S	
2780495	K7N	1.5	2	60	26	12	10	.15
2780501	K10N	3.2	4	73	35	19	15	.47
2780510	K13N	5.3	6.7	95	45	25	22	1.01
2780529	K16N	8	10	118	54	28	23	1.66
2780538	K19N	11.2	14	134	64	34	28	2.78
2780547	K23N	16	21	121	64	45	38	4.26
2780556	K26	21.2	27	140	82	48	45	6.30
2780574	K32	31.5	40	175	96	64	51	11.48

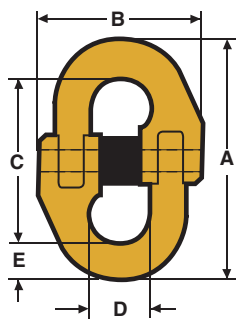

**Crosby KUPLEX Component Connector TLN**

A general purpose link for connecting chain to eye-type components. The TL is currently a Grade 8 component.

Crosby Stock No.	Reference	WLL (t)		Dimensions (mm)					Weight (kg)
		8	8+10	A	B	C	D	E	
2780583	TL7N	1.5	-	67	49	48	14.3	9	.11
2780592	TL10N	3.2	-	89	66	70	19.2	13	.36
2780609	TL13N	5.3	-	118	85	85	26.5	17	.66
2780618	TL16N	8	-	144	96	106	32	19	1.08
2780627	TL19N	11.2	-	168	115	122	38.5	23	1.77
2780636	TL23N	16	-	206	140	150	49	28	2.8
2780645	TL26N	21.2	-	230	163	166	57	32	4.4
2780654	TL32N	31.5	-	278	210	200	63	39	8.4

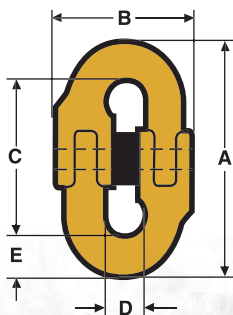

**Crosby KUPLEX Chain Connector KJ**

A flexible link for chain connection and suitable for making up endless slings. The KJ is currently a Grade 8 component.

Crosby Stock No.	Reference	WLL (t)		Dimensions (mm)					Weight (kg)
		8	8+10	A	B	C	D	E	
2780663	KJ7	1.5	-	56	34	41	8	7.5	.09
2780672	KJ10	3.2	-	73	45	51	11.5	11	.27
2780681	KJ13	5.3	-	94	61	65	14.7	14	.44
2780690	KJ16	8	-	120	75	84	19.1	18	.83
2780707	KJ19	11.2	-	142	90	100	22.9	21	1.42

CROSBY® KUPLEX®

COMPONENTS

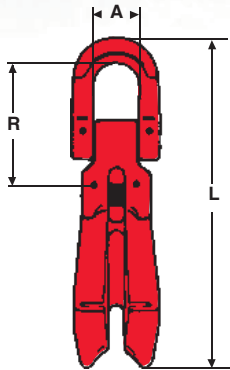

**Crosby KUPLEX Shortening Clutch KSC N**

This unique component for leg length adjustment is a major feature of the Crosby KUPLEX system. It accommodates loads of irregular shape or with a general lack of headroom and allows safe leg length adjustment of any number of legs with the load remaining fully in line.

Crosby Stock No.	Reference	WLL (t)		Dimensions (mm)			Weight (kg)
		8	8+10	L	R	A	
2780716	KSC7N	1.5	2	161	60	26	.53
2780725	KSC10N	3.2	4	211	73	36	1.28
2780734	KSC13N	5.3	6.7	272	95	46	2.7
2780743	KSC16N	8	10	360	118	56	5.26
2780752	KSC19N	11.2	14	427	134	68	9.87

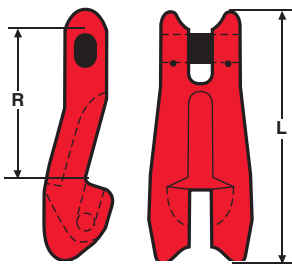

**Crosby KUPLEX Shortening Clutch KSC**

This component performs a function similar to that of the KSC N, but requires separate suspension on the master or auxiliary link using a Kupler and three links of chain.

Crosby Stock No.	Reference	WLL (t)		Dimensions (mm)		Weight (kg)
		8	8+10	L	R	
2780761	KSC7	1.5	2	98	60	.37
2780770	KSC10	3.2	4	132	84	1.00
2780789	KSC13	5.3	6.7	171	108	1.89
2780798	KSC16	8	10	213	132	3.42
2780805	KSC23	16	21	308	190	10.02
2780814	KSC26	21.2	27	360	226	15.39
2780823	KSC32	31.5	40	448	310	29

The correct use of Shortening Clutches

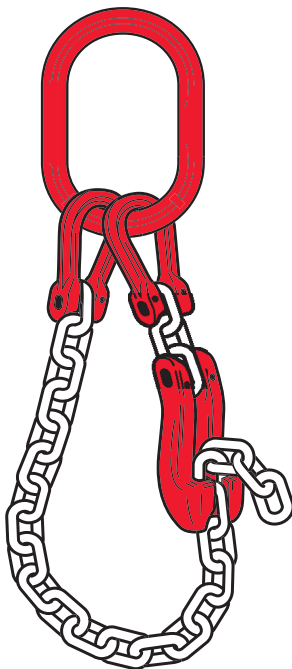

KSC Shortening Clutch in use. Basket configuration



KSC N Shortening Clutch in use.

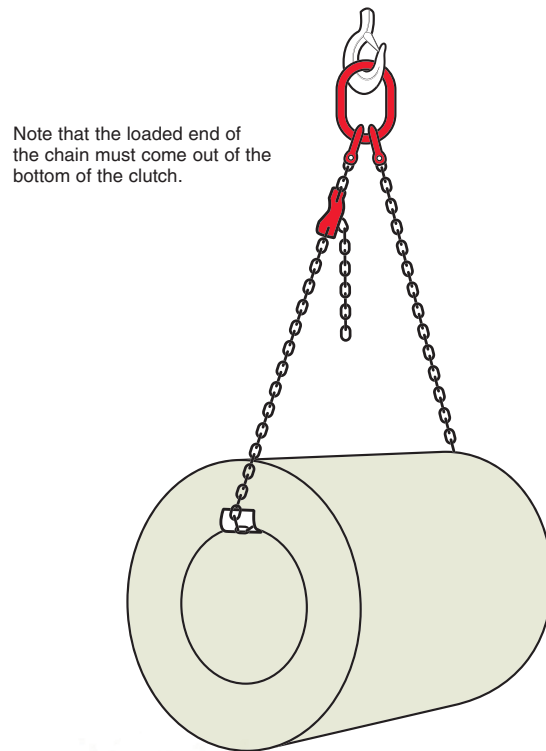

Note that the loaded end of the chain must come out of the bottom of the clutch.



COMPONENTS

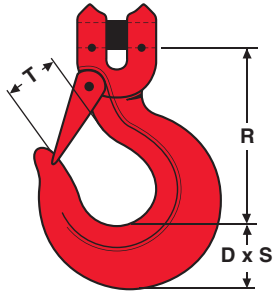

**Crosby KUPLEX Sling Hook KHN L**

This hook is most widely used in general purpose slinging.

Crosby Stock No.	Reference	WLL (t)		Dimensions (mm)					Weight (kg)	
		8	8+10	R	D	S	T		No Latch	With Latch
							No Latch	With Latch		
2780832	KHN7L	1.5	2	75	26	19	25	21.5	.37	.42
2780841	KHN10L	3.2	4	107	37	27	35	31	1.06	1.1
2780850	KHN13L	5.3	6.7	139	48	36	45	40	2.24	2.6
2780869	KHN16L	8	10	171	59	43	56	53.5	4.31	4.41
2780878	KHN19L	11.2	14	203	70	50	66	62	7.53	7.81
2780887	*KH23	16	21	222	79	51	76	60	11.39	13.14
2780896	*KH26	21.2	27	251	89	60	85	72	16.06	18.94
2780903	KHN32L	31.5	40	334	118	85	113	106	32.66	34.61

\* Supplied without a latch as standard.

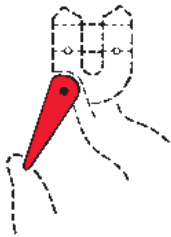

**Crosby KUPLEX Safety Latch KHL N**

A robust latch to prevent accidental detachment of the load.

Crosby Stock No.	Reference	Part Number	Hook Reference
2780912	KHL7N	2781886	KHN7
2780921	KHL10N	2781895	KHN10
2780930	KHL13N	2781902	KHN13
2780949	KHL16N	2781911	KHN16
2780958	KHL19N	2781920	KHN19
2780967	KHL32N	2781939	KHN32

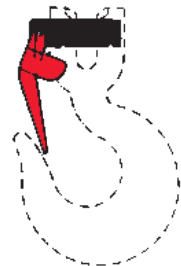

**Crosby KUPLEX Hook Latch Assembly KHL**

This assembly is for use with KH23 and KH26 and comprises a load pin to which the latch is attached.

Crosby Stock No.	Reference	Part Number	Hook Reference
2780976	KHL23	2780887	KH23
2780985	KHL26	2780896	KH26

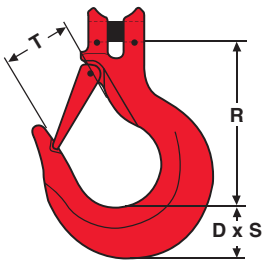

**Crosby KUPLEX Wide Bowl Hook KHW N**

This hook has a more generous throat opening and bowl than the sling hook.

Crosby Stock No.	Reference	WLL (t)		Dimensions (mm)					Weight (kg)
		8	8+10	R	D	S	T		No Latch
							No Latch	With Latch	
2780994	KHW7N	1.5	2	95	29	21	37	32	.7
2781001	KHW10N	3.2	4	130	42	30	48	44	1.9
2781010	KHW13N	5.3	6.7	168	52	38	66	59	4
2781029	KHW16N	8	10	208	65	48	79	74	7.11

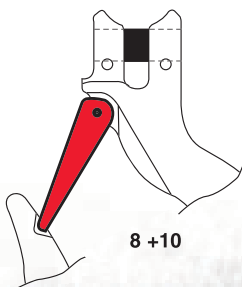

**Crosby KUPLEX Safety Latch KHW L**

This latch is designed for use on wide bowl hooks.

Crosby Stock No.	Reference	Part Number	Hook Reference
2781038	KHWL7	2780994	KHW7N
2781047	KHWL10	2781001	KHW10N
2781056	KHWL13	2781010	KHW13N
2781065	KHWL16	2781029	KHW16N



COMPONENTS

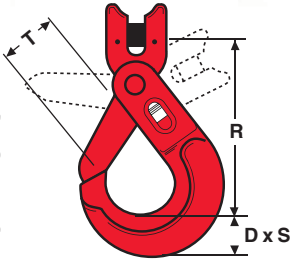

**Crosby KUPLEX Safety Hook KHX C**

All Safety Hooks in the KHX series are designed so the latch cannot open under load and requires pressure on the trigger to release the hook when the load is grounded.

Crosby Stock No.	Reference	WLL (t)		Dimensions (mm)				Weight (kg)
		8	8+10	A	B	D	S	
2781074	KHX7C	1.5	2	117	25	19	36	.82
2781083	KHX10C	3.2	4	146	32	24	47	1.51
2781092	KHX13C	5.3	6.7	181	42	30	56	3.15
2781109	KHX16C	8	10	223	49	36	70	5.27

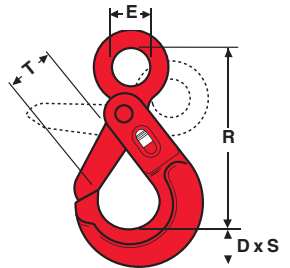

**Crosby KUPLEX Safety Hook KHX E**

A variant of the KHX C with eye instead of clevis.

Crosby Stock No.	Reference	WLL (t)		Dimensions (mm)					Weight (kg)
		8	8+10	R	D	S	T	E (dia.)	
2781118	KHX7E	1.5	2	142	25	19	36	23	.85
2781127	KHX10E	3.2	4	175	32	24	47	30	1.15
2781136	KHX13E	5.3	6.7	217	42	32	56	40	3.06
2781145	KHX16E	8	10	272	49	36	70	51	5.24
2781154	KHX19E	11.2	14	277	66	53	80	65	9.5
2781163	KHX23E	16	21	315	69	63	92	75	13.9

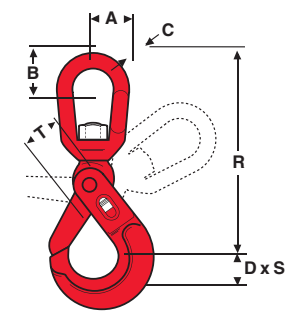

**Crosby KUPLEX Swivel Safety Hook KHX S**

Another variant incorporating bow and swivel.

Crosby Stock No.	Reference	WLL (t)		Dimensions (mm)							Weight (kg)
		8	8+10	A	B	R	D	S	T	C (dia.)	
2781172	KHX7S	1.5	2	42	42	202	25	19	36	12	1.24
2781181	KHX10S	3.2	4	50	46	235	32	24	47	15	2.11
2781190	KHX13S	5.3	6.7	60	62	293	42	30	56	19	4.28

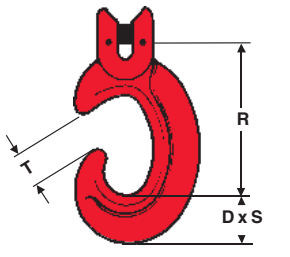

**Crosby KUPLEX C Hook KC**

The profile of this hook is designed to prevent fouling of the tip of the hook on obstructions such as scaffolding.

Crosby Stock No.	Reference	WLL (t)		Dimensions (mm)				Weight (kg)
		8	8+10	R	D	S	T	
2781207	KC7N	1.5	2	90	27	19	20	.45
2781216	KC10N	3.2	4	127	38	27	28	1.26
2781225	KC13N	5.3	6.7	165	49	36	39	2.78
2781234	KC16N	8	10	203	60	43	45	5.16
2781243	KC19N	11.2	14	242	71	52	55	8.83

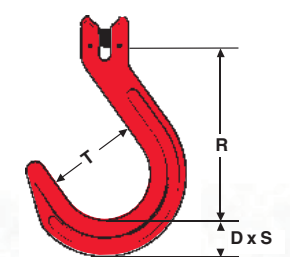

**Crosby KUPLEX Foundry Hook KF**

Designed with a wide throat to accommodate moulding box trunnions.

Crosby Stock No.	Reference	WLL (t)		Dimensions (mm)				Weight (kg)
		8	8+10	R	D	S	T	
2781252	KF7N	1.5	2	118	24	22	64	.79
2781261	KF10N	3.2	4	137	32	30	76	1.74
2781270	KF13N	5.3	6.7	165	41	38	89	3.45
2781289	KF16N	8	10	222	52	48	114	7.40
2781298	KF19N	11.2	14	248	61	56	127	11.82
2781305	KF23N	16	21	280	78	64	140	20.3



COMPONENTS

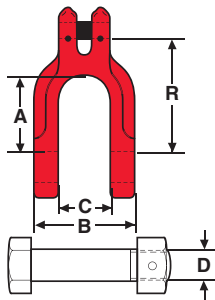

**Crosby KUPLEX Shackle KDL**

Has a wide jaw and attaches directly to the chain. Complete with bolt, hexagon nut and cotter pin.

Crosby Stock No.	Reference	WLL (t)		Dimensions (mm)					Weight (kg)
		8	8+10	A	B	C	R	D	
2781314	KDL7N	1.5	2	48	65	35	71	19	.71
2781323	KDL10N	3.2	4	74	83	44	104	22	1.36
2781332	KDL13N	5.3	6.7	98	109	57	136	29	3.02
2781341	KDL16N	8	10	122	140	73	173	35	6.18
2781350	KDL19N	11.2	14	145	162	86	203	44	10.62

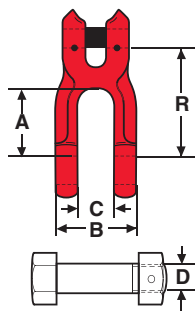

**Crosby KUPLEX Narrow Jaw Shackle KDN**

Similar to KDL series, but for applications calling for a narrower jaw.

Crosby Stock No.	Reference	WLL (t)		Dimensions (mm)					Weight (kg)
		8	8+10	A	B	C	R	D	
2781369	KDN7N	1.5	2	36	42	20	57	14	.26
2781378	KDN10N	3.2	4	53	58	28	83	20	.85
2781387	KDN13N	5.3	6.7	72	74	35	106	24	1.68
2781396	KDN16N	8	10	83	90	44	127	30	3.14

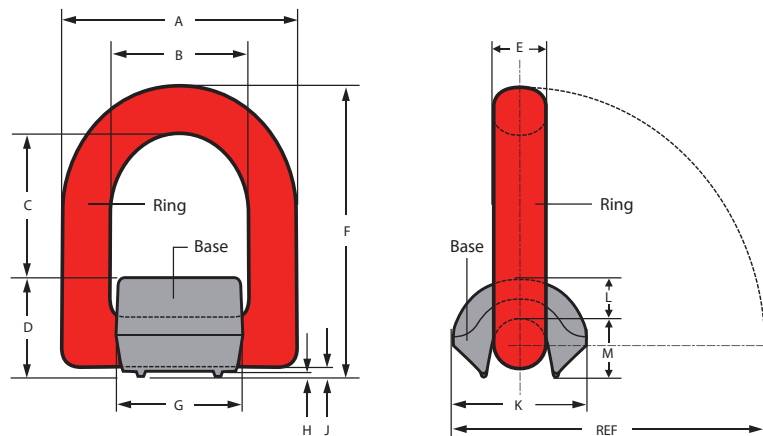

**Crosby KUPLEX KWLR Weldable Lifting Ring**

A weldable lifting ring, fully compatible with the relevant sized Kuplex 8+10 components.

Crosby Stock No.	Reference	Ring					Base mm							Weight (kg) (Ring + Base)	To Suit Normal Chain Size	
		A	B	C	R	D	F	G	H	J	K	L	M			Ref
2781403	KWLR7 (2t)	60	37	39.5	26	13	77	33	2	4	32	10	16	83	.31	7
2781412	KWLR10 (4t)	87	51	51	35	18	103	46	2	4	45	12	22	113	.83	10
2781430	KWLR13 (6.7t)	109	67	74	44	23	139	60	2	4	60	18	26	154	1.82	13
2781449	KWLR16 (10t)	117	67	68	54	27	147	60	2	4	75	23.5	30	167	2.75	16
2781458	KWLR23 (21t)	168	100	103	70	36	207	90	3	7	94	29	41	230	6.95	23

Welding advice leaflets are available on request.

**COMPONENTS**

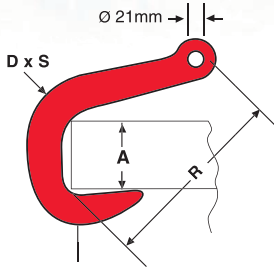

**Crosby KUPLEX Pipe Hook KPH**

For lifting pipes. Used in pairs.

Crosby Stock No.	Type/Size Reference	WLL (t)		Dimensions (mm)				Weight (kg)
		8	8+10	R	A	D	S	
2781467	KPH10	3.2	4	238	82	45	25	3.06

Note: Sling rated at minimum 30° from the vertical (60° included angle).  
MUST BE USED IN PAIRS.

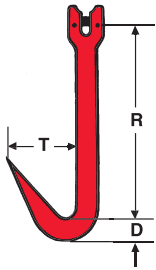

**Crosby KUPLEX Bale Hook KB**

For handling soft bales such as wood pulp, scrap paper, etc. Used in pairs.

Crosby Stock No.	Type/Size Reference	WLL (t)		Dimensions (mm)			Weight (kg)
		8	8+10	R	D	T	
2781476	KB7	1.5	2	191	22	70	.85

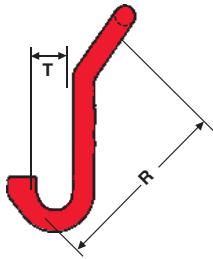

**Crosby KUPLEX Drum Hook KD**

For lifting steel drums. Used in pairs.

Crosby Stock No.	Type/Size Reference	WLL (t)		Dimensions (mm)		Weight (kg)
		8	8+10	R	A	
2781485	KD7	1.5	2	150	28	.93

Note: Sling rated at minimum 30° from the vertical (60° included angle).  
MUST BE USED IN PAIRS.

**LASHING EQUIPMENT**

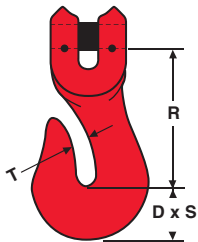

**Crosby KUPLEX Grab Hook KG**

The narrow throat is intended to engage one link of chain. The preferred use is in lashing chain and similar assemblies.

It is not suitable for slinging applications and should never be used for shortening sling legs.

Crosby Stock No.	Reference	WLL (t)		Dimensions (mm)				Weight (kg)
		8	8+10	R	D	S	T	
2781494	KG7N	1.5	2	51	22	14	9	.23
2781500	KG10N	3.2	4	79	31	17	12	.69
2781519	KG13N	5.3	6.7	102	41	22	16	1.54
2781528	KG16N	8	10	124	50	27	20	2.71

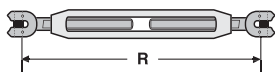

**Crosby KUPLEX Turnbuckle KTB**

For chain tensioning in load lashings and anchorages. NOT TO BE USED FOR LIFTING PURPOSES.

Crosby Stock No.	Type/Size Reference	WLL (t)		Dimensions (mm)		Weight (kg)
		8	8+10	R Min.	R Max.	
2781537	KTB10	3.2	4	375	611	2.36
2781546	KTB13	5.3	6.7	400	616	3.63





## COMPONENTS

### Sling Tags

One size tag to cover all KUPLEX slings from 7mm to 32mm.



The reverse of Grade 8  
KTS and KTP tags

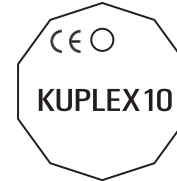

The reverse of Grade 10  
KTS10 and KTP10 tags

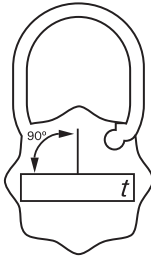

**KTS Tag**

For single leg slings  
for general service

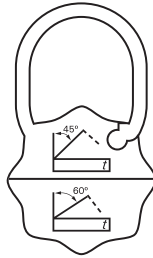

**KTP Tag**

For multi-leg slings  
for general service

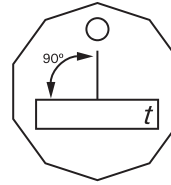

**KTS10 Tag**

For single leg slings  
for general service

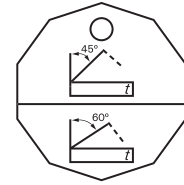

**KTP10 Tag**

For multi-leg slings  
for general service

### Skip Lifting Components

All Skip Lifting Components are designed to accommodate 13mm Crosby KUPLEX Grade 8 or Grade 10 short link alloy chain and are supplied in a zinc plated finish. All items are tested and certified in accordance with EN 818-2 and EN 1677.

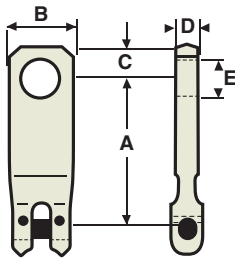

#### Top Suspension Plates

Crosby Stock No.	Type Size/Reference	WLL (t)		A	Dimensions (mm)				Weight (kg)
		8	8+10		B	C	D	E	
2781555	C151401	5.3	6.7	153	62	32	20	36	1.59
2781564	C151402	5.3	6.7	140					1.52
2781573	C151403	5.3	6.7	127					1.4
2781582	C151404	5.3	6.7	114					1.35
2781591	C151405	5.3	6.7	101					1.17
2781608	C151406	5.3	6.7	88					1.03

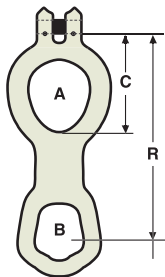

#### Keep Plate C2247

Crosby Stock No.	Type Size/Reference	WLL (t)		A	Dimensions (mm)				Weight (kg)
		8	8+10		B	C	R		
2781617	C2247	5.3	6.7	95 x 76	74 x 58	133	301	3.48	

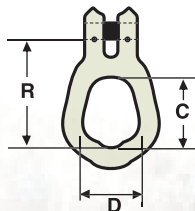

#### Single Trunnion Plate C1513

Crosby Stock No.	Type Size/Reference	WLL (t)		R	Dimensions (mm)		Weight (kg)
		8	8+10		C	D	
2781626	C1513	5.3	6.7	112	74	58	1.5

CROSBY® KUPLEX®

**Limitations on Use**

Due to risk of embrittlement, Crosby KUPLEX slings should not be used in acid or caustic solutions nor in heavily acidic or caustic-laden atmospheres. In uncertain conditions consult your distributor.

Crosby KUPLEX slings must not be heat-treated, galvanised, plated, coated or subject to any process involving heating or pickling. Each of these processes can have dangerous effects and will invalidate the manufacturer's certificate.

Crosby KUPLEX slings may be used at temperatures down to -40°C with no reduction in the working load limit. The use of Crosby KUPLEX chain slings within the permissible temperature range in the tables shown does not require any permanent reduction in working load limit when the chain sling is returned to normal temperatures. A sling accidentally exposed to temperatures in excess of the maximum permissible should be withdrawn from service immediately and returned to the distributor for thorough examination.

Sling Temperature	Reduction in Working Load Limit	
	Grade 8	Grade 10
-40°C to 200°C	None	None
200°C to 300°C	10%	DO NOT USE
300°C to 400°C	25%	
Above 400°C	DO NOT USE	

When using Crosby KUPLEX slings in exceptionally hazardous conditions, the degree of hazard should be assessed by a competent person and the working load limit adjusted accordingly. Examples include the lifting of persons and lifting of potentially dangerous loads such as molten metals, corrosive materials or fissile material and certain offshore activities.

**Before First Use**

No sling should be put into use until a valid Test Certificate has been supplied.

Check that the sling is precisely as ordered and all chain and components are marked 'KUPLEX' or 'CGK'.

Check that all identification references and working load limits marked on the sling correspond with the information on the sling Manufacturer's Certificate.

**Before Each Use**

Before each use a Crosby KUPLEX sling should be subject to inspection with a visual check on the condition of the chain sling to identify obvious damage or deterioration which might affect its fitness for use. Withdraw the sling from service if in any doubt.

**In Use**

Never exceed the working load limit (WLL) marked on the sling.

Strictly observe the marked restriction on the angle of the sling legs.

Take into consideration the cumulative effect of de-rating depending on the method of slinging to ensure that the chain sling selected has a working load limit (WLL) equal to or greater than the mass to be lifted.

Ensure that the master link articulates freely on the hook of the crane or other lifting appliance.

The crane hook should be positioned over the centre of gravity of the load and the sling rigged from that point, using shortening clutches for leg adjustment where necessary.

Make sure that the load is free to move and is not bolted or held down in any way. Check also that there are no obstacles to making the lift.

Do not leave a suspended load unattended.

When a chain is used in choke hitch, i.e. with the sling legs passed around the load and hooked or linked back onto the chain, the working load limit (WLL) of the chain sling should be no more than 80% of that marked.

The working load limits stated in EN 818-4 have been determined on the basis that the loading of the chain sling is symmetrical.

This is when the sling legs are symmetrically (i.e. equally) disposed in plan and all have the same angle to the vertical. For unequally loaded Crosby KUPLEX chain slings the lift should be referred to a competent person to establish a safe rating for the chain sling. Alternatively in the case of asymmetric loading, the chain sling should be rated at half the marked WLL.

ATLAS LIFTING EQUIPMENT LTD.			
MANUFACTURER'S CERTIFICATE & EC DECLARATION OF CONFORMITY. LIFTING ACCESSORIES		REFERENCE NO: CMF16863	
MANUFACTURED BY: ATLAS LIFTING EQUIPMENT LTD. TITAN WORKS PROMETHEUS STREET LINCOLN LN1 2NS		SUPPLIED TO: SAMSON CASTINGS PROVIDENCE WORKS LOWER GORNA WEST MIDLANDS DY3 9LL	
QTY	DESCRIPTION	IDENTIFICATION NUMBER	WLL
1	KUPLEX GRADE 8 10MM W/O LEG CHAIN SLING FITTED WITH SHORTENING CLUTCHES AND TERMINATING END WITH KHX10C SAFETY HOOKS REACH 3 MTR  COMPONENTS PARTS 1 x KM-C - P2Y246 2 x KSC10N - P5Y246 2 x KHX10C - P1Y213 2 x 2.6 MTRS 10MM KUPLEX 10030RPC GRADE 8 CHAIN - 242967 HARMONISED STANDARD BS EN 818-4	KCS8184	4.25 TONNES 0-45°
ON BEHALF OF THE ABOVE FIRM		DECLARATION OF CONFORMITY	
SIGNED		ON BEHALF OF THE FIRM ABOVE I DECLARE THAT THE PRODUCT DESCRIBED HAS BEEN CONSTRUCTED IN ACCORDANCE WITH THE NAMED STANDARD AND CONFORMS TO ESSENTIAL HEALTH AND SAFETY REQUIREMENTS OF THE MACHINERY DIRECTIVE 2006/42/EC	
DATE			

An instruction leaflet 'Safe Use of Crosby KUPLEX Chain Slings' should be supplied with each new sling.

Enter details of sling in the register of lifting equipment.

Ensure that personnel who are to use the Crosby KUPLEX sling have received appropriate instruction and training.



## Maintenance

### Inspection

Crosby KUPLEX chain slings should be checked before each period of use and the sling withdrawn from service and referred to a competent person if any of the following are observed:

- Distortion of the links, connectors or hooks
- Stretch in any link of the chain links
- Wear in the chain, especially between adjoining links. The mean diameter at any point should be no less than 90% of the nominal chain diameter. SEE TABLE BELOW

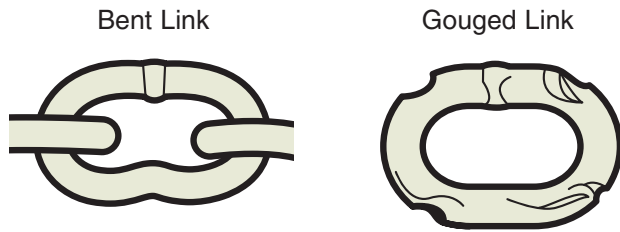

- Cuts, nicks, gouges, cracks, excessive corrosion, heat discolouration or any other defects
- Signs of any increase in the throat opening of hooks. This should not exceed 10% of the nominal value or be such as to allow the safety latch, if fitted, to become disengaged.

### Thorough Examination

It is a requirement of the European Standards for Grade 8 chain slings that a thorough examination should be carried out by a competent person at intervals not exceeding twelve months. This maximum interval may be less where legal requirements differ throughout the European Union. For example, in the UK the majority of industry sectors apply a maximum interval of six months.

- Where slings are in constant use, or the conditions of use are severe, it is advisable to carry out more regular inspections.
- Never attempt on-site repair of Crosby KUPLEX slings.
- Your Crosby KUPLEX distributor will carry out the examination and any necessary repair, and provide a suitable record for you to enter in your register of lifting equipment.

## Limits of Allowable Wear in Crosby KUPLEX Grade 8 and 10 Chains

If it were possible to define allowable wear in precise and simple terms, there would be less need to employ skilled and experienced examiners. The fact is that the decisions as to what is allowable and what is not can be highly subjective and need to take into account a variety of conditions and circumstances. The most common form of wear is that which occurs at the internal inter-link locations and, in order to detect this condition, it is necessary to manipulate the links in such a way as to allow examination and measurement at these points. It should be noted that in the chain in

Nominal Diameter (mm)	Minimum Mean Diameter (mm) $\leq \frac{d_1 + d_2}{2}$
7	6.3
8	7.2
10	9
13	11.7
16	14.4
19	17.1
23	20.7
26	23.4
32	28.8

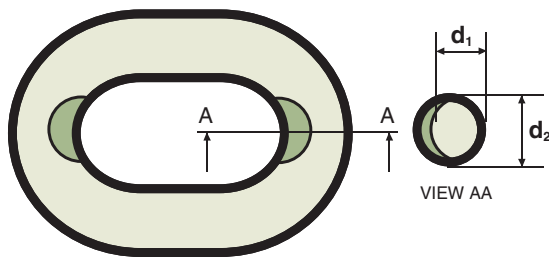

new condition, there may have been some flattening of the material at the link intrados due to contact with the forming mandrel and it is standard practice to determine the diameter of the material in the chain as new by taking the mean of two measurements at right angles in the same plane as  $d_1$  and  $d_2$ .

## Legal Requirements

### Supply

All new Crosby KUPLEX chain slings supplied within EU Member States fully comply with the essential health and safety requirements of the Machinery Safety Directive 2006/42/EC. Each country is bound to implement this directive with national legislation, e.g., in the United Kingdom the applicable regulations are the Supply of Machinery Regulations 1998.

### Use

Once a Crosby KUPLEX sling has been first put into service within an EU Member State, different EU Directives apply to its subsequent use.

These are the Use of Work Equipment Directive (98/655/EEC) and its amending Directives 95/63/EC. Member States were bound to implement this directive with national regulations by 5th December 1998. In the United Kingdom these are the Lifting Operations and Lifting Equipment Regulations (LOLER) which are part of the Provision & Use of Work Equipment Regulations (PUWER) relevant to lifting equipment.



## SAFE SLINGING

The safe and competent use of lifting gear cannot be adequately learned from a manual. A good slinger learns his trade only after practical training and lengthy experience. However, this section establishes some sound basic principles and highlights some of the major malpractices which must be avoided.

### 1. Evaluating the Load

The user should take all practicable steps to establish the weight of any load. An intelligent guess is not good enough. A drawing may be available giving the weight or it may be calculable within reasonable limits of accuracy. In the case of multi-piece loads (e.g., a bundle of steel rods) one item may be weighed in order to calculate the total weight of the load. If it is likely that the load may have to be lifted again, the weight should be clearly marked on it.

### 2. Tip Lifting of Hooks

All KUPLEX hooks are designed to support the load in the bowl. Users should ensure that the hook of a sling engages freely in the lifting point so that the weight of the load is supported in the bowl of the hook.

Wedging or forcing the hook tip into the lifting points results in the hook being stressed in a manner for which it was not designed which may easily lead to hook deformation and premature failure.

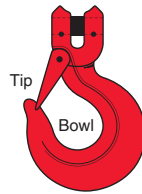

### 3. Misuse of Shortening Clutches

KUPLEX Shortening Clutches can be misused. Ensure that the chain carrying the load always leads out of the bottom of the clutch as illustrated. If the direction is reversed so that the load-carrying chain leads out of the top of the clutch, this can result in the front portion of the clutch being pulled off and the load released.

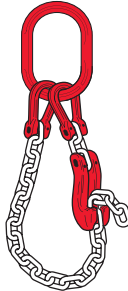

### 4. Knotting, Twisting and Transverse Bending of Chain

Chain is designed to support a load in a straight line with the line of force running through the crowns of each link. Chain that is twisted, or even worse knotted, cannot develop its full strength and will almost certainly fail prematurely. Users should remove twists from a chain leg before lifting and should NEVER knot a chain. If it is necessary to shorten a chain, a KUPLEX Shortening Clutch should be used. Similarly, chain that is bent under tension across a sharp corner is stressed in a manner for which it is not designed. The user should use timber (or any other suitable material) packing pieces to reduce the severity of this type of stressing.

### 5. Battening Down

It is sometimes believed that slings in choke hitch can be made more secure by striking the hook, link or adjacent chain in an attempt to force the bight into closer contact with the load. This malpractice is often known as 'battening down' and is dangerous. The bight should be allowed to assume its natural angle which will be about 120°.

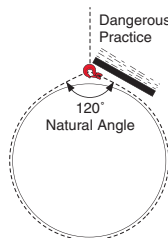

### 6. Load Stability

Good slingers will develop the habit of assessing unusual loads and estimating the centre of gravity and then attaching the sling in such a manner that the centre of gravity is below the lifting points, or if this is impossible, well within them. If there is the slightest doubt of the stability of a load, it should be slowly lifted just clear of the ground. If the load tilts, the sling should be refixed in a more stable position.

### 7. Slingers Duty of Self Protection

Slingers should wear suitable protective clothing. At the moment when the strain is taken on a sling, the slinger's hands and feet should be clear of the load and he should then position himself so that he does not risk injury if the load were to fail.

### 8. Shock Loading

Crane drivers, particularly, and slingers should be aware of the dangers of shock loading. Shock loads may break a chain even though the weight of the load being lifted is well below the working load limit for that chain. High acceleration forces, or shock loads, may be caused by the sudden operation of the crane, by not taking up slack before starting to lift, or by the sudden impact of falling loads. Crane drivers should always lift and lower slowly.

### 9. Tag Lines

When lifting long loads, particularly in confined spaces, slingers should attach a rope or 'tag line' to one or both ends of the load so that rotational movement may be controlled.

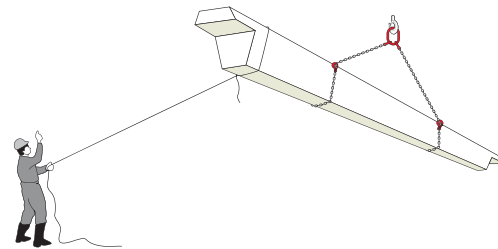

### 10. Code of Signals

Slingers and crane drivers should use an approved Code of Signals before lifting operations are commenced. There should be an agreement between the crane driver and the slingers that one slinger only is in charge of a lift, and only he will give signals. The crane driver should ignore signals from all other personnel except the EMERGENCY STOP signal which may be given by anyone present and must always be acted upon.

### 11. Landing of Load

Before a load is lifted, a place should be prepared where it is to be put down. The nature of the load will determine the type of preparation necessary but most loads should be lowered onto timber battens. The sling may then be easily withdrawn. The load should never be landed directly on to the chain.

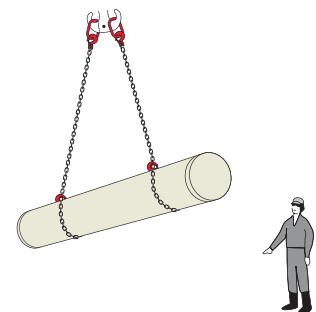

### 12. Hooking Back Unused Legs

In the case of multi-leg slings with not all legs in use, the unused legs should be hooked back by engaging the hook in the master link or the master assembly. Similarly, after finishing a lift, if the sling is to remain on the crane hook, all hooks should be hooked back into the master link or the master assembly.

### 13. Sling Stowage

When lifting operations are finished, slings should be removed from crane hooks and stowed on a properly designed rack. They should not be left lying on the floor where they may suffer damage or may be lost.

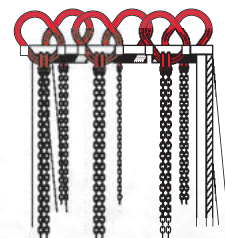



## CHAIN SLINGS

### Restrictions on the angle of use

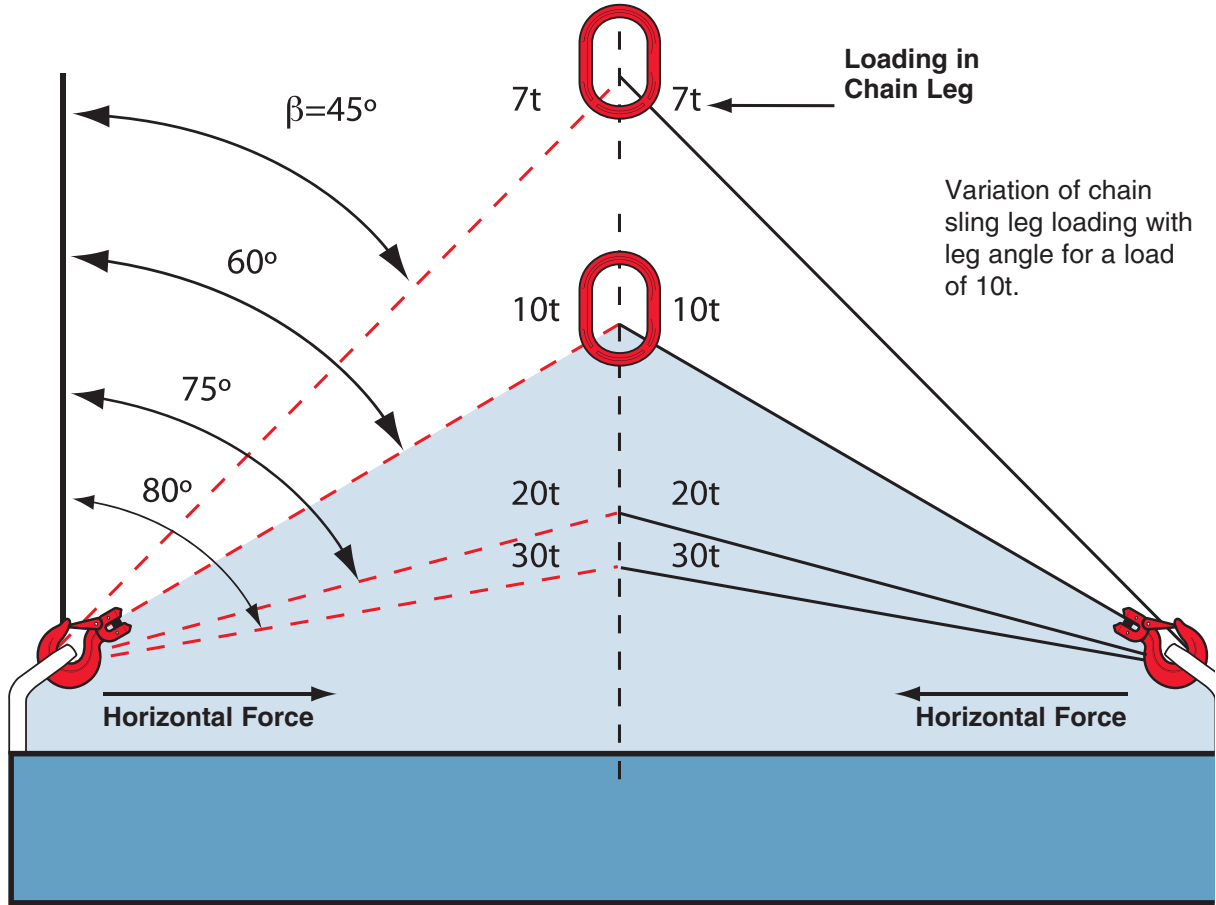

All multi-leg chain slings exert a horizontal component of force, which increases as the included angle becomes greater.

No chain sling should be used if the angle from the vertical exceeds  $60^\circ$ , as beyond this point the forces in the legs drastically increase.

**DO NOT USE MULTI-LEG CHAIN SLINGS AT ANGLES WITHIN THE SHADED AREA.**

Angles of less than  $15^\circ$  should also be avoided as these can lead to the load becoming unstable.

#### Further Advice and Information

For further advice on any lifting problems, consult first with your Crosby KUPLEX distributor, who is fully qualified to advise on all aspects of lifting, as well as providing all the necessary equipment and services.

All the advice and information contained in this publication is in line with recognised European and International Standards and Codes of Practice.

A Code of Practice for the Safe Use of Lifting Equipment is available from the Lifting Equipment Engineers Association.



Lifting Equipment Engineers Association  
3, Osprey Court, Kingfisher Way, Hinchingsbrooke  
Business Park, Huntingdon, Cambs. PE29 6FN UK  
Telephone: + 44 (0) 1480 432801

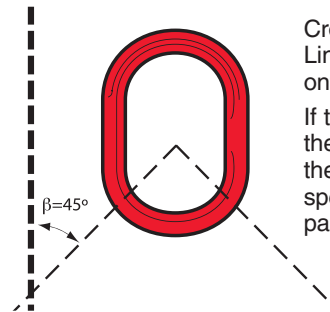

Crosby KUPLEX 8+10 Master Links have an angle guide forged onto them.

If the sling angles are on or inside the guidelines the sling is within the angle range  $0^\circ < \beta \leq 45^\circ$ , as specified in the load chart on page 441.

#### Further References

- BS EN 818 Parts 1, 2, 4 and 6 Short Link Chain for Lifting Purposes - Safety
- BS EN 1677 Components for Slings - Safety
- BS 6166 Part 3 Lifting Slings Guide to Selection and Safe Use
- ISO 3056 Use and Maintenance of Non-calibrated Lifting Chain and Chain Slings
- ISO 7593 Chain Slings Assembled by Methods Other Than Welding - Grade T(8)
- ISO 8539 Forged Steel Lifting Components for use with Grade T(8) Chain
- ISO 12480-1 Planning and Management of Lifting Operations and Safe Systems of Working

## SPECIAL APPLICATIONS

This section deals with more complicated lifting problems and slightly more advanced techniques in dealing with them.

### 1. Out-of-Balance Loads

Some loads are asymmetrical and, therefore, do not balance about their centre point and require more careful handling. It is essential for the slinger to acquire the skill of estimating the position of the centre of gravity and then to place the crane hook immediately above this estimated point.

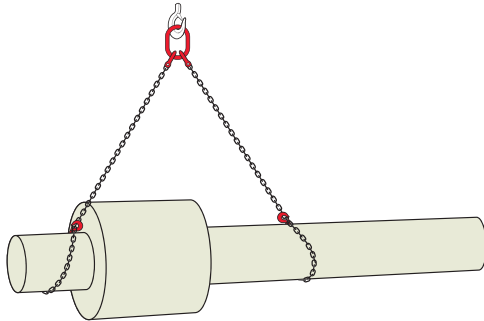

If the shape of the load permits it, the sling should be positioned equidistant about the centre of gravity ensuring a safe horizontal lift.

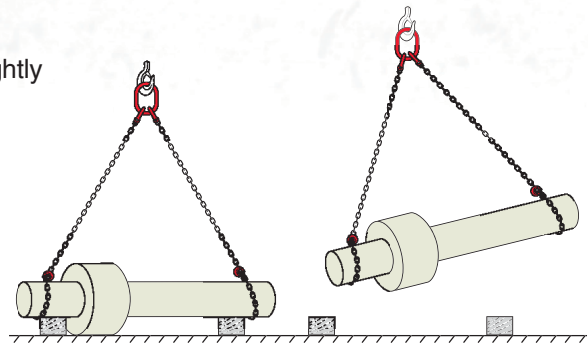

If an out-of-balance load is fitted with a sling attached in such a manner that the crane hook is not immediately above the centre of gravity, the load will tilt until the centre of gravity is directly beneath the crane hook. In this case, the sling leg nearer the heavy end will be withstanding a greater force than the leg at the lighter end. This situation could become progressively more extreme until one leg is supporting virtually all the load whilst the second leg is acting merely as a steadying leg.

It is impossible to give precise guidance since loads come in an infinite variety of shapes and sizes but the slinger should be aware that when handling an out-of-balance, tilted load the leg at the heavier end could be supporting anything up to 100% of the weight and in extreme cases a sling should be selected which is capable of safely supporting the whole load on one of its legs.

### 2. Clamping Force

Multi-leg slings impact a 'clamping force' or a compressive force on the load which increases as the included angle is increased. This force is also much increased in the type of sling where the hooks are threaded on a loop chain.

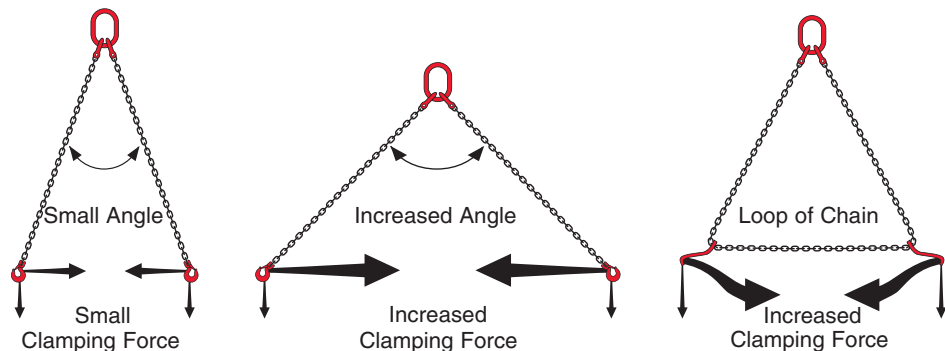

The slinger should be aware of this force so that he may use it to his advantage and avoid the dangers which it might cause. For example, with this shape of load, the clamping force is used to good effect in ensuring that the hooks are clamped tightly against the load. A minimum of 60° included angle is required (30° to vertical).

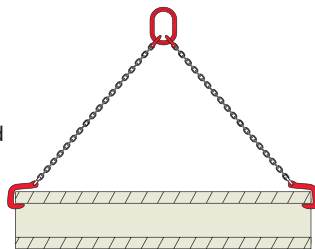

Cases have occurred where the load has not been rigid enough to withstand the clamping pressure. Slingers should be aware of this danger and take steps to reduce the clamping force in the case of crushable loads, e.g., lightweight frames.

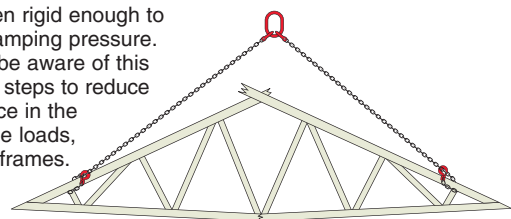

### 3. Combination Slings

Concrete beams, steel joists, etc. can be lifted with a two-leg sling in choke hitch but if the work is repetitive, it is better to use two short reeveable collar slings in conjunction with a two leg sling as illustrated. The reeveable collar slings are more convenient to maneuver under the load and are cheaper to replace when worn.

When using combination slings the reeveable collar slings must have the same size of chain as the multi-leg sling used in combination with them. In the case illustrated right, therefore, the complete combination should be rated as a two leg sling in choke hitch.

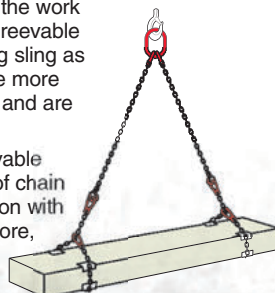

Large packing cases, bundles of steel sheets and similarly shaped loads can be handled by a double basket sling. But a more convenient alternative is a four leg sling used in combination with two reeveable collar slings as illustrated. For rating purposes, this combination can be regarded as a double basket sling provided, as always, all slings in the combination are of the same chain size.

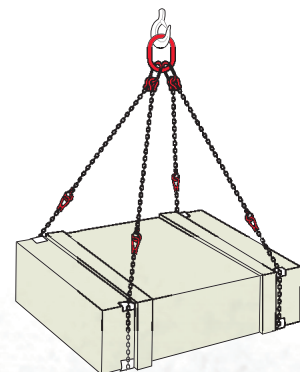





## METHODS OF SLINGING

### Single Leg Slings

#### 1. Straight lift

**WLL:** Under normal conditions the WLL will be the WLL for single leg slings.

**Comment:** A suitable method of lifting an effectively balanced load from a single lifting point.

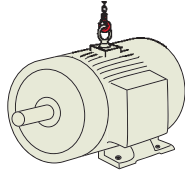

#### 2. Choke lift

**WLL:** The WLL should be no more than 75% of the WLL for single leg slings.

**Comment:** This method forms a loop which tightens as the load is lifted. Do NOT attempt to force the bight into closer contact with the load. Allow the chain to assume its natural angle. Single leg slings in choke hitch are not suitable for lifting long loads which might tilt or for any load which is not effectively balanced in the single loop.

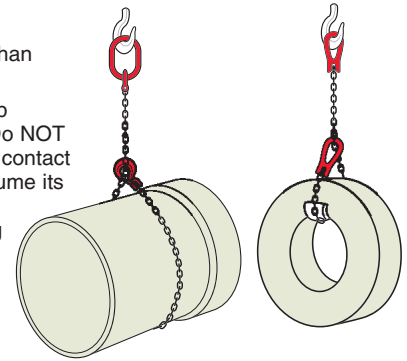

### Single Leg Slings in Basket Hitch

#### 1. Single leg in basket hitch (back hooked into top link)

**WLL:** Under normal conditions the WLL will be the WLL for single leg slings.

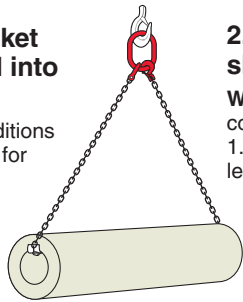

**Comment:** A single leg sling, back hooked to form a basket hitch, assumes the appearance of a two leg sling but it should never be rated as such. It should be noted that the master link is only designed for single leg loading and, therefore, the single leg WLL should never be exceeded. The included angle should not be allowed to exceed 90°.

#### 2. Reeveable collar sling in basket hitch

**WLL:** Under normal conditions the WLL will be 1.41 x the WLL for single leg slings.

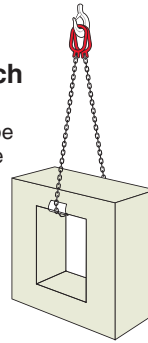

**Comment:** The included angle should not be allowed to exceed 90°.

#### 3. Single adjustable basket sling

**WLL:** Under normal conditions the WLL will be the WLL for single leg slings.

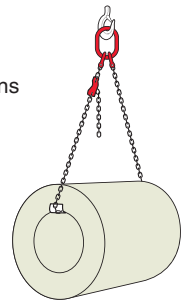

**Comment:** It would be advisable to fit a master link suitable for two leg rating in spite of the single leg rating of this type of sling. The included angle must not be allowed to exceed 120°.

If a 2 leg masterlink is used and the sling is a controlled angle of maximum 90° included the 2 leg rating can apply.

### Endless Slings

#### 1. Choked endless

**WLL:** Under normal conditions the WLL will be the WLL for endless slings.

**Comment:** There is no need to de-rate in this instance by virtue of the choked configuration.

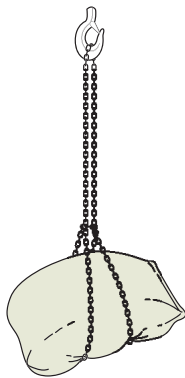

#### 2. Double endless

**WLL:** Under normal conditions the WLL will be the WLL for endless slings.

**Comment:** The maximum included angle between diagonally opposite legs should not exceed 90°.

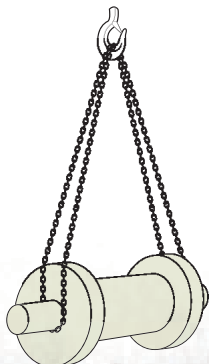

### Two Single Leg Slings Used Together

#### 1. Two single legs in straight lift

**WLL:** Rate as a two leg sling. The WLL will, therefore, be the same as an equivalent two leg sling.

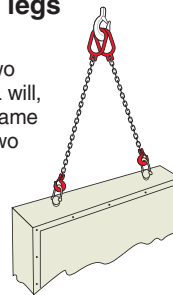

#### 2. Two single legs in choke hitch

**WLL:** The WLL should be the WLL for the equivalent reeved sling.

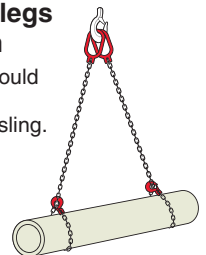

#### 3. Two single legs in basket hitch

**WLL:** Rate as a two leg sling. The WLL should be no more than that applicable to an equivalent two leg sling.

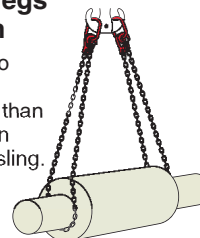

**Comment:** Two single leg slings should not be used together to form a pair unless:

- They are of the same type, grade, size and length.
- They are both marked with the same WLL.
- The included angle between the two legs does not exceed 120° (measured between diagonally opposite legs in example 3).
- The crane hook is large enough to comfortably accept both upper terminal fittings of the slings.

## METHODS OF SLINGING

### Two Leg Slings

#### 1. Straight lift

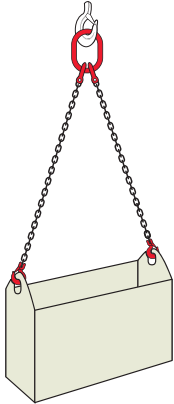

**WLL:** Under normal conditions the WLL will be the WLL for a two leg sling.

#### 2. Choke hitch



**WLL:** The WLL should be no more than 80% of the WLL for a two leg reeved sling.

#### 3. Basket hitch

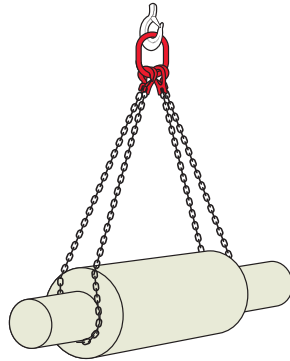

**WLL:** Rate as a two leg sling. The angle of any leg should not exceed 45° from the vertical.

#### 4. Drum sling

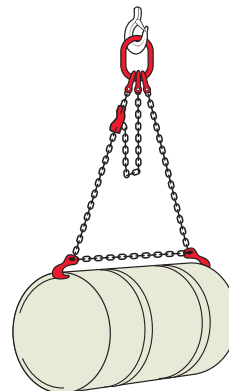

**WLL:** Should be rated as a single leg sling.

#### 5. Two leg sling – with only one leg in use

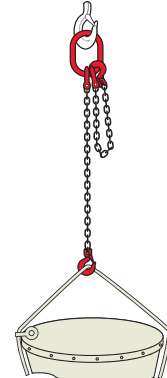

**WLL:** Rate at half the working load marked on the sling. The WLL should be no more than 80% if used in choke hitch.

**Comment:** In example 3, basket hitch - the sling assumes the appearance of a four leg sling but it should be noted that the master link will be designed for two leg loads only and the sling should, therefore, be rated as a two leg.

**Comment:** In example 4, drum sling - in this configuration the included angle should be maintained as close as possible to 60° (30° from vertical).

If, therefore, drums of different lengths are lifted, a Crosby KUPLEX Shortening Clutch should be fitted so that the length of chain can be adjusted to maintain this angle.

**Comment:** In example 5, two leg sling with only one leg in use, ensure the unused leg is hooked back out of harm's way.

### Three Leg Slings

#### 1. Straight lift

**WLL:** Under normal conditions the WLL will be the WLL for three leg slings.

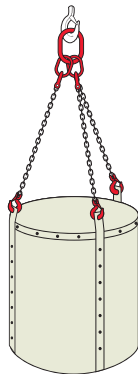

#### 2. Choke hitch

**WLL:** The WLL should be no more than 80% of the WLL for a four leg sling.

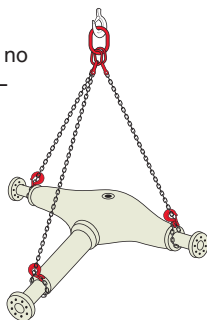

**Comment:** Rate as indicated only in cases where the load appears to be reasonably equally distributed between all three legs. If two are obviously supporting most of the load, rate at 2/3 of the marked working load.

### Four Leg Slings

#### 1. Straight lift

**WLL:** under normal conditions the WLL will be the WLL for four leg slings.

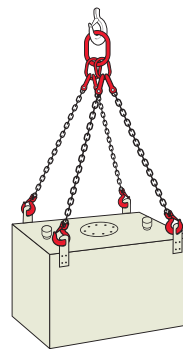

#### 3. Double basket sling

**WLL:** Rated as two leg sling.

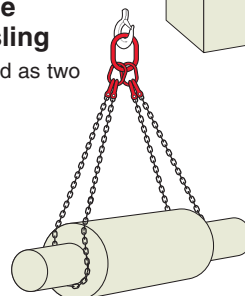

**Comment:** This WLL applies to double basket slings designed as such and fitted with a KUPLEX Master Assembly strong enough for this duty. It does not apply to a back-hooked two leg sling. The maximum included angle should be 90° measured between diagonally opposite legs, or maximum 45° from vertical.

#### 2. Choke hitch

**WLL:** The WLL should be no more than 80% of the WLL for a four leg sling.

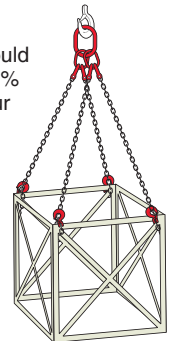

#### 4. Two, two leg slings used as four leg

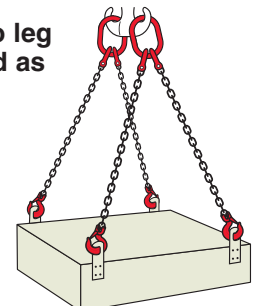

**WLL:** The WLL should be no more than that applicable to an equivalent four leg sling.

**Comment:** Refer to comments on page 461 for slings used in pairs.



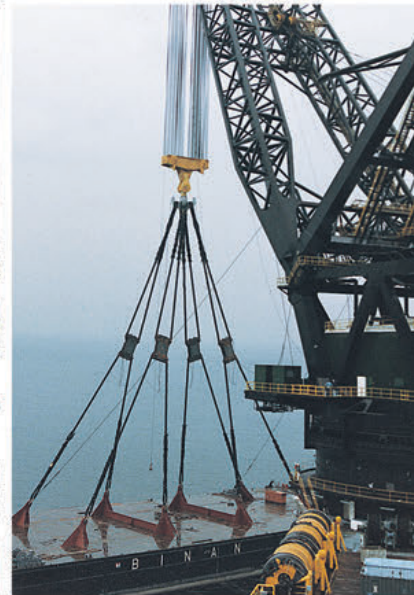

# SPECIAL PRODUCTS



# CROSBY... A NAME THAT ENCOMPASSES YEARS OF ENGINEERING AND MAUFACTURING EXCELLENCE



High capacity crane barge

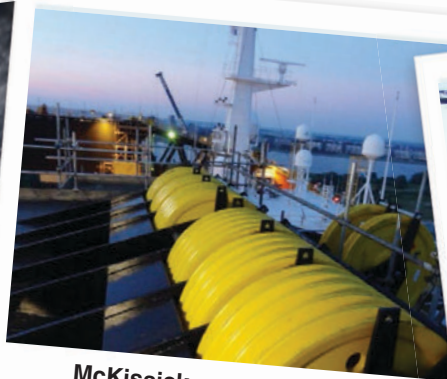

McKissick supplied the sheaves for the original vessel



Barge's 7,000 ton cranes updated with McKissick sheaves

Those who know the name “Crosby” need no introduction to the significance this name holds within the rigging and lifting industry. It is a name that encompasses years of engineering and manufacturing excellence—a legacy founded on the principle of quality without compromise.

The Thialf, from Heerema Marine Contractors, is the largest crane ship in the world and Heerema’s main deepwater construction vessel (DCV). The Thialf was initially equipped with Crosby® McKissick® sheaves in 1985. In 2014, Heerema Marine Contractors started to refurbish the Thialf crane sheaves. Due to the proven product quality, value-added services and unmatched training that Crosby offers, the Thialf again used Crosby McKissick sheaves to extend its life-time for another 20 years.

While Crosby is a household name for many those who have yet to discover the meaning behind the name need only a brief history to realize that the global achievements associated with Crosby products is a standard of quality, and innovation over the course of the past century.



# THE ABILITY TO PROVIDE CUSTOM DESIGNED PRODUCTS HAS ALWAYS BEEN A STRENGTH OF CROSBY



**Sheaves used in the locks  
of the Panama Canal**



**Sheaves used to move  
vessels and gates**

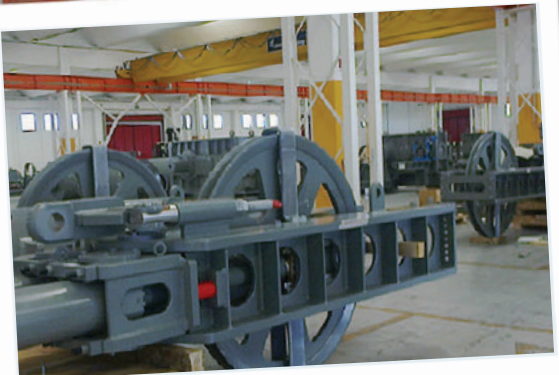

**Roll Forge sheaves produce  
remarkable performances**

---

Whether your need is for a variation of an “off the shelf” item, or for a “special engineered design” product, Crosby is your source.

The Panama Canal Authority commissioned Crosby to supply several 64.37in./1635mm diameter roll-forged sheaves for a project as part of the Panama Canal Enlargement known as ‘The Third Set of Locks Project’. The sheaves are lighter, stronger and more wear-resistant due to our proprietary upset roll-forged process.

By combining the experience of our technical support team, our research and development team, our engineering team and our manufacturing team, we are capable of designing and fabricating custom designed products for any special application.

---



## MANUFACTURING INNOVATIVE PRODUCTS SINCE 1885



Crosby® Engine Hook



McKissick® Fairleader Base



McKissick® 500 Ton Bridge Crane Block with Duplex Hook



Crosby® 18 Ton Sorting Hook

---

When you choose Crosby, you choose a trusted partner who is committed to providing you the resources you need to operate with confidence and without compromise.

Since 1885, Crosby's first product that has stood the test of time is the Red-U-Bolt®. It is still one of the most recognizable products in the material handling industry. Today Crosby continues this legacy by delivering a diverse portfolio of products engineered to exceed the toughest demands of any industry, including land-based / offshore energy, subsea, transportation cargo handling and cell towers.

Crosby's product design team will provide your company with innovative, marketable, and manufacture-ready industrial design solutions for your next product. For more information call: 1(800)775-1555.

---





## GLOSSARY OF TERMS FOR TESTING AND THIRD PARTY CERTIFICATION

### **American Bureau of Shipping - (ABS)**

American Bureau of Shipping is a third party certification agency. ABS publishes several guidelines for various lifting applications. Some of the most common “lifting” guidelines include the following:

- *Guide for Certification of Cranes*
- *Requirements for Certification of Construction and Survey of Cargo Gear on Merchant Vessels*
- *Guide for the Certification of Drilling Systems*

(This is not intended to be a complete list of guidelines published by ABS.)

A common request is for ABS third party witness of proof test and magnetic particle inspection after proof test. Depending on the type of certification, requirements may include design review, materials testing, non destructive testing, proof load and special packaging.

When specifying ABS certification, it is necessary to know to which guideline the product is to be certified (i.e., Guide for Certification of Cranes, etc.).

### **Det Norske Veritas - (DNV)**

Det Norske Veritas is an independent foundation established in 1864 for safeguarding life, property and the environment. Along with inspection and advisory services, DNV provides the following three types of certification services.

**Classification** - Certification based on DNV Rules or Certification Notes.

**Statutory Certification** - Certification under authority granted by national authorities (i.e., NPD, UK-HSE, Canada, Australia, etc.) according to acts, regulations, statutory instruments given by statutory authorities.

**Conformity Certification** - Certification to client specifications, national standards or recognized codes. Some of the most common DNV certification rules for lifting are:

- *Rules for Certification of Lifting Appliances*
- *Certification Notes No. 2.7-1 Offshore Containers*
- *Rules for Classification of Mobile Offshore Units Part 6, Chapter 5.*

(This is not intended to be a complete list of DNV Rules.)

Lifting products may require design review, materials testing, non destructive testing, DNV issued Proof Test Certificate (CG3) and DNV issued Certificate of Conformity (C of C).

Type approved products with a Manufacturer’s Survey Agreement (MSA), require all the above except: Design Review, DNV issued Proof Test Certificate (CG3) and DNV issued Certificate of Conformity (C of C). For products certified to 2.7-1 Specification (Offshore Containers), DNV witnesses proof test and issues their Proof Test Certificate (CG3) and Certificate of Conformity (C of C) to the distributor responsible for building the container set. It is the distributor’s responsibility and cost to contact DNV.

When specifying DNV certification, always specify one of the three types of services and, if it is a DNV Rule, which Rule is applicable (i.e., Rules for Certification of Lifting Appliances, etc.).

### **American Petroleum Institute - (API)**

Established in 1919, API writes specifications that are published as aids for the procurement of standardized equipment and materials, as well as instructions to manufacturers of equipment or materials covered by an API specification. Some of the common specifications written by API for “Lifting” are:

- *Specification for Drilling and Production Hoisting Equipment (API Spec 8C)*
- *Specification for Offshore Cranes (API Spec 2C)*
- *Specification for Wire Rope (API 9 Spec A)*
- *Specification for Quality Programs (API Spec Q1)*

A standard to which a manufacturer’s quality system must comply in order to state that products are manufactured to API requirements, resulting in permission to apply the API monogram.

When specifying API, it is necessary to know to which API Specifications the product is to be certified (i.e., Specification for Drilling and Production Hoisting Equipment (API Spec 8C), etc.).

### **Lloyd’s Register of Shipping**

A society established in 1760 and recognized under UK laws to provide third party assurance of compliance to plans, specifications, rules, codes and fitness of use by approving designs, surveys and reports. Lloyd’s Register acts on behalf of clients and governments to verify products conform to statutory requirements and provides inspection and advisory services to clients.

Some of the most commonly used Lloyd’s Register certification types include the following:

- *Code for Lifting Appliances in a Marine Environment*
- *Rules and Regulations for the Classification of Ships*
- *Rules and Regulations for the Classification of Mobile Offshore Units*
- *Container Certification Scheme*

## GLOSSARY OF TERMS FOR TESTING AND THIRD PARTY CERTIFICATION

### Lloyd's Register of Shipping continued

A common request is for Lloyd's Register witness proof test and magnetic particle inspection with certification. However, certification may require design review, material tests or product verification to statutory or customer requirements.

**When specifying Lloyd's Register of Shipping certification, know the code, standard, statute or customer requirement (i.e., Code for Lifting Appliances in a Marine Environment, etc.).**

### Federal Specifications & Military Standards

The Federal Specifications & Military Standards' documents specify dimensional, performance and test requirements for products. Some specifications define particular testing that is not normally performed on standard items. Crosby products, when identified in the latest Crosby General Catalog, will meet the requirements when tested by the party awarded the government contract. Certification is usually covered by a Crosby Standard Certificate of Conformance.

### ISO 9001

A standard defining a manufacturer's or service organization's Quality Management System requiring third party certification. ISO 9001, the most comprehensive ISO certification level, involves the design, development, production and shipping of products. ISO 9001 requires that all procedures, work instructions, processes and additional activities be documented.

Attainment of ISO 9001 forms the basis for meeting other world standards and provides customers with documented proof of Crosby's ability to consistently provide product quality and performance.

### National Association of Chain Manufacturers (NACM)

A U.S. Standard specifying dimensional and performance criteria for graded chain.

### American Society for Testing and Materials (ASTM)

American Society for Testing and Materials, established in 1898, is the largest voluntary standards development system in the world. ASTM Standards cover:

**Inspection Methods (Certificates Required)** — i.e., Magnetic Particle, Ultrasonic, Dye Penetrant, X-Ray, Hardness, etc.

**Processes (Standard Certificate of Conformance)** — i.e., Hot Dip Galvanizing, Electroplate, Mechanical Galvanizing, etc.

**Material Properties (Tensile Test Report Required)** — i.e., Specification for Steel Forging, Carbon and Alloy for General Industrial Use (A668), Specification for Steel, Closed-Impression Die Forgings for General Industrial Use (A521), etc.

**Material Test Methods** — Covers Tensile and Charpy impact test specimens and test methods, i.e., Test Methods of Tension Testing of Metallic Materials (E8), A370 Test Methods and Definitions for Mechanical Testing of Steel Products (A370), etc.

### American National Standards Institute (ANSI)

American National Standards Institute established in 1916 develops product specific performance standards for items such as cranes, hooks, slings, screw threads, etc., usually covered with a standard Certificate of Conformance.

## Crosby Standard Testing Upon Request

\***Crosby Proof Test with Third Party Witness** — Receive load test certification signed, documented and serial number traceable to these agencies: ABS, DNV, Lloyds, B.V., RINA, Germanischer Lloyd, etc.

\***Crosby Proof Test with I.L.O. Certificates** — Standard load test performed and documented on International Labor Organization Form 4 (I.L.O. Form 4). Certified and traceable by serial number. The certificates are maintained at Crosby.

\***Crosby Standard Certificate of Conformance** — Part number, description, date and statement of conformity to Crosby literature available at time of manufacture.

\***Crosby Magnetic Particle Inspection with Certification** — ASTM E-709 wet or dry method standard at Crosby. Customer can require other types. Certified and traceable to serial number.

\***Crosby Ultrasonic Inspection with Certification** — ASTM A-609 for castings, ASTM A-388 for forging standard at Crosby. Customer can require other types. Certified and traceable to serial number.

\***Crosby X-Ray with Certification** — Customer provides x-ray technique and level of acceptance.

\***Crosby Dye Penetrant Inspection with Certification** — A liquid penetrant examination to ASTM E-165. Other types of Dye Penetrant certification is available at time of order. Certified and traceable to serial number.

\***Crosby Material Tensile Test with Certification** — Tensile test performed per ASTM A370. Test report documents Tensile Strength, Yield Strength, Elongation, and Reduction of Area.

\***Crosby Material Chemical with Certification** — Chemical certification provided by steel mill or foundry. Traceable to heat number, heat letters and PIC code.

\***Crosby Charpy Impact Test with Certification** — Impact Test per ASTM A370 or ASTM E8 at temperature, location, and energy absorbed requirement as defined by customer or applicable specification.

\*A charge will be applied. Crosby certification is available when requested at time of order.

The items listed above are for standard certification. Additional certification is available and must be requested at time of order.



## CROSBY CUSTOM MACHINED SHANK HOOK & NUT QUOTATION REQUEST FORM

Company Name:		Date:
Address:	City, State, Zip	
Phone:	Fax:	Country:
Customer Contact Name:		
Quotation Due Date:	Product Delivery Date:	
Crosby / McKissick Proposal Number:		Quantity:

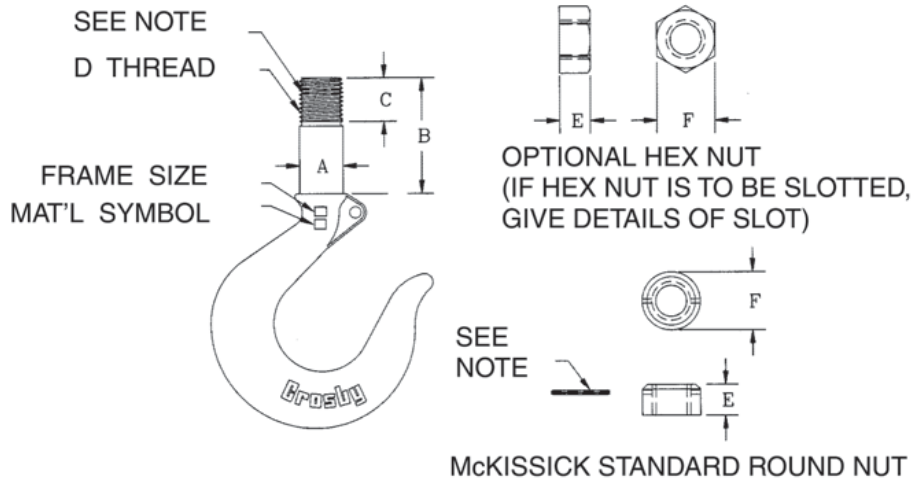

**NOTE:**  
FOR INSTALLATION OF SPRING PIN, STANDARD PRACTICE  
IS TO FIELD DRILL NUT AND SHANK AFTER ASSEMBLY  
AND ADJUSTED TAKE-UP IS MADE.

**Dimensions:**

Frame Size and material Symbol:

Working Load Limit (tons)

A.	Round or Hex Nut
B.	E.*
C.*	F.
D.	
	<b>Hook Latch Kit</b>
	_____ SS-4055 Flipper latch
	_____ PL Flapper latch
	_____ 4320 Latch

\* The minimum thread length engaged in the nut should not be less than one (1) thread diameter.

For additional information concerning customer design products, contact:  
**In U.S.A.** - Crosby's Special Engineered Products Group at 1-800-777-1555  
**In Canada** - Crosby Canada at (905) 451-9261  
**In Europe** - N.V. Crosby Europe at 32-15-757125 (26)



Company Name:		Date:
Address:		City, State, Zip Code:
Phone:	Fax:	Country:
Customer Contact Name:	Quantity:	Requested Delivery Date:
<b>- INTERNAL USE ONLY -</b> Crosby / McKissick Proposal Number:		

Crosby McKissick patented (U.S. Patent 7,000,905 and 7,293,763) Split-Nut® Hook Retention System featured on McKissick® crane blocks makes inspection easier. The hook can be disassembled, inspected and put back into service in a fraction of the time of a conventional threaded nut.

Available Configurations									
319 Hook Type and Working Load Limit 4:1 Alloy (t)	Crosby Hook ID Code	"A" Available Shank Dia.		"B" Dimension		"C" Dimension		"D" Maximum Grip Length	
		(in.)	(mm)	(in.)	(mm)	(in.)	(mm)	(in.)	(mm)
15	L	1.75	44.4	1.62	41.1	3.25	82.5	5.38	137
22	N	2.00	50.8	1.62	41.1	3.50	88.9	5.38	137
30	O	2.50	63.5	2.31	58.7	4.38	111	15.69	398
37	P	2.50	63.5	2.31	58.7	4.38	111	21.69	551
45	S	3.00	76.2	2.75	69.9	5.50	140	21.25	540
60	T	3.00	76.2	2.75	69.9	5.50	140	23.25	591
75	U	4.00	102	3.75	95.2	7.50	190	19.25	489
100	W	4.00	102	3.75	95.2	7.50	190	17.25	438

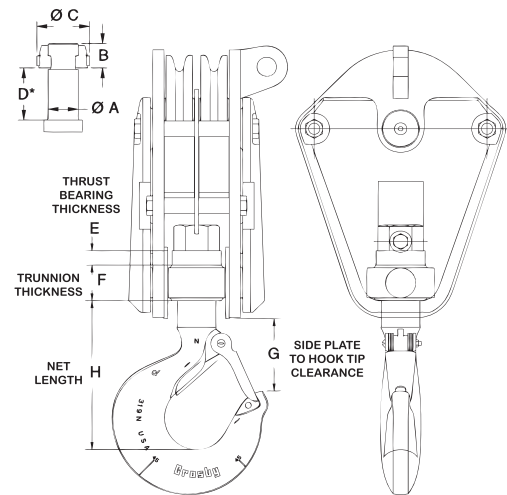

### Steps to fit your block with the patented McKissick Split-Nut® Hook Retention System

1. Measure side plate to hook tip clearance and record in box "G" below. (The net length "H" dimension may be affected by holding the "G" dimension. If there is adequate clearance at tip of hook, the net length "H" dimension may be the dimension to specify).
2. Remove hook and thrust bearing from existing crane block.
3. Measure shank diameter and record in box "A" below.
4. Measure nut thickness and record in box "B" below. The standard "B" dimension (shown above) is a minimum and will be utilized unless actual measured "B" dimension is required.
5. Measure nut diameter and record in box "C" below. The standard "C" dimension (shown above) is a minimum and will be utilized.
6. Measure thrust bearing thickness and record in box "E" below. If known, record thrust bearing manufacturer and stock number below.
7. Measure trunnion thickness through the hook shank hole and record in box "F" within 1/32".
8. The required grip length "D" will be the addition of the "E" and "F" dimensions plus 0.06" for running clearance.
9. Determine the required hook size based on shank diameter and tonnage. Other shank /hook / tonnage combinations may be available. Your supplied information will be reviewed for the Split-Nut application.
10. Complete the form and forward to your local Authorized Distributor for quotation.

Thrust Bearing Standard							
Shank Ø		Bearing Outside Dia.		Bearing Thickness		Bearing Description	
(in.)	(mm)	(in.)	(mm)	(in.)	(mm)		
1.75	44.4	3.266	83.0	0.938	23.8	T-176	
2.00	50.8	3.672	93.3	1.062	26.9	T-202	
2.50	63.5	4.375	111	1.063	27.0	T-251	
3.00	76.2	5.250	133	1.313	33.4	T-301-W	
4.00	102	7.000	178	1.750	44.4	40-TP-114	

### Required Dimensions

Frame Code or other distinguishable size designator:		Material Type: <b>Check One:</b> <input type="checkbox"/> Carbon <input type="checkbox"/> Alloy	
Working Load Limit: <b>Check One:</b> <input type="checkbox"/> Tons <input type="checkbox"/> Metric Tonnes		Thrust Bearing Identification:	
Check One:		Check One:	
Dimension A: <input type="checkbox"/> (in.) <input type="checkbox"/> (mm)	Dimension E: <input type="checkbox"/> (in.) <input type="checkbox"/> (mm)	<b>Hook Latch Kit Check One:</b> <input type="checkbox"/> SS-4055 Flipper latch <input type="checkbox"/> PL / PL-N Flapper latch <input type="checkbox"/> S-4320 Latch  <b>For personnel hoisting applications, only a PL, PL-N or S-4320 shall be utilized.</b>	
Dimension B: <input type="checkbox"/> (in.) <input type="checkbox"/> (mm)	Dimension F: <input type="checkbox"/> (in.) <input type="checkbox"/> (mm)		
Dimension C: <input type="checkbox"/> (in.) <input type="checkbox"/> (mm)	Dimension G: <input type="checkbox"/> (in.) <input type="checkbox"/> (mm)		
Dimension D*: <input type="checkbox"/> (in.) <input type="checkbox"/> (mm)	Dimension H: <input type="checkbox"/> (in.) <input type="checkbox"/> (mm)		

\*D = Bearing Thickness "E" + Trunnion Thickness "F" + .06" running clearance.

For additional information concerning customer design products, contact:  
**U.S.A.** - Crosby's Special Engineered Products Group at 1-800-777-1555  
**Canada** - Crosby Canada at (905) 451-9261  
**Europe** - N.V. Crosby Europe at 32-15-757125 (26)



## McKISSICK® DUPLEX HOOK ASSEMBLIES

- Cast alloy steel.
- Available in forged steel upon special request.
- **Can be machined to optional dimensions upon request.**
- Furnished complete with two flipper latches.
- The working load limits shown are in short tons (T) and applicable for loading up to an included sling angle of 90 degrees. For included sling angles up to 60 degrees, the hooks can be rated in metric tons (t).

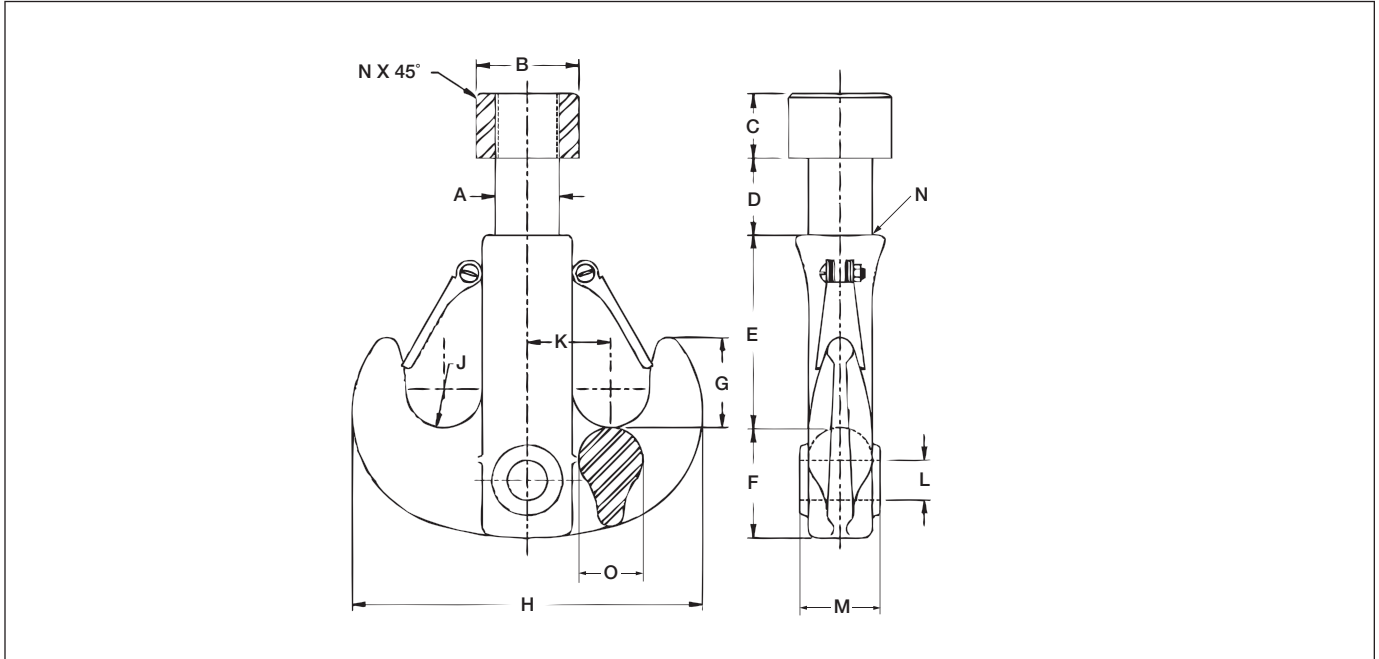

Duplex Hook with Nut and Latches Dimensions (in.)																	
Stock No. Hook Assembly	Size (Tons)	A	B	C	D	E	F	G	H	J	K	L	M	N	O	Weight Each (lbs.)	Replacement Latch Kit Stock No.
127384	25	2.50	4.00	2.50	3.00	7.50	4.31	3.50	13.75	1.50	3.25	2.06	2.75	.12	2.50	62	1090143
126802	50	3.00	4.88	3.00	3.25	10.00	5.50	5.00	18.50	2.00	4.25	2.81	3.75	.25	3.50	136	1090189
137373	75	4.00	7.50	4.00	4.00	13.50	8.00	6.50	25.00	2.50	5.50	3.31	4.62	.25	4.50	311	1090223
137364	100	5.00	9.00	5.00	5.50	16.00	9.00	9.00	30.00	3.00	6.75	3.81	5.00	.25	5.00	532	1090223
137266	125	5.00	9.00	5.00	5.50	19.00	10.00	9.00	31.50	3.00	7.50	4.31	5.25	.25	5.00	844	1090223
137355	150	6.00	10.00	6.00	6.00	19.00	10.00	9.00	31.50	3.00	7.50	4.31	5.25	.12	5.00	844	1090223
137346	200	7.00	12.00	6.00	8.25	20.50	12.75	10.50	36.50	3.50	8.00	4.81	6.75	.25	6.00	1085	1090241
137337	250	8.00	14.00	7.00	9.00	23.75	14.00	11.75	40.00	3.75	8.75	5.12	8.00	.25	7.00	1635	1090241
137328	350	8.00	15.50	8.00	10.00	24.00	16.00	12.00	45.25	4.25	10.25	7.16	9.50	.25	9.00	2423	143080
2022897	500	10.00	18.00	8.25	16.75	26.50	18.50	12.25	45.00	4.50	10.00	7.16	9.50	.25	9.00	3300	8022575*
137319	600	10.00	18.00	8.25	8.75	25.00	18.00	14.00	51.00	5.00	11.00	7.94	9.75	.25	9.00	3120	143071
+2031520	1000	12.00	23.00	10.00	22.00	36.50	28.75	16.00	69.50	4.50	17.00	10.75	14.50	—	11.50	7800	8015361*

Ultimate Load is 4 times the Working Load Limit.

\* Bolt style latch.

+ 1000 ton has different prong profile than shown.

For the purpose of calculating D/d ratio, utilize dimension O.

For additional information concerning custom design products, contact:

In U.S.A. — Crosby's Special Engineered Products Group at 1-800-777-1555, Fax (918) 834-5035.

In Canada — Crosby Canada at (905) 451-9261.

In Europe — N.V. Crosby Europe at 32 15 757125 (26).

## HOOK DATA FORM

Hook Size:	Name of Person Completing Form:
Sales Order:	
Working Load Limit (Tons)	Telephone:
Hoist Name and Model:	Distributor:
Top Hook <input type="checkbox"/> Bottom Hook <input type="checkbox"/>	Distributor P.O.:
Is Self-Closing Gate Required? Yes <input type="checkbox"/> No <input type="checkbox"/>	Accurate dimensions are important. If you have any questions, contact your authorized Crosby Distributor.

### Shank Length

1. Measure total USABLE shank length from top of hook shank to top of gate assembly. Gate assembly is not considered part of the USABLE shank. When measuring other manufacturers' hooks, measure from the top of the hook shank to the hook shoulder.
2. Measure threaded portion (enter BLANK if threads not required). NOTE: Hook is supplied with Steel Hex-Load Nut and Bronze Load Washer. Hook and Nut threads are National Coarse. If a SPECIAL Load Nut or Load Washer is required, attach a drawing to this form.

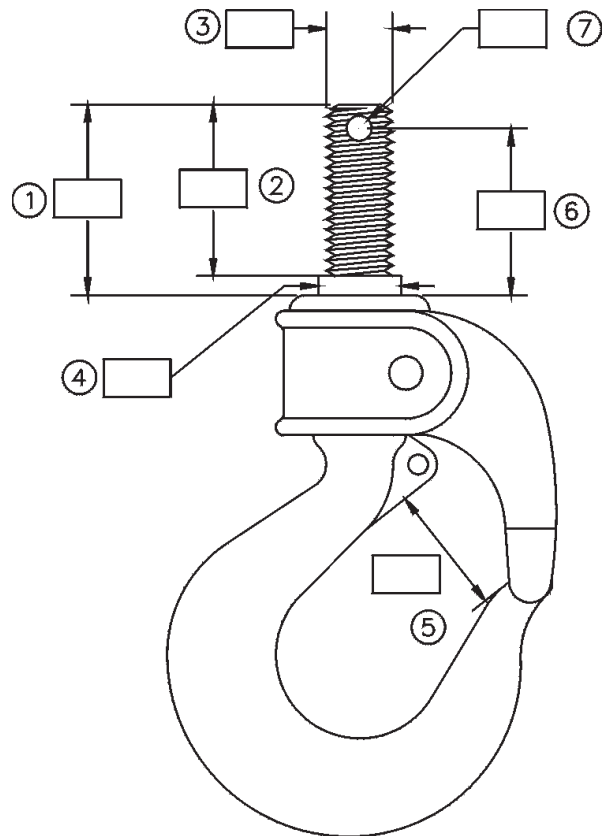

### Shank Diameter

3. Measure width of threaded portion.
4. Measure width of blank portion.

### Throat Opening

5. ONLY measure throat opening if this distance is critical to customer's operation.

### Cross Hole in Shank Hooks

(complete only if required)

6. Measure shank length from center of hole to top of gate assembly.
7. Measure diameter of hole.

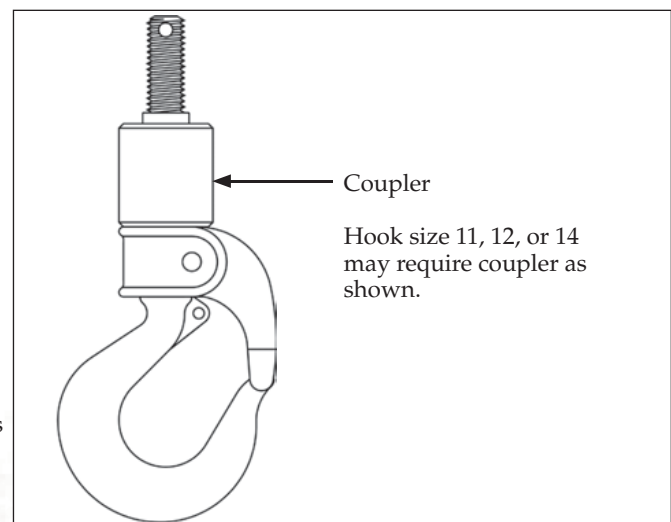
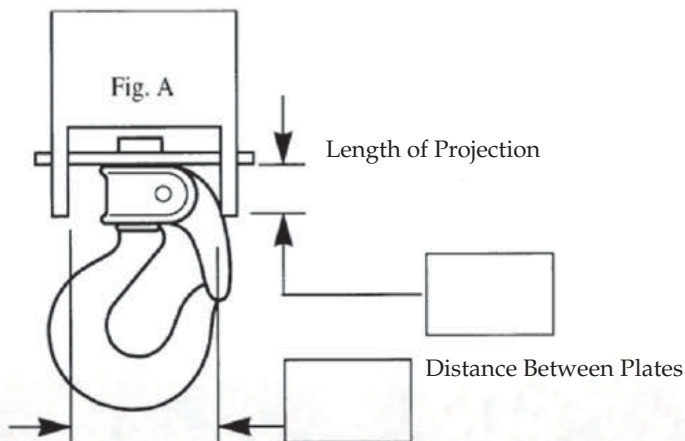





## SPECIFICATION SHEET FOR CROSBY HR125, HR125M, HR1000 HOIST RINGS WITH OPTIONAL BOLT LENGTHS

Date:	
CG #:	Crosby Quote Number:
Customer #:	Contact:
Distributor's Name:	Distributor's Fax Number:
Distributor's Phone Number:	Quantity Requested:
Distributor's P.O. #	Crosby Representative:

- Determine the *Type of Threads* required on the Hoist Ring - Metric or UNC, UNF, etc. **NOTE - NOT DESIGNED FOR PIPE, ACME OR TAPERED THREADS.**
- Determine the *Working Load Limit* of the requested Hoist Ring.
- Determine *Bolt Diameter* - The diameter of the required bolt.
- Determine *Effective Thread Length* - This is the length the threads must be in order to fully engage, or project through, the work piece. **NOTE; If the Effective Thread Length is not known, the Length of Bolt is required.**
- Determine *Length of the Bolt* - The overall length of the bolt as measured from under the head of the bolt. **NOTE: If the Effective Thread Length is not known, the Length of the bolt is required.**
- # of Thread Threads per Inch (Length Between Threads for Metric threads)* - This information is required to ensure we ship proper bolt size (i.e., 1/2 - 13, 7/8 - 9, 8 x 1.25, etc.).

1. → **Thread Type** (Circle One)

UNC Thread  
Metric Thread  
Other  
**(NOT DESIGNED FOR PIPE, ACME, OR TAPERED THREADS)**
2. → Hoist Ring Capacity  
(Working Load Limit)

\_\_\_\_\_ lbs./kgs

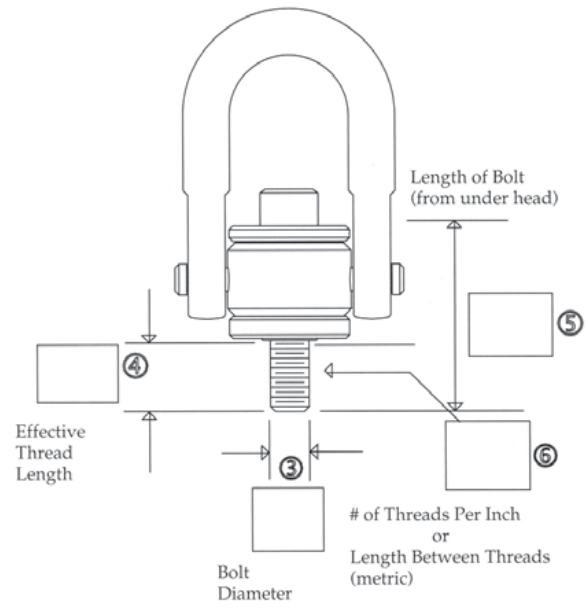

**SPECIAL PRODUCTS**

Company Name:	Country:	Date:
Address:	City:	State, Zip:
Phone:	Fax:	Country:
Customer Contact Name:		Quantity:

**SHEAVE INFORMATION**

Sheave Diameter: \_\_\_\_\_  
 Wire Rope Size: \_\_\_\_\_  
 Number of Sheaves: \_\_\_\_\_

**BEARING TYPE**

Bronze Bushing       Roller Bearing  
 Tapered Roller Bearing    Other

**BLOCK INFORMATION**

Style:  Vertical    Horizontal  
 Dimensions: A. \_\_\_\_\_ B. \_\_\_\_\_ C. \_\_\_\_\_ D. \_\_\_\_\_

**APPLICATION INFORMATION**

Line Speed: \_\_\_\_\_      Single Line Pull: \_\_\_\_\_      Degree of Wrap: \_\_\_\_\_  
 Environment: \_\_\_\_\_

**FREQUENCY OF USE**

Continuous: \_\_\_\_\_      Intermittent: \_\_\_\_\_      One Time: \_\_\_\_\_

**SPECIAL REQUIREMENTS**

Special Testing: \_\_\_\_\_  
 Finish: \_\_\_\_\_  
 Third Party Inspection / Approval:  
 (If 3rd Party Inspection or Approval is required, please refer to page 475-476.)

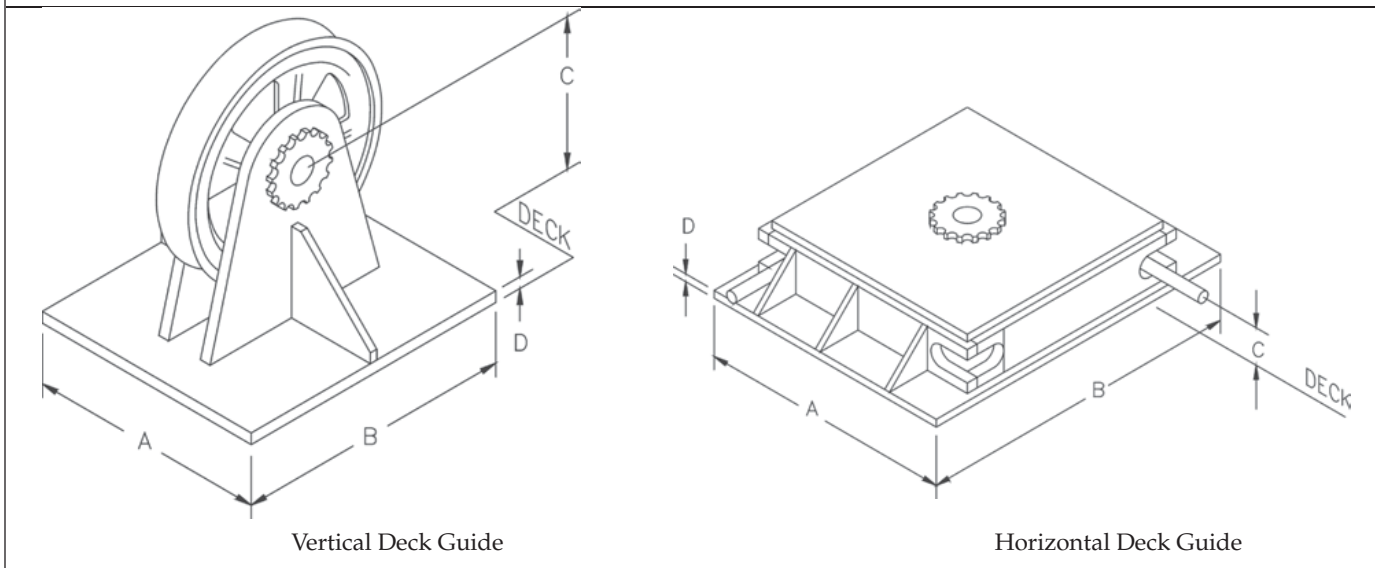



Company Name:	Country:	Date:
Address:	City:	State, Zip:
Phone:	Fax:	E-Mail:
Customer Contact Name:		Quantity:

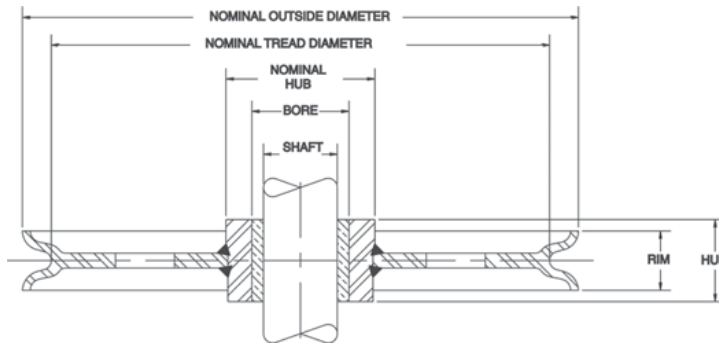

**DIMENSIONAL INFORMATION**

Nominal Outside Diameter: \_\_\_\_\_ Wire Rope Size: \_\_\_\_\_ Rim Width: \_\_\_\_\_

+ Shaft Size: \_\_\_\_\_ \* Hub Width: \_\_\_\_\_

Nominal Tread Diameter (Optional): \_\_\_\_\_ Nominal Hub Diameter (Optional): \_\_\_\_\_

+ Shaft size is bore size on Plain Bore Sheaves.  
\* Hub width is measured over the cone of the Tapered Bearing Sheaves.

**BEARING TYPE**

- Bronze Bushing
- Tapered Roller Bearing
- Roller Bearing (requires hardened and ground shaft)
- Full Complement Double-Row Cylindrical
- Roller Bearings with Seals
- Ball Bearing
- Finish / Plain Bore
- Underwater
- Other

**MATERIAL TYPE**

- Roll Forged (Flame hardened 14" (356mm) and larger)
- Cast Steel
- Fabricated
- Forged Steel
- Domed
- Other

**APPLICATION INFORMATION**

Line Pull: \_\_\_\_\_ Fleet Angle: \_\_\_\_\_ Degree of Wrap: \_\_\_\_\_

Line Speed: \_\_\_\_\_ Environment: \_\_\_\_\_ Groove Angle: \_\_\_\_\_

**SPECIAL REQUIREMENTS**

Special Testing: \_\_\_\_\_

Finish: \_\_\_\_\_

Third Party Inspection / Approval: \_\_\_\_\_

(If 3rd party inspection or approval is required, please contact Crosby Customer Service.)

**NOTE: Crosby manufactures sheaves in a wide array of styles and sizes. See page 277-304.**

**SPECIAL PRODUCTS**



Company Name:	Country:	Date:
Address:	City:	State, Zip:
Phone:	Fax:	E-Mail:
Customer Contact Name:		Quantity:

**SHEAVE INFORMATION**

Sheave Diameter: \_\_\_\_\_  
 Wire Rope Size: \_\_\_\_\_  
 Number of Sheaves: \_\_\_\_\_

**BEARING TYPE**

Bronze Bushing       Roller Bearing  
 Tapered Roller Bearing    Other

**BLOCK INFORMATION**

Dimensions: A. \_\_\_\_\_ B. \_\_\_\_\_ C. \_\_\_\_\_ D. \_\_\_\_\_  
 Working Load Limit: \_\_\_\_\_  
 CMAA Rating: \_\_\_\_\_

**LOWER FITTING TYPE**

Single Point Hook  
 Duplex Hook  
 Swivel Hook Latch  
 Other

**BLOCK HOTLINE**

(1-800-727-1555)

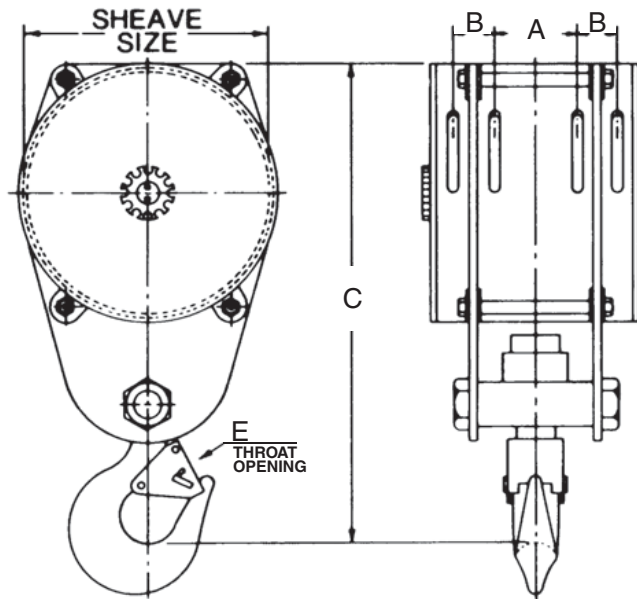

**APPLICATION INFORMATION**

Overhaul Weight Requirements: \_\_\_\_\_  
 Lead Line Speed: \_\_\_\_\_  
 Environment: \_\_\_\_\_

**SPECIAL REQUIREMENTS**

Special Testing: \_\_\_\_\_  
 Finish: \_\_\_\_\_  
 Third Party Inspection / Approval: \_\_\_\_\_

(If 3rd Party Inspection or Approval is required, please refer to page 451-452.)

Four Position Locking Mechanism  
 Other (Specify)



Company Name:	Country:	Date:
Address:	City:	State, Zip:
Phone:	Fax:	E-Mail:
Customer Contact Name:		Quantity:

**SHEAVE INFORMATION**

Sheave Diameter: \_\_\_\_\_ Wire Rope Size: \_\_\_\_\_ Number of Sheaves: \_\_\_\_\_

**BEARING TYPE**

- Bronze Bushing       Roller Bearing
- Tapered Roller Bearing       Other

**BLOCK INFORMATION**

Working Load Limit: \_\_\_\_\_

**Fitting Type**

- Single Point Hook
- Shackle
- Bolt
- M491
- Other

Maximum Weight \_\_\_\_\_

Maximum Length \_\_\_\_\_



**APPLICATION INFORMATION**

Describe Application: \_\_\_\_\_

Lead Line Speed: \_\_\_\_\_

Environment: \_\_\_\_\_

**SPECIAL REQUIREMENTS**

Special Testing: \_\_\_\_\_

Finish: \_\_\_\_\_

Third Party Inspection / Approval: \_\_\_\_\_  
 (If 3rd party Inspection or Approval is required, please refer to page 475-476.)

Other (Specify) \_\_\_\_\_

**BLOCK REQUIREMENTS – confirm the following:**

- Material traceability, impact chemistry reports, tensile test reports, magnetic particle inspection per ASTM E-709 on the following components: HOOK, HOOK NUT, HOOK TRUNNION, CENTER PIN, SIDE PLATE, SHEAVE (no MPI or impact on sheave) and DEAD END.
- Sheave diameter based on D/d ratio based on pitch equal to 18/1. Weight plates produced from plate steel. Hook to rotate on thrust bearing with grease fitting. Sheave bearing to be roller bearings with grease fitting.

Rating #1: Cv =			W.L.L. =	(T or mt) with design factor =
Rating #2: Cv =			W.L.L. =	(T or mt) with design factor =
Personnel rating =				
Wire rope size		Minimum desired weight		
Number of sheaves		Parts of line = 2 times number of sheaves =		

- Design Service Temperature = \_\_\_\_\_ (standard is 0°C. +32°F)
- 3rd Party ABS, DNV, etc.
- Proof test to 2 times the WLL.

**OVERHAUL BALL REQUIREMENTS – confirm the following:**

- Material traceability, chemistry, tensile test, magnetic particle inspection per ASTM E-709 on the following components: SWIVEL EYE, FIXED EYE, SWIVEL BASE, PLUG, CASE PIN, HOOK PIN AND HOOK.
- Charpy impact tests with reports on HOOK, testing to be performed per API-2C latest revision. Impact test with reports on SWIVEL EYE, FIXED EYE, SWIVEL BASE, PLUG, CASE PIN AND HOOK PIN, testing to be performed per API-2C latest revision.

Eye to rotate on thrust with grease fitting.			
Rating #1: Cv =		W.L.L. =	(T or mt) with design factor =
Rating #2: Cv =		W.L.L. =	(T or mt) with design factor =
Personnel rating =			
Wire rope size		Minimum desired weight	

- Design Service Temperature = \_\_\_\_\_ (standard is 0°C. +32°F)
- 3rd Party ABS, DNV, etc.
- Proof test to 2 times the WLL.

**SELECT DESIRED TAG**

<b>McKISSICK®</b> API-2C BLOCK / BALL	
*ONBD Cv	WLL _____ TONS
*OFFBD Cv	WLL _____ TONS
PERSONNEL WLL	_____ TONS
W/L _____ IN	DSN TEMP _____ °F
WT _____ LBS	S/N _____
MODEL _____	*BLOCK / BALL MEET THE REQUIREMENTS OF API-2C.
ASSY NO _____	
<b>⚠ DANGER</b>	
TO LIFT MEN, USE POSITIVE LOCKING HOOK LATCH PER OSHA 1926.1431 (g)(1)(i)(A) & 1926.1501 (g)(4)(iv)(B)	

**OR**

<b>McKISSICK®</b> API-2C BLOCK / BALL	
*Cv	WLL _____ METRIC TONS
*Cv	WLL _____ METRIC TONS
PERSONNEL WLL	_____ METRIC TONS
W/L _____ MM	DSN TEMP _____ °C
WT _____ KG	S/N _____
MODEL _____	*BLOCK / BALL MEET THE REQUIREMENTS OF API-2C.
ASSY NO _____	
<b>⚠ DANGER</b>	
TO LIFT MEN, USE POSITIVE LOCKING HOOK LATCH PER OSHA 1926.1431 (g)(1)(i)(A) & 1926.1501 (g)(4)(iv)(B)	

**WEDGE SOCKET REQUIREMENTS – confirm the following:**

- Material traceability, chemistry, tensile test, magnetic particle inspection per ASTM E-709 on the following components: SOCKET BODY AND PIN.
- Charpy impact test with reports on SOCKET BODY AND PIN, testing to be performed at per API-2C latest revision.
- Wire rope size \_\_\_\_\_
- 3rd Party ABS, DNV, etc.





Company Name:		Date:
Address:		
City:	State, Zip:	Country:
Phone:	Fax:	E-Mail:
Customer Contact Name:		Quantity:

**SWIVEL**

- Angular Contact Bearing
- Tapered Roller Bearing

**SWIVEL STYLE**

- Jaw & Hook
- Jaw & Jaw
- Jaw & Eye
- Eye & Jaw
- Eye & Eye
- Eye & Hook
- Bullet Jaw & Jaw (ACBS only)

**APPLICATION INFORMATION**

WLL required: \_\_\_\_\_ Hook Size: \_\_\_\_\_

**FREQUENCY OF USE**

Continuous: \_\_\_\_\_ Intermittent: \_\_\_\_\_ One Time: \_\_\_\_\_

**SPECIAL REQUIREMENTS**

Special Testing: \_\_\_\_\_

Finish: \_\_\_\_\_

Third Party Inspection / Approval: \_\_\_\_\_

(If 3rd Party Inspection or Approval is required, please refer to page 475-476.)

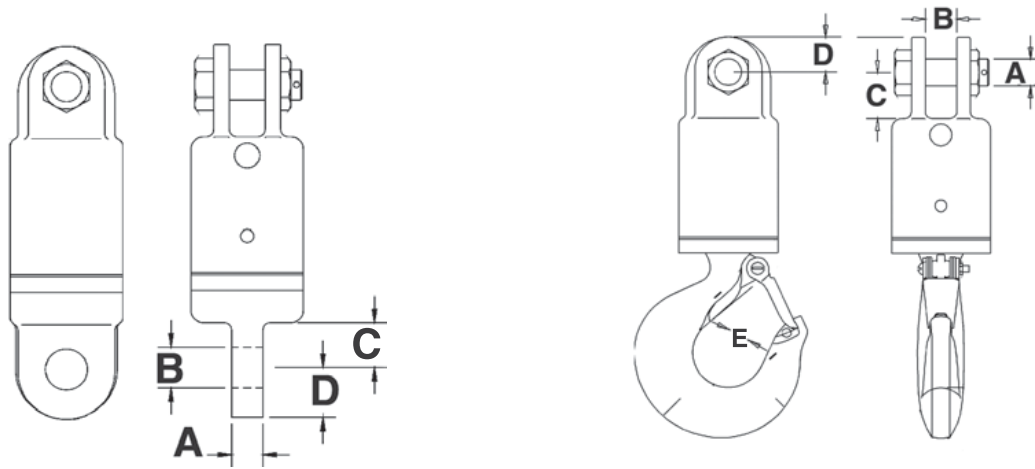

Dimensions for Eye

- A \_\_\_\_\_
- B \_\_\_\_\_
- C \_\_\_\_\_
- D \_\_\_\_\_

Dimensions for Jaw

- A \_\_\_\_\_
- B \_\_\_\_\_
- C \_\_\_\_\_
- D \_\_\_\_\_
- E \_\_\_\_\_ throat opening

**CUSTOM DECK MOUNTED ANCHOR FAIRLEADERS**

Company Name:		Date:
Address:	City:	State, Zip:
Phone:	Fax:	E-Mail:
Name:	Country:	Quantity:

**SHEAVE INFORMATION**

Sheave Diameter: \_\_\_\_\_ Wire Rope Size: \_\_\_\_\_ Number of Sheaves: 1 \_\_\_ or 2 \_\_\_

**BEARING TYPE- Sheave**       Bronze Bushing     Roller Bearing     Tapered Roller Bearing     Other

**BEARING TYPE- Barrel**       Bronze Bushing     Roller Bearing     Tapered Roller Bearing     Other

**BLOCK INFORMATION**

Style:  Pedestal Mount     Base Mount

Dimensions: A. \_\_\_\_\_ B. \_\_\_\_\_ C. \_\_\_\_\_ D. \_\_\_\_\_

**APPLICATION INFORMATION**

Lead Line Speed: \_\_\_\_\_ Single Line Pull: \_\_\_\_\_ Degree of Wrap: \_\_\_\_\_

Environment: \_\_\_\_\_

**FREQUENCY OF USE**

Continuous: \_\_\_\_\_ Intermittent: \_\_\_\_\_ One Time: \_\_\_\_\_

**SPECIAL REQUIREMENTS**

Special Testing: \_\_\_\_\_

Finish: \_\_\_\_\_

Third Party Inspection / Approval: \_\_\_\_\_

(If 3rd Party Inspection or Approval is required, please refer to page 451-452.)

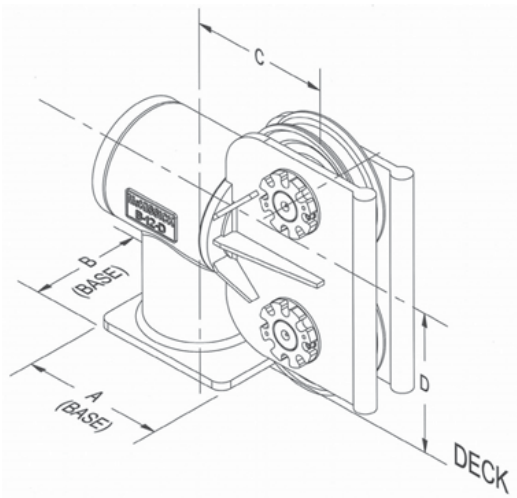

Base Mount (2 sheave version shown)

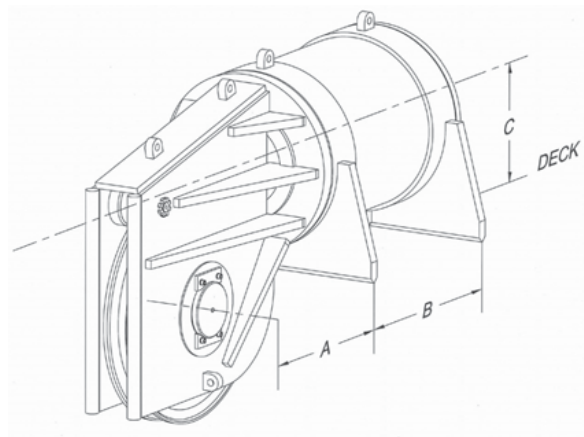

Pedestal Mount (1 sheave version shown)



**CUSTOM PIPE HOOK FORM**

Company Name:	Country:	Date:
Address:	City:	State, Zip:
Phone:	Fax:	E-Mail:
Customer Contact Name:		Quantity:

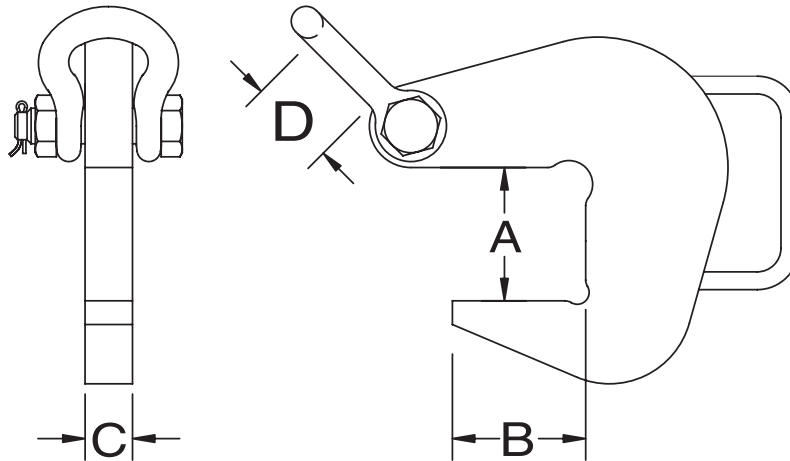

**GENERAL REQUIREMENTS**

Working Load Limit per pair (weight of load): \_\_\_\_\_  Handle Required

**DIMENSIONAL REQUIREMENTS**

Grip Opening (A): \_\_\_\_\_ Grip Depth (B): \_\_\_\_\_

Plate Thickness (C): \_\_\_\_\_ Shackle Opening (D): \_\_\_\_\_

**SPECIAL REQUIREMENTS**

Finish: \_\_\_\_\_  Proof Test Load: \_\_\_\_\_

MPI       UT       Third Party Inspection/Approval: \_\_\_\_\_





# Approval/Inspection Requirement

## THIRD PARTY REQUIREMENTS FORM

Company Name:		
Address:		
City:	State, Zip:	Date:
Phone:	Fax:	E-Mail:
Customer Contact Name:		Country:
Crosby Proposal Number:	Quantity:	
Equipment Description:	Customer P.O.:	
Type of Application:		
End Users / Operator:	Rig/Vessel Name or I.D.:	
Geographical Location:		

### REGULATIONS/ CODES/ STANDARDS

American Bureau of Shipping	Det Norske Veritas	Lloyds Register	Other
<input type="checkbox"/> Guide for the Classification of Drilling Systems	<input type="checkbox"/> Standard for Certification No. 2.7-1 Offshore Containers	<input type="checkbox"/> Lifting Appliances in a Marine Environment	<input type="checkbox"/> API 8C
<input type="checkbox"/> Guide for Certification of Lifting Appliances Guide for Certification of Cranes	<input type="checkbox"/> Standard for Certification No. 2.22 Lifting Appliances	<input type="checkbox"/> Other LR	<input type="checkbox"/> API 2C
<input type="checkbox"/> Steel Vessels Rules	<input type="checkbox"/> Offshore Standard DNVGL-OS-E101 Drilling Plant		<input type="checkbox"/> Other
<input type="checkbox"/> Other ABS	<input type="checkbox"/> Rules for Classification: Offshore Units DNVGL-RU-OU-0101		<input type="checkbox"/>

Other:

### OPERATING CONDITIONS

Minimum Design Temperature:	Working Load:
Load Conditions:	

### EXTENT OF THIRD PARTY INVOLVEMENT:

--



# RIGGING INFORMATION





# The Crosby® appeal...

ap·peal \ə-'pēl\ n [ME *appel*, fr. AF *apel*, fr. *apeler*]

1: to be especially attractive, pleasing, interesting, or enjoyable: The Crosby Group appeals to me...

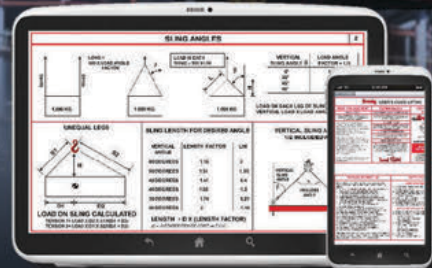
One of many value added features that helps make Crosby® so appealing is our ongoing commitment to utilize the latest technology in order to provide the information required to ensure the proper application of our products. Some of our most popular value added reference guides are now mobile.



  
**Android™**

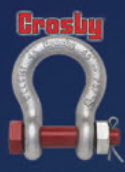

**Pocket Lift Guide - Plus**  
Units: Imperial



**Crosby® Catalog**  
Units: Imperial and Metric



**Sling Calculator**  
Units: Imperial and Metric

**Apple®** 



**Sling Calculator**  
Units: Imperial and Metric



**User's Guide for Lifting - Plus**  
Units: Imperial



**Block Selection and Application Guide - Plus**  
Units: Imperial

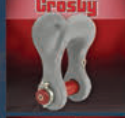

**User's Guide for Heavy Lifts - Plus**  
Units: Imperial

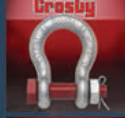

**Pocket Lift Guide - Plus**  
Units: Imperial



**Crosby® Catalog**  
Units: Imperial and Metric

Each app tool offers special enhancements and features that are easy to use and user friendly. Check out all the new Crosby® apps ready for download at the App Store today.



Scan our QR code with your smart device to visit the Crosby® application page.

App Store<sup>SM</sup> is a registered trademark of Apple Inc. Application availability and pricing are subject to change.  
Google Play<sup>TM</sup> store is a trademark of Google Inc. Application availability and pricing are subject to change.

[www.thecrosbygroup.com](http://www.thecrosbygroup.com)







## Crosby USER'S GUIDE

1

Version (08/2009)

RISKMANAGEMENT	TERMINOLOGY	INSPECTION OF FITTINGS
<p><b>DEFINITION</b></p> <p>COMPREHENSIVE SET OF ACTIONS THAT REDUCES THE RISK OF A PROBLEM, A FAILURE, AN ACCIDENT</p> <p><b>YOU NEED</b></p> <ul style="list-style-type: none"> <li>- PRODUCT KNOWLEDGE</li> <li>- APPLICATION KNOWLEDGE</li> <li>- MANUFACTURER OF KNOWN CAPABILITY</li> <li>- PRODUCTS THAT ARE CLEARLY IDENTIFIED WITH THE FOLLOWING:               <ol style="list-style-type: none"> <li>1. MANUFACTURER'S NAME AND LOGO</li> <li>2. LOAD RATING OR SIZE THAT REFERS TO RATINGS</li> <li>3. MATERIAL CLASS (IF APPLICABLE)</li> <li>4. TRACEABILITY CODE (P.I.C.)</li> <li>5. CE(+LOCAL LEGAL REQUIREMENTS)</li> </ol> </li> </ul> <p><b>A GOOD RISK MANAGEMENT PROGRAM RECOGNIZES</b></p> <p>PERFORMANCE REQUIREMENTS INCLUDE THE FOLLOWING:</p> <ol style="list-style-type: none"> <li>1. LOAD RATED PRODUCTS</li> <li>2. QUENCHED AND TEMPERED</li> <li>3. ABILITY TO DEFORM WHEN OVERLOADED.</li> <li>4. ABILITY TO WITHSTAND REAL WORLD LOADING IN DAY TO DAY USE, TOUGHNESS.</li> </ol>	<p><b>WORKING LOAD LIMIT (WLL)</b></p> <p>THE MAXIMUM MASS OR FORCE WHICH THE PRODUCT IS AUTHORIZED TO SUPPORT IN A PARTICULAR SERVICE.</p> <p><b>PROOF TEST</b></p> <p>A TEST APPLIED TO A PRODUCT SOLELY TO DETERMINE INJURIOUS MATERIAL OR MANUFACTURING DEFECTS.</p> <p><b>ULTIMATE STRENGTH</b></p> <p>THE AVERAGE LOAD OR FORCE AT WHICH THE PRODUCT FAILS OR NO LONGER SUPPORTS THE LOAD.</p> <p><b>DESIGN FACTOR (D.F.)</b></p> <p>AN INDUSTRIAL TERM DENOTING A PRODUCTS THEORETICAL RESERVE CAPABILITY: USUALLY COMPUTED BY DIVIDING THE CATALOG ULTIMATE LOAD BY THE WORKING LOAD LIMIT. GENERALLY EXPRESSED AS A RATIO, e.g. 5 to 1.</p> <p></p>	<p><b>DEFORMATION</b></p> <p>CROSBY RECOMMENDS THAT NO SIGNIFICANT DEFORMATION BE ALLOWED.</p> <p><b>WEAR</b></p> <p>ACCEPTABLE LIMITS: 5% WEAR IN THE THROAT &amp; EYE OF HOOKS AND OTHER CRITICAL SECTIONS OF ALL FITTINGS. 10% WEAR IN OTHER AREAS.</p> <p><b>CRACKS</b></p> <p>REMOVE FITTINGS WITH CRACKS FROM SERVICE.</p> <p><b>WELDING AND MODIFICATIONS</b></p> <p>DO NOT WELD ON OR MODIFY FITTINGS OR BLOCKS.</p> <p><b>FOR ADDITIONAL SUPPORT</b></p> <p>YOUR NATIONAL LEGISLATION OVERRULES THESE RECOMMENDATIONS AND INSTRUCTIONS WHERE APPLICABLE.</p>

## Crosby RIGGING HARDWARE

2

Crosby SHACKLES <i>Fatigue Rated</i> <b>QT</b>						Crosby HOOKS <i>Fatigue Rated</i> <b>QT</b>					
G209 G2130	G209A * G2140	CARBON & ALLOY SHACKLES QUENCHED AND TEMPERED				CARBON STEEL WLL		ALLOY STEEL WLL		O THROAT OPENING MM	A - A INDICATOR MM
		D	B	A	C	t	CODE	t	CODE		
1	2	9.65	11.20	16.80	36.60	0.75	DC	1.25	DA	22.6	38
1.5	2.6	11.20	12.70	19.00	42.90	1	FC	1.6	FA	23.1	51
2	3.3	12.70	16.00	20.60	47.80	1.6	GC	2.5	GA	25.4	51
3.25	5	16.00	19.10	26.90	60.50	2	HC	3.2	HA	27.7	51
4.75	7	19.10	22.40	31.80	71.50	3.2	IC	5.4	IA	34.5	63.5
6.5	9.5	22.40	25.40	36.60	84.00	5	JC	8	JA	40.9	76
8.5	12.5	25.40	28.70	42.90	95.50	7.5	KC	11.5	KA	52.8	102
9.5	15	29.50	31.80	46.00	108.00	10	LC	16	LA	57.7	102
12	18	32.80	35.10	51.50	119.00	15	NC	22	NA	76.7	127
13.5	21	36.10	38.10	57.00	133.00	20	OC	30	OA	82.6	165
17	* 30	39.10	41.40	60.50	146.00	25	PC	37	PA	76.2	178
25	* 40	46.70	51.00	73.00	178.00	30	SC	45	SA	85.9	203
35	* 55	53.00	57.00	82.50	197.00	TABLE MADE FOR 319 SHANK HOOKS, 320 EYE HOOKS AND 322 SWIVEL HOOKS					
55	* 85	67.00	70.00	105.00	267.00						

\*WLL IS BASED ON IN-LINE LOADING; SIDE LOADING WILL REDUCE THE RATED WORKING LOAD LIMIT.

\*USE BOLT TYPE SHACKLE FOR PERMANENT INSTALLATION.

\*WHERE THE LOAD MAY SLIDE ON THE SHACKLE PIN CAUSING THE PIN TO ROTATE, ONLY USE BOLT TYPE SHACKLES.

90° MAXIMUM INCLUDED ANGLE

DO NOT TIP LOAD BACK LOAD SIDE LOAD

FOR ADDITIONAL INFORMATION REFER TO THE CATALOG



## Crosby RIGGING HARDWARE

3

### Crosby SHOULDER EYEBOLTS



### Crosby SWIVEL HOIST RING



SHANK DIMENSIONS MM	WLL IN - LINE PULL	WLL 0° < β ≤ 45°	WLL 45° < β ≤ 90°
	t	t	t
M6 X 13	0.20	0.06	0.05
M8 X 13	0.40	0.12	0.10
M10 X 17	0.64	0.19	0.16
M12 X 20.5	1.00	0.30	0.25
M16 X 27	1.80	0.54	0.45
M20 X 30	2.50	0.75	0.62
M24 X 36	4.00	1.20	1.00
M30 X 45	6.00	1.80	1.50
M36 X 54	8.50	2.55	2.12

THREAD SHANK SIZE & EFF. THREAD PROJ.		WLL		TORQUE Nm
MM	MM	D.F. 5/1 t	D.F. 4/1 t	
M8 X 40	16.9	0.40	0.50	10
M10 X 40	16.9	0.45	0.55	16
M12 X 50	17.2	1.05	1.30	38
M16 X 60	27.2	1.90	2.40	81
M20 X 65	31.2	2.15	2.70	136
M20 X 75	28.1	3.00	3.75	136
M24 X 80	33.1	4.20	5.25	312
M30 X 120	65.1	7.00	8.75	637
M36 X 150	60.6	11.00	13.75	1005
M42 X 160	70.6	12.50	15.60	1005
M48 X 160	70.6	13.50	16.90	1350

EYE BOLTS WITH UNC THREADING ARE AVAILABLE

- NEVER EXCEED WORKING LOAD LIMITS
- ONLY USE EYE BOLTS IN NON AGEABLE STEEL IN ACCORDANCE WITH THE MACHINERY DIRECTIVE FOR LIFTING APPLICATIONS.
- ALWAYS USE SHOULDER NUT EYEBOLTS FOR ANGULAR LIFTS
- FOR ANGULAR LIFTS ADJUST WORKING LOAD AS SHOWN ABOVE
- ALWAYS TIGHTEN NUTS SECURELY AGAINST THE LOAD
- ALWAYS APPLY LOAD TO EYE BOLT IN THE PLANE OF THE EYE

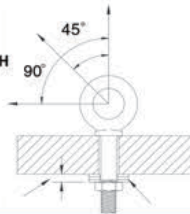

- THE SWIVEL HOIST RING MAINTAINS 100% OF ITS WLL AT ANGULAR LOADING. IT IS SUBJECTED TO THE SAME LOAD AS THE SLING.
- APPLY PROPER TORQUE DURING INSTALLATION.
- NEVER USE SPACERS BETWEEN BUSHING FLANGE AND MOUNTING SURFACE.
- ALWAYS ENSURE FREE MOVEMENT OF BAIL. THERE SHOULD BE NO INTERFERENCE BETWEEN LOAD AND HOIST RING BAIL.



REFER TO THE Crosby GROUP WARNINGS FOR ADDITIONAL INFORMATION

## Crosby RIGGING HARDWARE

4

### Crosby WIRE ROPE CLIPS



SIZE		EFFICIENCY	NUMBER OF CLIPS	TURNBACK LENGTH MM	TORQUE Nm
INCH	MM				
1/8	3 - 4	80%	2	85	6.1
3/16	5	80%	2	95	10.2
1/4	6 - 7	80%	2	120	20.3
5/16	8	80%	2	133	40.7
3/8	9 - 10	80%	2	165	61
7/16	11	80%	2	178	88
1/2	12 - 13	80%	3	292	88
9/16	14 - 15	80%	3	305	129
5/8	16	80%	3	305	129
3/4	18 - 20	80%	4	460	176
7/8	22	80%	4	480	305
1	24 - 26	90%	5	660	305

- APPLY U-BOLT OVER DEAD END OF THE WIRE ROPE, LIVE END OF THE ROPE RESTS IN THE SADDLE; NEVER SADDLE A DEAD HORSE!
- USE THE RECOMMENDED NUMBER OF CLIPS AND APPLY THE RECOMMENDED TORQUE AS SPECIFIED IN THE TABLE.
- A TERMINATION IS ONLY FINISHED WHEN IT HAS BEEN LOADED AT THE REQUIRED WLL AND THE NUTS HAVE BEEN RETORQUED A SECOND TIME.



### Crosby TURNBUCKLES



SIZE		WLL (t) JAW AND EYE D.F. 5/1	WLL (t) HOOK END FITTING D.F. 5/1
INCH	MM		
1/4	6.3	230	180
5/16	8	360	320
3/8	9.5	540	450
1/2	13	1,000	680
5/8	16	1,590	1,020
3/4	19	2,360	1,360
7/8	22	3,270	1,810
1	25	4,540	2,270
1-1/4	32	6,890	-
1-1/2	38	9,710	-
1-3/4	45	12,700	-
2	51	16,780	-

THE USE OF LOCKNUTS OR MOUSING IS AN EFFECTIVE METHOD OF PREVENTING TURNBUCKLES FROM ROTATING.

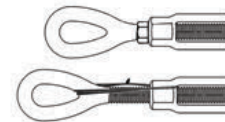

REFER TO THE Crosby CATALOG FOR ADDITIONAL INFORMATION





5

## Crosby BLOCKS AND APPLICATIONS

### WIRE LINE DIRECTION

A SINGLE LINE SHEAVE BLOCK USED TO CHANGE LOAD LINE DIRECTION CAN BE SUBJECTED TO TOTAL LOADS GREATLY DIFFERENT FROM THE LINE PULL.

**TOTAL LOAD = LINE PULL X FACTOR f**

**ANGLE FACTOR MULTIPLIERS f**

ANGLE	FACTOR	ANGLE	FACTOR
0°	2.00	100°	1.29
10°	1.99	110°	1.15
20°	1.97	120°	1.00
30°	1.93	130°	0.84
40°	1.87	135°	0.76
45°	1.84	140°	0.68
50°	1.81	150°	0.52
60°	1.73	160°	0.35
70°	1.64	170°	0.17
80°	1.53	180°	0.00
90°	1.41		

### MECHANICAL ADVANTAGE

- MECHANICAL ADVANTAGE IS THE LEVERAGE GAINED BY A MULTIPLE PART BLOCK.
- MUST HAVE A TRAVELING BLOCK TO HAVE MECHANICAL ADVANTAGE.
- THE THEORETICAL ADVANTAGE IS EQUAL TO THE NUMBER OF PARTS OF LINE SUPPORTING THE TRAVELING BLOCK.
- TO RAISE LOAD 1 M, THE WINCH HAS TO PULL 1 M X THE NUMBER OF PARTS OF LINE.

**EXAMPLE**

NUMBER OF PARTS OF LINE: 4  
 MECHANICAL ADVANTAGE: 4  
 LINE PULL REQUIRED =  $6000/4 = 1500$  KG  
 LOWER BLOCK SIZE: MIN. 6.000 KG  
 UPPER BLOCK SIZE: MIN 6.000 + LINE PULL + WEIGHT OF GEAR  
 TOTAL : > 7.500 KG

### HOW TO FIGURE LINE PARTS

TRUE MECHANICAL BRONZE BUSHED SHEAVES	ADVANTAGE ANTI-FRICTION BEARING SHEAVES	NUMBER OF LINE PARTS
0.96	0.98	1
1.87	1.94	2
2.75	2.88	3
3.59	3.81	4
4.39	4.71	5
5.16	5.60	6
5.90	6.47	7
6.60	7.32	8

### LEAD LINE EFFECT

THE TRUE MECHANICAL ADVANTAGE IS REDUCED AS A RESULT OF FRICTION. THE LEAD LINE WILL HAVE A TENSION GREATER THAN ALL OTHER PARTS OF LINE.

IN THIS EXAMPLE THE LEAD LINE TENSION IS EQUAL TO 1500 KG PLUS FRICTION OF FOUR SHEAVES PLUS EFFORT TO BEND WIRE ROPE.

REFER TO THE Crosby CATALOG FOR ADDITIONAL INFORMATION

6

## Crosby WEDGE SOCKETS

### D/d RATIO - BLOCKS & SHEAVES

**D = SHEAVE PITCH DIAMETER**

**d = WIRE ROPE DIAMETER**

D/d	EFFICIENCY BENDING ROPE REDUCES ITS STRENGTH	FATIGUE LIFE REPEATED BENDING AND STRAIGHTENING OF WIRE ROPE CAUSES "FATIGUING"
	STRENGTH EFFICIENCY COMPARED TO CATALOG STRENGTH IN %	RELATIVE FATIGUED BENDING LIFE
40	95%	
30	93%	10
25	92%	6.6
20	91%	3.8
18	90%	2.9
16	89%	2.1
14	88%	1.5
12	87%	1.1
10	86%	
8	83%	
6	79%	
4	75%	
2	65%	
1	50%	

### ASSEMBLY SAFETY

USE ONLY WITH STANDARD 6 TO 8 STRAND WIRE ROPE OF DESIGNATED SIZE. FOR INTERMEDIATE SIZE ROPE, USE NEXT LARGER SIZE SOCKET. TAIL LENGTH OF DEAD END AS PER FIGURE 1.

- ALIGN LIVE END OF ROPE, WITH CENTER OF PIN. (SEE FIGURE 1)
- SECURE DEAD END SECTION OF ROPE. (SEE FIGURE 1)
- DO NOT ATTACH DEAD END TO LIVE END. (SEE FIGURE 2)
- USE A HAMMER TO SEAT WEDGE AND ROPE AS DEEP INTO SOCKET AS POSSIBLE BEFORE APPLYING FIRST LOAD.
- REFER TO FIGURE 1 FOR ASSEMBLY OF Crosby TERMINATOR WEDGE SOCKET.
- DEAD END SHOULD ALSO BE WELDED, BRAZED OR SEIZED BEFORE INSERTING.

### OPERATING SAFETY

- APPLY FIRST LOAD TO FULLY SEAT THE WEDGE AND WIRE ROPE IN THE SOCKET. THIS LOAD SHOULD BE OF EQUAL OR GREATER WEIGHT THAN LOADS EXPECTED IN USE.
- EFFICIENCY RATING OF THE WEDGE SOCKET TERMINATION IS BASED UPON THE CATALOG BREAKING STRENGTH OF WIRE ROPE. THE EFFICIENCY OF A PROPERLY ASSEMBLED WEDGE SOCKET IS 80%.

REFER TO THE Crosby CATALOG FOR ADDITIONAL INFORMATION

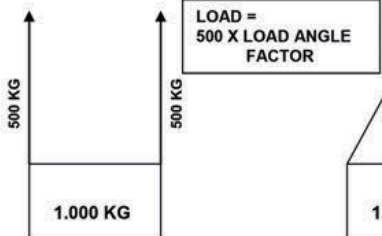
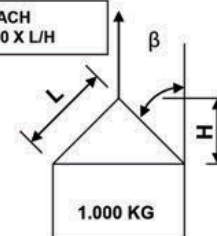
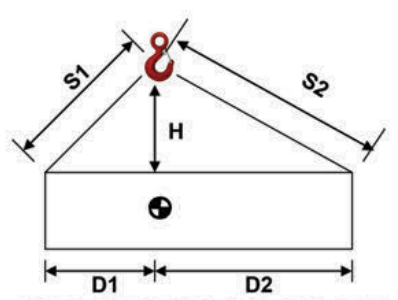
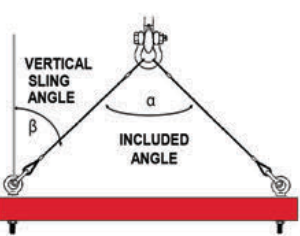

THE BASIC RIGGING PLAN:	RESPONSIBILITY <span style="float: right;">7</span>
<p><b>1 WHO IS RESPONSIBLE (COMPETENT) FOR THE RIGGING?</b> COMMUNICATIONS ESTABLISHED?</p> <p><b>2. IS THE EQUIPMENT IN ACCEPTABLE CONDITION?</b> APPROPRIATE TYPE, PROPER IDENTIFICATION?</p> <p><b>3. ARE THE WORKING LOAD LIMITS ADEQUATE?</b> CAPACITY OF GEAR KNOWN? WHAT IS WEIGHT OF LOAD? WHERE IS THE CENTER OF GRAVITY? WHAT IS THE SLING ANGLE? WILL THERE BE ANY ANGULAR OR SIDE LOADING? ARE THE SLINGS PADDED AGAINST CORNERS, EDGES, PROTRUSIONS AND ABRASIVE SURFACES?</p> <p><b>4. WILL THE LOAD BE UNDER CONTROL?</b> IS THE LOAD RIGGED TO THE CENTER OF GRAVITY? IS THE HITCH APPROPRIATE? TAG LINE NEEDED? IS THERE ANY POSSIBILITY OF FOULING? CLEAR OF PERSONNEL?</p> <p><b>5. ARE THERE ANY UNUSUAL LOADING OR ENVIRONMENTAL CONDITIONS?</b> WIND, TEMPERATURE, OTHER?</p> <p><b>6. YOUR SPECIAL REQUIREMENTS?</b></p> <div style="display: flex; justify-content: space-around;">   </div>	<p style="text-align: center;"><b>USER RESPONSIBILITY</b></p> <p>UTILIZE APPROPRIATE RIGGING GEAR SUITABLE FOR OVERHEAD LIFTING.</p> <p>UTILIZE THE RIGGING GEAR WITHIN INDUSTRY STANDARDS AND THE MANUFACTURER'S RECOMMENDATIONS.</p> <p>CONDUCT REGULAR INSPECTION AND MAINTENANCE OF THE RIGGING GEAR.</p> <p style="text-align: center;"><b>MANUFACTURER RESPONSIBILITY</b></p> <p>PRODUCT AND APPLICATION INFORMATION PRODUCT THAT IS CLEARLY IDENTIFIED</p> <ul style="list-style-type: none"> <li>NAME OR LOGO</li> <li>LOAD RATING AND SIZE</li> <li>QUALITY CONTROL</li> <li>TRACEABILITY</li> <li>CE (+ LOCAL LEGAL REQUIREMENTS)</li> <li>MATERIAL CLASS (IF APPLICABLE)</li> </ul> <p>PRODUCT PERFORMANCE</p> <ul style="list-style-type: none"> <li>WORKING LOAD LIMIT</li> <li>DUCTILITY</li> <li>FATIGUE PROPERTIES</li> <li>IMPACT PROPERTIES</li> </ul> <div style="text-align: right;">  </div>

SLING ANGLES <span style="float: right;">8</span>																							
 <p>LOAD = 500 X LOAD ANGLE FACTOR</p>	 <p>LOAD IN EACH SLING = 500 X L/H</p>	<table border="1"> <thead> <tr> <th>VERTICAL SLING ANGLE <math>\beta</math></th> <th>LOAD ANGLE FACTOR = L/H</th> </tr> </thead> <tbody> <tr> <td>0°</td> <td>1.00</td> </tr> <tr> <td>30°</td> <td>1.16 (1.2)</td> </tr> <tr> <td>45°</td> <td>1.41 (1.4)</td> </tr> <tr> <td>60°</td> <td>2.00 (2.0)</td> </tr> </tbody> </table> <p>LOAD ON EACH LEG OF SLING = VERTICAL LOAD X LOAD ANGLE FACTOR</p>	VERTICAL SLING ANGLE $\beta$	LOAD ANGLE FACTOR = L/H	0°	1.00	30°	1.16 (1.2)	45°	1.41 (1.4)	60°	2.00 (2.0)											
VERTICAL SLING ANGLE $\beta$	LOAD ANGLE FACTOR = L/H																						
0°	1.00																						
30°	1.16 (1.2)																						
45°	1.41 (1.4)																						
60°	2.00 (2.0)																						
<p style="text-align: center;"><b>UNEQUAL LEGS</b></p>  <p><b>LOAD ON SLING CALCULATED</b></p> <p>TENSION 1= LOAD X D2 X S1/H(D1 + D2)</p> <p>TENSION 2= LOAD X D1 X S2/H(D1 + D2)</p>	<p style="text-align: center;"><b>SLING LENGTH FOR DESIRED ANGLE</b></p> <table border="1"> <thead> <tr> <th>VERTICAL ANGLE</th> <th>LENGTH FACTOR</th> <th>L/H</th> </tr> </thead> <tbody> <tr> <td>60 DEGREES</td> <td>1.15</td> <td>2</td> </tr> <tr> <td>50 DEGREES</td> <td>1.31</td> <td>1.55</td> </tr> <tr> <td>45 DEGREES</td> <td>1.41</td> <td>1.4</td> </tr> <tr> <td>40 DEGREES</td> <td>1.55</td> <td>1.3</td> </tr> <tr> <td>35 DEGREES</td> <td>1.74</td> <td>1.21</td> </tr> <tr> <td>30 DEGREES</td> <td>2</td> <td>1.16</td> </tr> </tbody> </table> <p><b>LENGTH = D X (LENGTH FACTOR)</b></p> <p>(D = DISTANCE PICK-UP POINT @ C.O.G.)</p>	VERTICAL ANGLE	LENGTH FACTOR	L/H	60 DEGREES	1.15	2	50 DEGREES	1.31	1.55	45 DEGREES	1.41	1.4	40 DEGREES	1.55	1.3	35 DEGREES	1.74	1.21	30 DEGREES	2	1.16	<p style="text-align: center;"><b>VERTICAL SLING ANGLE = 1/2 INCLUDED ANGLE</b></p> 
VERTICAL ANGLE	LENGTH FACTOR	L/H																					
60 DEGREES	1.15	2																					
50 DEGREES	1.31	1.55																					
45 DEGREES	1.41	1.4																					
40 DEGREES	1.55	1.3																					
35 DEGREES	1.74	1.21																					
30 DEGREES	2	1.16																					





### CENTER OF GRAVITY AND SLING LOADING

WHEN LIFTING VERTICALLY, THE LOAD WILL BE SHARED EQUALLY IF THE CENTER OF GRAVITY IS PLACED EQUALLY BETWEEN THE PICK POINTS. IF THE WEIGHT OF LOAD IS 10,000 KG, THEN EACH SLING WILL HAVE A LOAD OF 5,000KG AND EACH SHACKLE AND EYEBOLT WILL ALSO HAVE A LOAD OF 5,000 KG.

WHEN THE CENTER OF GRAVITY IS NOT EQUALLY SPACED BETWEEN THE PICK POINTS, THE SLINGS AND FITTINGS WILL NOT CARRY AN EQUAL SHARE OF THE LOAD. THE SLING CONNECTED TO THE PICK POINT CLOSEST TO THE CENTER OF GRAVITY WILL CARRY THE GREATEST SHARE OF THE LOAD.

SLING 2 IS CLOSEST TO COG. IT WILL HAVE THE GREATEST SHARE OF THE LOAD.

SLING 2 :  $10,000 \times 8 / (8 + 2) = 8,000 \text{ KG}$   
 SLING 1 :  $10,000 \times 2 / (8 + 2) = 2,000 \text{ KG}$

### CALCULATE WEIGHT

**EXAMPLE - FLATS**

$WEIGHT = L \times W \times H \times \text{UNIT WEIGHT}$

L = 5 m  
H = 0.1 m  
W = 2 m

**IF STEEL: UNIT WEIGHT = 7.85 t/m<sup>3</sup>**  
 WEIGHT = 5 m X 2 m X 0.1 m X 7.85 t/m<sup>3</sup> = 7.85 t

**IF ALUMINUM: UNIT WEIGHT = 2.64 t/m<sup>3</sup>**  
 WEIGHT = 5 m X 2 m X 0.1 m X 2.64 t/m<sup>3</sup> = 2.64 t

**IF CONCRETE: UNIT WEIGHT = 2.40 t/m<sup>3</sup>**  
 WEIGHT = 5 m X 2 m X 0.1 m X 2.40 t/m<sup>3</sup> = 2.40 t

### CALCULATE WEIGHT

**EXAMPLE - SOLID CYLINDER**

$WEIGHT = \frac{3.14 \times D^2}{4} \times L \times \text{UNIT WEIGHT}$

L = 5 m  
D = 0.5 m

**IF STEEL: UNIT WEIGHT = 7.85 t/m<sup>3</sup>**  
 WEIGHT =  $\frac{3.14 \times 0.5^2}{4} \times 5 \text{ m} \times 7.85 \text{ t/m}^3 = 7.70 \text{ t}$

**IF CONCRETE: UNIT WEIGHT = 2.40 t/m<sup>3</sup>**  
 WEIGHT =  $\frac{3.14 \times 0.5^2}{4} \times 5 \text{ m} \times 2.40 \text{ t/m}^3 = 2.35 \text{ t}$

### LOAD STABILITY AND THE CENTER OF GRAVITY

CONNECTION TO THE LOAD MUST BE MADE ABOVE THE CENTER OF GRAVITY. IF NOT, THE LOAD IS UNSTABLE AND WILL SHIFT. KEEP DISTANCE FROM COG TO SLING AS LARGE AS POSSIBLE.

### WIRE ROPE SLINGS AND CONNECTIONS TO FITTINGS

USE A THIMBLE TO PROTECT SLING AND TO INCREASE D/d RATIO.

NEVER PLACE EYE OVER A FITTING WITH A SMALLER DIAMETER OR WIDTH THAN THE ROPE'S DIAMETER.

### WIRE ROPE SLINGS AND CONNECTIONS TO FITTINGS

NEVER PLACE A SLING EYE GREATER THAN ONE HALF THE NATURAL LENGTH OF THE EYE (L).

1/3(L) FOR SYNTHETICS.

### CHOKER HITCHES

A CHOKER HITCH HAS 80% OF THE CAPACITY OF A SINGLE LEG ONLY IF THE CORNERS ARE SOFTENED AND THE VERTICAL SLING ANGLE  $\beta$  IS SMALLER THAN 60°. USE BLOCKS TO PREVENT ANGLES GREATER THAN 60°.

### BASKET HITCH

A BASKET HITCH HAS TWICE THE CAPACITY OF A SINGLE LEG ONLY IF THE D/d RATIO  $\geq 25/1$  AND LEGS OF SLING ARE VERTICAL.

AT OTHER ANGLES, SEE TABLE.

ANGLE $\beta$	PERCENTAGE OF SINGLE LEG CAPACITY
0	200%
30	170%
45	140%
60	100%

ANGLE OF CHOKE	SLING RATED LOAD PERCENTAGE OF SINGLE LEG SLING CAPACITY
120° - 180°	80%
90° - 119°	65%
60° - 89°	55%
30° - 59°	40%



## INSPECTION OF HARDWARE

### DEFORMATION

REMOVE FROM SERVICE IF ANY SIGNIFICANT DEFORMATION. CHECK THROAT OPENING OF HOOKS.

### WEAR

REMOVE FROM SERVICE IF EXCESSIVE WEAR. WEAR IS EXCESSIVE IF:  
 MORE THAN 5% WEAR IN THROAT OR EYE OF HOOK AND OTHER CRITICAL AREAS OF HARDWARE.  
 MORE THAN 10% WEAR IN OTHER AREAS.

### CRACKS, NICKS, GOUGES

REMOVE FROM SERVICE IF CRACKS, NICKS, OR GOUGES ARE DETECTED.

### MODIFICATION

DO NOT WELD, DO NOT SUBSTITUTE SHACKLES PINS OR OTHER COMPONENTS, DO NOT HEAT, BEND OR MODIFY IN ANY MANNER.

### PROPER FUNCTION

IMPROPERLY INSTALLED HARDWARE OR MALFUNCTION IS CAUSE FOR REMOVAL. CHECK FOR LATCHES, SWIVEL BEARINGS, LOCKING DEVICES, AND INSTALLATION OF WIRE ROPE CLIPS AND WEDGE SOCKETS.

## INSPECTION OF WIRE ROPE SLINGS

11

ALL SLINGS AND ATTACHMENTS SHALL BE VISUALLY INSPECTED BY THE PERSON HANDLING THE SLING EACH DAY THEY ARE USED. IN ADDITION, A PERIODIC INSPECTION SHALL BE PERFORMED BY A COMPETENT PERSON, AT LEAST ONCE EVERY 6 MONTHS (OR PER LEGAL REQUIREMENTS) AND SHALL INCLUDE A RECORD OF THE INSPECTION.

### INSPECTION CRITERIA

KINKING	CORE PROTRUSION
CRUSHING	CORROSION
UNSTRANDING	BROKEN OR CUT STRANDS
BIRDCAGING	BROKEN WIRES
STRAND DISPLACEMENT	

### BROKEN WIRES

REFER TO THE APPLICABLE STANDARDS SUCH AS ISO 4309 WITH SPECIFIC DISCARD CRITERIA AND GUIDANCE REGARDING THE NUMBER OF BROKEN WIRES.

### DISTORTION OF WIRE ROPE

REMOVE FROM SERVICE WIRE ROPE SLINGS THAT HAVE ANY DAMAGE RESULTING IN DISTORTION OF THE WIRE ROPE STRUCTURE SUCH AS KINKING, CRUSHING, UNSTRANDING, BIRD CAGING, STRAND DISPLACEMENT OR CORE PROTRUSION.

Remember - "When buying Crosby, you're buying more than product, you're buying *Quality*."

## WIRE ROPE SLING CAPACITIES (t) (refer to standard EN13414-1)

12

WORKING LOAD LIMITS FOR SLINGS USING STEEL CORED ROPE OF CLASSES 6X19, 6X36 AND 8X36 AND

HAVING FERRULE-SECURED EYE TERMINATIONS TENSILE STRENGTH 1770 kN/mm<sup>2</sup> DESIGN FACTOR 5 / 1

WIRE ROPE SIZE		Crosby Q&T CARB. SHACKLE MIN. SHACKLE SIZE FOR A D/d > 1 AT LOAD CONNECTION			TWO LEG SLINGS		THREE AND FOUR LEG SLINGS	
MM	MBL (kN)				SHACKLE SIZE (INCH)	VERTICAL (SINGLE LEG) t	CHOKER t	0° < β ≤ 45° t
8	40.3	3/8	0.75	0.60	1.05	0.75	1.55	1.10
10	63.0	7/16	1.15	0.92	1.60	1.15	2.40	1.70
12	90.7	1/2	1.70	1.36	2.30	1.70	3.55	2.50
13	106	5/8	2.00	1.60	2.80	2.00	4.15	3.00
14	124	5/8	2.25	1.80	3.15	2.25	4.80	3.40
16	161	3/4	3.00	2.40	4.20	3.00	6.30	4.50
18	204	7/8	3.70	2.96	5.20	3.70	7.80	5.65
20	252	7/8	4.60	3.68	6.50	4.60	9.80	6.90
22	305	1	5.65	4.52	7.80	5.65	11.80	8.40
24	363	1-1/8	6.70	5.36	9.40	6.70	14.00	10.00
26	426	1-1/8	7.80	6.24	11.00	7.80	16.50	11.50
28	494	1-1/4	9.00	7.20	12.50	9.00	19.00	13.50
32	645	1-3/8	11.80	9.44	16.50	11.80	25.00	17.50
36	817	1-1/2	15.00	12.00	21.00	15.00	31.50	22.50

RATED CAPACITIES (t) BASED ON PIN DIAMETER OR HOOK NO LARGER THAN THE NATURAL EYE WIDTH (1/2 X EYE LENGTH) OR LESS THAN THE NOMINAL SLING DIAMETER. TURNBACK EFFICIENCY: k = 0,9 FLEMISH EYE TERMINATION OFFERS A HIGHER EFFICIENCY

REFER TO EN 13414-1 FOR FULL DETAILS  
 VERTICAL SLING ANGLES GREATER THAN 60° ARE NOT RECOMMENDED!





## CHAIN SLING CAPACITIES (t) - GRADE 8/80 IN ACCORDANCE EN 818-4

13

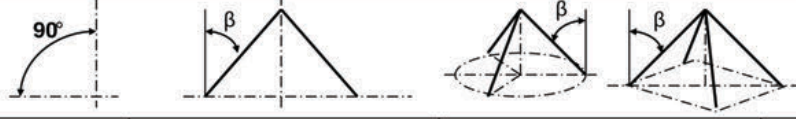

A CHOKER HAS 80% OF THE CAPACITY OF A SINGLE LEG ONLY IF THE CORNERS ARE SOFTENED AND THE VERTICAL ANGLE  $\beta$  IS SMALLER THAN 60°.

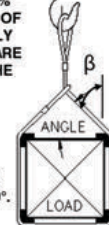

USE BLOCKS TO PREVENT ANGLES GREATER THAN 60°.

CHAIN SIZE MM	VERTICAL (SINGLE LEG) t	TWO LEG SLINGS		THREE & FOUR LEG SLINGS		CHOKER t
		$0^\circ < \beta \leq 45^\circ$ t	$45^\circ < \beta \leq 60^\circ$ t	$0^\circ < \beta \leq 45^\circ$ t	$45^\circ < \beta \leq 60^\circ$ t	
6	1.12	1.60	1.12	2.36	1.70	0.90
7	1.50	2.12	1.50	3.15	2.24	1.20
8	2.00	2.80	2.00	4.25	3.00	1.60
10	3.15	4.25	3.15	6.70	4.75	2.50
13	5.30	7.50	5.30	11.20	8.00	4.25
16	8.00	11.20	8.00	17.00	11.80	6.40
19	11.20	16.00	11.20	23.60	17.00	9.00
22	15.00	21.20	15.00	31.50	22.40	12.00
26	21.20	30.00	21.20	45.00	31.50	17.00
32	31.50	45.00	31.50	67.00	47.50	25.20

**INSPECTION OF CHAIN SLINGS**

ALL SLINGS AND ATTACHMENTS SHALL BE VISUALLY INSPECTED BY THE PERSON HANDLING THE SLING EACH DAY THEY ARE USED. IN ADDITION, A PERIODIC INSPECTION SHALL BE PERFORMED BY A DESIGNATED PERSON, AT LEAST ANNUALLY, AND SHALL INCLUDE A RECORD OF THE INSPECTION.

**INSPECTION CRITERIA**

WEAR NICKS, CRACKS, BREAKS GOUGES, STRETCH, BENDS	WELD SPLATTER EXCESSIVE TEMPERATURE THROAT OPENING OF HOOK
---	--

**CHAIN LINKS**

REMOVE SLING FROM SERVICE IF LINKS ARE WORN EXCESSIVELY (MORE THAN 10% OR REFER TO MANUFACTURER'S INFORMATION), SHARP TRANSVERSE NICKS AND GOUGES SHOULD BE ROUNDED OUT BY GRINDING (DO NOT EXCEED WEAR ALLOWANCE). CHAIN LINKS AND ATTACHMENTS SHOULD HINGE FREELY TO ADJACENT LINKS.

**IDENTIFICATION**

CHAIN SLINGS SHALL HAVE PERMANENTLY AFFIXED IDENTIFICATION STATING: SIZE, GRADE, RATED LOAD, VERTICAL SLING ANGLE, NAME OF MANUFACTURER AND  $\text{CE}$  (EN818-4)

**TRIPLE LEG SLINGS HAVE 50% MORE CAPACITY THAN DOUBLE LEG ONLY IF THE CENTER OF GRAVITY IS IN THE CENTER OF CONNECTION POINT AND THE LEGS ARE ADJUSTED PROPERLY. (EQUAL SHARE OF THE LOAD)**

**QUAD LEG SLINGS OFFER IMPROVED STABILITY BUT DO NOT PROVIDE INCREASED LIFTING CAPACITY.**

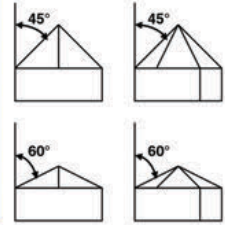

## CHAIN SLING CAPACITIES (t) - GRADE 10/100

14



A CHOKER HAS 80% OF THE CAPACITY OF A SINGLE LEG ONLY IF THE CORNERS ARE SOFTENED AND THE VERTICAL ANGLE  $\beta$  IS SMALLER THAN 60°.

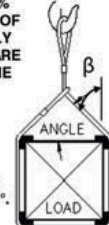

USE BLOCKS TO PREVENT ANGLES GREATER THAN 60°.

CHAIN SIZE MM	VERTICAL (SINGLE LEG) t	TWO LEG SLINGS		THREE & FOUR LEG SLINGS		CHOKER t
		$0^\circ < \beta \leq 45^\circ$ t	$45^\circ < \beta \leq 60^\circ$ t	$0^\circ < \beta \leq 45^\circ$ t	$45^\circ < \beta \leq 60^\circ$ t	
6	1.40	2.00	1.40	3.00	2.12	1.12
7	2.00	2.80	2.00	4.20	3.00	1.60
8	2.50	3.55	2.50	5.30	3.75	2.00
10	4.00	5.60	4.00	8.00	6.00	3.20
13	6.70	9.50	6.70	14.00	10.00	5.35
16	10.00	14.00	10.00	21.20	15.00	8.00
19	14.00	20.00	14.00	30.00	21.00	11.20
22	18.75	26.50	18.75	39.40	28.00	15.00
26	26.50	37.00	26.50	55.50	40.00	21.20
32	40.00	56.00	40.00	85.00	60.00	32.50

**INSPECTION OF CHAIN SLINGS**

ALL SLINGS AND ATTACHMENTS SHALL BE VISUALLY INSPECTED BY THE PERSON HANDLING THE SLING EACH DAY THEY ARE USED. IN ADDITION, A PERIODIC INSPECTION SHALL BE PERFORMED BY A DESIGNATED PERSON, AT LEAST ANNUALLY, AND SHALL INCLUDE A RECORD OF THE INSPECTION.

**INSPECTION CRITERIA**

WEAR NICKS, CRACKS, BREAKS GOUGES, STRETCH, BENDS	WELD SPLATTER EXCESSIVE TEMPERATURE THROAT OPENING OF HOOK
---	--

**CHAIN LINKS**

REMOVE SLING FROM SERVICE IF LINKS ARE WORN EXCESSIVELY (MORE THAN 10% OR REFER TO MANUFACTURER'S INFORMATION), SHARP TRANSVERSE NICKS AND GOUGES SHOULD BE ROUNDED OUT BY GRINDING (DO NOT EXCEED WEAR ALLOWANCE). CHAIN LINKS AND ATTACHMENTS SHOULD HINGE FREELY TO ADJACENT LINKS.

**IDENTIFICATION**

CHAIN SLINGS SHALL HAVE PERMANENTLY AFFIXED IDENTIFICATION STATING: SIZE, GRADE, RATED LOAD, VERTICAL SLING ANGLE, NAME OF MANUFACTURER AND  $\text{CE}$  (EN818-4)

**TRIPLE LEG SLINGS HAVE 50% MORE CAPACITY THAN DOUBLE LEG ONLY IF THE CENTER OF GRAVITY IS IN THE CENTER OF CONNECTION POINT AND THE LEGS ARE ADJUSTED PROPERLY. (EQUAL SHARE OF THE LOAD)**

**QUAD LEG SLINGS OFFER IMPROVED STABILITY BUT DO NOT PROVIDE INCREASED LIFTING CAPACITY.**

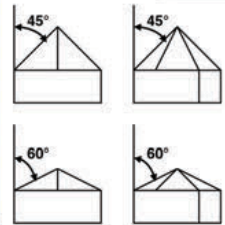



## WEB SLING CAPACITIES IN ACCORDANCE WITH EN 1492-1/2

15

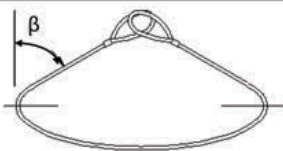
VERTICAL (SINGLE LEG)	CHOKER	BASKET	2 - LEG SLINGS				3- / 4 - LEG SLINGS											
			0° <math>\beta \le 45^\circ</math>		45° <math>\beta \le 60^\circ</math>		0° <math>\beta \le 45^\circ</math>	45° <math>\beta \le 60^\circ</math>										
			t	t	t	t	t	t										
Violet	1.0	0.8	2.0	1.4	1.0	2.1	1.5	<table border="1"> <thead> <tr> <th>ANGLE <math>\beta</math></th> <th>PERCENTAGE OF SINGLE LEG CAPACITY</th> </tr> </thead> <tbody> <tr> <td>0</td> <td>200%</td> </tr> <tr> <td>30</td> <td>170%</td> </tr> <tr> <td>45</td> <td>140%</td> </tr> <tr> <td>60</td> <td>100%</td> </tr> </tbody> </table>	ANGLE $\beta$	PERCENTAGE OF SINGLE LEG CAPACITY	0	200%	30	170%	45	140%	60	100%
ANGLE $\beta$	PERCENTAGE OF SINGLE LEG CAPACITY																	
0	200%																	
30	170%																	
45	140%																	
60	100%																	
Green	2.0	1.6	4.0	2.8	2.0	4.2	3.0											
Yellow	3.0	2.4	6.0	4.2	3.0	6.3	4.5											
Grey	4.0	3.2	8.0	5.6	4.0	8.4	6.0											
Red	5.0	4.0	10.0	7.0	5.0	10.5	7.5											
Brown	6.0	4.8	12.0	8.4	6.0	12.6	9.0											
Blue	8.0	6.4	16.0	11.2	8.0	16.8	12.0											
Orange	10.0	8.0	20.0	14.0	10.0	21.8	15.0											

INSPECTION OF SYNTHETIC SLINGS			
<p>ALL SLINGS AND ATTACHMENTS SHALL BE VISUALLY INSPECTED BY THE PERSON HANDLING THE SLING EACH DAY THEY ARE USED. IN ADDITION, A PERIODIC INSPECTION SHALL BE PERFORMED BY A COMPETENT PERSON, AT LEAST ANNUALLY, AND SHALL INCLUDE A RECORD OF THE INSPECTION. EXAMINATION PERIODS TO BE FURTHER DETERMINED BY A COMPETENT PERSON.</p> <p><b>INSPECTION CRITERIA</b></p> <p>ACID OR CAUSTIC BURNS MELTING OR CHARRING HOLES, CUTS TEARS, SNAGS</p>		<p><b>ROUND SLING NOTES</b></p> <p>REMOVE FROM SERVICE ROUND SLINGS THAT HAVE CORE FIBER EXPOSED BY HOLES, TEARS, CUTS, EMBEDDED PARTICLES, WEAR OR SNAGS.</p> <p>REMOVE FROM SERVICE ROUND SLINGS THAT HAVE MELTING, CHARRING OR WELD SPLATTER ON ANY PART OF SLING.</p>	
<p>BROKEN STITCHES WORN STITCHES EXCESSIVE ABRASION KNOTS</p>		<p><b>IDENTIFICATION</b></p> <p>WEB SLINGS AND ROUND SLINGS SHALL HAVE A COLOR CODING AND PERMANENTLY MARKED INDICATING: MANUFACTURER'S TRADEMARK, SERIAL NUMBER, WLL AND  (EN1492-1/2)</p>	

SYNTHETIC SLINGS RATED LOAD	
	
<p>FOLDING, BUNCHING OR PINCHING OF SYNTHETIC SLINGS, WHICH OCCURS WHEN USED WITH SHACKLES, HOOKS OR OTHER APPLICATIONS WILL REDUCE THE RATED LOAD.</p> <p><b>Crosby</b> DESIGNED FITTINGS FOR USE WITH SYNTHETIC SLINGS</p>	

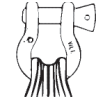

## CROSBY FITTINGS & CHAIN

Alloy Chain .....	227, 242	What It Takes To Be "Crosby or Equal" .....	15, 18, 20, 22, 24, 32, 74, 156, 306
Angular Contact Bearing Swivels.....	138-140	Quality Continuum.....	11, 16
Barrel Hooks .....	133	World Standards.....	18-19
Bolts —		Identification .....	20-21
Machinery Eye Bolts .....	169	Heat Treatment .....	22-23
Regular Eye .....	167	Material Properties .....	24-25
Shoulder Eye .....	168-171	Understanding Product Warnings .....	27-30
Screw Eye .....	168	Forged Wire Rope Clips .....	32-33
Rivet Eye .....	170	Shackles .....	74-75
Ring .....	171	Hoist Hooks 319, 320, 322 .....	112-116
Bullard Hooks.....	124-129, 264	McKissick & Lebus Snatch Blocks .....	306-307
Bundle Clips.....	173	Turnbuckles .....	156-157
Button Spelter Sockets.....	40	Crosby Product Warnings —	
Chain.....	227, 242, 249-252	Warning Elements.....	27-30
Boomer.....	262	Warning Colors.....	30
Grade 30 .....	250	Warning Format .....	30
Grade 40.....	251	<b>Crosby Trawlex.....</b>	<b>438-445</b>
Grade 70 .....	252	Profile Chain .....	440
Grade 80 .....	242	Connectors .....	441-442
Grade 100.....	227	Hooks.....	445
Chain Links .....	160-164	Double Clevis Links .....	255
Chain Shortener Link .....	237	End Links .....	165
Chain Sling Information .....	219-224	Eyes —	
Chain Swivels .....	135	Lifting .....	172
Clamps.....	409-435	Nut .....	172
Clips —		Pad .....	171
Crosby "Red U-Bolt" .....	34	Eye Bolts .....	167-172
Fist Grip .....	35	Fist Grip Clips .....	35
Stainless Steel Clips.....	34	Grade 8 Alloy Chain .....	242
Closed Wire Rope Sockets .....	43, 48	Grade 8 Alloy Fittings .....	240-242
Connecting Links .....	227, 237, 253	High Tensile Transport Chain .....	252
Coupler Link.....	237	High Test Chain .....	251
Crosby Chain .....	227, 242, 249-252	Hoist Rings .....	174-187
<b>Crosby Clamp-Co —</b>		Hooks —	
Barrier Grab .....	434	Grade 80.....	112, 247
Beam Clamps.....	433	Grade 100.....	228-238
Curb Grab.....	434	Barrel .....	133
Pipe Grab.....	430-432	Bullard .....	124-129, 263, 264
Pipe Hooks.....	435	Chain Nest.....	263-264
Crosby Communication System .....	13, 17	Choker .....	132
<b>Crosby IP Clamps —</b>		Clevis Grab .....	233, 256
Beam Clamps .....	419-422	Clevis Sling .....	231
Drum Clamps .....	423	Clevis Slip .....	257
Horizontal Clamps.....	414-418	Eye .....	114-115, 118, 130-131, 235, 238, 247, 256-257
Misc. Clamps —		Eye Grab .....	234, 256
Screw Style .....	428	Eye Sling .....	230
Stinger Assembly.....	428	Eye Slip .....	257
Shipbuilding —		Foundry .....	232
Bulbprofiles .....	425, 427	Latching Clevis .....	235, 247
Shipsections.....	426	Latching Eye .....	118, 235, 247
Vertical Clamps.....	410-413	Replacement .....	134
<b>Crosby Kuplex.....</b>	<b>447-470</b>	Round Reverse Eye .....	133
Application Information .....	464-470	ROV.....	130-131
Clutches .....	458	Shank .....	51, 112-113, 118, 128-129
Connectors .....	457	SHUR-LOC® .....	118-119, 235-236, 263
Hooks and Components .....	457-463	Sling .....	134, 232
Links.....	448-449	Snap .....	133
Terminal Fittings .....	450-454	Sorting .....	134
Crosby Product Bulletins —		Swivel .....	116-117, 119-120, 126, 134, 236, 263-264
How to Assemble Alloy Fittings.....	276	Utility.....	120



Web Sling.....	102	Ring Bolts .....	171
Web Choker.....	103	Rivet Eye Bolts .....	170
Weld-On.....	120	ROV Shackles.....	90-91
Latch Assemblies —		ROV Hooks .....	130-131
4320.....	121, 248	Screw Eye Bolts .....	168
Alloy .....	123, 248	Shackles .....	73-94
PL .....	122	Application Information .....	92-94
SS-4055.....	123	Bolt Type Shackles.....	79-82
Latching Eye Hook .....	118, 235, 247	General Shackle Information.....	74-75
Latching Clevis Hook .....	235, 247	Grommet Shakles .....	87
Lifting Clamps.....	409-435	Screw Pin Shackles.....	77-78
Lifting Eyes .....	172	Subsea Shackles .....	90-91
Lifting Point (SL-150).....	187	Theatrical Shackle .....	89
Links .....	160-166, 228, 243-246	Wide Body Shackle .....	84-85
Lok-A-Loy 6 Connecting Links .....	253	Shoulder Nut Eye Bolts .....	168-169
Lok-A-Loy 10 Connecting Links .....	227	SHUR-LOC® Eye Hook .....	118, 235
Machinery Eye Bolts .....	169	Slide-Loc (SL-150) .....	187
Master Links .....	160-164, 228-229, 243-246	Sling I.D. Tags.....	238
Missing Links .....	254	Sling Links .....	160-164, 228, 243-246
Mooring Sockets.....	41	Sling Saver —	
Nuts —		Link Plate.....	101
Eye.....	172	Spool.....	101
Lock .....	171	Web Connector .....	103
Open Wire Rope Sockets .....	42, 47	Web Sling Hook.....	102
Pad Eyes .....	171	Web Sling Shackle .....	99-100
Pear Shape Missing Link .....	254	Web Sling System.....	106-107
Plate Clamps .....	410-418, 428	Web to Chain Connector .....	103
Product Warnings —		Web to Web Connector .....	104
Bundle Clips.....	213-214	Sockets .....	36-43
Chain Slings.....	266-268	Spectrum Chain.....	227, 242, 249-252
Crosby/Bullard Hooks.....	146-147	Spelter Sockets .....	40-43
Crosby Clips .....	56	Super Terminator .....	38-39
Crosby Eliminator.....	269-270	Swage Sockets.....	47-48
Crosby Fist Grip Clips .....	57	Swivels —	
Crosby PL Hook Latch Kit.....	151-152	Angular Contact Bearing Swivel .....	138-140
Crosby S-4320 Latch Kit .....	141	Forged Swivel.....	135
Crosby SS-4055 Latch Kit.....	150	Tapered Roller/Thrust Bearing.....	136-137
Crosby S-4338 Latch Kit.....	265	Swivel Hoist Rings.....	177-185
Forged Eye Bolts.....	200-201	Synthetic Sling Saver Shackle.....	99-100
Hoist Hooks .....	142-145	Terminator.....	36
Hydraulic Swaging Machine.....	65-72	Thimbles .....	158-159
Load Binders.....	271	Theatrical Shackles.....	89
Pivot Hoist Rings .....	202-203	Transport Chain .....	252
ROV Hook.....	153-154	Turnbuckles .....	189-198
Sidepull Hoist Rings.....	206-207	Twin Clevis Link .....	255
Split Nut .....	144-145	Vitalife Wire Rope Lubricant.....	199
Swageable Hooks .....	61-62	Wedge Sockets .....	36-37
Swivel Hoist Rings .....	210-212	Weldless Links and Rings .....	165-166
SHUR-LOC® Hooks.....	272-273	Weld-on Hooks.....	120
Tackle Blocks.....	381-388	Weld-on Pivot Links .....	187
Tailchain.....	274-275	Wire Rope Clips .....	34-35
Trench Plate Hoist Ring.....	204-205	Wire Rope Lubricant.....	199
Tubing Grab .....	389-390	Wire Rope Terminations .....	31-54
WIRELOCK®.....	63-64	Wirelock® Resin.....	54
Wedge Sockets .....	58-60		
Weld-on Hooks.....	148-149	<b>LEBUS</b>	
Weld-on Links.....	208-209	Load Binders .....	258-261
Proof Coil Chain .....	250	Load Binder Application Instructions .....	271
Red-U-Bolt (Crosby Clip) .....	34	Snatch Blocks .....	361-369
Regular Forged Swivels .....	135	Winchline Tail Chain .....	274
Replacement Links .....	254		
Rings .....	165		



## MCKISSICK® BLOCKS & SHEAVES

Blocks for Every Purpose —	
Bridge Crane Blocks .....	350-353, 484
Construction Blocks .....	338-348
Crane and Hook Blocks .....	310-335
Drilling.....	375-376
Hoist.....	310-335
Hay Fork Pulley Blocks .....	370
Oilfield .....	366, 371, 377
Scrap Handling Blocks .....	335
Snatch Blocks .....	361-366
Tilt-Up Wall Blocks .....	336-337
Toggle (Tail Board) Blocks .....	361-366
Tower .....	371
Tubing Blocks .....	372
<i>(For additional blocks see Western Section.)</i>	
Block Warning, Use and Maintenance .....	381-388
Fairleaders.....	406
General Block Information.....	381-388
How to Determine Overhauling Weights.....	387
How Sheave Size Affects Wire Rope Strength .....	386
How to Figure Line Parts .....	387-388
How to Order McKissick Blocks and Sheaves .....	308
Loads on Blocks .....	384-385
Reeving of Tackle blocks .....	385
Overhaul Balls .....	354-359
Pull Test Capabilities .....	391
Rigging Information .....	381-388
Sheaves —	
AISE.....	302
API Standards.....	285
Bearings .....	279, 286
Bronze Bushed .....	293-297
Closed Die Forged Sheaves .....	284
Common Bore .....	291-292
Deck Mounted Lead .....	406
Domed Sheaves .....	283
Ductile Iron Sheaves .....	284
Fabricated Sheaves.....	283
Finished Bore .....	288-290
Groove Profiles .....	279, 285
Metric Sheaves.....	303
Oilfield Sheaves.....	300-301
Ordering Information .....	287
Roll Forged Sheaves.....	282
Roller Bearing .....	297-298
Tapered Bearing .....	299
Western.....	304
Special Blocks .....	370
Split Overhaul Balls .....	358
Trawling Blocks .....	401
Try Net Blocks .....	401
Wedge Socket.....	36-39

## NATIONAL SWAGE FITTINGS

Duplex Non-Tapered Sleeve .....	50
Hydraulic Swaging Machine .....	53
Standard Steel Swaging Sleeves .....	44-46
Swage Button .....	49
Swage Sockets.....	47-48

## WESTERN BLOCKS & SHEAVES

Blocks for Manila Rope —	
Fittings for .....	408
Steel Shell —	
Gin Pole Blocks .....	399
Snatch Blocks .....	398
Standard Steel Blocks .....	397
Synthetic Fiber Rope Blocks .....	397
Wood Shell —	
Regular Mortise Blocks .....	396
Painters Blocks .....	399
Snatch Blocks .....	398
Blocks for Wire Rope —	
Fittings for .....	408
Steel Shells —	
Cargo Hoisting Blocks.....	402
Fittings for .....	403
Regular Diamond Pattern Blocks .....	400
Regular Oval Pattern Blocks .....	400
Marine Blocks —	
Cargo Hoisting .....	402-403
Fittings for .....	403
Fairleaders.....	406
Flag Blocks .....	405
Hinged Lead Blocks .....	405
Horizontal Lead Blocks .....	404
Lead Blocks .....	404-405
Miscellaneous —	
Adjuster Fitting for Heel and Lead Block .....	403
Block Maintenance.....	381-388
Fittings for Western Cargo Blocks .....	403
Fittings for Manila or Wire Rope Blocks.....	408
Ordering Instructions .....	394
Training Information .....	380
Pressure Lube Fittings —	
Snatch Blocks .....	395
Oval Pattern Blocks .....	400
Trawl Blocks .....	401
Trynet Blocks .....	401
Vertical Lead Blocks .....	404
Lead Blocks .....	404 - 405
Sheaves —	
Iron for Manila Rope —	
For Regular Mortise Blocks .....	304
For Snatch Blocks .....	304
For Wide Mortise Blocks .....	304
Iron for Wire Rope —	
For Snatch Blocks .....	304
Steel Sheaves .....	304
For Wire Rope Snatch Blocks .....	304
For Manila Rope Snatch Blocks .....	304
Ordering Instructions .....	287

## CROSBY

AS 1-17	138-140
AS-15	358
Bullard	124-129, 256, 264
C186, C-187, C-188	262
Crosby Clampco	429-435
Crosby Easy-Loc	83, 85-87
Crosby IP	409-428
Crosby Kuplex	447-470
Crosby Trawlex	437-445
PL, PN -N/O	122
S-3 (Proof Coil)	250
S-4 (High Test)	251
S-7 (Transport)	252
S-8 (Alloy)	242
S-10 (Alloy)	227
S-1 to S-6	136-137
SL-150	187
Sling I.D. tag	238
Vitalife	199
100	183
125	174-176, 180-181, 185
209	77, 78, 89-91
210	77
213	76
215	76
223	189
225	190
226	191
227	191
228	193
237	104
238	104
247	255
249	255
251	198
252 - 253	100
255	101
256	101
257	171
264	171
265	187
275	168
276	170
277	168
279	169
280	98
281	99
282	103
287	103
291	167
293	170
313	120
314 - 315	246
318	262
319	51, 112-113, 263
320	102, 114-115, 130
322	116
323	256
324	257
330	256
331	257
334	254
335	254
336	253
340	165
341	166
342	160, 164, 243
344	162, 245
345	161, 164, 244
347	163, 246
350	132
377	133
378	134
400	172
401 - 403	135
405	172
408	159

411 - 412	159
414	158
416	42
416-7 (WIRELOCK®)	54
417	43
421	36
422	37
423	39
427	40
429	35
450	34
460 - 461	173
500	182
501	47
502	48
517	41
562	131
643	165
700	369
720	369
1000	177-179
1200	184
1210	133
1311N	237
1316	118, 235
1317	235
1318	118
1325	237
1326	119, 236
1327	230
1328	234
1329	232
1337	227
1338	233
1339	231
1343	229
1346	229
1348	228
1355	238
1358	233
1359	232
1360	226
1361	225
1362	225
1370	228
2130	79, 81, 88
2131	407
2140	82-83, 88
2150	80
2160	84-85
2169	78
2170	87
2510	197
3315	133
3316	134
3319	120
3322B	117
4037	194-196
4055	123
4060 - 4061	198
4061	198
4088	123, 248
4209	90
4104	226
4320	121, 248
4338	248
13326	119, 236

## LEBUS

A-1W	260
L-130	261
L-140	259
L-150	258, 261
L-160	367
L-170	368
L-180	262
R-10	260
R-7QL	259

## MCKISSICK

Drilling Blocks	375-326
Easy Reeve Crane Blocks	325-333
Scrap Handling Block	335
RJ	375
RP	376
HF-1 TO HF-14	370
SHB	358
Sheaves	277-304
TGRB	378
TU480 - 484	336-337
UB500	354-357
UB550	359
70 Series	372
80 Series	372
171	370
241 - 243	374
380 Series	310-330
381 Series	335
401	366
402	365
404	361
406	362
407	363
408, 409	364
416, 417	365
418, 419	361
420, 421	362
422	37, 354, 356
430, 431	363
432, 433	364
434, 435	366
443	370
452 - 454	401
457	406
458 - 459	377
461	406
463	406
475	373
480 Series	336-337
491	371
680 Series	338-348
731 - 734	374
741 - 745	374
750 Series	350-353
790 Series	331-333

## WESTERN

21 - 23	396
130	399
135	399
261 - 263	397
301 - 303	396
350	399
385	398
390	398
411 - 413	397
566	402-403
600 - 601	404
602 - 603	405
641 - 642	400
661 - 662	400
681 - 683	407
1101 - 1103	304
1141 - 1143	304
1192	304
1210	135
1293	304
1298	304
Sheaves	304
2131	407

## NATIONAL

Hydraulic Swaging Machine	53
409	49
501	47
502	48
505	44-45
506	50



# Decimal and Metric Conversion Table

## Decimal and Metric Conversion Table

Fractional Equivalent (in.)	Decimal Equivalent (in.)	Metric Equivalent (mm)
1/64	.0156	.397
1/32	.0312	.794
3/64	.0469	1.191
1/16	.0625	1.588
5/64	.0781	1.984
3/32	.0938	2.381
7/64	.1094	2.778
1/8	.1250	3.175
9/64	.1406	3.572
5/32	.1562	3.969
11/64	.1719	4.366
3/16	.1875	4.762
13/64	.2031	5.159
7/32	.2188	5.556
15/64	.2344	5.953
1/4	.2500	6.350
17/64	.2656	6.747
9/32	.2812	7.144
19/64	.2969	7.541
5/16	.3125	7.938
21/64	.3281	8.334
11/32	.3438	8.731
23/64	.3594	9.128
3/8	.3750	9.525
25/64	.3906	9.922
13/32	.4062	10.319
27/64	.4219	10.716
7/16	.4375	11.112
29/64	.4531	11.509
15/32	.4688	11.906
31/64	.4844	12.303
1/2	.5000	12.700

Fractional Equivalent (in.)	Decimal Equivalent (in.)	Metric Equivalent (mm)
33/64	.5156	13.097
17/32	.5312	13.494
35/64	.5469	13.891
9/16	.5625	14.288
37/64	.5781	14.684
19/32	.5938	15.081
39/64	.6094	15.478
5/8	.6250	15.875
41/64	.6406	16.272
21/32	.6562	16.669
43/64	.6719	17.065
11/16	.6875	17.462
45/64	.7031	17.859
23/32	.7188	18.256
47/64	.7344	18.653
3/4	.7500	19.050
49/64	.7656	19.447
25/32	.7812	19.844
51/64	.7969	20.241
13/16	.8125	20.638
53/64	.8281	21.034
27/32	.8438	21.431
55/64	.8594	21.828
7/8	.8750	22.225
57/64	.8906	22.622
29/32	.9062	23.019
59/64	.9219	23.416
15/16	.9375	23.812
61/64	.9531	24.209
31/32	.9688	24.606
63/64	.9844	25.003
1	1.0000	25.400

### Mass Conversions

- To convert from U.S. tons to metric tons multiply by .907185
- To convert from metric tons to U.S. tons multiply by 1.10231
- To convert from metric tons to pounds multiply by 2204.62
- To convert from metric tons to kilograms multiply by 1000
- To convert from pounds to kilograms multiply by .453592
- To convert from kilograms to pounds multiply by 2.20462

### Temperature Conversion

To convert from degree fahrenheit to degree celsius use

$$T_c = 5/9 (T_f - 32)$$

To convert from degree celsius to degree fahrenheit use

$$T_f = 9/5 (T_c) + 32$$

## Reliability You Can Depend On, Crosby "QT" Fittings.

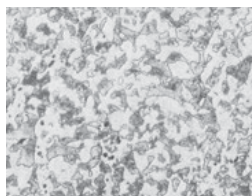

AS FORGED

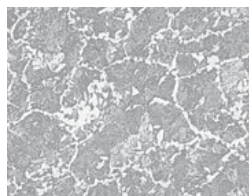

NORMALIZED

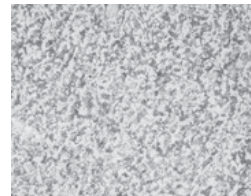

QUENCHED & TEMPERED

Unretouched Photomicrographs (100x) of fitting

